

LK3-B448E Mark II / BA-16

INSTRUCTION MANUAL



Please read this manual before using the machine.
Please keep this manual within easy reach for quick reference.

ELECTRONIC LOCKSTITCH BUTTON SEWER WITH BUTTON FEEDER

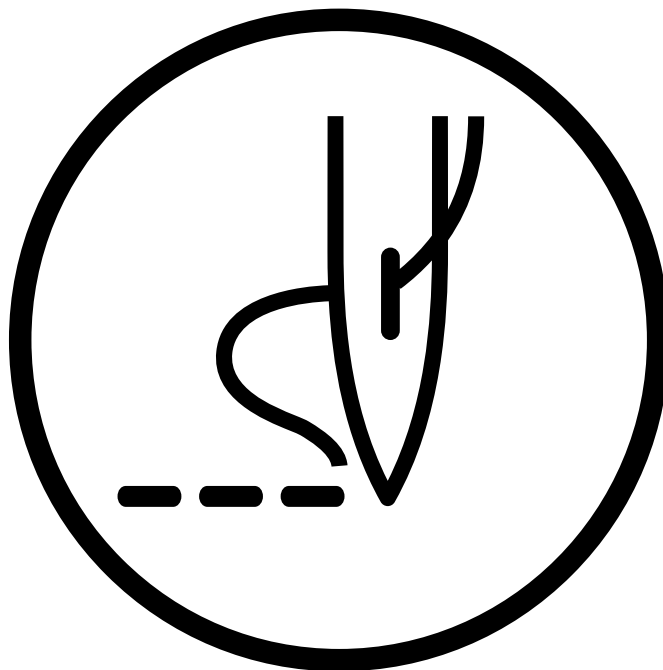

brother[®]

Thank you very much for buying a BROTHER sewing machine. Before using your new machine, please read the safety instructions below and the explanations given in the instruction manual.



With industrial sewing machines, it is normal to carry out work while positioned directly in front of moving parts such as the needle and thread take-up lever, and consequently there is always a danger of injury that can be caused by these parts. Follow the instructions from training personnel and instructors regarding safe and correct operation before operating the machine so that you will know how to use the machine correctly.

SAFETY INSTRUCTIONS

1 Safety indications and their meanings

This instruction manual and the indications and symbols that are used on the machine itself are provided in order to ensure safe operation of this machine and to prevent accidents and injury to yourself or other people. The meanings of these indications and symbols are given below.

Indications

 DANGER	The instructions which follow this term indicate situations where failure to follow the instructions will almost certainly result in death or severe injury.
 CAUTION	The instructions which follow this term indicate situations where failure to follow the instructions could cause injury when using the machine or physical damage to equipment and surroundings.

Symbols



..... This symbol (△) indicates something that you should be careful of. The picture inside the triangle indicates the nature of the caution that must be taken.
(For example, the symbol at left means “beware of injury”.)



..... This symbol (⊘) indicates something that you must not do.



..... This symbol (●) indicates something that you must do. The picture inside the circle indicates the nature of the thing that must be done.
(For example, the symbol at left means “you must make the ground connection”.)

DANGER



Wait at least 5 minutes after turning off the power switch and disconnecting the power cord from the wall outlet before opening the face plate of the control box. Touching areas where high voltages are present can result in severe injury.

CAUTION

Environmental requirements



Use the sewing machine in an area which is free from sources of strong electrical noise such as high-frequency welders.

Sources of strong electrical noise may cause problems with correct operation.



Any fluctuations in the power supply voltage should be within $\pm 10\%$ of the rated voltage for the machine. Voltage fluctuations which are greater than this may cause problems with correct operation.



The power supply capacity should be greater than the requirements for the sewing machine's electrical consumption.

Insufficient power supply capacity may cause problems with correct operation.



The ambient temperature should be within the range of 5°C to 35°C during use.

Temperatures which are lower or higher than this may cause problems with correct operation.



The relative humidity should be within the range of 45% to 85% during use, and no dew formation should occur in any devices.

Excessively dry or humid environments and dew formation may cause problems with correct operation.



Avoid exposure to direct sunlight during use.

Exposure to direct sunlight may cause problems with correct operation.



In the event of an electrical storm, turn off the power and disconnect the power cord from the wall outlet.

Lightning may cause problems with correct operation.

Installation



Machine installation should only be carried out by a qualified technician.



Contact your Brother dealer or a qualified electrician for any electrical work that may need to be done.



The sewing machine weighs more than 47 kg. The installation should be carried out by two or more people.



Do not connect the power cord until installation is complete, otherwise the machine may operate if the foot switch is pressed by mistake, which could result in injury.



Hold the machine head with both hands when tilting it back or returning it to its original position.

Furthermore, after tilting back the machine head, do not push the face plate side or the pulley side from above, as this could cause the machine head to topple over, which may result in personal injury or damage to the machine.



Be sure to connect the ground. If the ground connection is not secure, you run a high risk of receiving a serious electric shock, and problems with correct operation may also occur.



All cords should be secured at least 25 mm away from any moving parts. Furthermore, do not excessively bend the cords or secure them too firmly with staples, otherwise there is the danger that fire or electric shocks could occur.



Install the belt covers to the machine head and motor.



If using a work table which has casters, the casters should be secured in such a way so that they cannot move.













Be sure to wear protective goggles and gloves when handling the lubricating oil and grease, so that they do not get into your eyes or onto your skin, otherwise inflammation can result.

Furthermore, do not drink the oil or eat the grease under any circumstances, as they can cause vomiting and diarrhoea.



Keep the oil out of the reach of children.

CAUTION









Sewing

- | | |
|---|--|
|  This sewing machine should only be used by operators who have received the necessary training in safe use beforehand. |  If using a work table which has casters, the casters should be secured in such a way so that they cannot move. |
|  The sewing machine should not be used for any applications other than sewing. |  Attach all safety devices before using the sewing machine. If the machine is used without these devices attached, injury may result. |
|  Be sure to wear protective goggles when using the machine.
If goggles are not worn, there is the danger that if a needle breaks, parts of the broken needle may enter your eyes and injury may result. |  Do not touch any of the moving parts or press any objects against the machine while sewing, as this may result in personal injury or damage to the machine. |
|  Set the needle to the needle up stop position before turning on the power.
If this is not done, the wiper may strike the needle, which might cause the needle to break. |  If an error occurs in machine, or if abnormal noises or smells are noticed, immediately turn off the power switch. Then contact your nearest Brother dealer or a qualified technician. |
|  Turn off the power switch at the following times, otherwise the machine may operate if the foot switch is pressed by mistake, which could result in injury. <ul style="list-style-type: none">• When threading the needle• When replacing the needle and bobbin• When not using the machine and when leaving the machine unattended |  If the machine develops a problem, contact your nearest Brother dealer or a qualified technician. |

Cleaning

- | | |
|---|---|
|  Set the needle to the needle up stop position before turning on the power.
If this is not done, the wiper may strike the needle, which might cause the needle to break. |  Be sure to wear protective goggles and gloves when handling the lubricating oil and grease, so that they do not get into your eyes or onto your skin, otherwise inflammation can result. |
|  Turn off the power switch before carrying out cleaning, otherwise the machine may operate if the foot switch is pressed by mistake, which could result in injury. | Furthermore, do not drink the oil or eat the grease under any circumstances, as they can cause vomiting and diarrhoea.
Keep the oil out of the reach of children. |

Maintenance and inspection

- | | |
|---|--|
|  Maintenance and inspection of the sewing machine should only be carried out by a qualified technician. |  Hold the machine head with both hands when tilting it back or returning it to its original position. Furthermore, after tilting back the machine head, do not push the face plate side or the pulley side from above, as this could cause the machine head to topple over, which may result in personal injury or damage to the machine. |
|  Ask your Brother dealer or a qualified electrician to carry out any maintenance and inspection of the electrical system. |  Use only the proper replacement parts as specified by Brother. |
|  Set the needle to the needle up stop position before turning on the power.
If this is not done, the wiper may strike the needle, which might cause the needle to break. |  If any safety devices have been removed, be absolutely sure to re-install them to their original positions and check that they operate correctly before using the machine. |
|  Turn off the power switch and disconnect the power cord from the wall outlet at the following times, otherwise the machine may operate if the foot switch is pressed by mistake, which could result in injury. <ul style="list-style-type: none">• When carrying out inspection, adjustment and maintenance• When replacing consumable parts such as the rotary hook |  Any problems in machine operation which result from unauthorized modifications to the machine will not be covered by the warranty. |
|  If the power switch needs to be left on when carrying out some adjustment, be extremely careful to observe all safety precautions. | |

3 Warning labels

★ The following warning labels appear on the sewing machine.

Please follow the instructions on the labels at all times when using the machine. If the labels have been removed or are difficult to read, please contact your nearest Brother dealer.

1

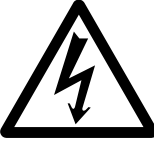
	⚠ DANGER Hazardous voltage will cause injury. Turn off main switch and wait 5 minutes before opening this cover.	⚠ GEFAHR Hochspannung verletzungsgefahr! Bitte schalten sie den hauptschalter aus und warten sie 5 minuten, bevor sie diese abdeckung ffnen.	⚠ DANGER Un voltage non adapt provoqe des blessures. Eteindre l'interrupteur et attendre 5 minutes avantd' ouvrir le capot	⚠ PELIGRO Un voltaje inadecuado puede provocar las heridas. Apagar el interruptor principal y esperar 5 minutos antes de abrir esta cubierta.
	⚠ DANGER			

2

⚠ CAUTION	
	Moving parts may cause injury. Operate with safety devices. Turn off main switch before threading, changing bobbin and needle, cleaning etc.

3



Be sure to connect the ground.
If the ground connection is not secure, you run the risk of receiving a serious electric shock.

4

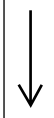

Direction of operation

Safety devices:

- ① Belt cover,
- ② Thread take-up cover,
- ③ Eye guard,
- ④ Motor cover,
- ⑤ Thread take-up solenoid cover, etc.

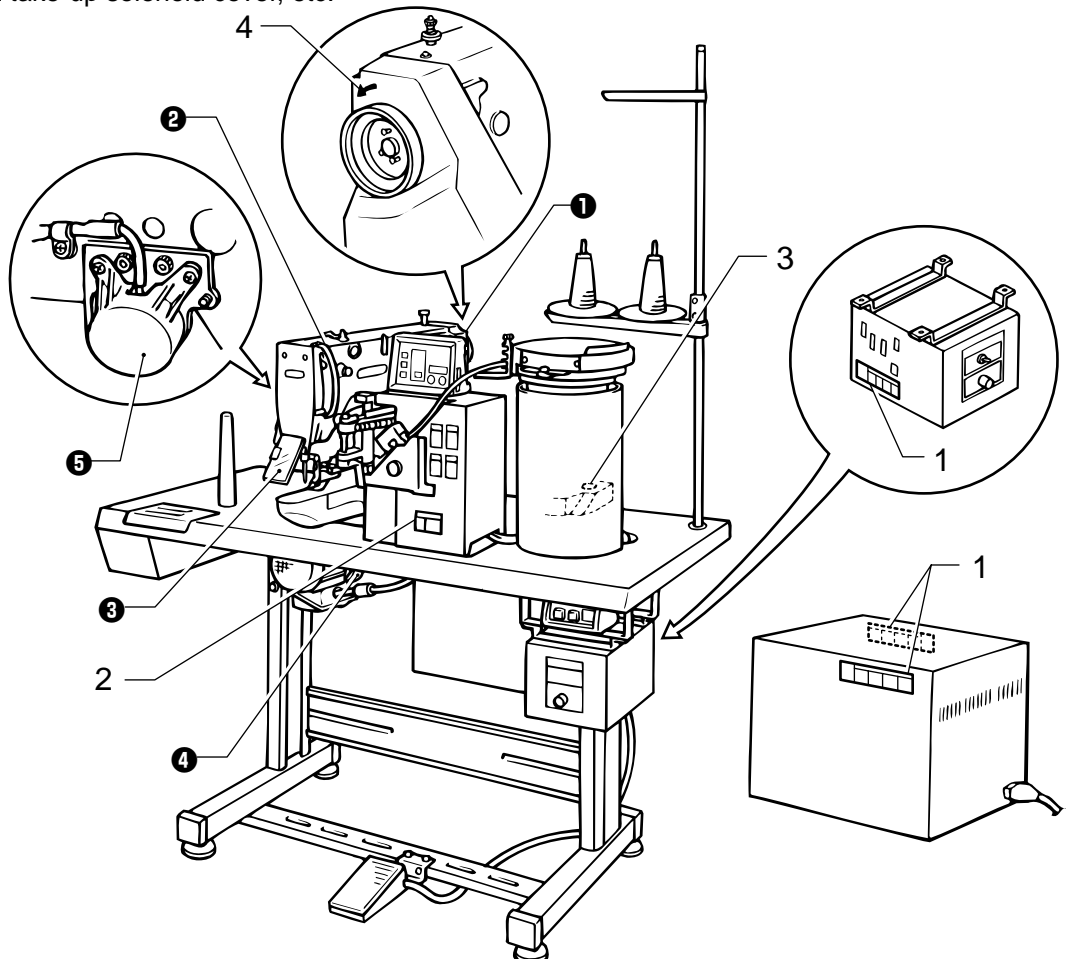

CONTENTS

1. Name of each part	1
2. Specifications	2
2-1. Specifications	2
2-2. Program list	3
2-3. Optional parts	6
3. Installation	7
3-1. Power table	7
3-2. Installing the motor	8
3-3. Installing the motor pulley	8
3-4. Installing the control box	9
3-5. Installing the oil pan	10
3-6. Installing the cushions	10
3-7. Installing the machine head	11
3-8. Installing the head rest	11
3-9. Installing the liquid cooling tank, optional	12
3-10. Installing the vibrating bowl	12
3-11. Installing the control box (for vibrating bowl)	12
3-12. Installing the button feeder	13
3-13. Installing the shooter	13
3-14. Connecting the cords	14
3-15. Installing the button feeder cover	16
3-16. Installing the operation panel	17
3-17. Connecting the ground wire	17
3-18. Installing the V-belt	18
3-19. Installing the belt cover	19
3-20. Installing the foot switch	19
3-21. Installing the motor cover	20
3-22. Installing the spool stand	20
3-23. Installing the eye guard	20
3-24. Adjustment by the accessory spring	21
4. Lubrication	22
4-1. Lubrication points	22
4-2. Applying grease	23
4-3. Draining the oil	23
5. Operation	24
5-1. Name and function of each operation panel item	24
5-2. Operating procedure	26
5-2-1 . Setting the program number	26
5-2-2 . Setting the X-scale and Y-scale	26
5-2-3 . Setting the sewing speed	26
5-3. Operating the button feeder	27
5-4. Operating the vibrating bowl	27
6. Checking the sewing pattern	28
7. Correct use	29
7-1. Selecting the needle and thread	29
7-2. Installing the needle	29
7-3. Threading the upper thread	29
7-4. Winding the lower thread	30
7-5. Replacing the bobbin case and threading the thread	31
7-6. Thread tension reference guide	31
7-6-1. Lower thread tension	31
7-6-2. Upper thread tension	31
7-6-3. Thread take-up spring height	32
7-6-4. Thread take-up spring tension	32
7-6-5. Adjusting arm thread guide R	32
7-6-6. Thread take-up amount	32

8. Sewing	33
9. Maintenance and inspection	34
9-1. Cleaning the rotary hook	34
9-2. Cleaning the control box air inlet port	34
9-3. Cleaning the eye guard	35
9-4. Checking the needle	35
10. Adjustments	36
10-1. Adjusting the needle bar height	37
10-2. Adjusting the needle bar lift amount	37
10-3. Adjusting the driver needle guard	38
10-4. Adjusting the needle clearance	38
10-5. Adjusting the shuttle race thread guide	38
10-6. Adjusting the thread take-up amount	39
10-7. Adjusting the movable knife	39
10-7-1. Replacing the movable knife and fixed knife	40
10-7-2. Adjustment the engagement of the movable knife and fixed knife	41
10-8. Adjusting the button clamp lift amount	41
10-9. Adjusting the holding pressure	42
10-10. Adjusting the position of the button holder	42
10-11. Adjusting the button clamp height	43
10-12. Adjusting the needle up stop position	44
10-13. Adjusting the thread wiper	44
10-14. Adjusting the vibrating bowl	45
10-15. Adjustment for excess buttons in the button shooter	46
10-16. Button replacement	47
10-16-1. Adjustment when the button diameter is changed	47
10-16-2. Adjustment when the button thickness changed	48
10-16-3. If button hole arrangements differ	48
10-16-4. Adjusting the button carrier plate	48
10-16-5. Adjusting the feeder position adjustment	49
10-16-6. Adjusting the needle location	50
10-17. Replacement the V-belt	51
10-18. Checking the input sensor and DIP switch input	53
10-19. Checking the input voltage	54
10-20. Moving stitch patterns	55
11. Using the counters	56
11-1. Using the bobbin thread counter	56
11-2. Using the production counter	56
12. Using user programs	57
13. Using the cycle sewing function	59
14. Changing functions using the DIP switches	61
14-1. Operation panel DIP switches	61
14-2. Setting the presser mode	61
14-3. DIP switches inside the control box	62
15. Changing special functions using the memory switches	63
15-1. Clearing all memory settings	63
16. Table of error codes	65
17. Adjustment guide refer to this guide	
when different button are used	67
18. Troubleshooting	68

1. Name of each part

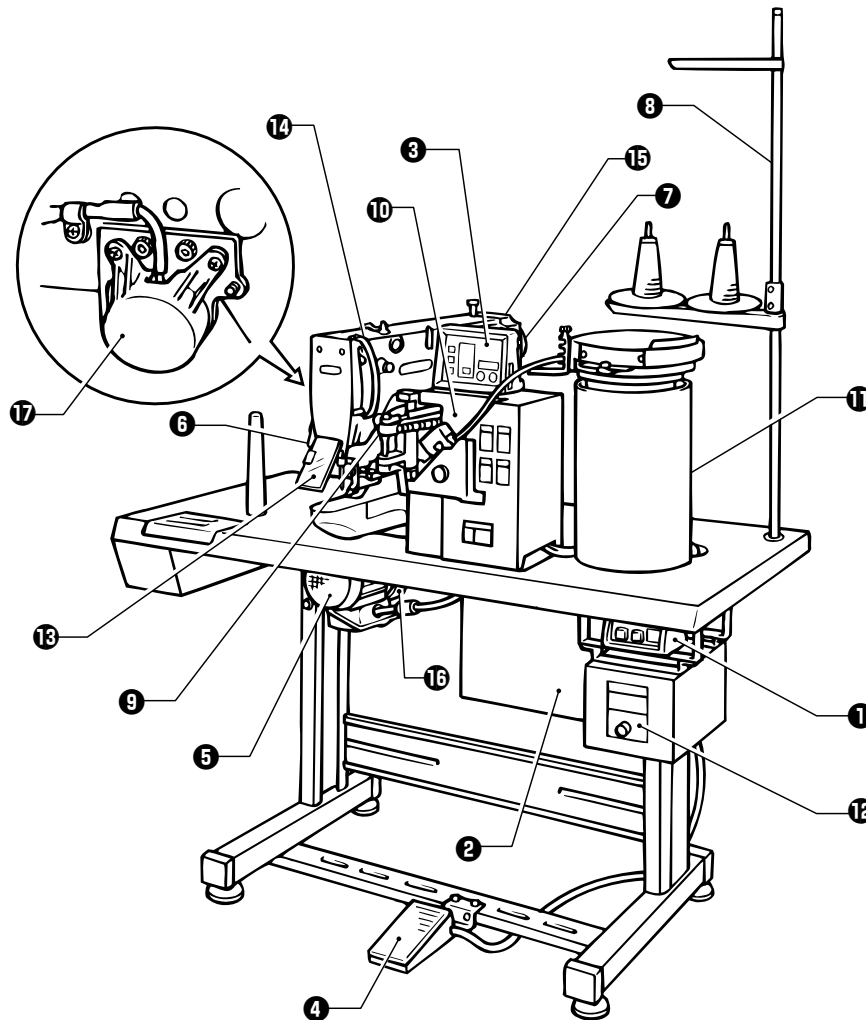

- | | | | |
|---------------------------|-------------------------|-------------------|---------------|
| ❶ Power switch | ❷ Control box | ❸ Operation panel | ❹ Foot switch |
| ❺ Motor | ❻ Tension release lever | ❼ Pulley | ❽ Spool stand |
| ❾ Thread take-up lever | ❿ Button feeder | ⓫ Vibrating bowl | ⓬ Control box |
| Ⓜ Eye guard | Ⓨ Thread take-up cover | Ⓩ Belt cover | ⓐ Motor cover |
| ⓑ Thread take-up solenoid | | | |

2. Specifications

2. Specifications







2-1. Specifications

Stitch formation	Single needle lock stitch
Maximum sewing speed	2,500 rpm
Maximum pattern size	0 - 6.4 X 0 - 6.4 mm
Needle	TQ X 1#12
Dimensions of buttons that can be sewn	Outer diameter of button 9 - 22 mm Space between the button holes 2.5 - 6.4 mm
Button clamp height	10 mm (standard)
Thread knot	Knot tied by needle
Feed mechanism	R-θ intermittent feed mechanism (pulse-motor driven mechanism)
Stitch length	0.1 - 6.4 mm
Number of stitches	Variable (13, 15, 17, 19, 20, 22, 23, 24, 26, 27, 28, 30, 32, 34, 38 stitches pre-set)
Maximum stitch number	20,000 stitches (including 10,000 stitches which can be added)
Work clamp lifter	Solenoid type
Rotary hook	Shuttle hook
Wiper device	Standard equipment. (Solenoid-type thread wiper (Option))
Thread trimmer device	Standard equipment
Thread take-up device	Standard equipment
Data storage method	P-ROM (Any sewing pattern can be added using BAS-PC/300.)
Number of user programs	16
Number of cycle programs	4
Number of stored data	49 sewing patterns are set already. (Up to 100 patterns can be added. Total number of stitches of stored data which can be added is within 10,000.)
Motor	Three-phase 400W induction motor
Weights	Machine head: 47kg, Operation panel: 0.6kg, Control box: 9 - 19kg (depending on destination)
Power source	Single-phase 220 - 230V 3-phase 220, 380, 400, 415V Maximum electric power consumption; 600VA

2-2. Program list

Sewing patterns are limited as shown in the table below.

(Any program is available as long as the needle drops down in the hole of the button.)

Program No.	No. of button holes	Sewing pattern	No. of threads	No. of crossover stitches	No. of stitches	Standard sewing length X	Standard sewing width Y
1	2		6	—	13	3.4mm	0mm
2			8	—	15		
3			10	—	17		
4			12	—	19		
5 *1			16	—	23		
6 *1			20	—	27		
7 *2	2		6	—	13	0mm	3.4mm
23 *2			10	—	17		
8 *2			12	—	19		
9 *2	3		5-5-5	—	22	2.6mm	2.4mm
24 *2			7-7-7	—	28		
25 *2			5-5-5	—	22		
26 *2			7-7-7	—	28		
10 *2	4		6-6	1	20	3.4mm	3.4mm
11 *2			8-8	1	24		
12 *2			8-8	3	26		
13 *2			10-10	1	28		
27 *2			12-12	1	32		
14 *3	4		6-6	0	26		
28 *3			8-8	0	30		
15 *3			10-10	0	34		
29 *3			12-12	0	38		

2. Specifications

Program No.	No. of button holes	Sewing pattern	No. of threads	No. of crossover stitches	No. of stitches	Standard sewing length X	Standard sewing width Y		
16	4		6-5	1	19	3.4mm	3.4mm		
17			8-7	1	23				
30			10-9	1	27				
18 *2			6-6	1	20				
19 *2			8-8	1	24				
31 *2			10-10	1	28				
45 *2			12-12	1	32				
20 *3			6-6	0	26				
32 *3			8-8	0	30				
33 *3			10-10	0	34				
21 *2			6-6	1	20			2.4mm	3.4mm
34 *2			10-10	1	28				
22 *2*3			6-6	0	26				
35 *2*3			10-10	0	34				
46			6-6	1	20			3.4mm	3.4mm
47			8-8	1	24				
48	10-10		1	28					
49	12-12		1	32					

*1 Check that the button hole diameter is 2 mm or greater before using the programs.



*2 Do not use the button lifter spring.

*3 the presser foot lifts up once and the wiper operates, and then the other side is sewn, because there is no crossover thread to be sewn. (Operation will be different if the optional solenoid-type thread wiper is installed. [Refer to page 5].)

• If you want to sew a pattern other than one of the standard 24 patterns, you can create your original pattern using the BAS-PC/300.

Consult with your local Brother Sales Office for details.

2. Specifications

Program No.	No. of button holes	Sewing pattern	No. of threads	No. of crossover stitches	No. of stitches	Standard sewing length X	Standard sewing width Y
36	4		6-6	0	26	3.4mm	3.4mm
37			8-8	0	30		
38			10-10	0	34		
39			12-12	0	38		
40			6-6	0	26		
41			8-8	0	30		
42			10-10	0	34		
43 *			6-6	0	26	2.4mm	3.4mm
44 *			10-10	0	34		

*2 Do not use the button lifter spring.

2. Specifications

2-3. Optional parts

■ Liquid cooling tank

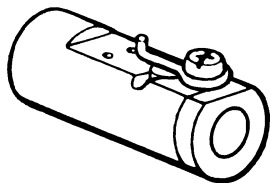

This helps to prevent thread breakages caused by friction when using synthetic threads.

Fill the tank with silicone oil (100 mm²/s).

■ Two-pedal foot switch

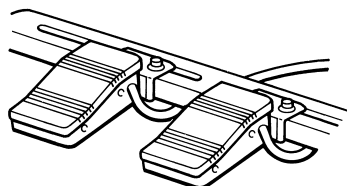

The switch has an independent presser switch (left side) and start switch (right side).

■ Solenoid-type thread wiper

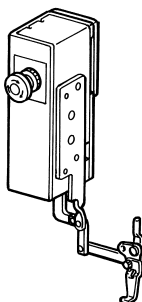

When sewing without crossover threads (program Nos 14, 15, 20 and 22, 28, 29 and 32, 33, 35), do not move the button clamp assembly vertically while sewing is in progress. (Refer to "Changing special functions using the memory switches" on page 59 "memo 14".)

■ Button spacer set

S09661-001

For men's garments

For women's garments

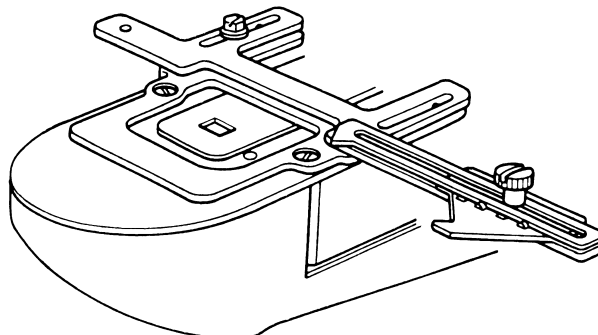
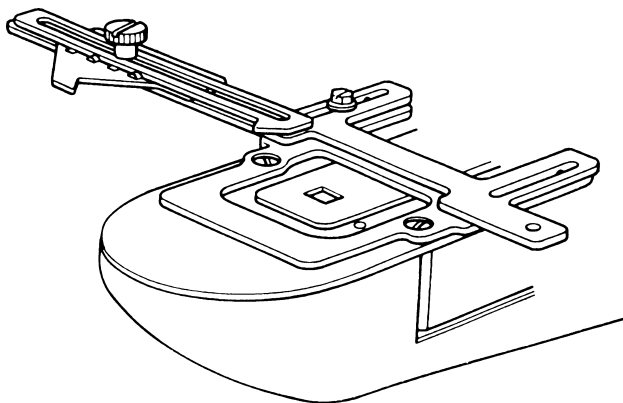

3. Installation

⚠ CAUTION

- ⊘ Machine installation should only be carried out by a qualified technician.
- ⚠ Contact your Brother dealer or a qualified electrician for any electrical work that may need to be done.
- ⚠ The sewing machine head weighs more than 47 kg. The installation should be carried out by two or more people.
- ⊘ Do not connect the power cord until installation is complete, otherwise the machine may operate if the foot switch is depressed by mistake, which could result in injury.
- ⊘ Hold the machine head with both hands when tilting it back or returning it to its original position. Furthermore, after tilting back the machine head, do not push the face plate side or the pulley side from above, as this could cause the machine head to topple over, which may result in personal injury or damage to the machine.
- ⚠ All cords should be secured at least 25 mm away from any moving parts. Furthermore, do not excessively bend the cable or secure it too firmly staples, otherwise there is the danger that fire or electric shocks could occur.
- ⚠ Be sure to connect the ground. If the ground connection is not secure, you run the risk of receiving a serious electric shock.
- ⚠ Install the belt covers to the machine head and motor.
- ⚠ Avoid setting up the sewing machine near sources of strong electrical noise such as high-frequency welding equipment. If this precaution is not taken, incorrect machine operation may result.

3-1. Power table

- Use the power table which has been specially designed for the B448E.

* If using a commercially-available table, process it as shown in the illustration below.

	Model code
Table/legs assembly	127-Z48-00001

NOTE: The thickness of the table should be at least 40 mm, and it should be strong enough to bear the weight and vibration of the sewing machine.

If the distance A between the insides of the legs is less than 740 mm, move the control box installation position closer to the motor (B=247 mm).

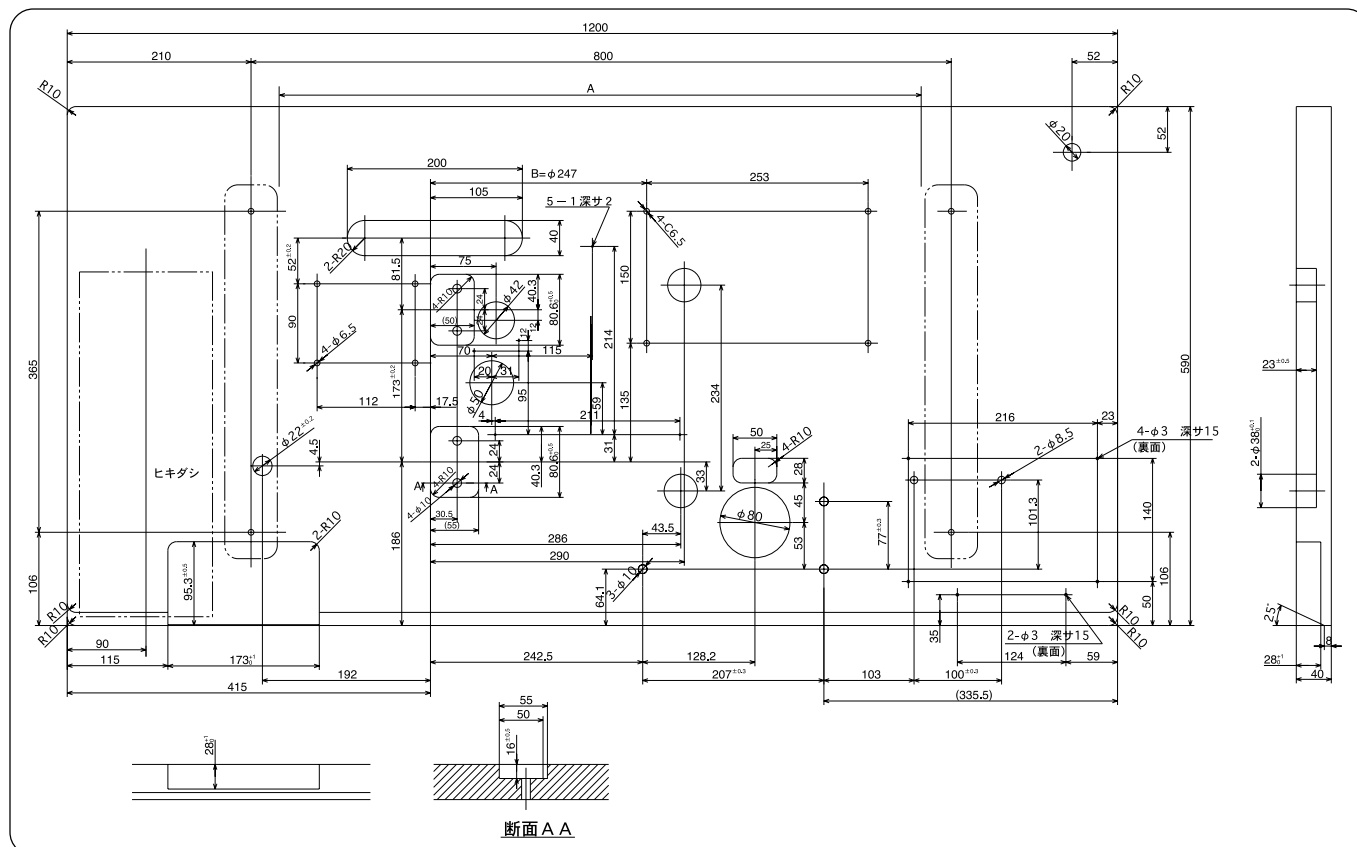

3. Installation

3-2. Installing the motor

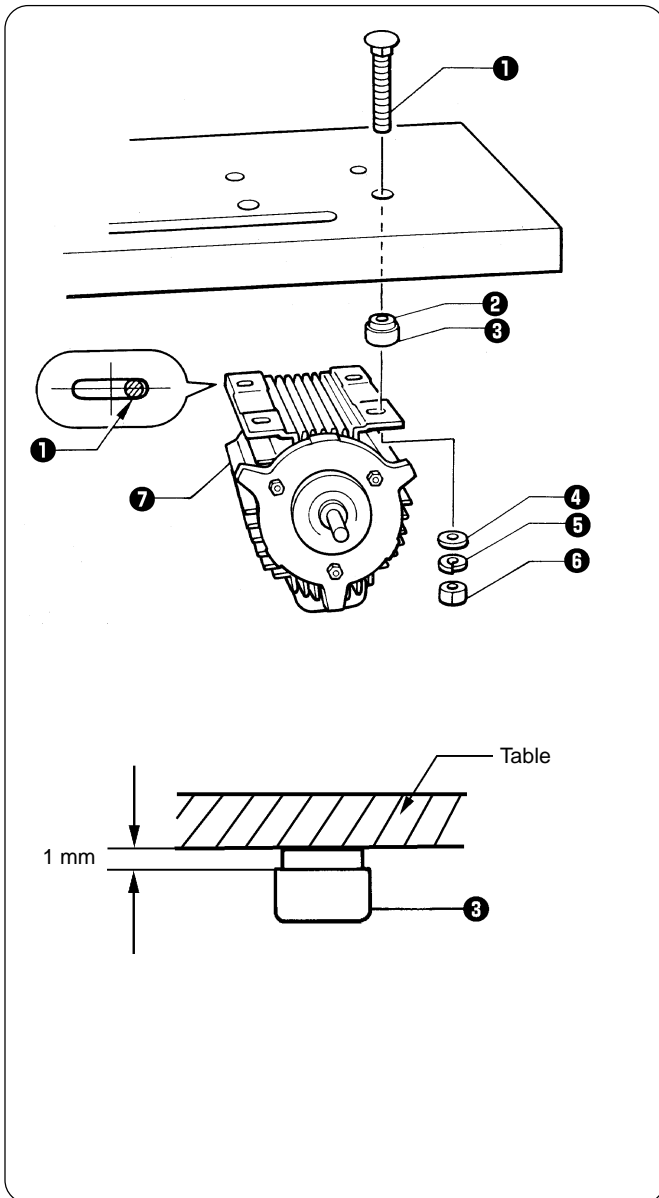

Install the motor **7** to the work table with the four accessory bolts **1**, cushions **2**, cushion collars **3**, flat washers **4**, spring washers **5** and nuts **6**. At that time, fix by setting bolts **1** a little to the right of oval hole on motor.

NOTE:

Tighten the nuts so that the clearance between the table and the cushion collars is approximately 1 mm.

3-3. Installing the motor pulley

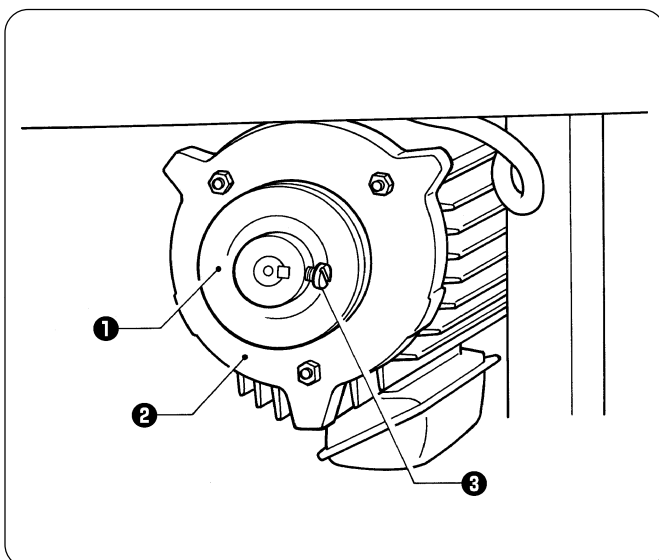

Place the motor pulley **1** onto the shaft of the motor **2** so that the key groove is aligned, and then tighten the set screw **3** so that the center of the V groove in the motor pulley **1** is aligned as closely as possible with the center of the belt hole in the power table.

3-4. Installing the control box

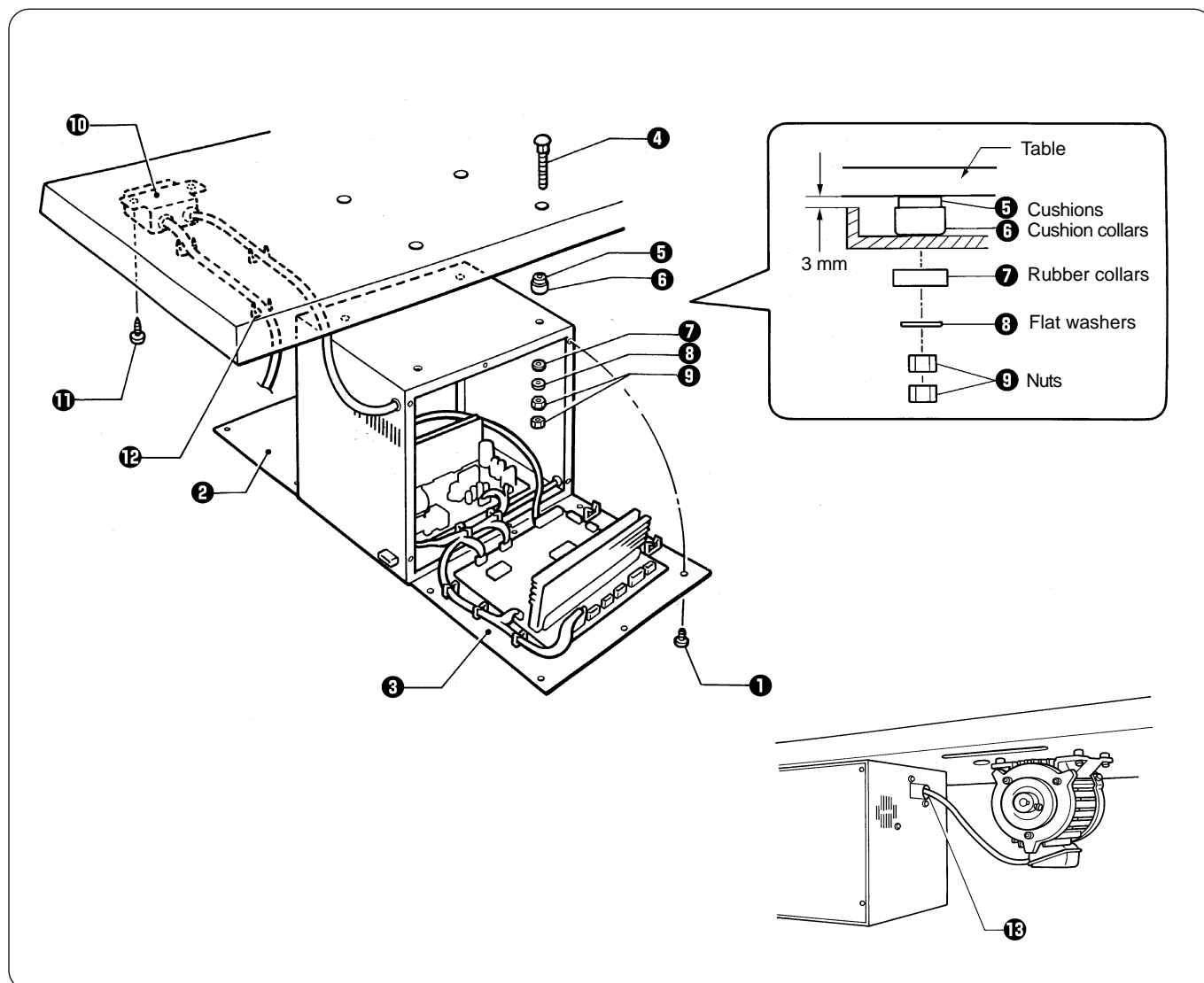

1. Remove the 12 screws **1**, and then open the covers (panel mounting assembly **2** and main P.C. board mounting plate **3**).

NOTE:

When opening the cover, hold it securely so that it does not fall down.

2. Install the control box with the four accessory bolts **4**, cushions **5**, cushion collars **6**, rubber collars **7**, flat washers **8** and nuts **9** as shown in the illustration above. At this time, leave a gap of approximately 3 mm between the work table and the top of the box.

* Use two nuts **9** at each installation location, and make sure that both nuts are tightened.

3. Close the covers (panel mounting assembly **2** and main P.C. board mounting plate **3**), and tighten them with the screws **1**.

* The main P.C. board mounting plate **3** will be opened again during "3-13. Connecting the cords", so provisionally tighten it with the screw **1**.

4. Install the power switch **10** with the two screws **11**.
5. Secure the power switch cord with the three staples **12**.
6. Pass the motor cord through the cord hole **13**.

3. Installation

3-5. Installing the oil pan

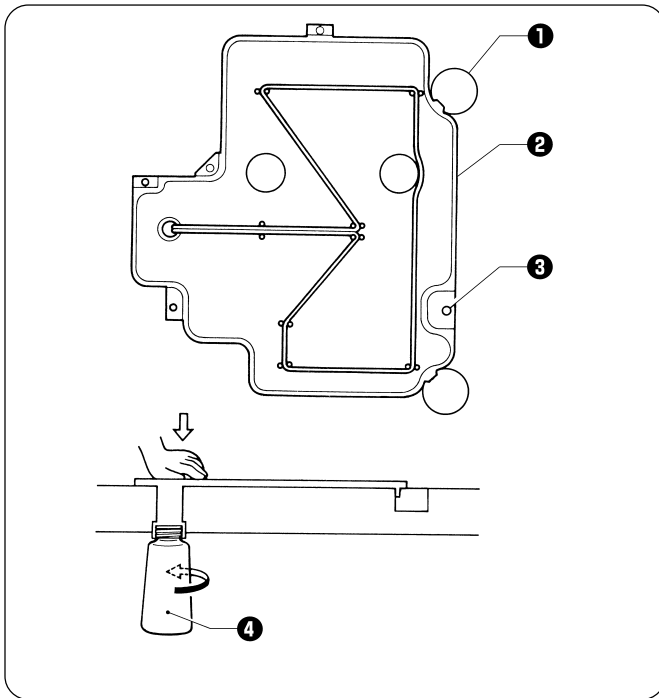

1. Insert the tabs of the oil pan **2** into the holes for the cushions **1**, and then secure it in place with the five nails **3** so that the oil pan **2** is not at an angle.
2. While pushing the oil pan **2** down from above, screw in the oil container **4**.

3-6. Installing the cushions

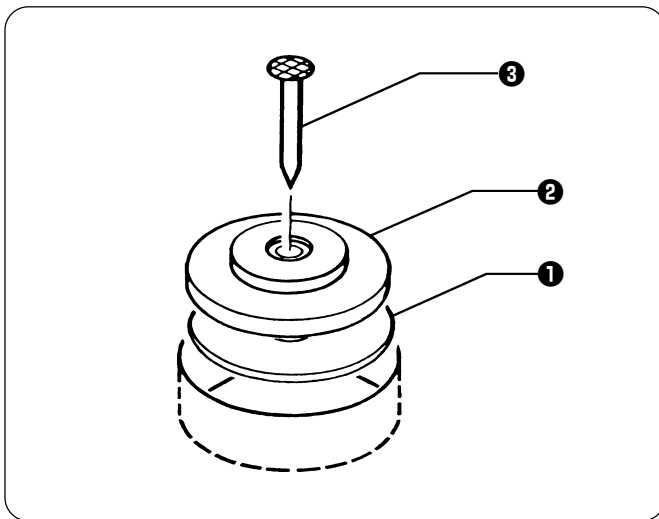

1. Place the washers **1** and cushions **2** into the two holes in the work table.
* Adjust the height of the machine head to the button feeder by the number of the washers **1**.
2. After the height is decided, secure them with the nails **3**.

3-7. Installing the machine head

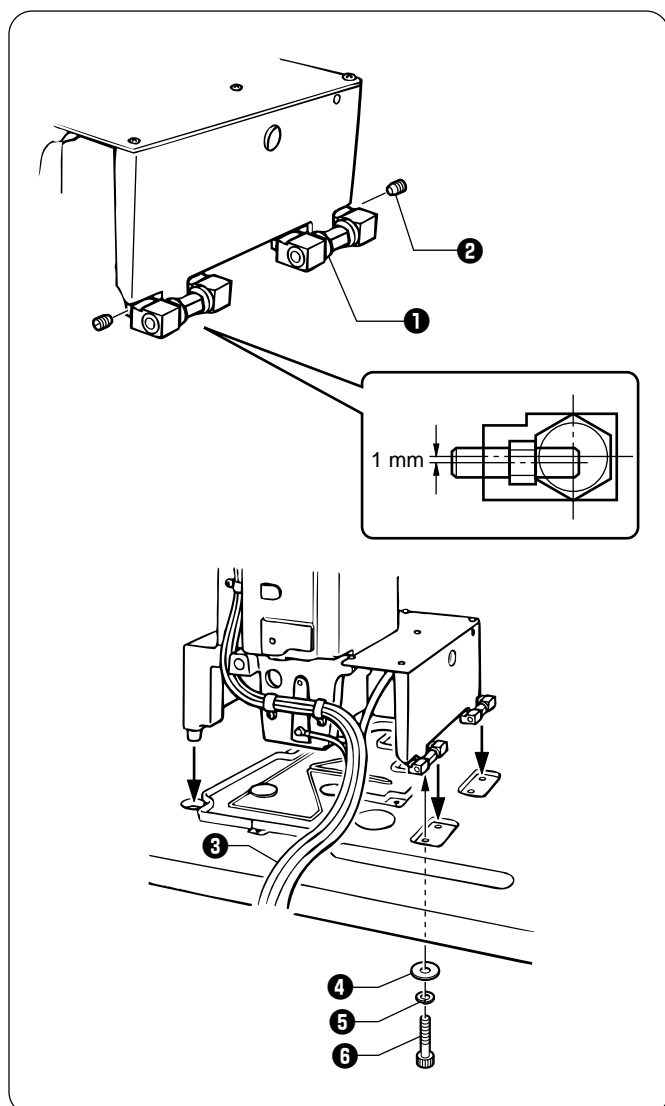

1. Insert the two hinge assemblies **1** into the machine head so that they are parallel, and then secure them with the two set screw **2**.

2. Place the machine head gently on the table.

NOTE: Pull the cords **3** out as shown in the illustration above in order to prevent them from being clamped by the machine head.

3. Secure the two hinge assemblies **1** with the washers **4**, the spring washers **5**, and the bolts **6**, and install the machine head.

3-8. Installing the head rest

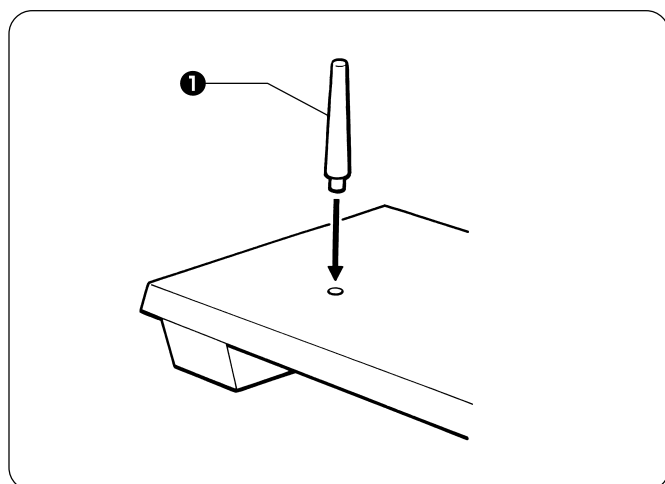

Tap the head rest **1** into the table hole.

NOTE:

Tap the head rest securely into the table hole.

3. Installation

3-9. Installing the liquid cooling tank, optional

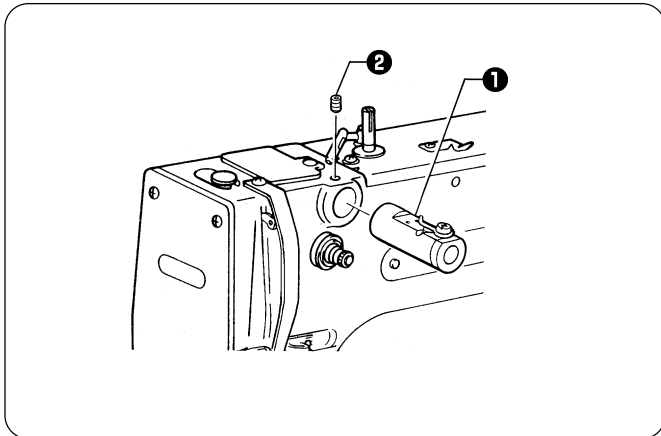

1. Remove the rubber plug, and then push the liquid cooling tank **1**.
2. Tighten it with the set screw **2**.

3-10. Installing the vibrating bowl

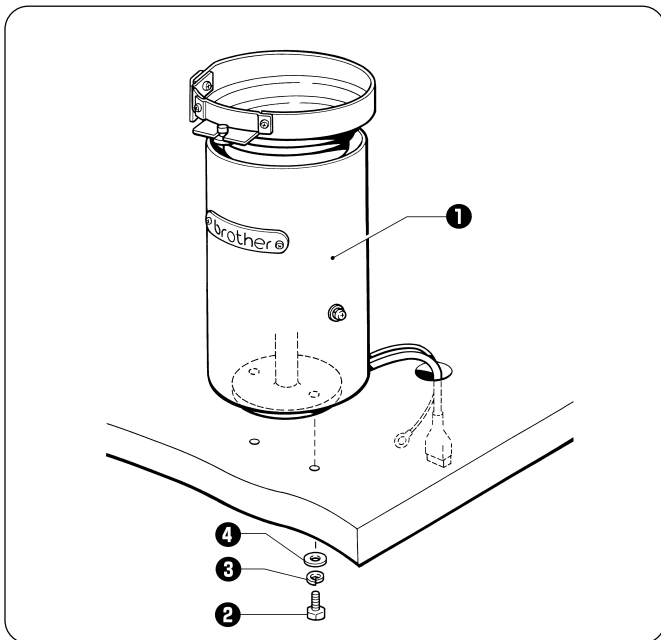

1. Install the vibration bowl **1** with bolts **2**, spring washers **3**, and washers **4**.
2. Pass the wires from the vibration bowl **1** through the hole in the table.

3-11. Installing the control box (for vibrating bowl)

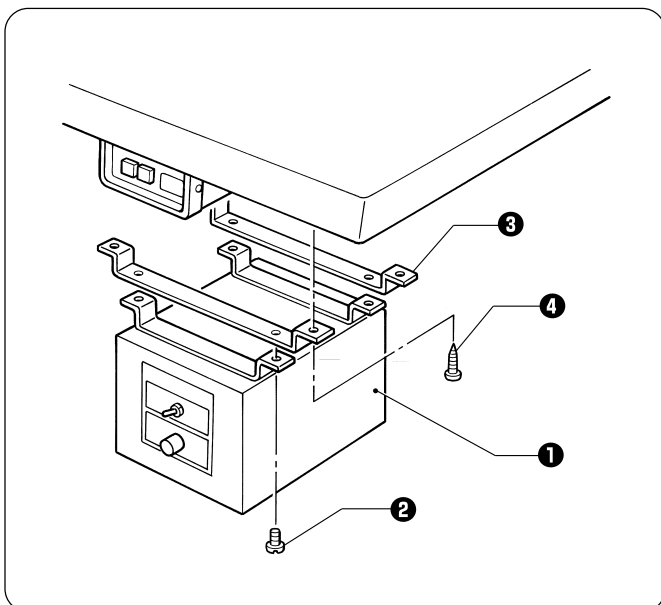

1. Mount the control box **1** to the bottom of the box stay **3** with screws **2**.
2. Mount the control box stay **3** to the bottom of the work table with wood screws **4**.

3-12. Installing the button feeder

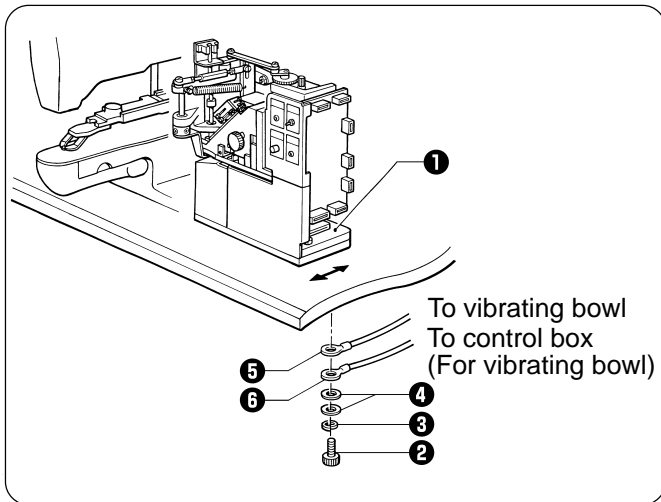

1. Move button feeder base **1** to the front and rear and left and right as necessary to install it by using hole bolts **2**, spring washers **3** and washers **4**. (And install ground wires **5 6**.)

3-13. Installing the shooter

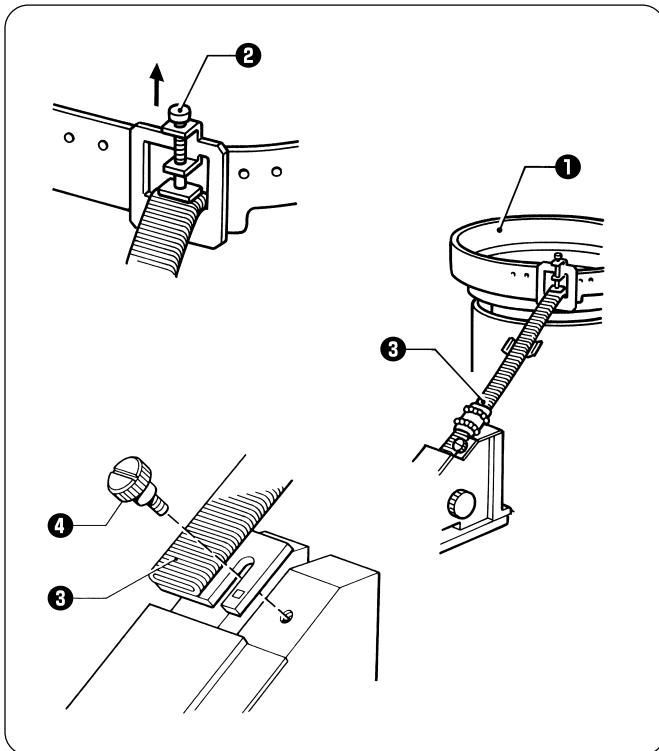

1. Raise the shooter lock pin **2** on the vibrating bowl **1**, and secure the shooter **3** by inserting the pin **2**, through the notch in the shooter.
2. Secure the shooter **3** with thumb screw **4** on button feeder **5**.

3. Installation

3-14. Connecting the cords

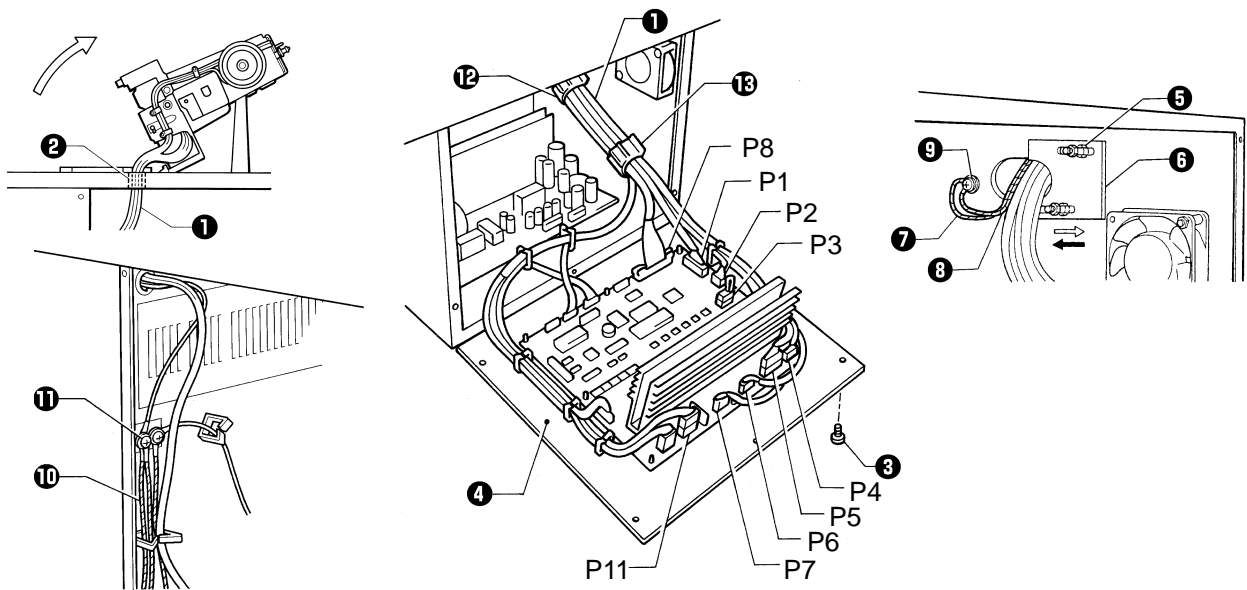

Machine head connectors			Connection location on circuit board
Connection location	No. of pins	Cord mark	
X, Y, Sewing sensor	12-pin	1	P1 (ORG2)
Synchronizer	5-pin	2	P2 (SYNCHRO)
Machine specification select connector	8-pin	3	P3 (SELECT)
Thread take-up solenoid	5-pin	4	P4 (SOL2)
Presser solenoid Thread trimmer solenoid	4-pin	5	P5 (SOL)
Pulse motor, Y	4-pin (blue)	6	P6 (YPM)
Pulse motor, X	4-pin	7	P7 (XPM)
Operation panel	26-pin	None	P8 (PANEL)
Upper shaft motor	3-pin	None	P11 (UVW)
BA16	1-pin	None	P14
BA16	16-pin	None	P15

1. Gently tilt back the machine head.

NOTE:

After tilting back the machine head, do not push the face side or the pulley side from above.

2. Pass the cords 1 through the hole 2 in the work table.
3. Gently return the machine head to its original position.
4. Remove the six screws 3, and then open the control box cover (main P.C. board mounting plate 4).

NOTE:

When opening the cover, hold it securely so that it does not fall down.

5. Loosen the two screws 5, and then open the cord presser plate 6 in the direction of the white arrow and pass the cords 1 through the opening.
6. Loosen the screw 9, and then attach the ground cord 7 for the machine head and the ground cord 8 for the operation panel as shown in the illustration.
7. Loosen the screw 11, and then attach the ground cord 10 for the upper shaft motor as shown in the illustration.
8. Securely connect connectors P1 to P8 and P11 as indicated in the table.
9. Secure the cords 1 with the cord clamps 12 and 13.
10. Close the cord presser plate 6 in the direction of the black arrow, and secure it by tightening the screws 5.

NOTE:

Check that the cords do not get pulled when the machine head is tilted back gently.

11. Tighten the cover (main P.C. board mounting plate 4) with the six screws 3.

■ Button feeder connection

Pull on the connector to make sure it will not come disconnected after connecting the pins.

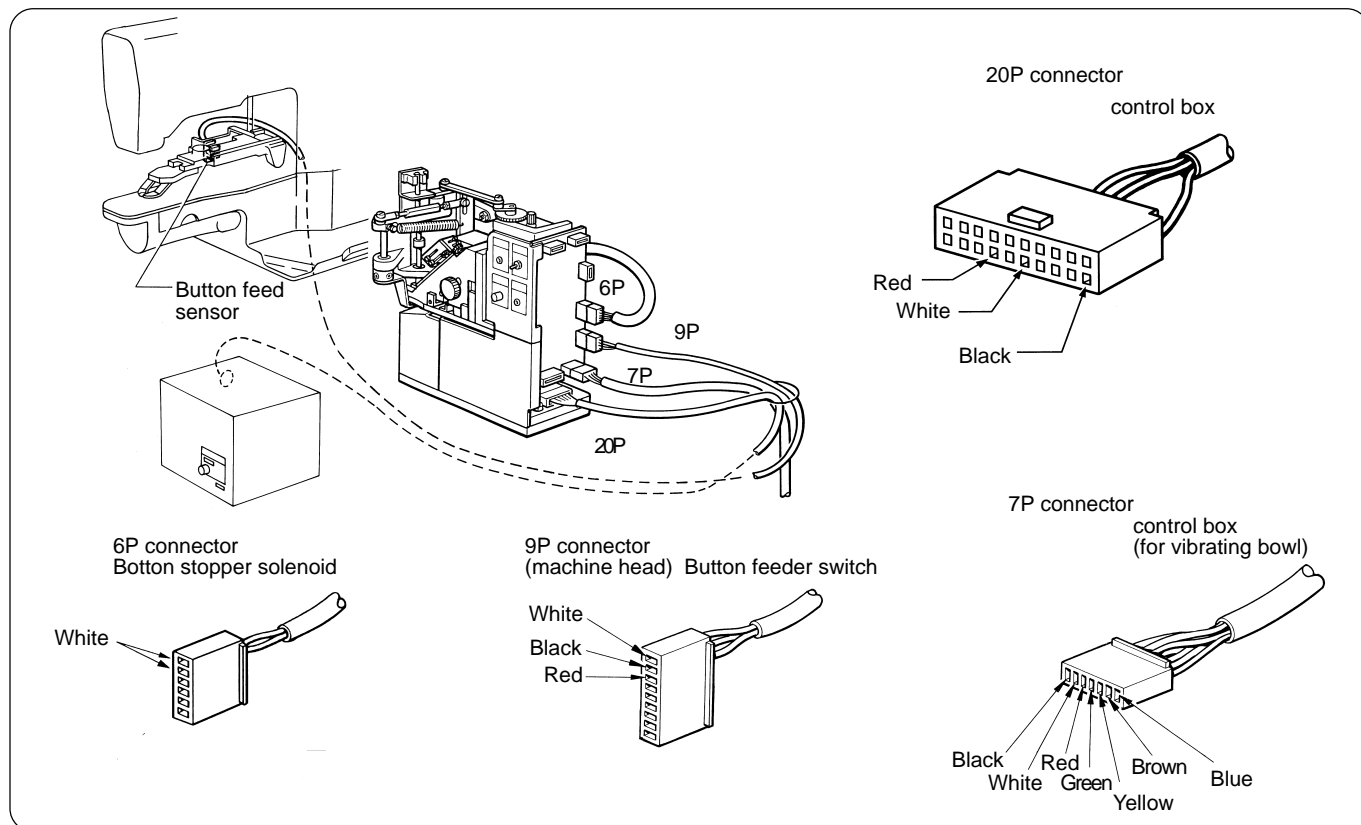

■ Control box (for vibrating bowl) connection

Connect the ground wire from the vibrating bowl to the motor.

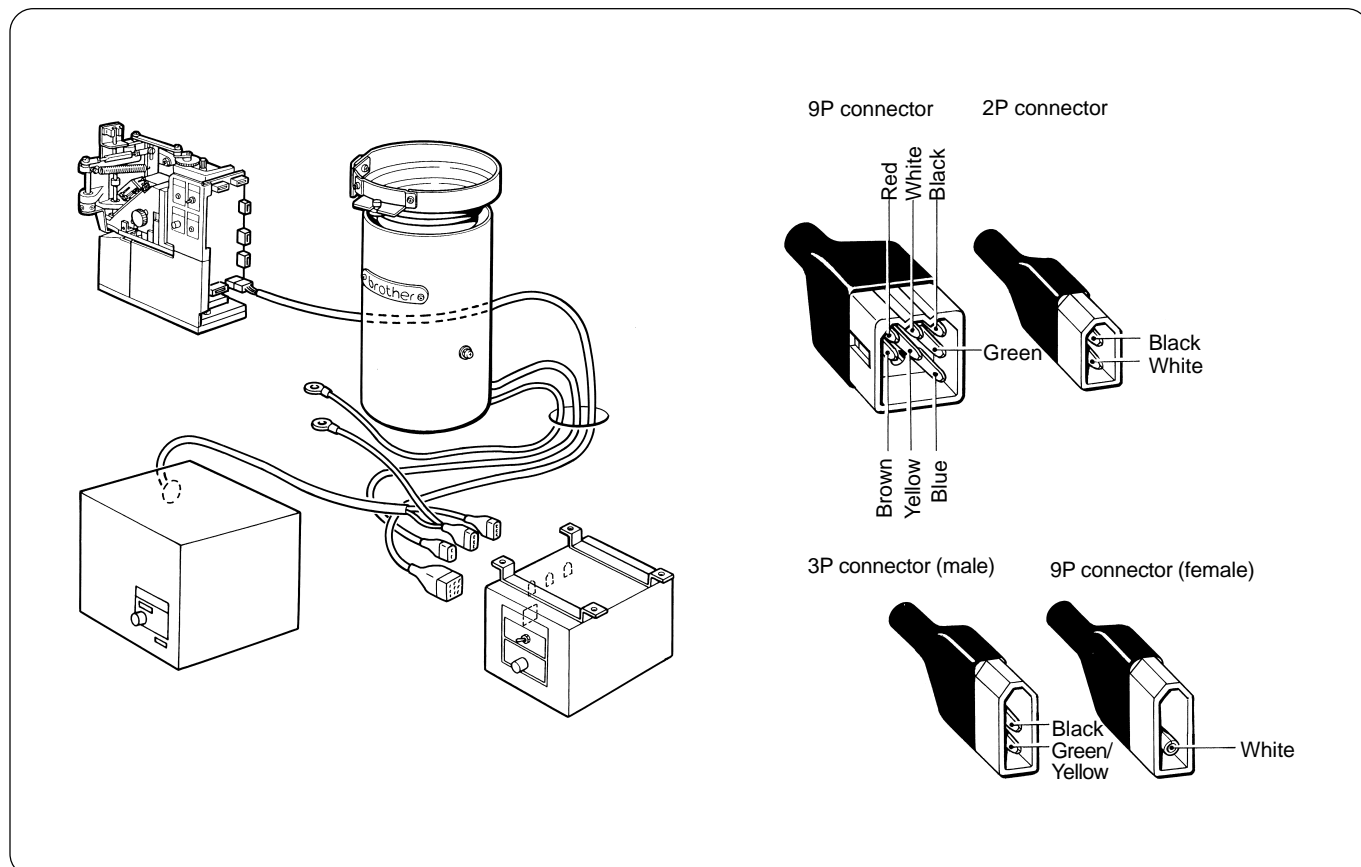

3. Installation

■ Power switch connection

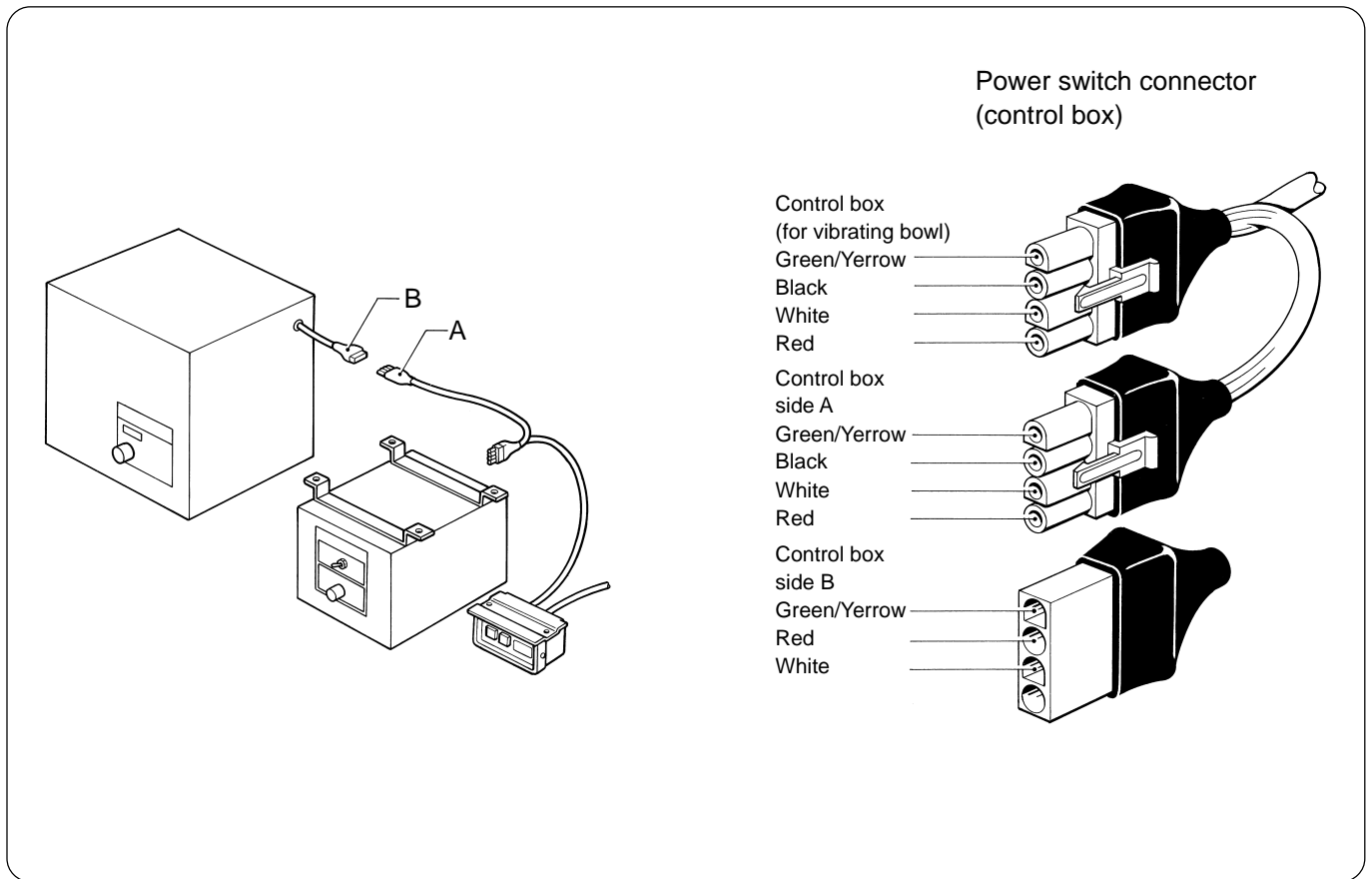

3-15. Installing the button feeder cover

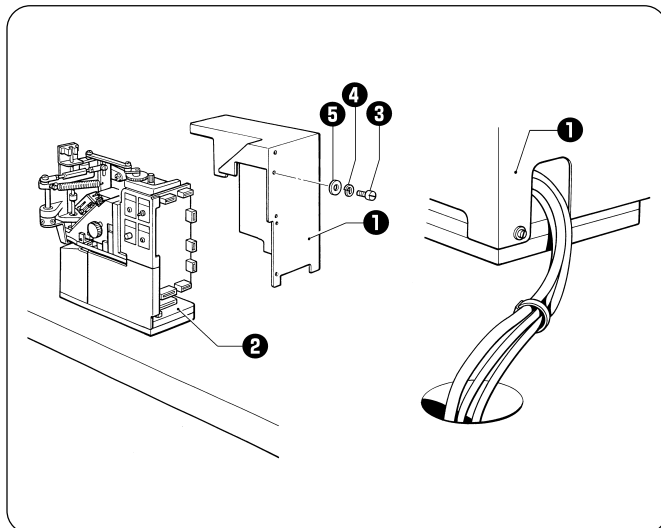

Attach the button feeder cover **1** to the button feeder **2** with screws **3**, spring washers **4**, and washers **5**.

* Be sure to pass the wires through the hole in the cover when attaching the button feeder cover **1**.

3-16. Installing the operation panel

The operation panel can be installed to either the top or bottom of the work table.

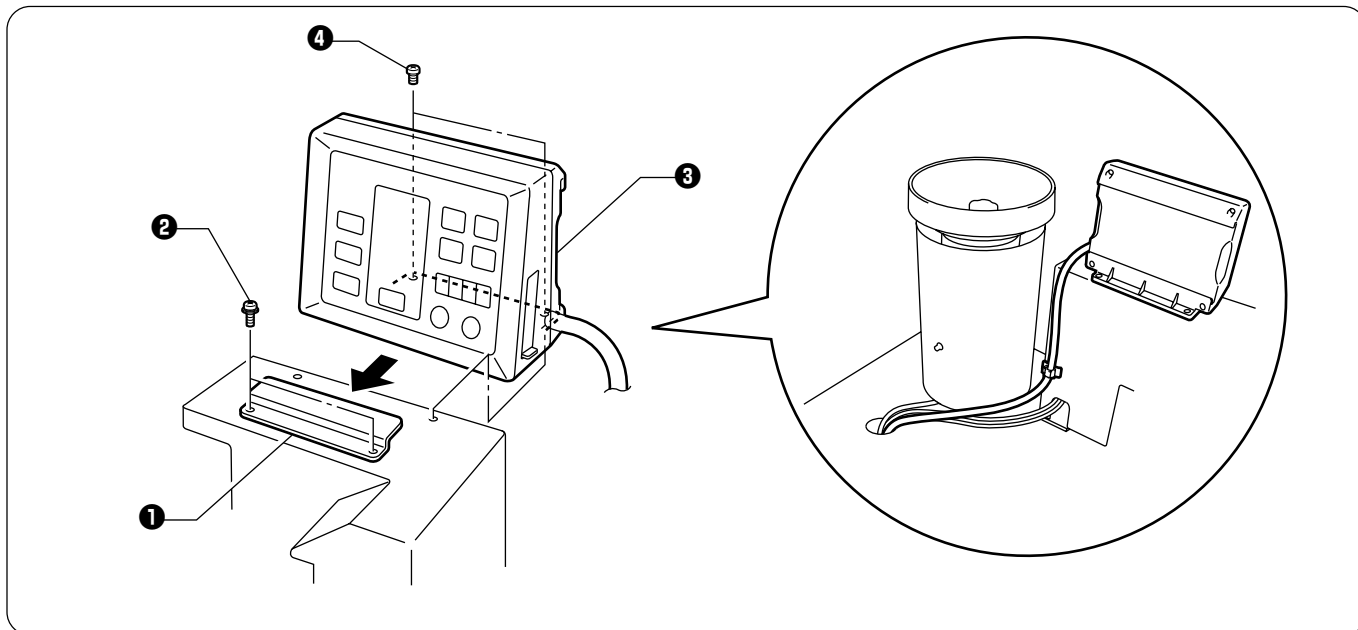

1. Install the operation panel presser plate **1** to the top of the button feeder cover with the two screws **2**.
2. Insert the panel **3** into the operation panel presser plate **1**, and then secure it with the two screws **4**.
3. Insert the connector cord **5** into the control box through the hole at the side of the box. Refer to “3-13. Connecting the cords” for details on connecting the cord.

3-17. Connecting the ground wire

CAUTION



Be sure to connect the ground. If the ground connection is not secure, you run the risk of receiving a serious electric shock, and problems with correct operation may also occur.

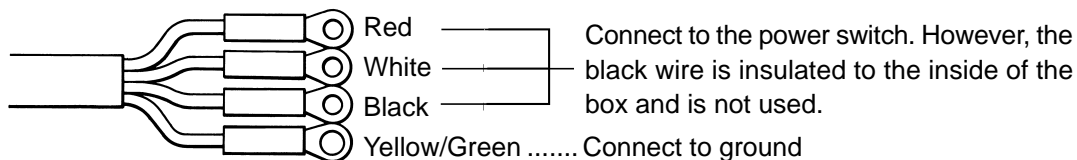

3. Installation

3-18. Installing the V-belt

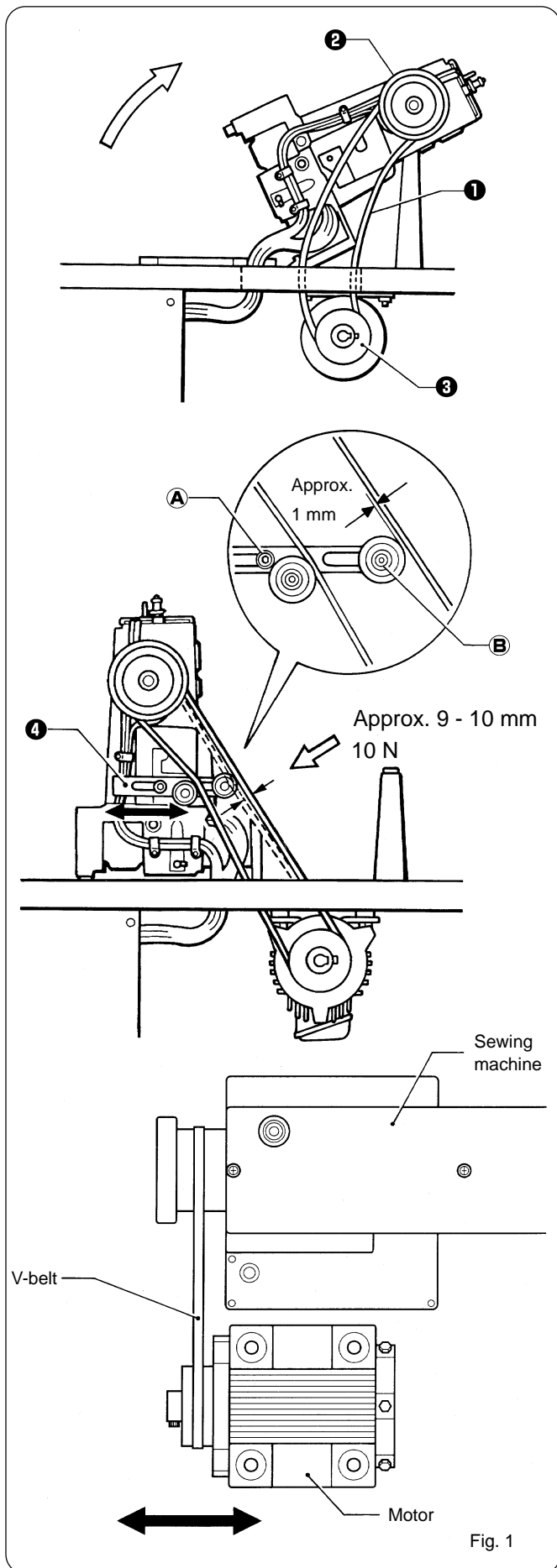

Fig. 1

1. Gently tilt back the machine head, and then place the V-belt ① into the V grooves on the machine head pulley ② and the motor pulley ③.

NOTE:

After tilting back the machine head, do not push the face plate side or the pulley side from above.

2. Gently return the machine head to its original position.
* Be careful not to clamp the cords at this time.
3. Provisionally install the assessorly tension pulley assembly ④ with the assessorly flat washer, spring washer and bolt.
4. Adjust the belt tension by moving the tension pulley assembly to the right and left so that there is 9-10 mm of deflection in the V-belt ① when it is gently pushed in the middle with a force of approximately 10 N. After adjusting, tighten the bolt A to secure the left pulley assembly.
5. Move the right tension pulley so that there is a gap of about 1 mm between it and the V-belt ①, and then tighten the bolt B to secure the right pulley assembly.

NOTE:

Use brother specified V-belt (belt, VM).

The V-belt ① may stretch slightly when it is first used, so adjust the belt tension after about 3,000 cycles of use.

When above belt tension is weak, this will be cause of following problems;

- Noise and vibration become large.
- Needle up stop position becomes unstable.
- Error message [E-5] is displayed.

Check that the motor is positioned so that the V-belt is straight. (Fig.1)

3-19. Installing the belt cover

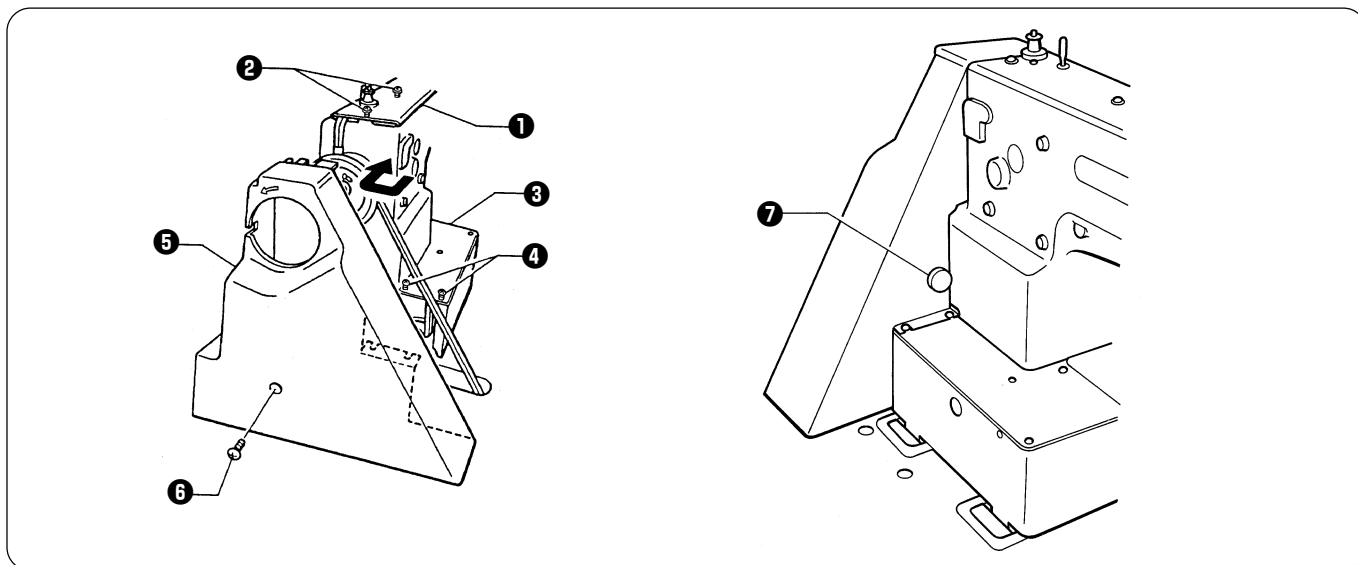

1. Loosen the two screws **2** of the upper cover **1** and the two screws **4** of bed cover L **3**.
2. Insert the belt cover **5** in the direction of the arrow, and then secure it with the two screws **2**.
 - * When tilting back the machine head, loosen the screws **2** and **4**, remove the screw **6** and then remove the belt cover **5** first.
3. Attach the rubber plug **7** to the belt cover.

3-20. Installing the foot switch

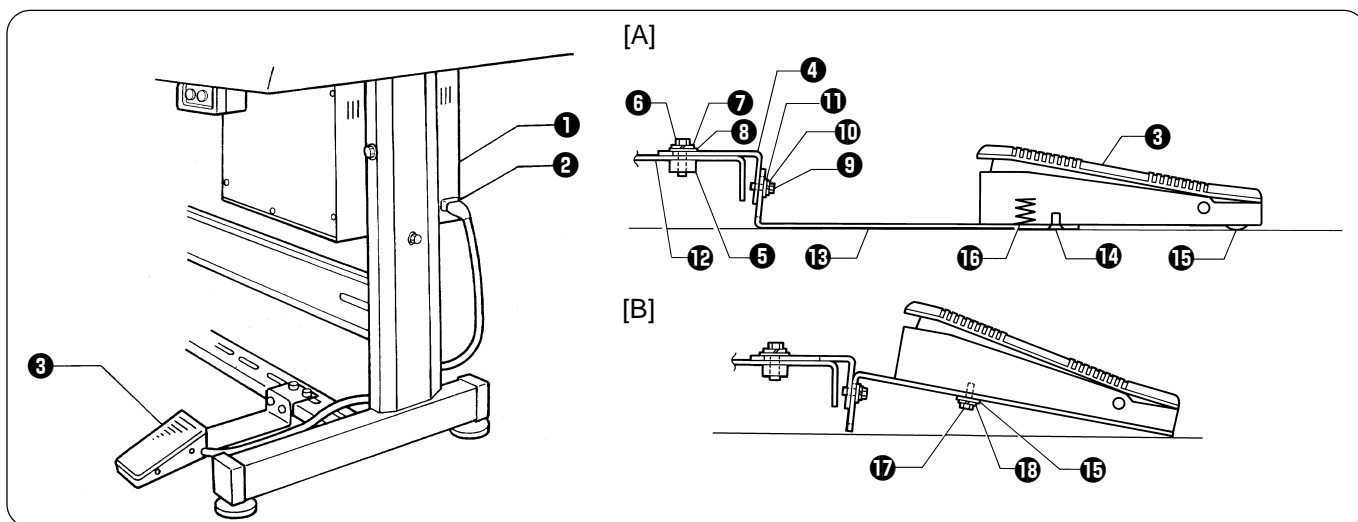

1. Insert the connector of the foot switch **3** into the connector **2** of the control box **1**.
2. Install the foot switch **3** to the work table leg **12** with foot switch support plate A **4**, foot switch support plate C **5**, the bolt **6**, spring washer **7**, flat washer **8**, bolt **9**, spring washer **10** and flat washer **11** as shown in Figure A.

If foot switch support plate B **16** is used in a back-to-front position, it can be used as shown in Figure B.

1. Remove the screw **14** and rubber plug **15**.
 - * Note that the spring **16** will come out when the screw **14** is removed.
2. Turn foot switch support plate B **16** back to front, and then install it with the bolt **17**, spring washer **18** and flat washer **19** as shown in Figure B.

NOTE:

If using the foot switch without installing it to the work table leg, move the foot switch at least 10 mm away from the leg. If the foot switch is not fully in contact with the work table leg when the foot switch is used, for example, if it is just hooked loosely onto the work table leg, it may cause the sewing machine to operate incorrectly.

If using the optional two-pedal foot switch, change the setting of DIP switch A on the operation panel while referring to "Setting the presser mode" on page 41.

3. Installation

3-21 . Installing the motor cover

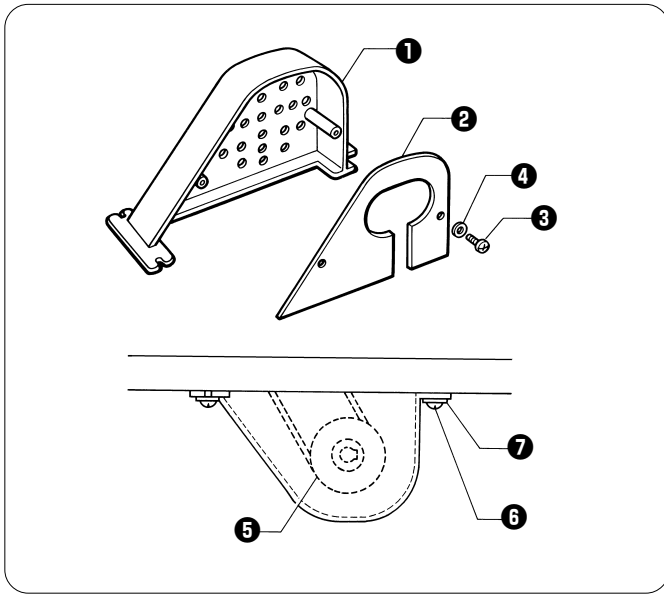

1. Install the motor cover **1** to the motor back cover **2** with the screws **3** and the flat washers **4**.
2. Pass the motor shaft through the notch in the motor back cover **2**, and then tighten the screws **6** and the washers **7** so that the clearance between the motor pulley **5** and the motor cover **1** is uniform.

3-22 . Installing the spool stand

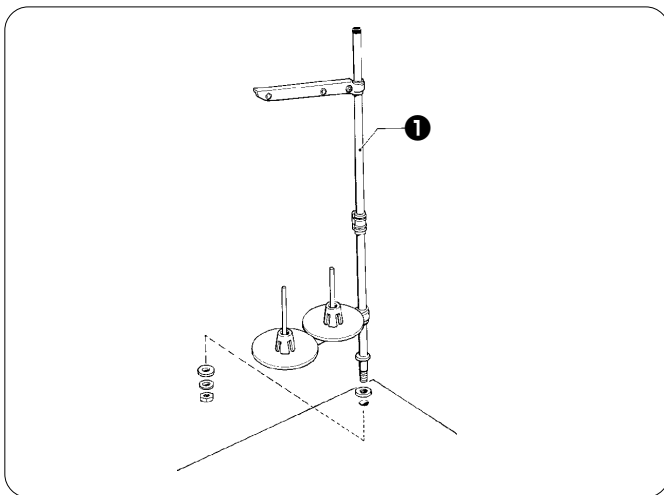

Assemble the spool stand **1** while referring to the spool stand instruction manual, and then install the spool stand **1** at the right side of the work table.

3-23 . Installing the eye guard

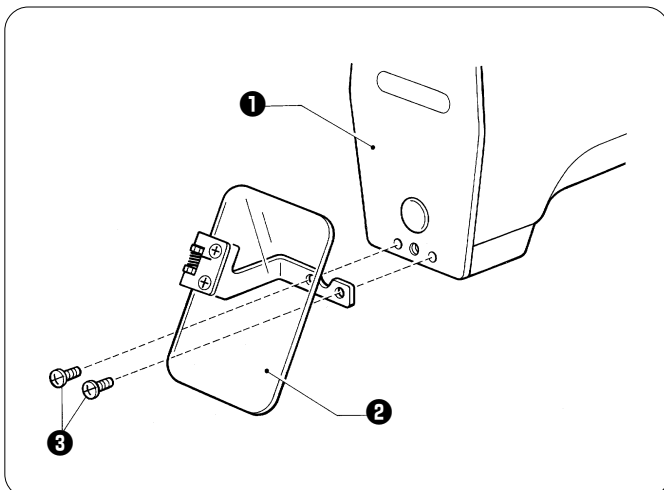

CAUTION



Attach all safety devices before using the sewing machine.
If the machine is used without these devices attached, injury may result.

Install the eye guard assy **2** to the face plate **1** with the two screws **3**.

3-24. Adjustment by the accessory spring

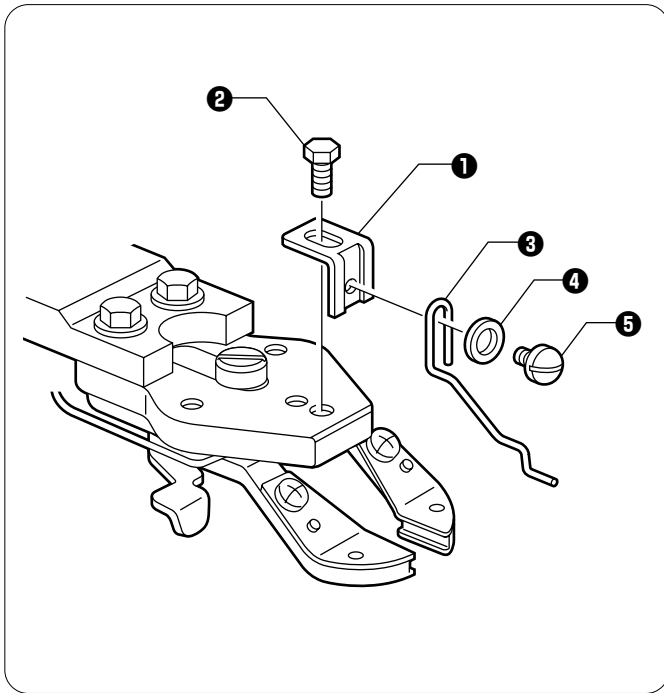

If you would like the button to be raised up more after it is sewn, install the accessory spring.

1. Install the spring support **1** with the bolt **2**.
2. Install the spring **3** with the washer **4** and the screw **5**.

* The spring is effective for use with the following sewing patterns:



1-6, 14-17, 20, 28-30, 32, 33, 46-49

* When using a solenoid-type thread wiper, the effective patterns are:

36-42

4. Lubrication

CAUTION

-  Turn off the power switch before starting lubricating, otherwise the machine may operate if the foot switch is depressed by mistake, which could result in injury.
-  Be sure to wear protective goggles and gloves when handling the lubricating oil and grease, so that they do not get into your eyes or onto your skin, otherwise inflammation can result.
Furthermore, do not drink the oil or eat the grease under any circumstances, as they can cause vomiting and diarrhoea.
Keep the oil out of the reach of children.

- NOTE :**
- Fill the machine with oil when the oil level is down to about one-third full in the oil sight glass.
If oil is not added and the oil drops below this level, there is the danger that the machine may seize during operation.
 - Be sure to let the machine operate for a while after adding the oil.
 - Use only specified Brother oil (Nisseki Sewing Lube 10) for the machine oil.

4-1 . Lubrication points

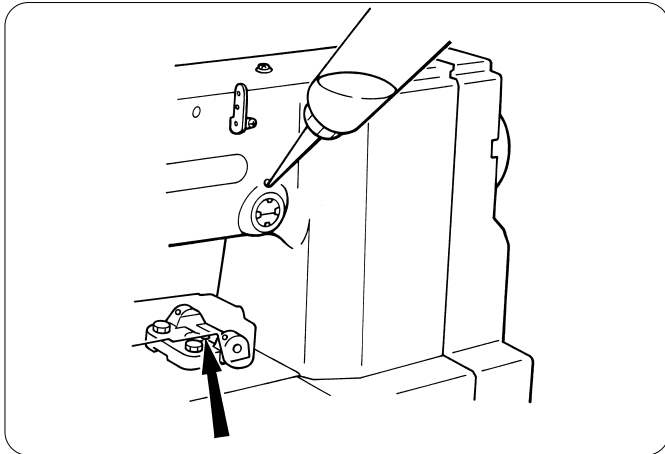

1. Fill the arm-side oil tank with oil.
* When setting up the sewing machine and when it hasn't been used for an extended period of time, be sure to add 2-3 drops of oil at the place indicated by the arrow.

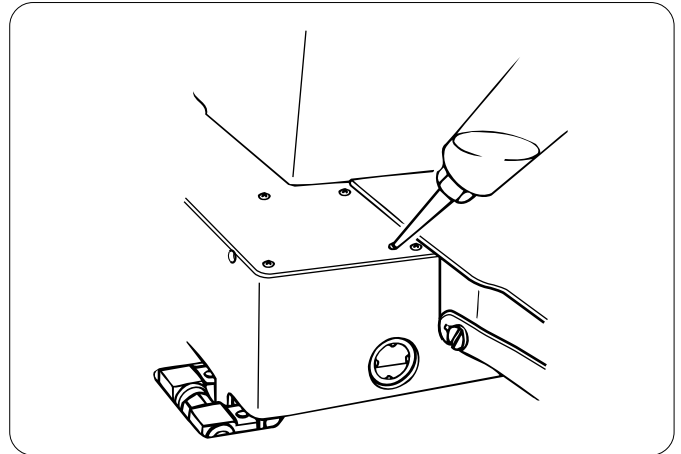

2. Fill the bed-side oil tank with oil

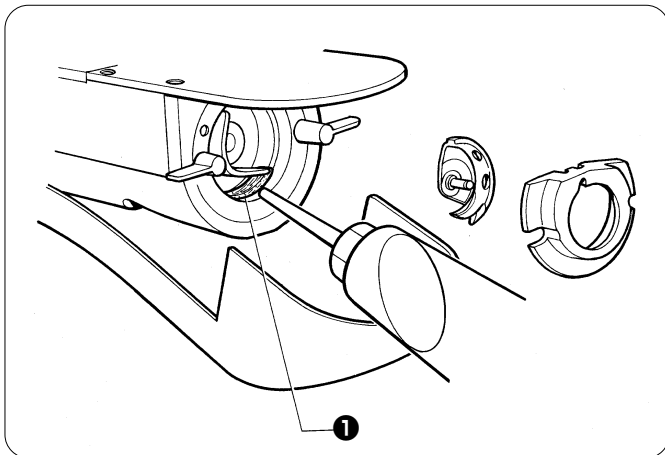

3. Add oil to the felt ❶ of the shuttle race base.
* When setting up the sewing machine and when it hasn't been used for an extended period of time, be sure to add 2-3 drops oil to the felt.

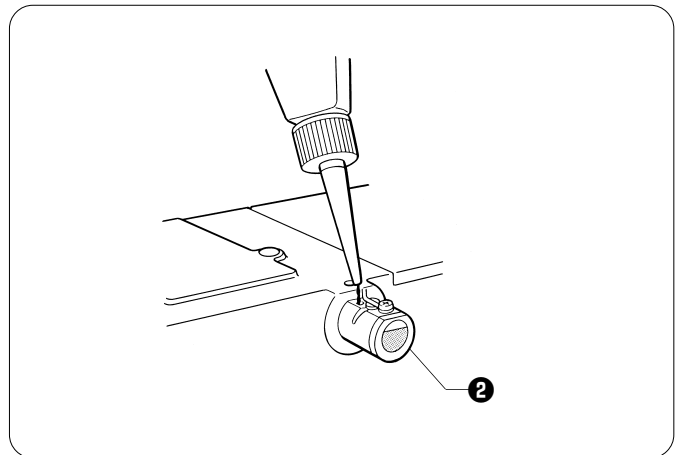

4. If using the liquid cooling tank ❷, fill it with silicon oil (100 mm²/s).

4-2. Applying grease

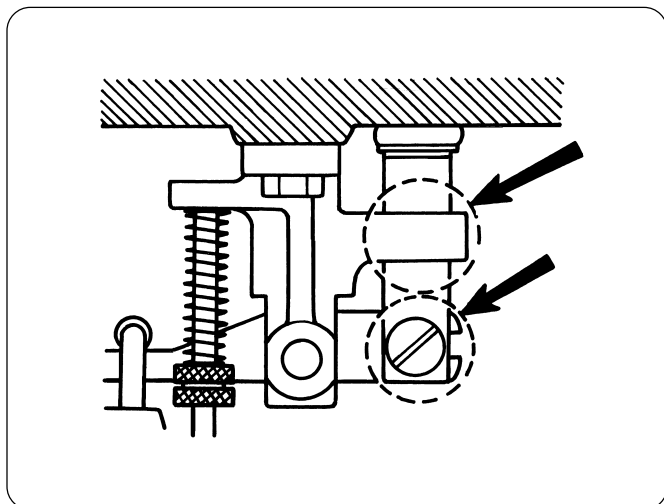

Do not apply too much grease in the place indicated by the arrow. If too much grease is applied here, the button clamp may not move up and down smoothly and error [E-6 □] may appear on the display.

4-3. Draining the oil

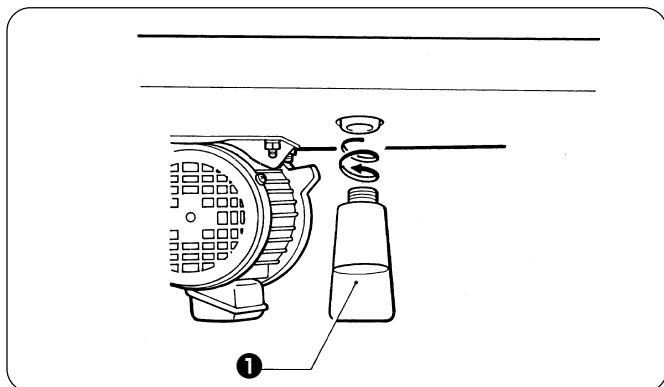

1. Remove and empty the waste oil container ❶ whenever it is full.
2. After emptying the waste oil container ❶, screw it back into its original position.

5 . Operation

5-1 . Name and function of each operation panel item

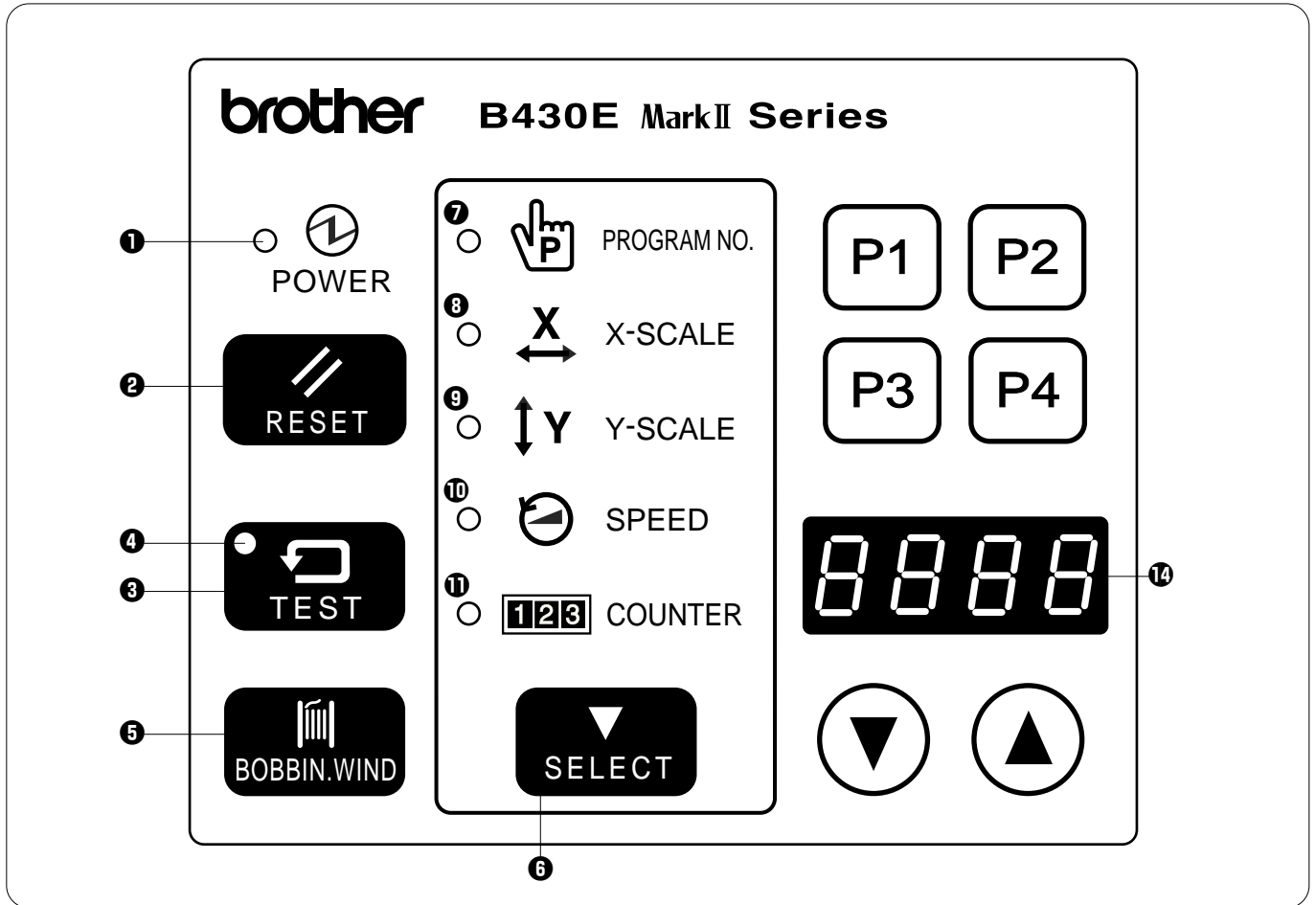

- ❶ POWER indicator Illuminates when the power switch has been turned on.
 - ❷ RESET switch Press this switch to reset the machine when an error occurs.
 - ❸ TEST switch Use this switch when you want to operate only the feed mechanism in order to check a pattern.
 - ❹ TEST indicator Illuminates when the TEST switch has been pressed.
 - ❺ BOBBIN. WIND switch Press this switch to wind the lower thread.
 - ❻ SELECT switch Use this switch to select a menu (program number, X and Y feed, speed and counter). Each time the switch is pressed, one of the menu indicators (❶ to ❺) illuminates, and the setting for that menu item appears in the display ❻. The illuminated indicator changes as follows each time the switch is pressed.
- ➔ PROGRAM NO. indicator ❶ → X-SCALE indicator ❷ → Y-SCALE indicator ❸ → SPEED indicator ❹ → COUNTER indicator ❺
- ❶ PROGRAM NO. indicator Illuminates when the SELECT switch ❷ is pressed to show the program number setting.

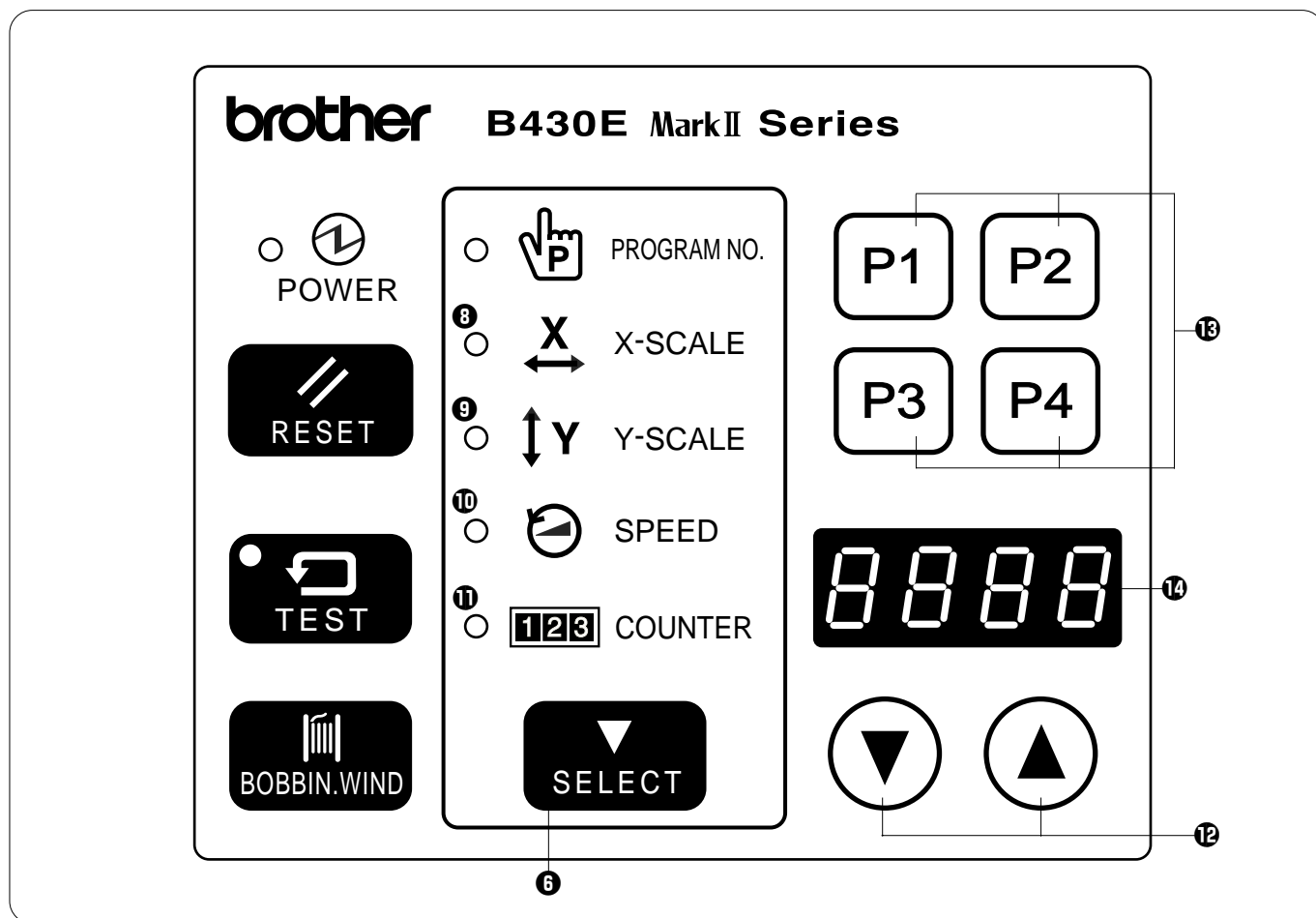

- ⑧ X-SCALE indicator Illuminates when the SELECT switch ⑥ is pressed to shown the X-scale setting.
- ⑨ Y-SCALE indicator Illuminates when the SELECT switch ⑥ is pressed to shown the Y-scale setting.
- ⑩ SPEED indicator Illuminates when the SELECT switch ⑥ is pressed to shown the speed setting.
- ⑪ COUNTER indicator Illuminates when the SELECT switch ⑥ is pressed to show the bobbin thread or production counter setting.
- ⑫ DISPLAY SET switches Used to change the menu details which are displayed in the window ⑭.
- ⑬ User program switches Used to set and select user programs.
- ⑭ Display window This display window will indicate the current status for the selected menu, error or memory switch.

5. Operation

5-2 . Operating procedure

NOTE:

Be sure to check the sewing pattern (refer to page 20) after setting has been completed to make sure that the needle drops down into the hole of the button.

Preparation

Turn on the power switch.
(The POWER indicator ❶ will illuminate and the program number will flash in the display window ❷.)

	Factory default	Variable range
Program No.	00 *	01 - 49
X-scale (%)	100	20 - 200
Y-scale (%)	100	20 - 200
Speed (rpm)	2000	1,000 - 2,500

* For checking the origin points for X and Y feed

5-2-1 . Setting the program number

Determine the appropriate program from the program list which is given on pp. 3 - 5.

1 Press the SELECT switch ❸ until the PROGRAM NO. indicator illuminates.

2 Press the DISPLAY SET switches ❹ until the desired program number is flashing in the display window.

3 Depress the foot switch to the second step.
* The display will stop flashing and illuminates steadily, and the feed mechanism will move to the sewing start position.

This completes the setting of the program number.

5-2-2 . Setting the X-scale and Y-scale

1 Press the SELECT switch ❸ until the X-scale or Y-scale indicator illuminates.

2 Press the DISPLAY SET switches ❹ until the desired scale setting is flashing in the display window. (The setting is displayed as a percentage.)

3 Depress the foot switch to the second step.
* The display will stop flashing and illuminates steadily, and the feed mechanism will move to the sewing start position.

This completes the setting of the X-scale or Y-scale.

5-2-3 . Setting the sewing speed

1 Press the SELECT switch ❸ until the SPEED indicator illuminates.

2 Press the DISPLAY SET switches ❹ until the desired speed setting is flashing in the display window.

5-3. Operating the button feeder

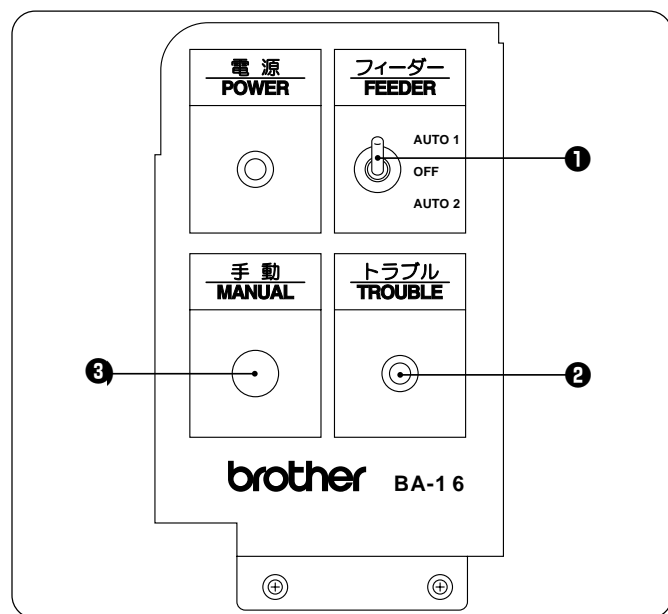

1. Button feeder switch ❶
 - AUTO1 ... Buttons are supplied automatically after sewing is complete.
 - AUTO2 ... When sewing is complete and the button clamp releases its button, the next button is supplied.
 - OFFButtons are not supplied automatically.
2. Trouble indicator ❷
 - (1) When buttons are being fed to the button clamp, the trouble indicator ❷ will be OFF.
 - (2) When the trouble indicator ❷ is flashing, buttons are not supplied to the button clamp.
 - (3) If the trouble indicator ❷ is on, a problem has occurred. See below.
3. Manual switch ❸
 - Press to feed a button.

5-4. Operating the vibrating bowl

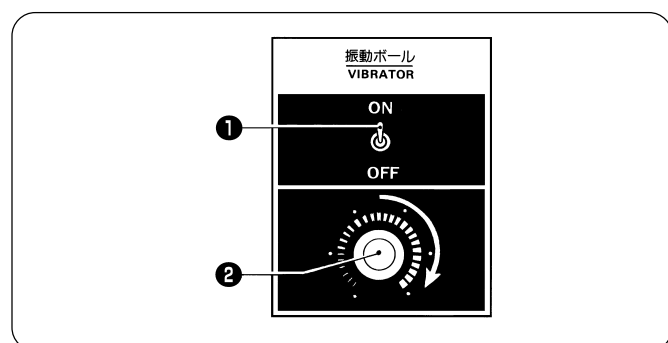

1. Turn the power switch on.
2. Turn the switch ❶ in the control box on.
3. Turn the adjustment knob ❷.
 - Turn the knob right to increase and left to decrease the amount of vibration of the vibrating bowl.

6. Checking the sewing pattern

6. Checking the sewing pattern

■ When checking by operating only the feed mechanism

1. Turn on the power switch.

(The POWER indicator will illuminate and the program number will flash in the display window.)

2. Depress the foot switch to the second step.

(After the home position is detected, the button clamp will rise.)

3. Set the button. (Press the MANUAL switch on the button feeder.)

4. Set the X-scale and Y-scale in accordance with the hole pitch of the buttons being used.

(Refer to "5-2-2. Setting the X-scale and Y-scale".)

5. Press the TEST switch.

(The TEST indicator will illuminate.)



6. If the setting was not changed in step 4, proceed to step 7.

Depress the foot switch to the second step.

(Home position detection will be carried out. The work clamp will not rise because this is test mode.)

7. Depress the foot switch to the second step.

Only the feed mechanism will move.

The feed mechanism moves forward by one stitch each time the foot switch is depressed.

Each time the feed mechanism is moved forward by one stitch, turn the machine pulley by hand and check that the needle goes into the holes in the button without touching the button. Do this for each hole position. (NOTE)

After checking is complete, depress the foot switch to move the feed mechanism to the end position.

* If you depress the foot switch to the 2nd step and keep it depressed until after the feed mechanism has started to move, the feeding speed will increase.

* If you would like to stop the feed while it is moving, press the TEST switch.

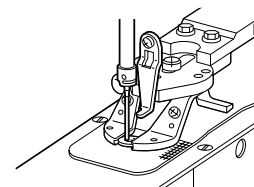
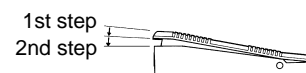

8. Press the TEST switch.

(The TEST indicator will switch off and the test mode will be cleared.)



9. Depress the foot switch.

The work clamp will rise and the preparation for sewing will be completed.

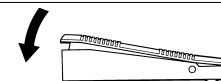

NOTE: If the needle touches the button, carry out the following.

1. Check that the needle size correctly matches the diameter of the holes in the button. (Refer to "7-1. Selecting the needle and thread".)

2. Make fine adjustments to the X-scale and Y-scale. (Refer to "5-2-2. Setting the X-scale and Y-scale".)

3. Adjust the position of the button holder. (Refer to "10-10. Adjusting the position of the button holder".)

To ensure safety during use

You can prevent accidental changes being made to programs by setting DIP switches 7 and 8 to ON.

When DIP switch 7 is ON

... The sewing pattern cannot be enlarged.

When DIP switch 8 is ON

... The program number cannot be changed.

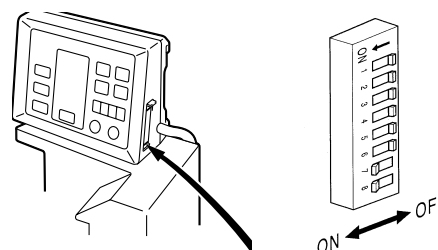

7. Correct use

7-1 . Selecting the needle and thread

Refer to the table at right for details on which needle and thread to select.

NOTE: Use buttons which have a hole diameter that is greater than the value given in the table, to ensure that the needle does not touch the button.

Needle	Thread	Button hole diameter
TQ × 1 #11	#60	1.5mm or greater
TQ × 1 #12		1.6mm or greater
TQ × 1 #14	#50	1.7mm or greater

7-2 . Installing the needle

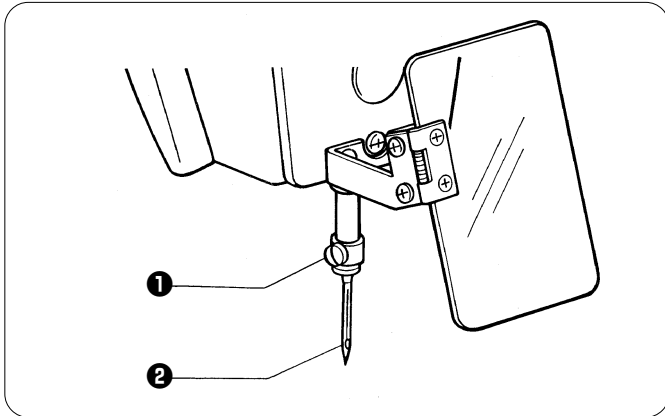

⚠ CAUTION



Turn off the power switch before installing the needle, otherwise the machine may operate if the foot switch is depressed by mistake and serious injury could result.

Loosen the set screw **1**, insert the needle **2** as far as it will go so that the groove is facing toward you, and then tighten the set screw **1**.

7-3 . Threading the upper thread

⚠ CAUTION



Turn off the power switch before threading the thread, otherwise the machine may operate if the foot switch is depressed by mistake and serious injury could result.

Thread the upper thread correctly as shown in the illustration below.

* If the tension release lever **1** is raised in the direction of the arrow, it will be easier to open the tension disc **2** and pull the thread through.

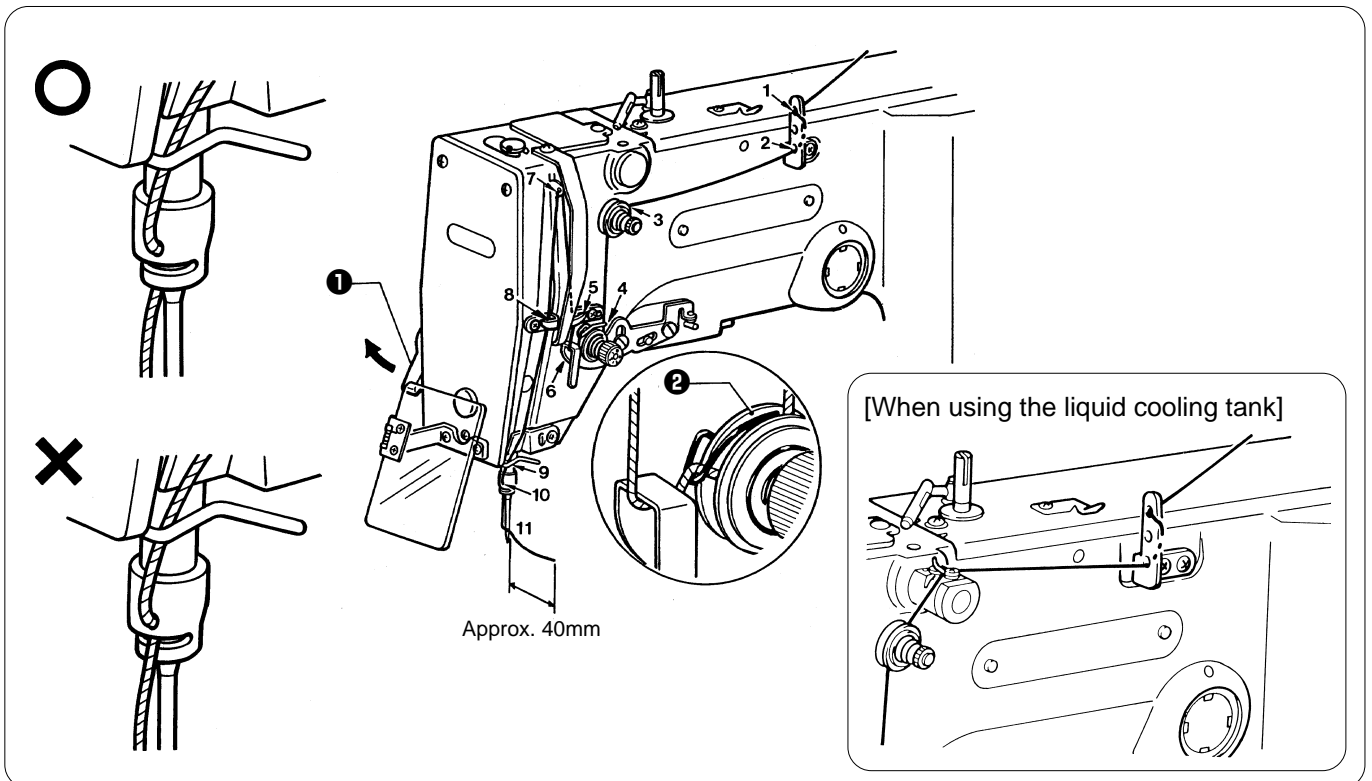

7. Correct use

7-4 . Winding the lower thread

⚠ CAUTION



Do not touch or place anything against any of the moving parts while winding the lower thread, otherwise personal injury or damage to the machine may result.

1. Place the bobbin all the way onto the shaft.



2. Thread the thread as shown in the illustration at right, wind the thread around the bobbin several times in the direction of the arrow, and then press the bobbin presser ①.



3. Turn on the power switch.
(The POWER indicator on the operation panel will illuminate.)



4. Check that the button is not inserted and the needle does not touch the button clamp, and then while pressing the BOBBIN. WIND switch ②, depress the foot switch ③ to start the machine. Keep depressing the foot switch ③ until the lower thread stops being wound onto the bobbin.

[Release the BOBBIN. WIND switch ② after the machine starts operating. If you release the foot switch before winding is completed, depress it once more while pressing and holding the BOBBIN. WIND switch ②.]

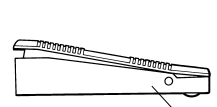
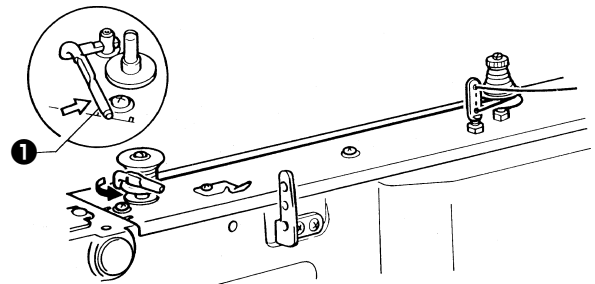

5. The bobbin presser ① will automatically return to its original position after a set amount of thread (80 - 90% of the bobbin capacity) has been wound on.



6. Release the foot switch ③.



7. Remove the bobbin, hook the thread onto the knife ④, and then pull the bobbin in the direction of the arrow to cut the thread.

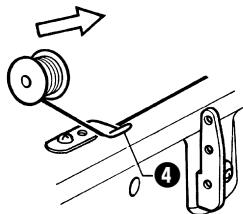

8. To wind more thread onto the bobbin, loosen the set screw ⑤ and pull the bobbin presser ① outward.

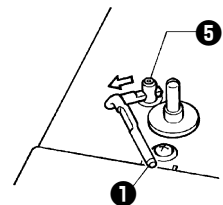

<< If the thread winds onto the bobbin unevenly >>

If the thread winds onto the bobbin unevenly, loosen the nut ① and turn the bobbin winder thread tension stud ② to adjust.

* If the thread winds on as shown in A, turn the bobbin winder thread tension stud ② clockwise; if it winds on as shown in B, turn the bobbin winder thread tension stud ② counterclockwise.

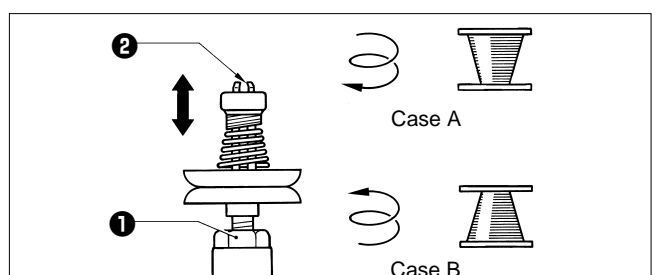

7-5. Replacing the bobbin case and threading the thread

⚠ CAUTION

Turn off the power switch before removing and replacing the bobbin case, otherwise the machine may operate if the foot switch is depressed by mistake and serious injury could result.

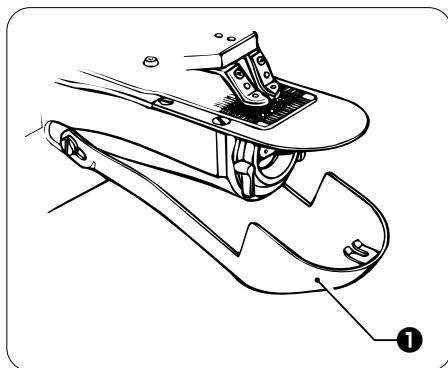

Pull the shuttle race cover **1** toward you to open it.

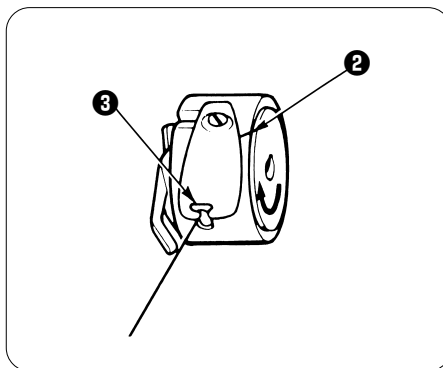

Insert a new bobbin into the bobbin case, and then pass the thread through thread hole **3**. Check that the bobbin turns in the direction of the arrow when the thread is pulled at this time.

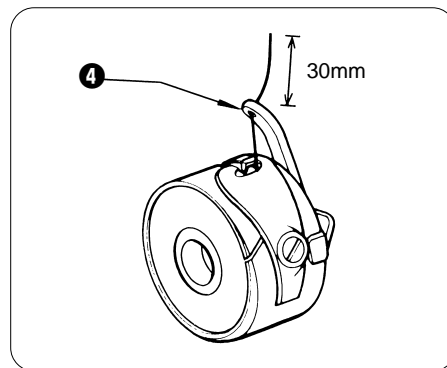

Pass the thread through the lever thread hole **4**, and then pull out approximately 30 mm of thread.

7-6 . Thread tension reference guide

Thread	#60 or equivalent
Upper thread tension (N)	0.7 - 1.3
Lower thread tension (N)	0.3 - 0.4
Thread take-up spring height (mm)	6 - 8

Thread take-up spring tension (mm)	0.4 - 0.6
Pre-tension (N)	0.1 - 0.3
Needle	TQ × 1#12

7-6-1 . Lower thread tension

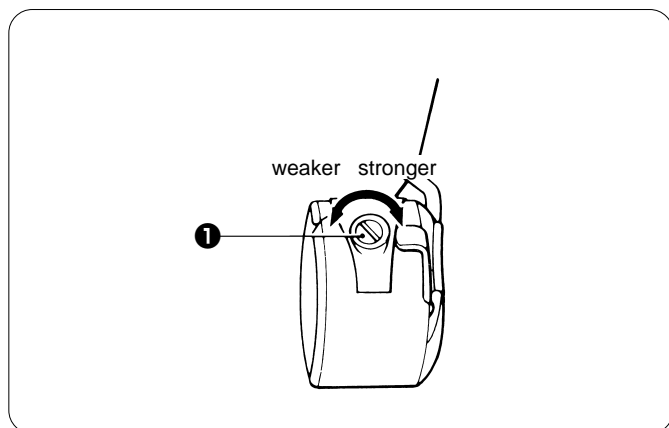

Adjust the thread tension to the weakest possible tension by turning the thread tension nut **1** until the bobbin case will not drop by its own weight while the thread end coming out of the bobbin case is held.

7-6-2 . Upper thread tension

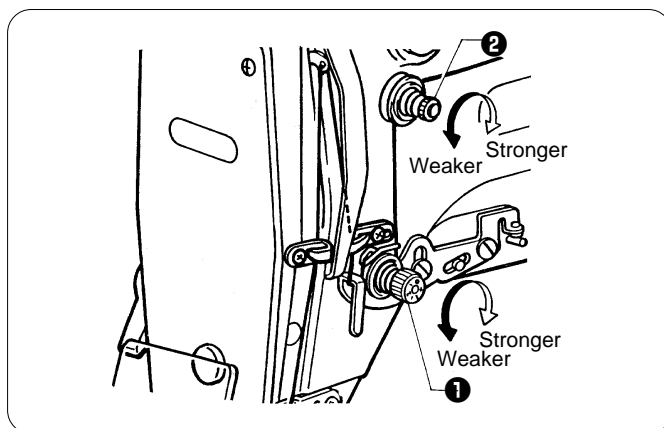

Turn the tension nut **1** (main tension) to adjust the tension as appropriate for the material being sewn. Furthermore, turn the thread nut **2** (sub-tension) to adjust the remaining length of upper thread to 35 - 40 mm when the thread take-up lever is not used.

7. Correct use

7-6-3 . Thread take-up spring height

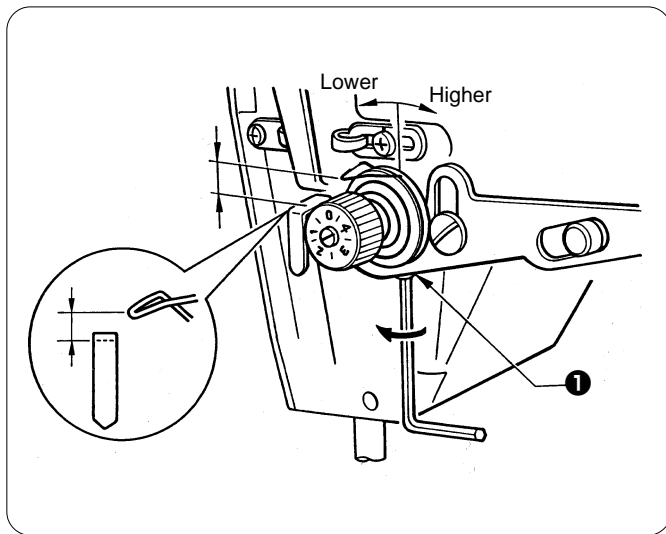

Loosen the set screw ❶ and turn the tensioner body to adjust the thread take-up spring height.

7-6-4. Thread take-up spring tension

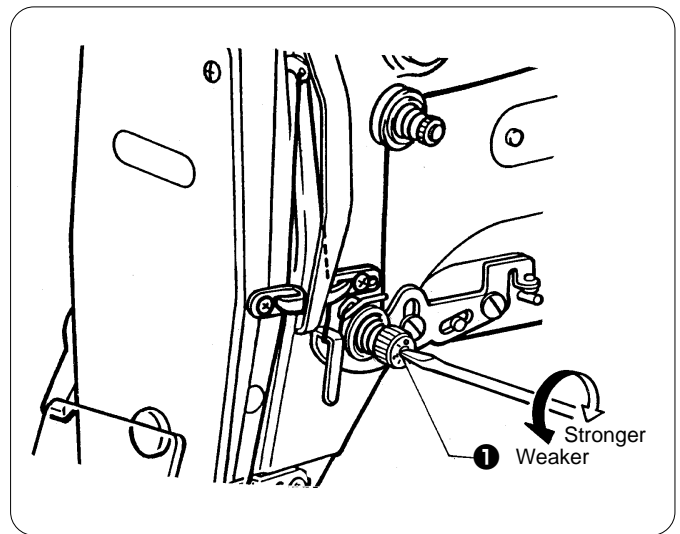

Turn the tension stud ❶ with a screwdriver.

7-6-5. Adjusting arm thread guide R

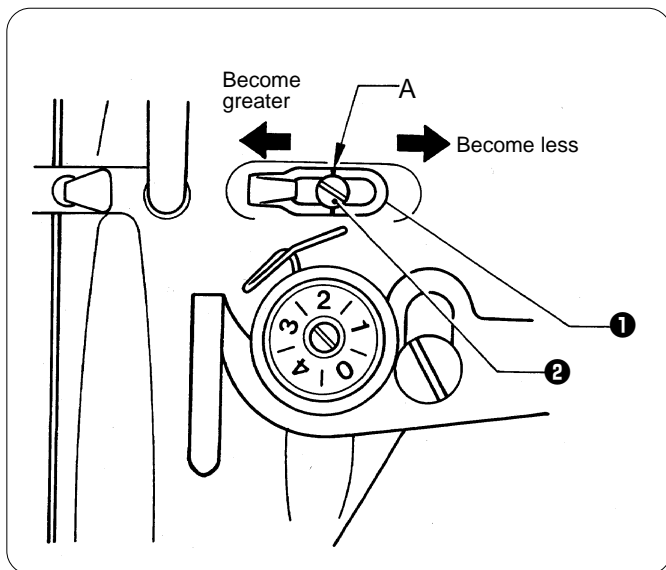

The standard position of arm thread guide R ❶ is when the screw ❷ is aligned with mark A.

To adjust the position, loosen the screw ❷ and then move arm thread guide R ❶.

- * When sewing thick material, move arm thread guide R ❶ to the left. (The thread take-up amount will become greater.)
- * When sewing thin material, move arm thread guide R ❶ to the right. (The thread take-up amount will become less.)

7-6-6. Thread take-up amount

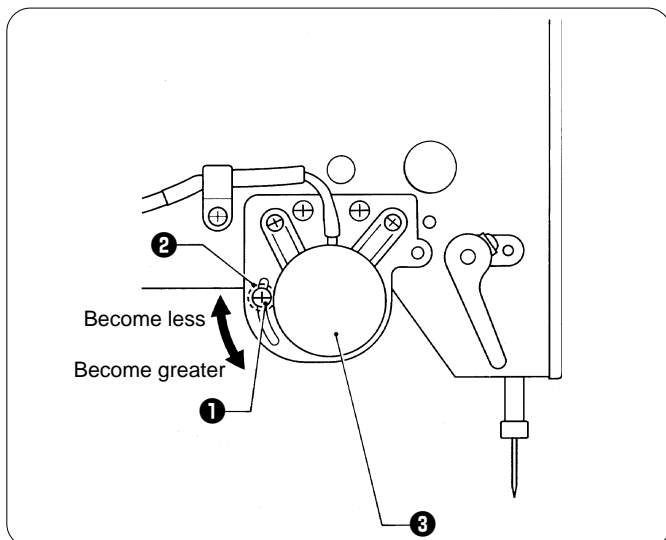



Loosen the screw ❶ and move the stopper (3.57 nut) ❷ to adjust the operating angle of the thread take-up solenoid ❸.

- * To reduce the thread take-up amount, move the stopper ❷ upward.
- * To increase the thread take-up amount, move the stopper ❷ downward.

8. Sewing

CAUTION

-  Turn off the power switch at the following times, otherwise the machine may operate if the foot switch is depressed by mistake, which could result in injury.
- Threading
 - When replacing the bobbin and needle
 - When not using the machine and when leaving the machine unattended
-  Do not touch any of the moving parts or press any objects against the machine while sewing, as this may result in personal injury or damage to the machine.

Before starting sewing...

- Check that the needle bar is at its highest position.
Turn the machine pulley so that the index mark **1** on the pulley is between the marks **2** on the belt cover.
- * If the stop position of the machine pulley is not correct, error [E-50] will be displayed, because the wiper may come into contact with the needle and this may cause the tip of the needle to break.

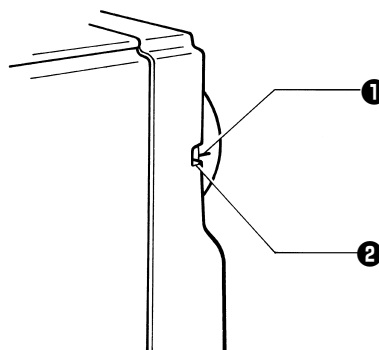

1. Turn on the power switch
(The POWER indicator will illuminate and the program number will flash in the display.)



2. Depress the foot switch to the 2nd step.
(The feed mechanism will move to the starting position and the button clamp will rise.)
* Note that if the foot switch is pressed to the 2nd step while the display is illuminated, the machine will start operating.

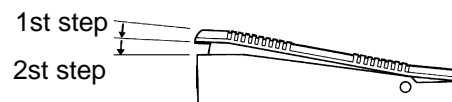

3. Install the button. (Press the MANUAL switch.)



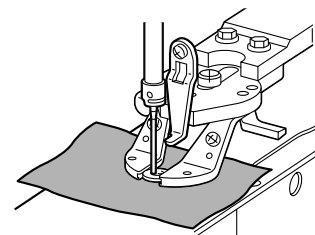

4. Place the material to be sewn under the button clamp, and then depress the foot switch.
When the foot switch is pressed to the 1st step, the button clamp will lower.
If you would like to shift the position of the material, release the foot switch.
The button clamp will then rise again.



5. Once sewing is completed and the thread has been trimmed, the button clamp will rise.
* Depending on the sewing data, thread trimming may be carried out or the button clamp may rise during sewing, but the rest of the sewing will still be carried out automatically.

9. Maintenance and inspection

⚠ CAUTION

-  Turn off the power switch before starting any cleaning work, otherwise the machine may operate if the foot switch is depressed by mistake, which could result in injury.
-  Be sure to wear protective goggles and gloves when handling the lubricating oil and grease, so that they do not get into your eyes or onto your skin, otherwise inflammation can result. Furthermore, do not drink the oil or eat the grease under any circumstances, as they can cause vomiting and diarrhoea. Keep the oil out of the reach of children.

9-1. Cleaning the rotary hook

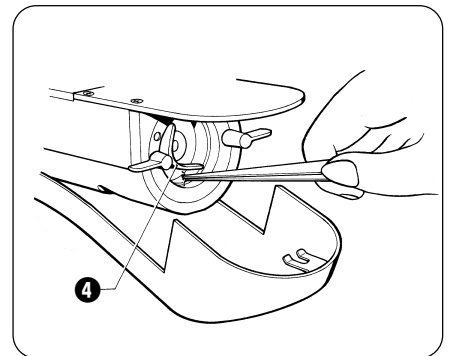
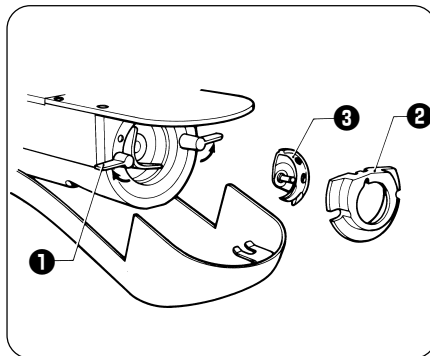
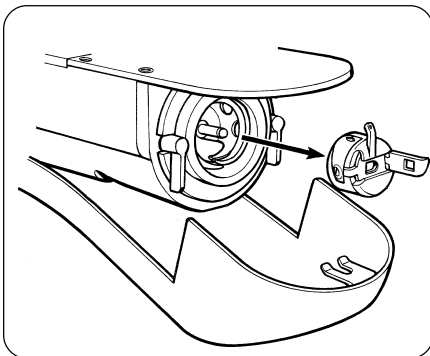

1. Pull the large shuttle hook cover toward you to open it, and then remove the bobbin case.
2. Open the large shuttle hook set claw **1** in the direction indicated by the arrow, and then remove the large shuttle hook **2** and the inner rotary hook **3**.
3. Clean all the dust and thread ends from around the driver **4**, the top of the rotary hook thread guide and the shuttle race.

9-2. Cleaning the control box air inlet port

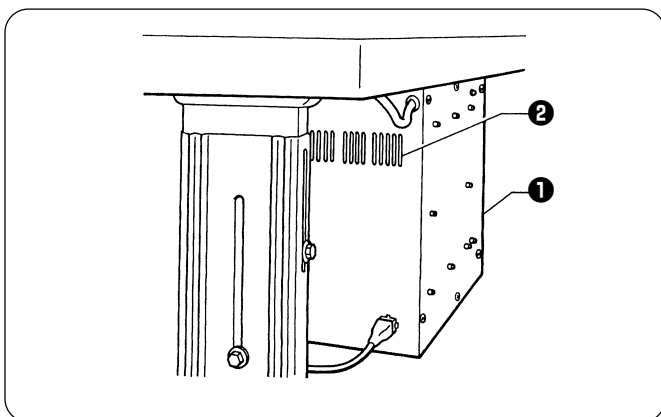

Use a vacuum cleaner to clean the filter in the air inlet port **2** of the control box **1** at least once a month.

* If the machine is used while the air inlet port is blocked, the inside of the control box will overheat.

When this happens, the overheating error code [E-d0] will be displayed and you will not be able to operate the sewing machine.

9-3. Cleaning the eye guard

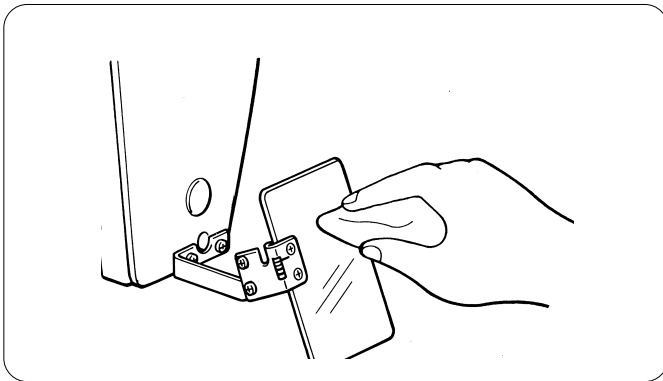

Wipe the eye guard clean with a soft cloth.

NOTE:

Do not use solvents such as kerosene or thinner to clean the eye guard.

9-4. Checking the needle

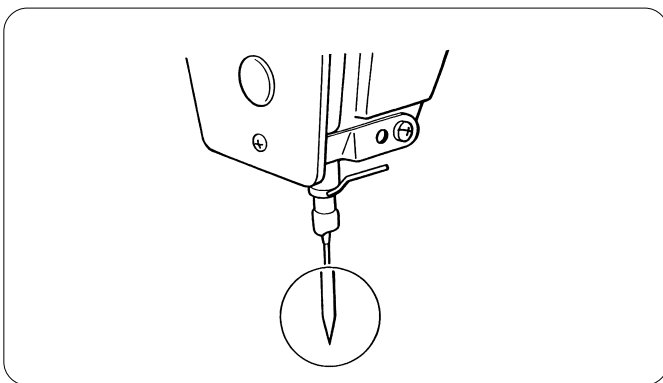

Always check that the tip of the needle is not broken and also the needle is not bent before starting sewing.

10 . Adjustments

⚠ CAUTION

- ⊘ Maintenance and inspection of the sewing machine should only be carried out by a qualified technician.
- ❗ Ask your Brother dealer or a qualified electrician to carry out any maintenance and inspection of the electrical system.
- ⚠ Turn off the power switch and disconnect the power cord from the wall outlet at the following times, otherwise the machine may operate if the foot switch is depressed by mistake, which could result in injury.
 - When carrying out inspection, adjustment and maintenance
 - When replacing consumable parts such as the rotary hook and knife

- ⚠ Hold the machine head with both hands when tilting it back or returning it to its original position. Furthermore, after tilting back the machine head, do not push the face plate side or the pulley side from above, as this could cause the machine head to topple over, which may result in personal injury or damage to the machine.
- ⚠ If the power switch needs to be left on when carrying out some adjustment, be extremely careful to observe all safety precautions.
- ❗ If any safety devices have been removed, be absolutely sure to re-install them to their original positions and check that they operate correctly before using the machine.

■ Tilting back the machine head

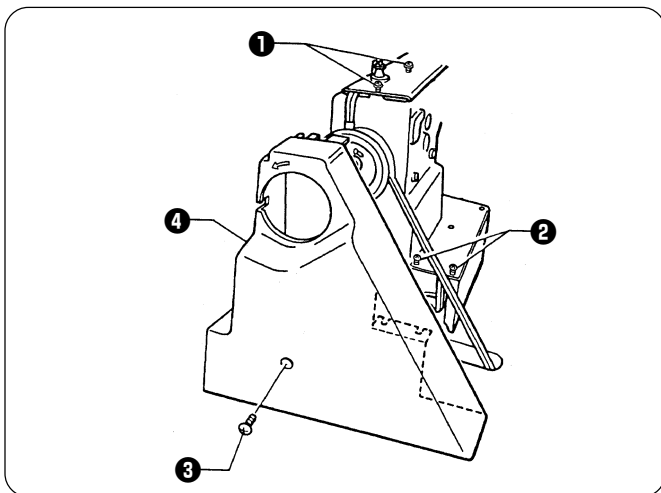

1. When tilting back the machine head, loosen the screws ① and ②, remove the screw ③ and then remove the belt cover ④ first.

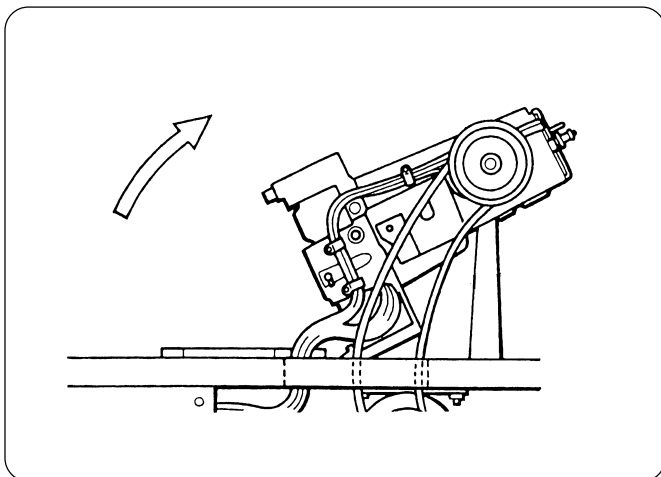

2. Gently tilt back the machine head in the direction of the arrow.

NOTE:

- After tilting back the machine head, do not push the face plate side or the pulley side from above.
 - Gently return the machine head to its original position.
- Be careful not to clamp the cords at this time.

10-1 . Adjusting the needle bar height

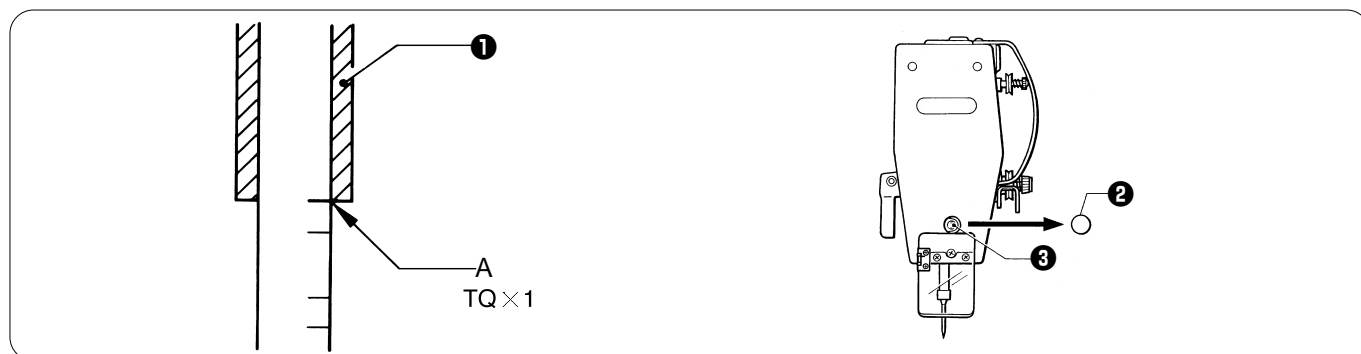

Turn the machine pulley to move the needle bar to the lowest position. Then remove the rubber plug (2), loosen the set screw (3) and then move the needle bar up or down to adjust so that the highest reference line (reference line A) is aligned with the lower edge of the needle bar bush (1).

10-2 . Adjusting the needle bar lift amount

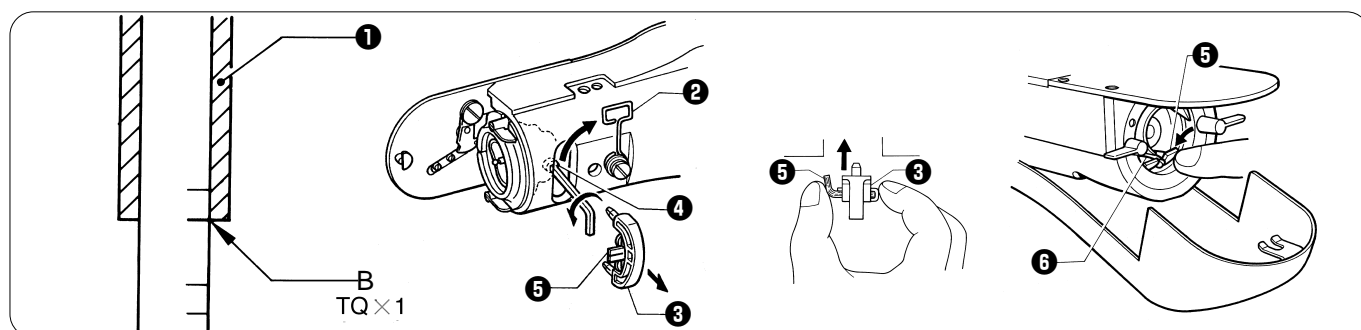

Adjust the needle bar lift amount as described below so that the tip of the rotary hook is aligned with the center of the needle when the machine pulley is turned to raise the needle bar from its lowest position until the second reference line from the top of the needle (reference line B) is aligned with the lower edge of the needle bar bush (1).

1. Open the support (2) in the direction of the arrow, and remove the felt support (3).
2. Loosen the screw (4), and move the driver to adjust so that the tip of the rotary hook is aligned with the needle center line.

* When returning the felt support (3), place it as shown in the illustration so as not to clamp the felt (5), and then gently press the felt (5) and the wick (6) until they are at the same height as the rotary hook race.

* Return the support (2) to its original position.

10. Adjustments

10-3 . Adjusting the driver needle guard

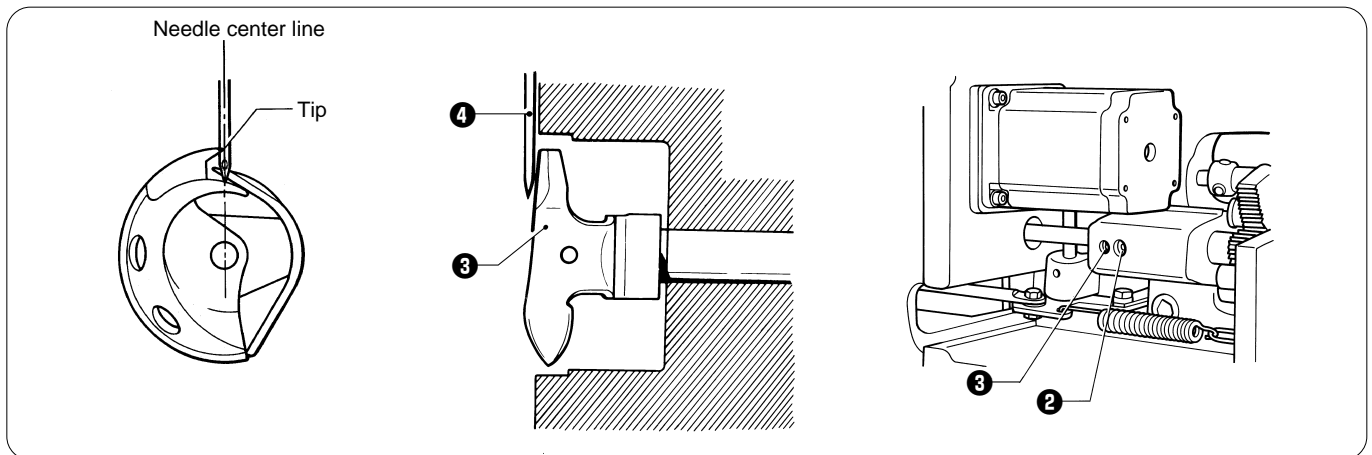

Turn the machine pulley to align the tip of the rotary hook with the needle center line. Then loosen the set screw **2** and turn the eccentric shaft **3** to adjust so that the driver needle guard **1** contacts the needle.

If the needle contact pressure is too great, skipped stitches may occur. On the other hand, if the driver needle guard **1** is not touching the needle, the tip of the inner rotary hook will obstruct the needle, resulting in an excessively high amount of friction.

10-4 . Adjusting the needle clearance

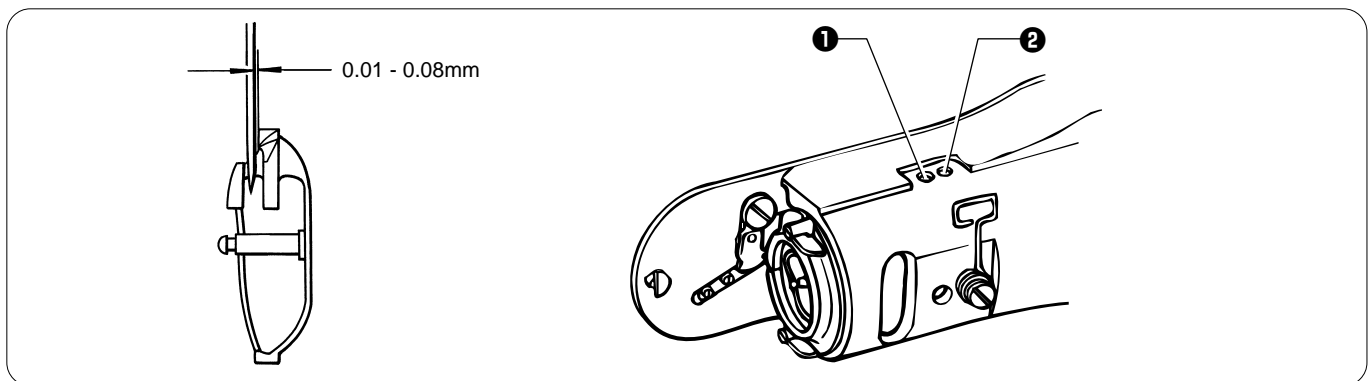

Turn the machine pulley to align the tip of the rotary hook with the needle center line. Then loosen the set screw **1** and turn the eccentric shaft **2** to adjust so that the clearance between the needle and the rotary hook is 0.01 - 0.08 mm.

10-5 . Adjusting the shuttle race thread guide

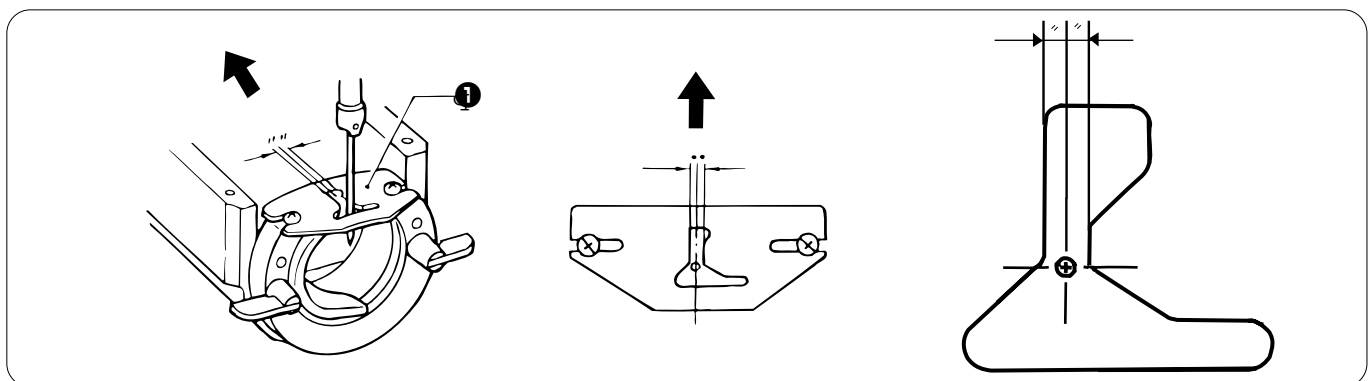

Install the shuttle race thread guide **1** by pushing it in the direction of the arrow so that the needle groove is aligned with the center of the needle plate hole.

NOTE:

If the shuttle race thread guide is in the wrong position, thread breakages, soiled thread or catching of the thread may occur.

10-6. Adjusting the thread take-up amount

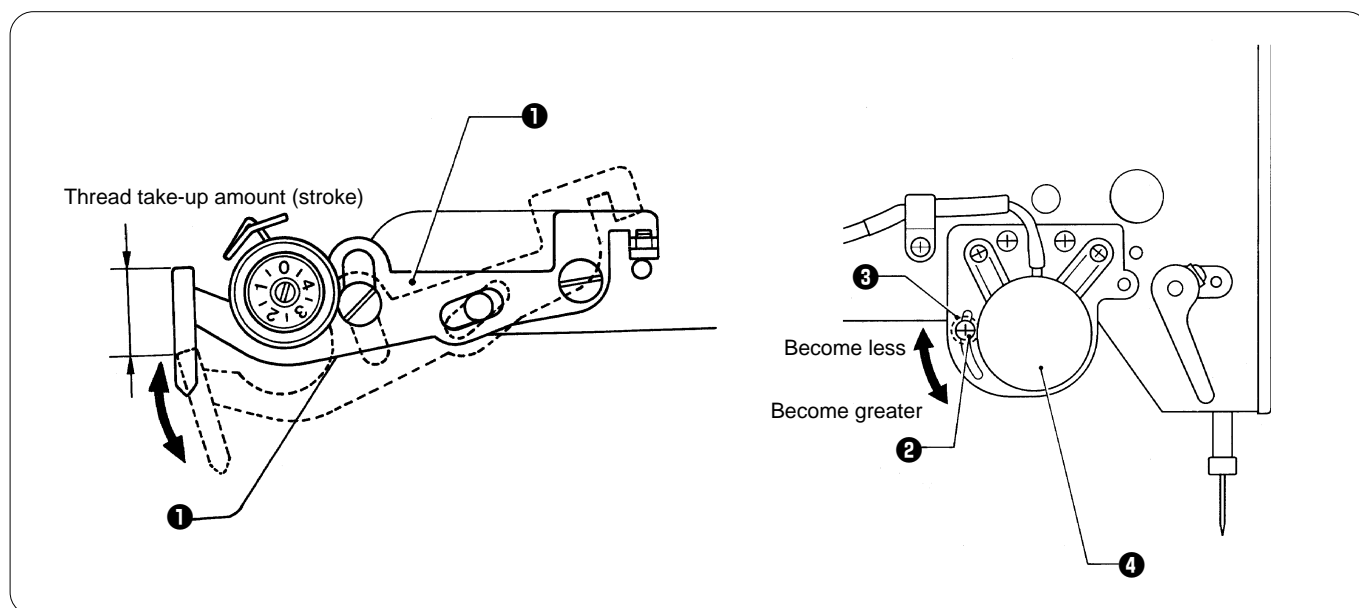

At the time of shipment from the factory, the thread take-up amount (stroke) of the thread take-up lever **1** is set to the standard setting of 5 mm. You may need to adjust this setting depending on the sewing conditions to prevent the thread from pulling out at the sewing start.

[Adjustment method]

Loosen the screw **2** and move the stopper (3.57 nut) **3** to adjust the operating angle of the thread take-up solenoid **4**.

* To reduce the thread take-up amount, move the stopper **3** upward.

* To increase the thread take-up amount, move the stopper **3** downward.

NOTE:

Do not increase the stroke of the thread take-up lever any more than is necessary.

If the sub-thread tension is too high, the needle thread length may become too short and the thread may come out of the needle. Furthermore, if the sub-thread tension is too weak, the needle thread length may become too long and the underside of the article being sewn may become untidy.

10-7 . Adjusting the movable knife

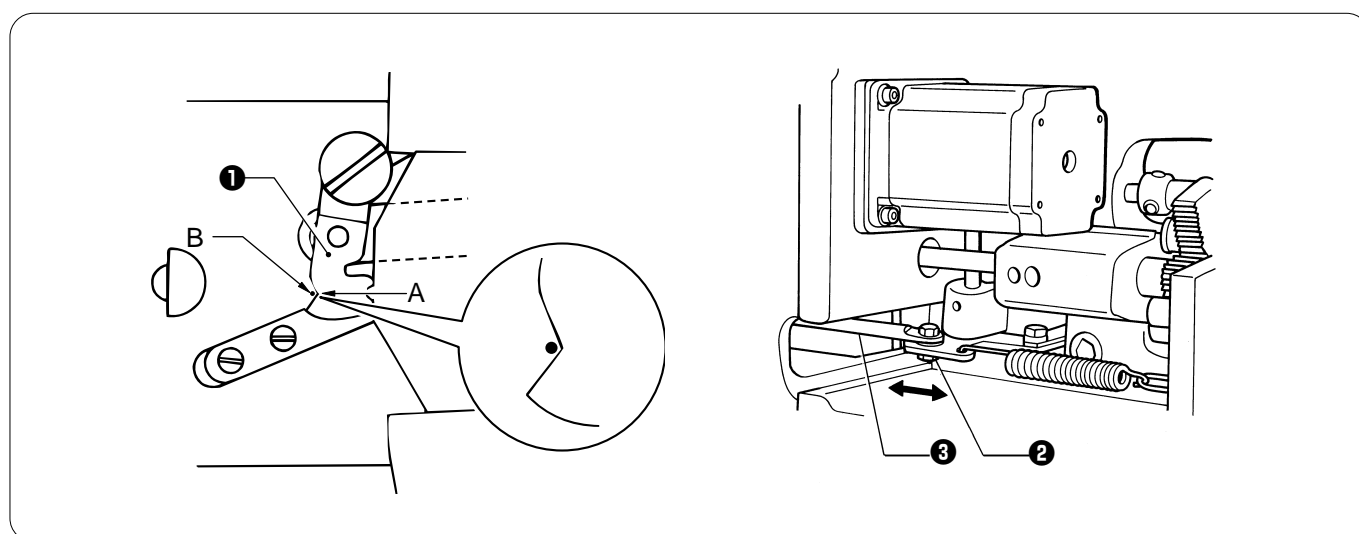

Loosen the nut **2** and move the connecting rod lever **3** to the left or right to adjust so that the V section A is aligned with the index mark B on the needle plate when the sewing machine is in the stopped position and the movable knife **1** is moved toward the index mark.

10. Adjustments

10-7-1. Replacing the movable knife and fixed knife

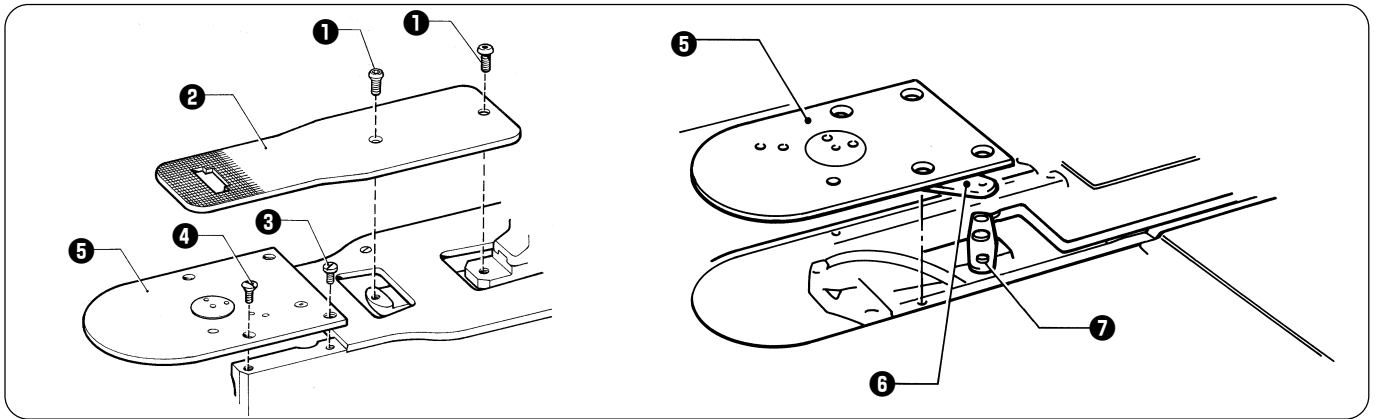

1. Open the large shuttle hook cover, remove the screw **1**, and then remove the feed plate **2**.
2. Remove the two screws **3** and the two screws **4**, and then remove the needle plate **5**.
3. Remove the thread trimmer connecting rod **6** from the connecting rod lever pin **7**.

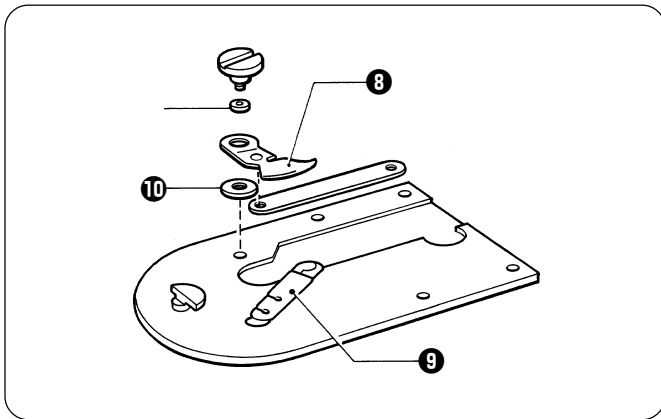

4. Remove the movable knife **8** and replace it with a new one. At this time, check that the movable knife **8** and the fixed knife **9** cut the thread cleanly. If necessary, adjust by using the appropriate movable knife washer **10** (supplied as accessories).

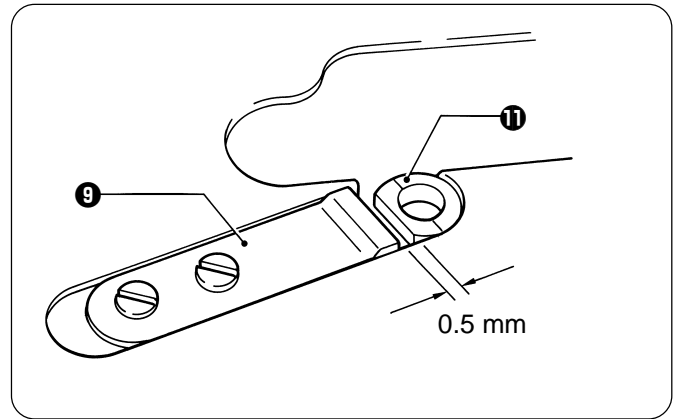

5. Install the fixed knife **9** at a distance of 0.5 mm from the needle hole plate **11**.
6. Place the thread trimming connecting rod **6** onto the connecting rod lever pin **7**, and then install to the needle plate **5**.

10-7-2. Adjusting the engagement of the movable knife and fixed knife

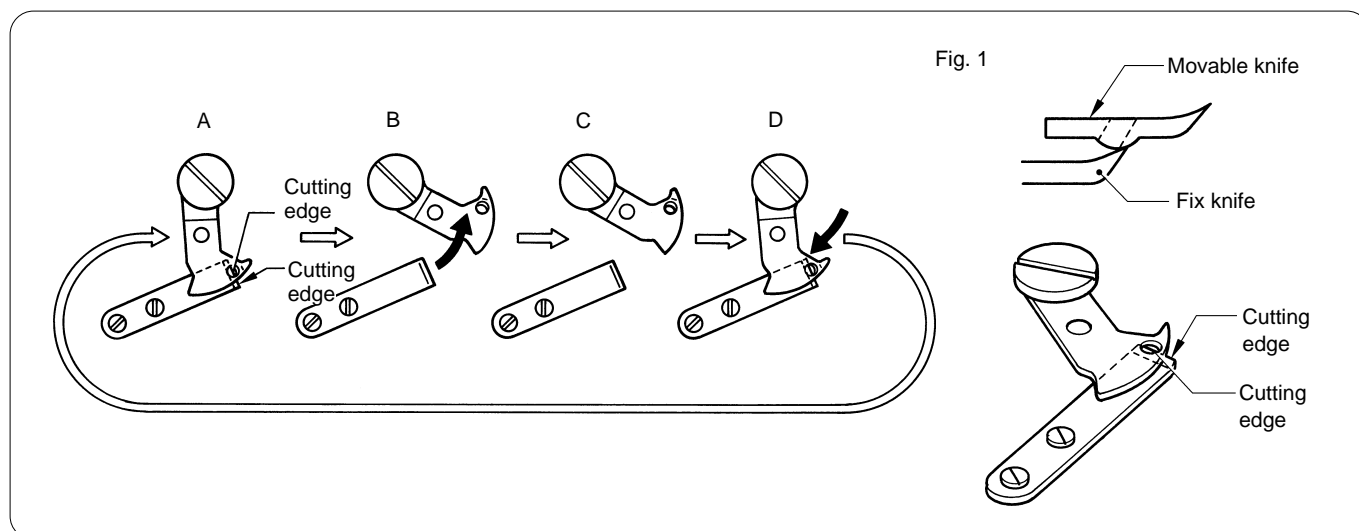

- A. After the movable knife and fixed knife are properly engaged, tighten the screw as shown in Fig.1.
- B. Turn the movable knife (in the direction of the arrow) while the screw is still tightened.
- C. Loosen the screw.
- D. Turn the movable knife (in the direction of the arrow) while the screw is still loosened.
- Repeat above steps A, B, C and D four or five times to maintain the cutting performance of the knife.

10-8 . Adjusting the button clamp lift amount

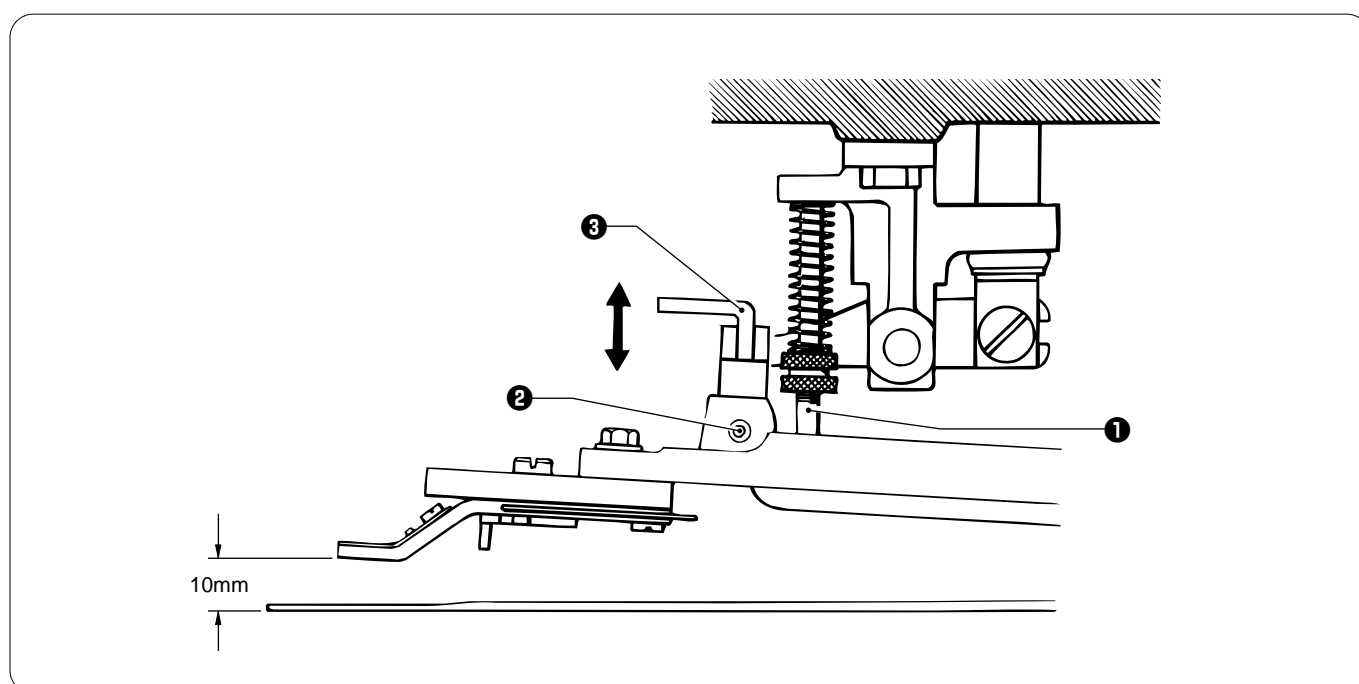

The button clamp lift amount is 10 mm from the top of the needle plate.

To adjust the button clamp lift amount, remove the button clamp presser spring ①, loosen the screw ② and adjust the button clamp holder hook ③ by moving it up and down.

* If movement is sluggish when the button clamp is being raised and lowered, it may not be possible to increase the button clamp lift amount.

* If the button clamp cannot be raised or lowered, error code [E-61], [E-63] will be displayed.

10. Adjustment

10-9. Adjusting the holding pressure

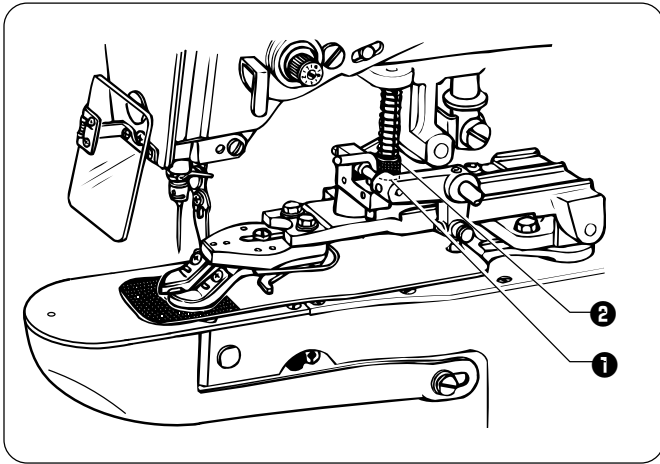

Loosen screw ❶ and turn adjustment screw ❷ so that clamp pressure is as light as possible but high enough so that the material will not slip when pulled lightly.

* If the clamp pressure is too high, the buttons may not be fed properly.

10-10. Adjusting the position of the button holder

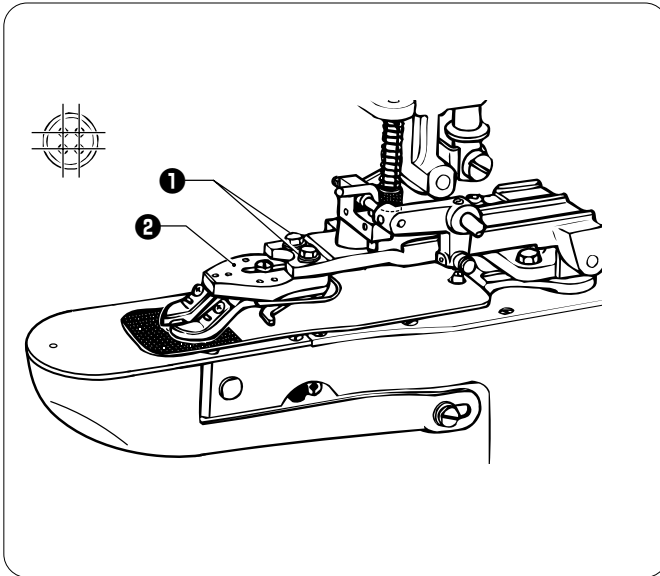

1. Loosen the two hexagonal bolts ❶ and adjust the button holder body ❷ by moving it.
2. Check that the needle will go through the button hole with no contact. (Refer to "6. CHECKING THE SEWING PATTERN".)

10-11. Adjusting the button clamp height

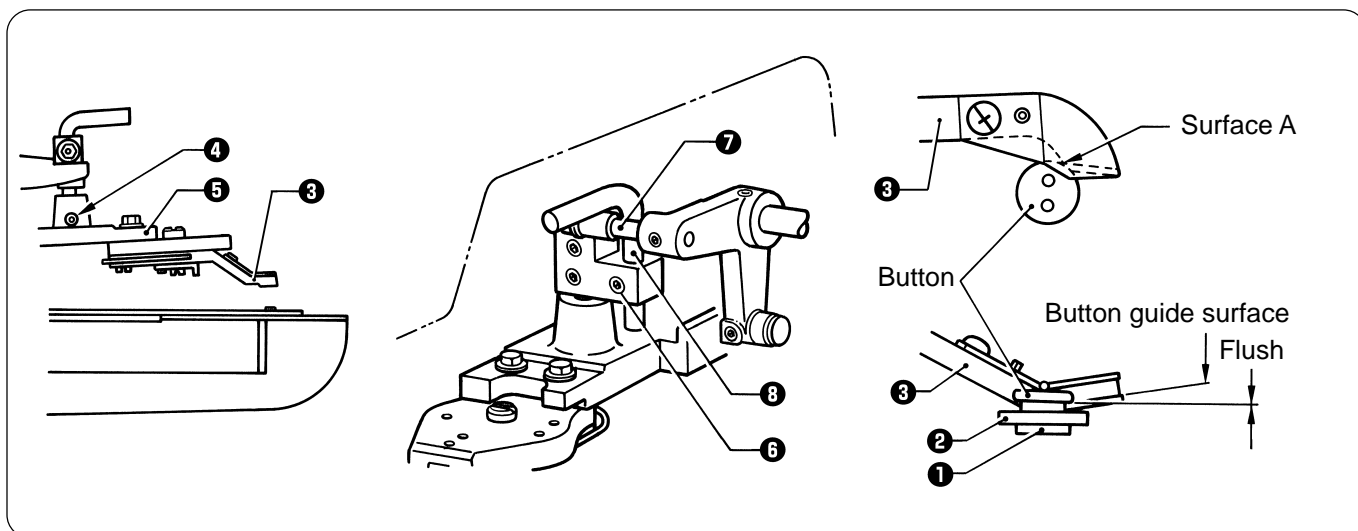

Adjustment

1. After turning on the power switch, turn AUTO 1 or AUTO 2 the feeder switch.
2. The button carrier will move slowly if the foot switch is turned on with the manual switch depressed.
The sewing machine will operate in inching mode while the manual switch is being pressed, and will stop when the manual switch is released.
3. Stop machine inching when button transport arm ① moves and the button is at button guide surface A.
4. Make sure that top of button carrier ② is flush with the button guide surface of button clamp ③.
If they are not properly aligned loosen screw ④ and move button clamp holder ⑤ up or down.
5. Loosen screw ⑥, set presser bar lifter hook A ⑦ against presser bar lifter roller arm ⑧, and tighten screw ⑥.
* Press the manual switch to return the button transport arm ① when the adjustment is completed.
6. Turn off the power to cancel inching operation.

10. Adjustment

10-12. Adjusting the needle up stop position

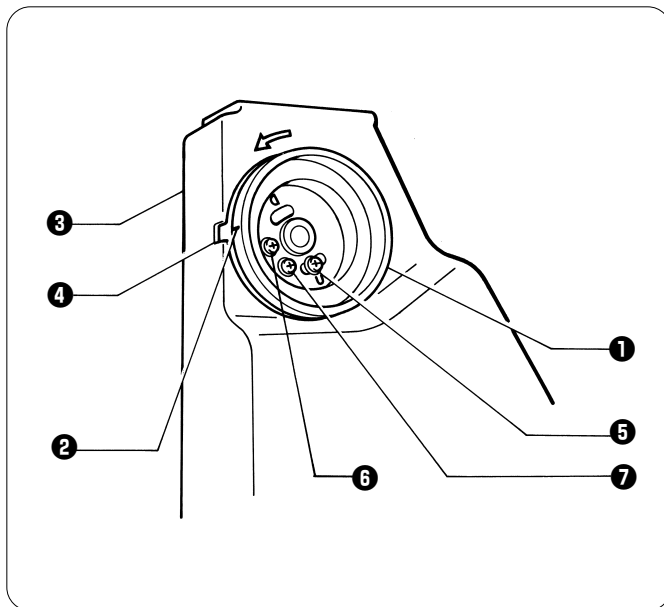

The needle up stop position is adjusted so that the index mark ② on the machine pulley ① is inside the mark ④ on the belt cover ③.

If adjustment is necessary, loosen the screw ⑤ at the "U" mark of the machine pulley ① and adjust the position of the machine pulley ①. The machine pulley ① stops later if it is turned clockwise, and it stops earlier if it is turned counterclockwise.

NOTE:

The screw ⑥ at the "D" mark is an adjusting screw for the needle down detection function and is adjusted to match the feed timing, so it should not be loosened.

The screw ⑦ is a screw for detecting the machine stop position, and should not be loosened.

* If the index mark ② is not inside the mark ④ when the sewing machine is started, error code [E-50] will be displayed. Turn the machine pulley to move the index mark ② to the correct position and then start the sewing machine.

10-13. Adjusting the thread wiper

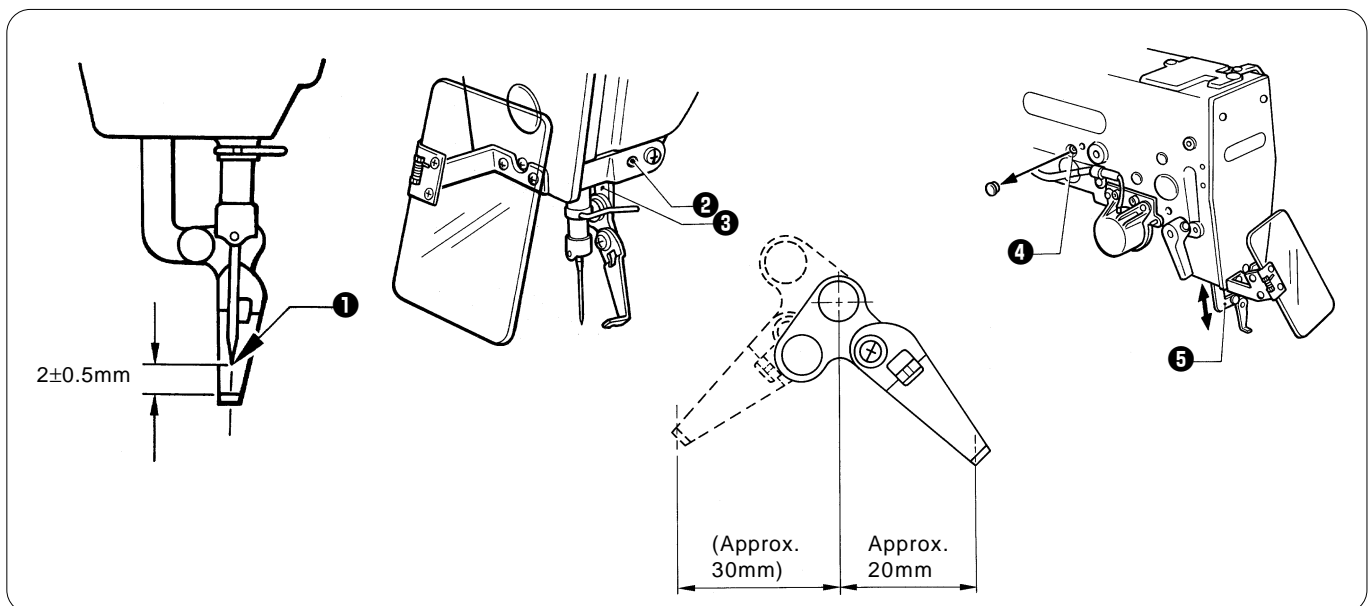

1. Loosen the set screw ② and move the wiper arm support ③ up or down to adjust so that the clearance between the top of the thread wiper and the needle point ① is 2 ± 0.5 mm when the thread wiper is aligned with the center of the needle.

* Before carrying out this adjustment, check that the needle bar is lowered 3.5 to 4 mm from the needle up stop position when the sewing machine stops.

2. Loosen the screw ④ and move the thread guide connecting plate ⑤ up or down so that the thread wiper is approximately 20 mm from the needle when it is at the standby position.

10-14. Adjusting the vibrating bowl

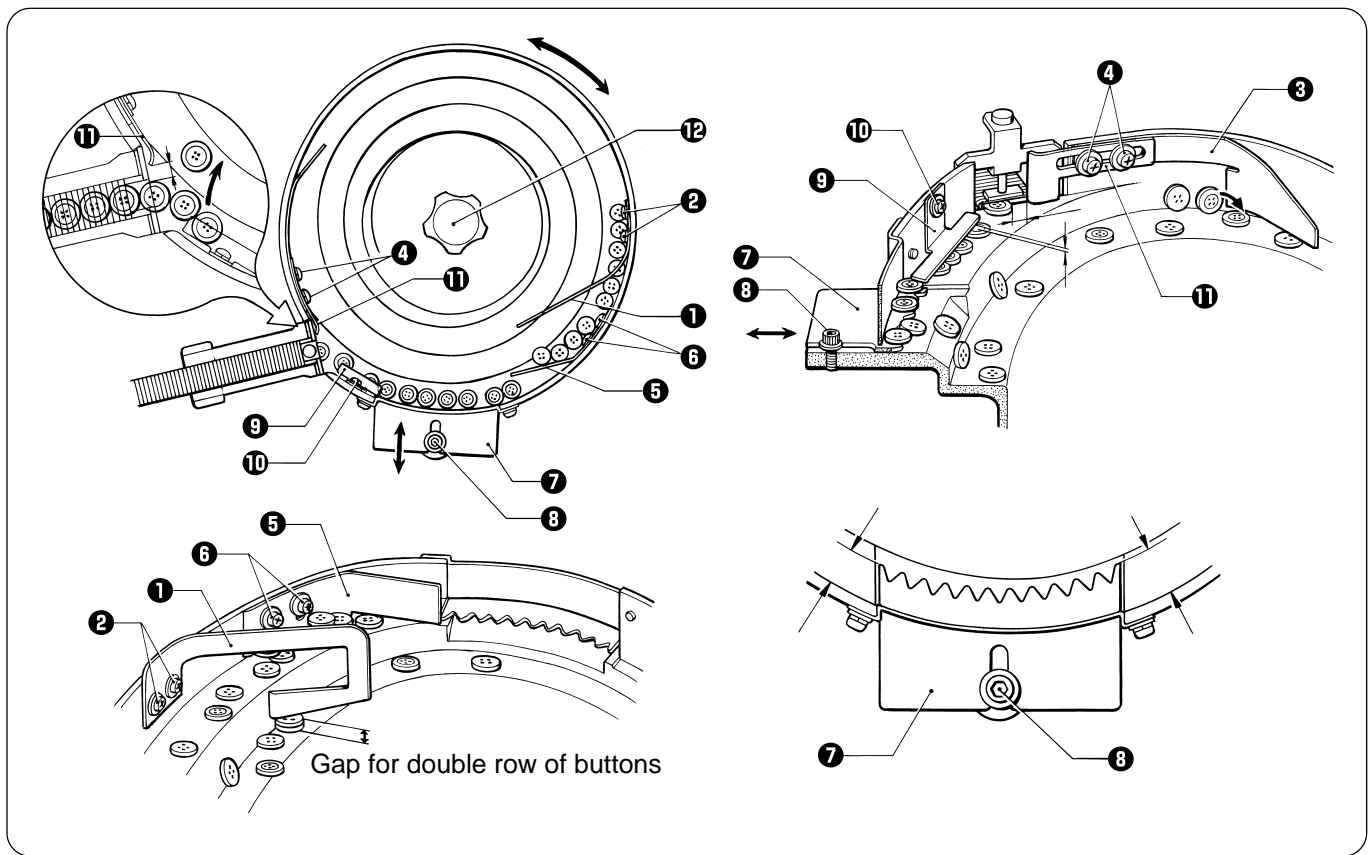

- The vibrating bowl arranges all of the buttons face up and feeds the buttons to the shooter.
- Be sure to readjust the vibrating bowl whenever the buttons are changed.

■ If buttons are not fed properly, check the following.

1. Loosen screw ② and adjust the gap between the bottom of arm B ① and the vibrating bowl so that two buttons can pass.
2. Loosen screw ④ and adjust the gap between the bottom of arm C ③ and the vibrating bowl so that one button can pass.
In addition, the arms should topple any standing buttons to assure a smoother flow.
3. Loosen screw ⑥ and adjust the gap between the bottom of arm A ⑤ and the vibrating bowl so that one button can pass.
4. Loosen bolt ⑧ and move selector plate ⑦ in or out so that the buttons are aligned face up.
5. Loosen screw ⑩ and adjust the gap between the bottom of height control arm ⑨ and the top of the buttons to approximately 0.7 mm.
6. Loosen screw ④ and adjust the button to button width adjustment arm ⑪ gap to approximately 2 mm so that the buttons are fed to the shooter.
7. If buttons become clogged at the entrance to the shooter, loosen screw ⑫ and turn it so that buttons do not clog at the shooter entrance.

10. Adjustment

10-15. Adjustment for excess buttons in the button shooter

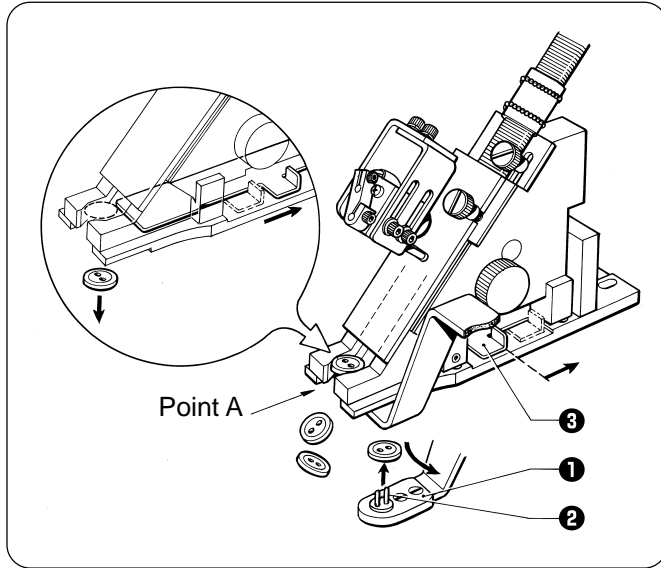

1. Turn the button carrier **1** by hand in the direction of the arrow, and remove any buttons from the button carrier pin **2**.
2. With the button carrier **1** in this position, pull lever **3** to remove any excess buttons from the shooter at point A.
3. Press the manual switch to feed a button to the button clamp.

10-16. Button replacement

10-16-1. Adjustment when the button diameter is changed

■ Slide base adjustment

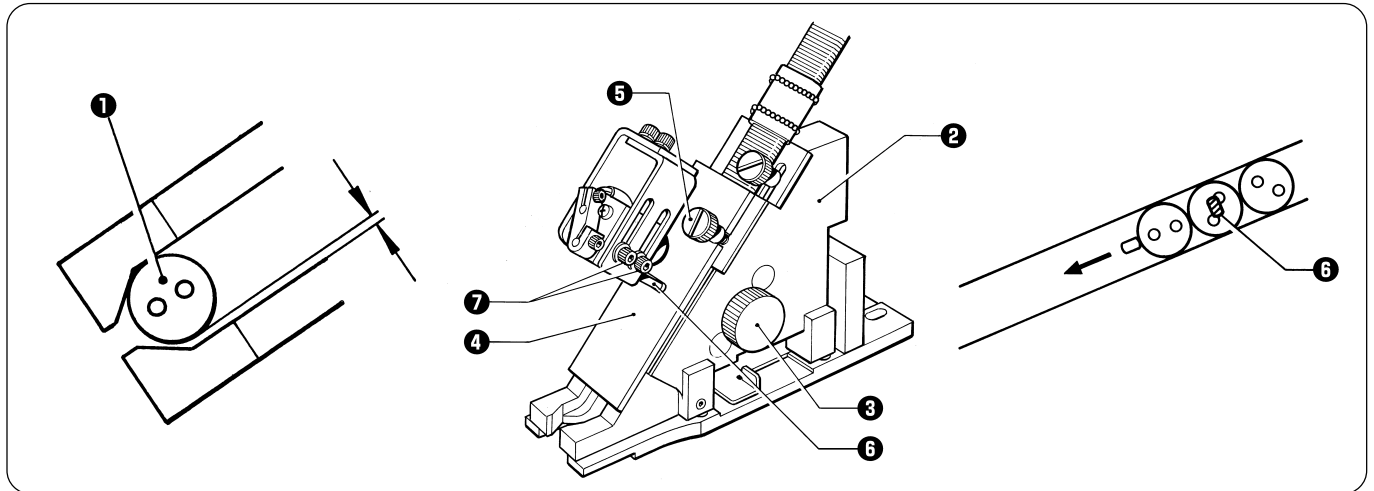

- Adjust the width of the slide base assembly **2** to the button width with slide base screw **3** so that the buttons **1** pass smoothly.
The bed slide base assembly **2** can be adjusted for button diameters of 9 to 22 mm.
Adjust so that the clearance between the buttons **1** and the edge of the slide base assembly **2** is 0.5-1.0 mm.
- There are 3 different button upper covers **4**. The cover for standard button sizes of 9 to 13 mm is factory installed.
To attach buttons from 13 to 22 mm in diameter, loosen screw **5** and replace cover **4** (nonstandard accessories).
- When the button diameter is changed, adjust button stopper A **6** with the adjusting screws **7**. Adjust until stopper A **6** slides into the groove of the upper cover **4** and comes into contact with the second button (position A).

■ Button clamp adjustment

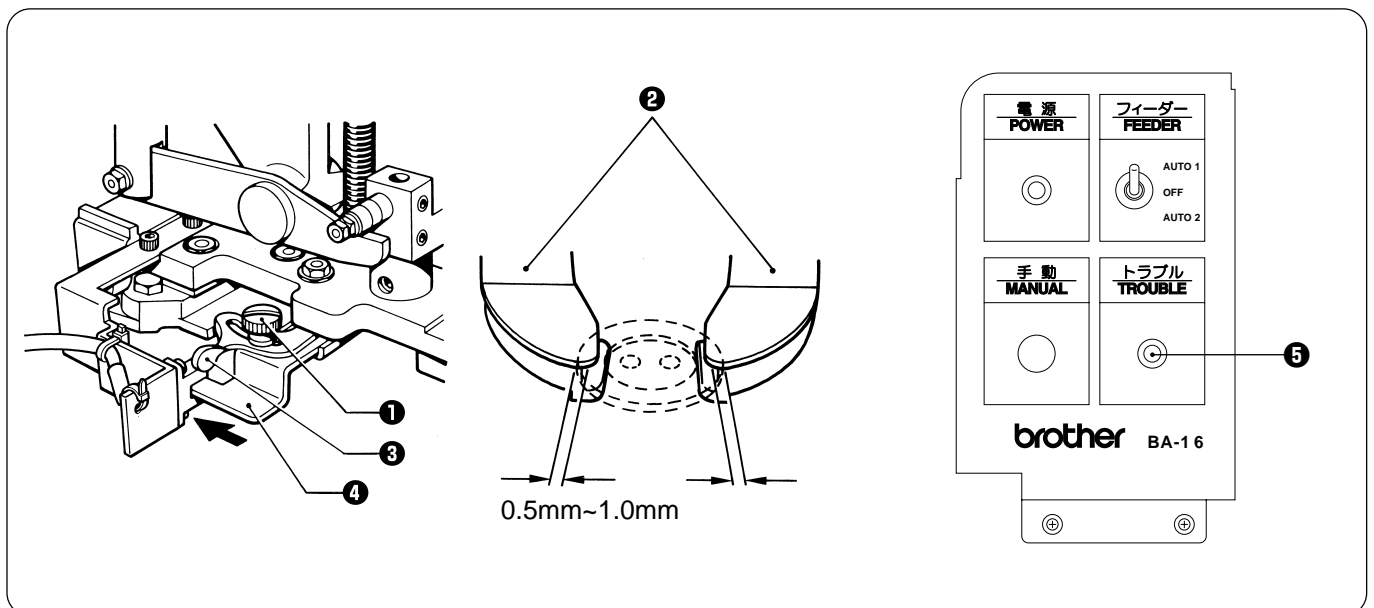

- Loosen step screw **1** and insert a button into the button clamp **2**.
- Lightly tighten step screw **1**, and remove the button.
- Close the button clamp **2** opening 0.5 to 1.0 mm using the plate **3**.
- Firmly tighten step screw **1**.
- After the button is inserted, push the lever **4** slightly in the direction of the arrow to check that the trouble indicator **5** does not blink.
* If the indicator blinks, move slightly and narrow the button clamp **2** opening (mentioned in 3. above).

10. Adjustment

10-16-2. Adjustment when the button thickness changes

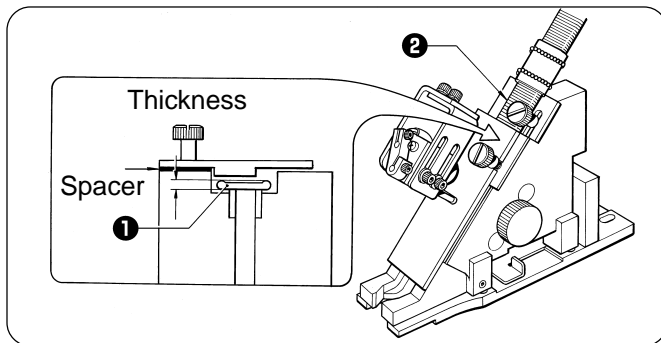

1. Check to be sure that buttons **1** are being smoothly sent to the shooter **2**. If the buttons are not fed smoothly, replace the shooter.
2. Install accessory spacers (0.4 mm, 0.8 mm,) as required by the button thickness.
3. Check to be sure that buttons are being securely grasped by the button clamp.
* If no spacers are used, button thicknesses from 1.8 to 2.2 mm can be used.

10-16-3. If button hole arrangements differ

(Used to change from a two hole button to a four hole button, or from a four hole button to a two hole button.)

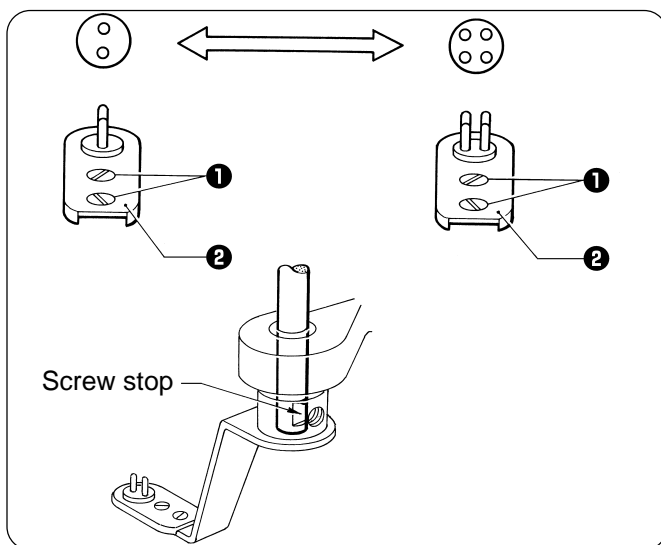

- Loosen screw **1** and replace the button carrier **2**.
- * Adjust the button carrier. (Next page)
 - * Adjust the feeder position. (Next page)
 - * Adjust the needle position. (See p.31.)

10-16-4. Adjusting the button carrier plate

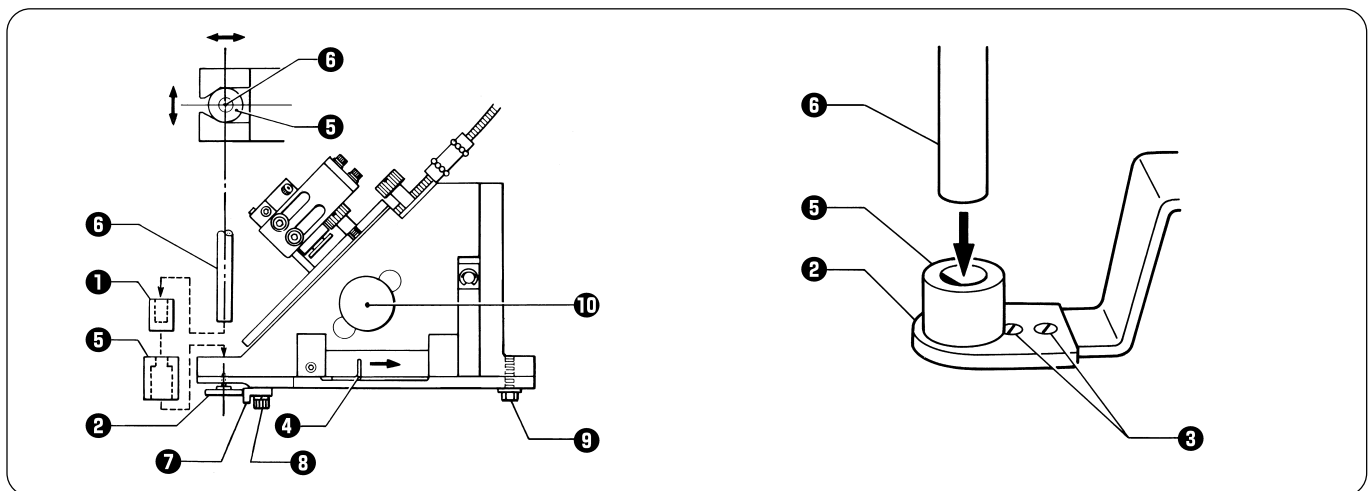

1. Remove the button clamp **1**.
2. Turn the slide base screw **10** to widen the slide base width, then put the gauge **5** on the button carrier plate. Turn the slide base screw **10** and tighten the gauge at the bottom of the slide base.
* At this time, leave the screw **9** and the screw **8** of the stopper **7** loosened.
3. Adjust the slide base so that the shaft **6** fits in the hole of the gauge **5**. Then tighten the screw **9**.
4. With the button carrier plate **2** touching the stopper **7**, tighten the screw **8**.
5. Remove the gauge **5** and insert the shaft **6** into the button clamp **1**.
* This adjustment has already been made at shipping. Therefore, during regular replacement of the button carrier plate, only the replacement procedure described on the this page is necessary.

10-16-5. Adjusting the feeder position adjustment

* For all programs, the shunting point for the sewing home position point is set to the first stitch position. As long as the button size is not changed, it is not necessary to change the program in order to adjust the feeder position.

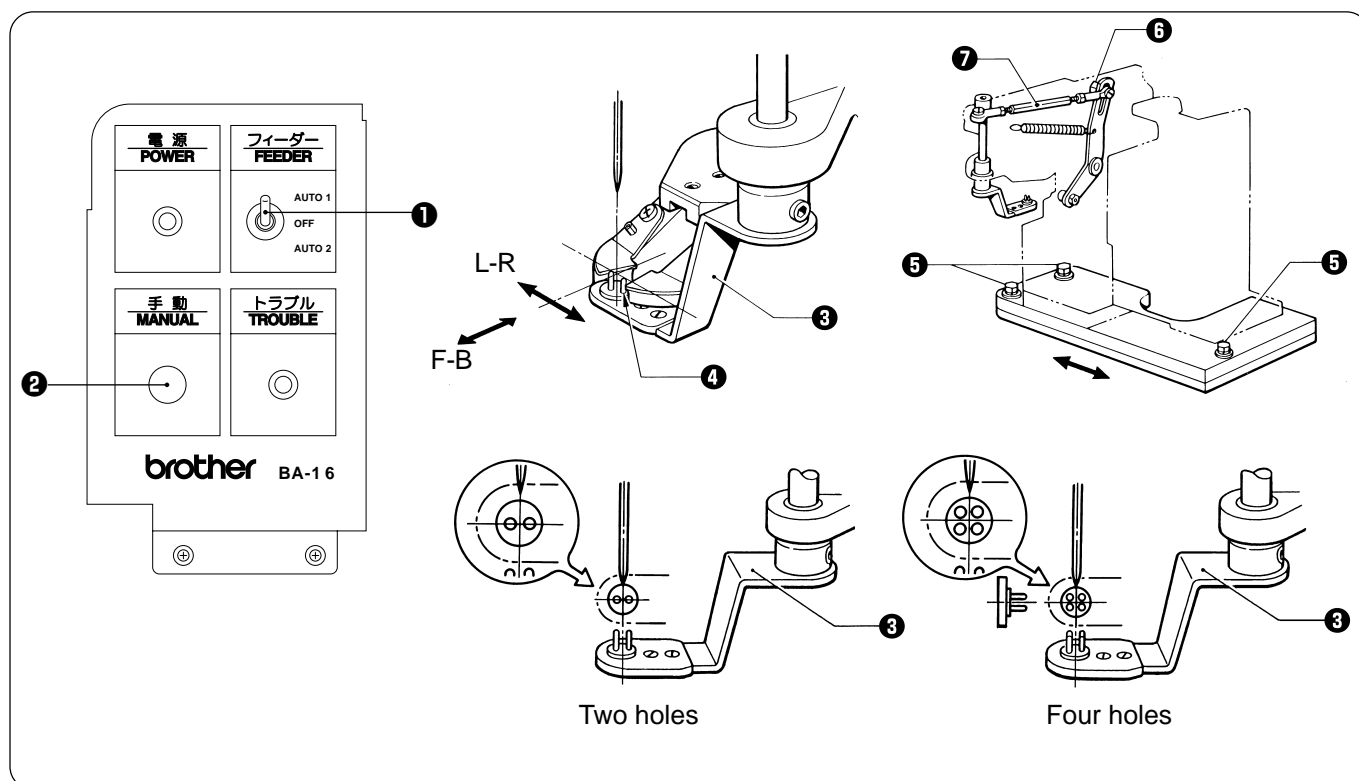

1. Turn on the power switch.
2. Check whether or not the feeder switch ① is AUTO 1.
3. Press and hold manual switch ② and turn the foot switch on. The machine will begin to operate.
 - * At this time, the machine head will be prevented from operating, and error code "E-C3" will be displayed. The buzzer will stop sounding when the RESET switch is pressed, but the error code will continue to be displayed, and so the machine head will still be prevented from operating.
 - * The sewing machine will operate in inching mode while the manual switch ② is being pressed, and will stop when the manual switch ② is released.
4. Continue pressing manual switch ② and move button transport arm ③ all the way forward to the needle.
 - * Assist the button clamp by lifting up.
5. While pushing the button clamp upward, place a button into the button clamp.
6. Check that the button carrier pin is aligned with the hole in the button when the button transport arm ③ is as far forward as it can go (to the needle side).
 - * The alignment is correct if the pin goes into the hole in the button the pin when the button clamp is moved up and down.
7. If the button carrier pin and hole are not aligned in the left-right direction, loosen the bolt ⑤ and move the entire button feeder assembly to the right or left to adjust.
 - If they are not aligned in the forward-back direction, loosen the nut ⑥, and move the connecting shaft ⑦ up or down to move the button transport arm ③ forward or back.
 - After adjustment, press manual switch ② and return button transport arm ③.
 - * If the button transport arm ③ is not at the home position, error code [E61] may be displayed when the power is turned off and back on again. Be sure to return the button transport arm ③ to the home position. (Do not turn off the power while doing this.)
 - * When adjustment is completed, turn the pulley by hand to make sure the needle does not strike the button (needle position adjustment).
8. After adjusting, turn off the power switch and then turn it back on again.
 - * Wait approximately 5 seconds after turning off the power switch before turning it back on again.

10. Adjustment

10-16-6. Adjusting the needle location

Adjustment is required whenever the button carrier is replaced.
Make sure the needle is not bent.

■ Horizontal feed position

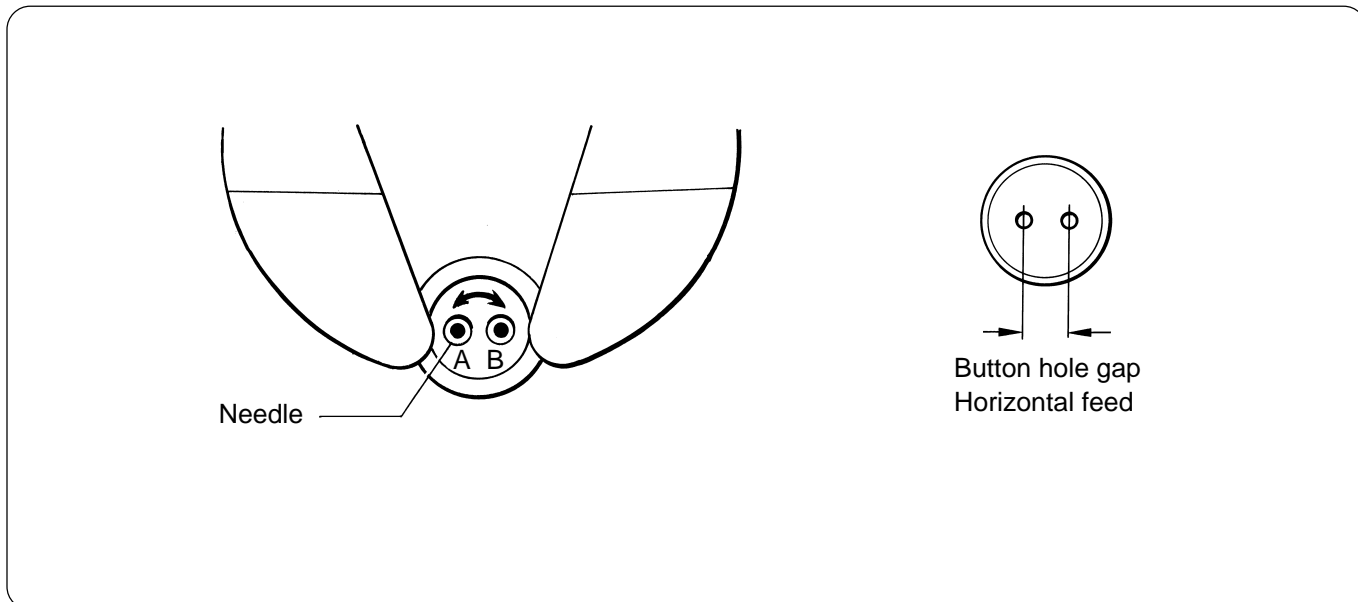

1. Set the X scale so that the holes A and B in the button are aligned with the point of the needle. (Refer to “Setting the X-scale and Y-scale” on page 45.)
2. Check the positions of the button holes. (Refer to “Checking the sewing pattern” on page 26.)

■ Vertical feed position

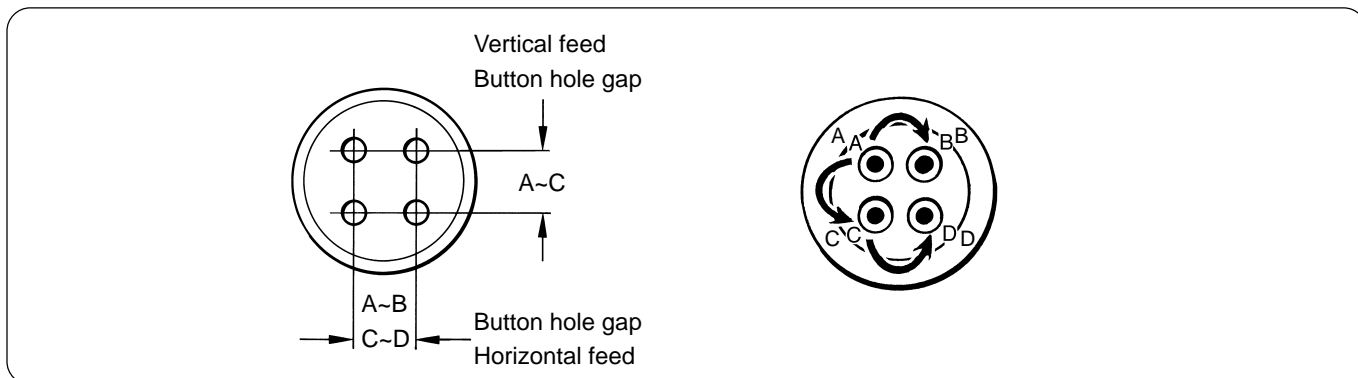

1. Set the Y scale so that the holes A and C in the button are aligned with the point of the needle. (Refer to “Setting the X-scale and Y-scale” on page 45.)
2. Check the positions of the button holes. (Refer to “Checking the sewing pattern” on page 26.)

10-17. Replacement the V-belt

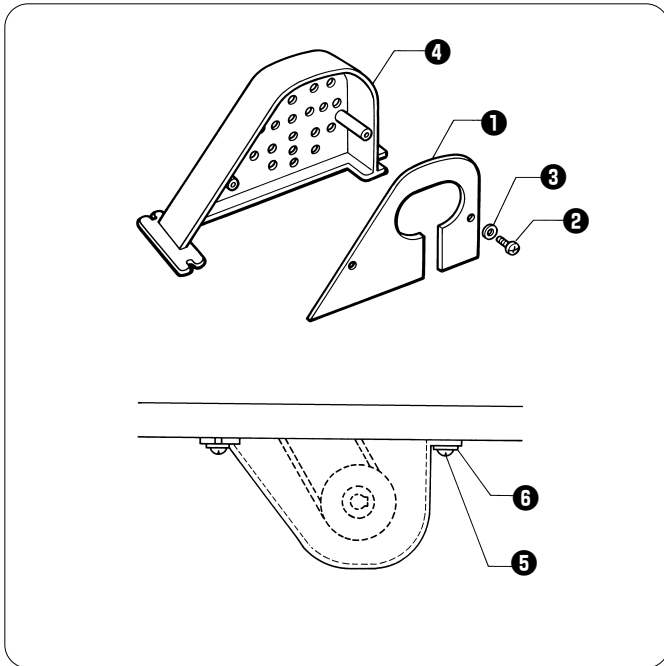

1. Then remove the belt cover.
(Refer to "Tilting back the machine head" on page 35).
2. Remove the motor back cover ① with the screws ② and the flat washers ③.
3. Remove the wood screw ⑤ and washers ⑥ securing the motor cover ④, and remove the table.

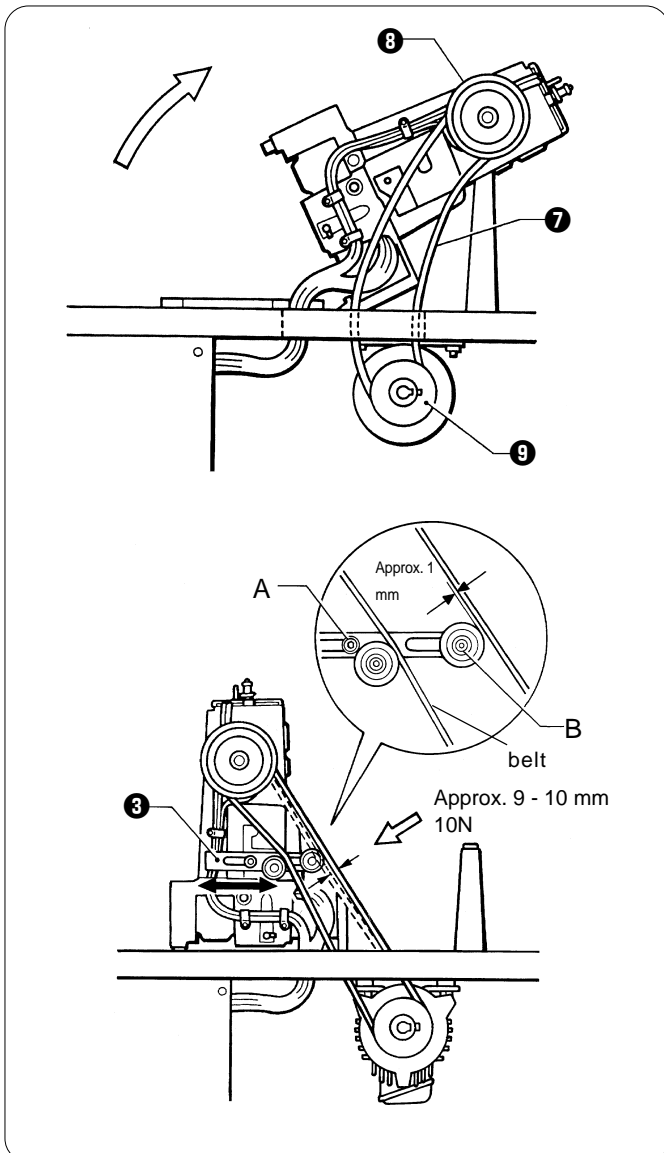

4. Gently tilt back the machine head, and then place the V-belt ⑦ remove the V grooves on the machine head pulley ⑧ and the motor pulley ⑨.

NOTE:

After tilting back the machine head, do not push the face plate side or the pulley side from above.

5. Gently return the machine head to its original position replace V-belt.
* Be careful not to clamp the cords at this time.

6. Adjust the belt tension by moving the tension pulley assembly to the right and left so that there is 9-10 mm of deflection in the V-belt ① when it is gently pushed in the middle with a force of approximately 10 N. After adjusting, tighten the bolt A to secure the left pulley assembly.

7. Move the right tension pulley so that there is a gap of about 1 mm between it and the V-belt ①, and then tighten the bolt B to secure the right pulley assembly.

8. After adjustment, install the belt cover and the motor cover.

10. Adjustment

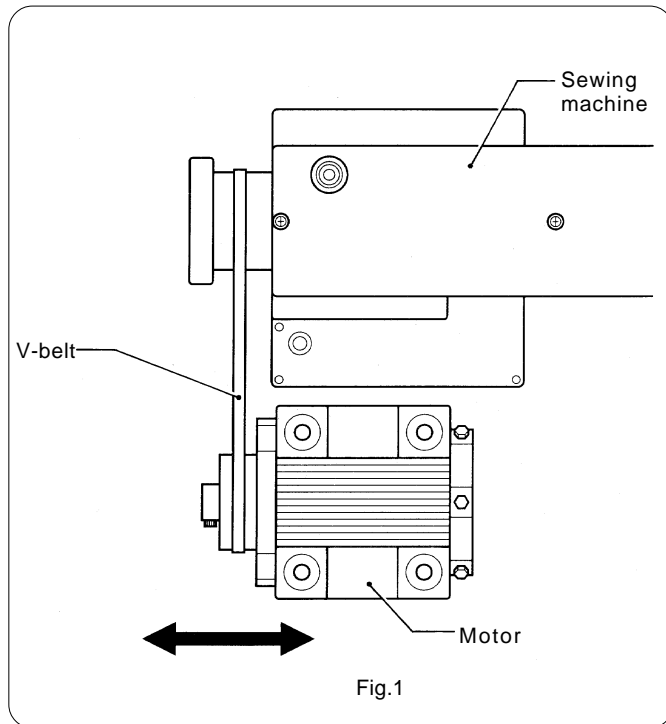

NOTE:

Use brother specified V-belt (belt, VM).

The V-belt may stretch slightly when it is first used, so adjust the belt tension after about 3,000 cycles of use.

When above belt tension is weak, this will be cause of following problems;

- Noise and vibration become large.
- Needle up stop position becomes unstable.
- Error message [E-5] is displayed.

Check that the motor is positioned so that the V-belt is straight. (Fig.1)

10-18. Checking the input sensor and DIP switch input

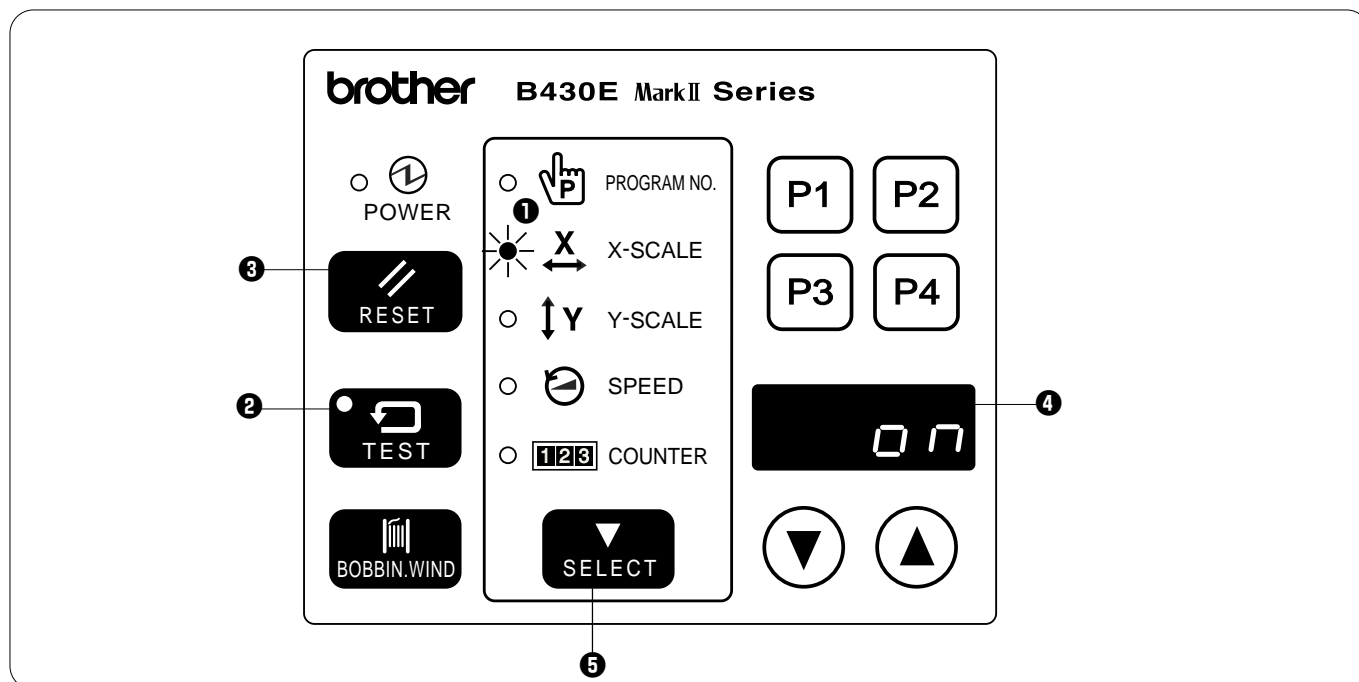

1. When the X-SCALE indicator ① is illuminated and the RESET switch ③ is pressed while the TEST switch ② is being pressed, the state of the X home position signal will appear on the display window ④.
- When sensor is ON
 - When sensor is OFF



2. Each time the SELECT switch ⑤ is pressed, a different indicator will illuminate and the operating condition for the corresponding item will appear on the display window ④
- When X-SCALE indicator is illuminated X home position sensor (ON when home position detected)
 - When Y-SCALE indicator is illuminated Y home position sensor (ON when home position detected)
 - When SPEED indicator is illuminated Synchronizer (* 1)
 - When COUNTER indicator is illuminated Presser sensor (ON when presser is lowered)
- *1 The synchronizer display simultaneously displays the needle up signal (3rd digit), the 24-section signal (2nd digit) and the needle down signal (1st digit).

[H L L] "H" when the sensor is on, and "L" when the sensor is off

↑ Needle down signal

↑ 24-section signal

↑ Needle up signal

If the DIP switches at the side of the operation panel are changed at this time, the number of the DIP switch which was changed will be displayed in the 4th digit position of the display window ④ for about one second.

NOTE:

The DIP switch can be changed at this time without turning off the power so that you can check the DIP switch input. However, you should normally always turn off the power when changing DIP switch settings.

3. Press the TEST switch ② again to return the display to the normal condition.

10. Adjustment

10-19. Checking the input voltage

Specifications	Display	Notes
200V	[090 - 110]	"100" is displayed when the input voltage is 200 V.
220V	[100 - 120]	
230V	[105 - 125]	
100V 380V 400V 415V	[100 - 120]	"110" is displayed when the input voltage is 100V (for 100-V spece.), 380V (for 380-V spece.), 400V (for 400-V spece.) or 415V (for 415-V spece.).

1. Turn on the power switch.
2. Press the SELECT switch ① until the Y-SCALE indicator ② illuminates.
3. While pressing the TEST switch ③, press the RESET switch ④.
4. If the input voltage is normal, the input voltage conditions will be shown in the display window ⑤ as indicated in the table above.
5. Press the TEST switch ③ again to return the display to the normal condition.

10-20. Moving stitch patterns

- Programs which have already been programmed can be moved up, down and to the left and right. (However, such patterns will be reset if the power supply is turned off or the program number is changed.)
- The feed position can be set to the any position desired.

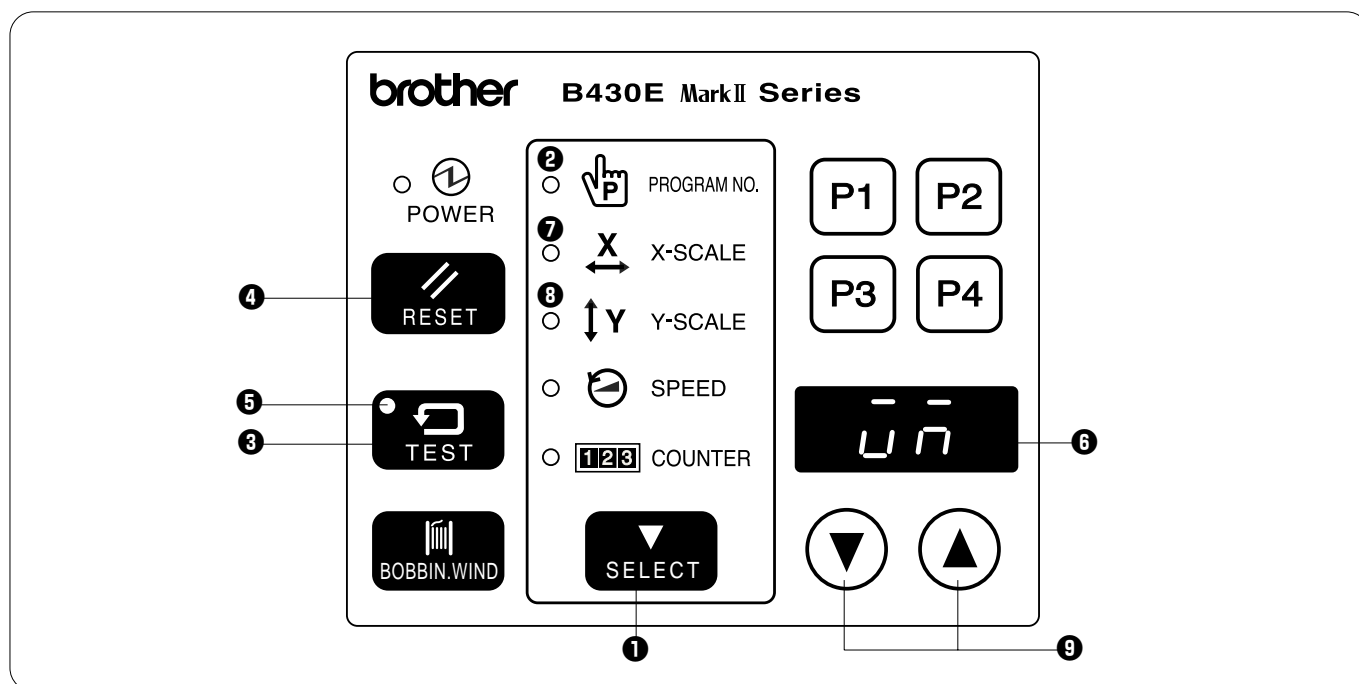

1. Select the program number, and then press the start switch once to move the feed mechanism to the sewing start position.
2. Press the SELECT switch **1** until the PROGRAM NO. indicator **2** illuminates.
3. While pressing the TEST switch **3**, press the RESET switch **4**.
 - * The TEST indicator **5** will illuminate and < UN > will appear in the display window **6**.
4. Press the SELECT switch **1** so that either the X-SCALE indicator **7** or Y-SCALE indicator **8** illuminates.
5. Press the DISPLAY SET switches **9** to move the feed mechanism one pulse at a time.
 - If the DISPLAY SET (▲) switch is pressed while the X-SCALE indicator is illuminated, the feed mechanism will move to the left.
 - If the DISPLAY SET (▼) switch is pressed while the X-SCALE indicator is illuminated, the feed mechanism will move to the right.
 - If the DISPLAY SET (▲) switch is pressed while the Y-SCALE indicator is illuminated, the feed mechanism will move down.
 - If the DISPLAY SET (▼) switch is pressed while the Y-SCALE indicator is illuminated, the feed mechanism will move up.
6. When the TEST switch **3** is pressed after the above fine adjustments have been made, the TEST indicator **5** and display window **6** will both switch off and movement of the stitch pattern will be completed.

NOTE:

When moving the stitch pattern, take the whole of the pattern area into consideration so that no parts extend outside the sewing area when the pattern is sewn.

- * If you would like to set the feed position to a desired position, carry out steps 2. to 6. above while the display window **6** is flashing. The stitch pattern will not be moved at this time.

11.Using the counters

11-1 . Using the bobbin thread counter

If you use the bobbin thread counter to set the number of articles which can be sewn with the amount of bobbin thread available, you can stop the bobbin thread running out in the middle of sewing a pattern.

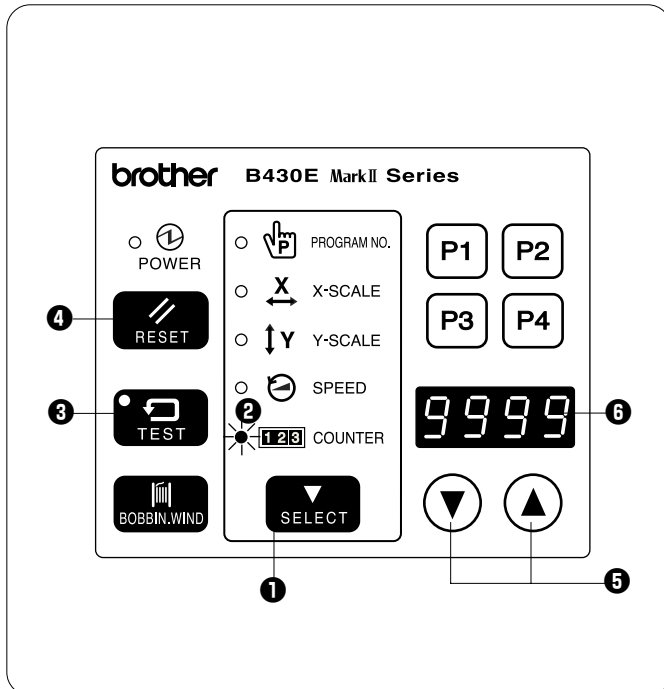

1. Press the SELECT switch **1** until the COUNTER indicator **2** illuminates.
2. While pressing the TEST switch **3**, press the RESET switch **4**.
 - * The COUNTER indicator **2** will flash and the counter will switch to bobbin thread counter setting mode.
3. Press the DISPLAY SET switches **5** to set the number of articles to be sewn.
 - The bobbin thread counter can be set to sew a number of articles from one (“0001”) through to 9999 (“9999”).
 - If the bobbin thread counter is set to “0000”, sewing is carried out without the number of articles sewn being counted.
 - If you press the RESET switch **4** while setting the bobbin thread counter, the setting will return to “0000”.
4. Press the TEST switch **3**.
 - * The number displayed in the display window **6** will then be stored as the bobbin thread counter setting.

5. Each time the sewing of a single article is completed, the number being displayed in the display window **6** will become smaller. When the number of articles set by the bobbin thread counter have all been sewn, “0000” will be displayed in the display window **6**, and an alarm will start sounding continuously.
 - * The sewing machine will not operate during this time, even if the foot switch is depressed.
6. Replace the bobbin, and then press the RESET switch **4**.
 - * The alarm will then stop sounding, and the number which was set in step 3. above will be re-displayed in the display window **6**.

11-2 .Using the production counter

The production counter can be displayed in the display window **6** separately from the bobbin thread counter.

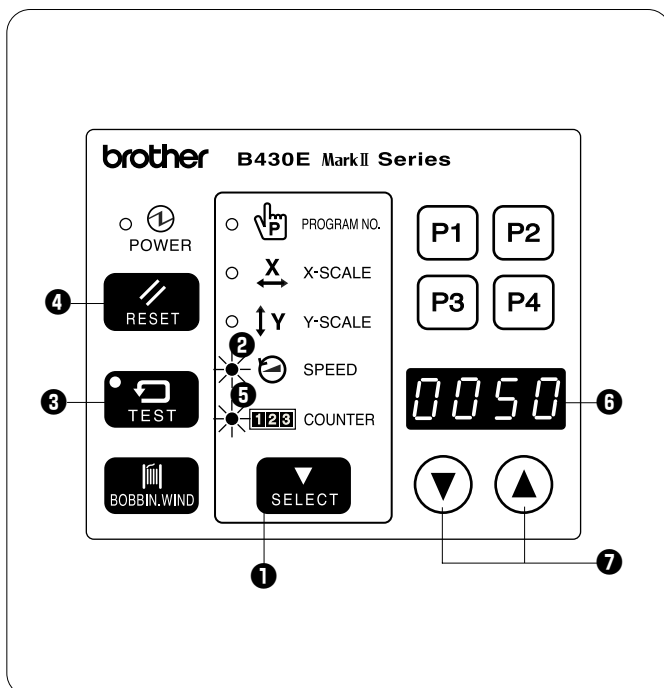

1. Press the SELECT switch **1** until the SPEED indicator **2** illuminates.
2. While pressing the TEST switch **3**, press the RESET switch **4**.
 - * The COUNTER indicator **5** and the SPEED indicator **2** will illuminate, and the production counter will be displayed in the display window **6**.
 - Press the RESET switch **4** to reset the production counter to “0000”.
 - You can also press the DISPLAY SET switches **7** to set the production counter to the desired value.
3. When the foot switch is depressed, the sewing machine will start sewing.
4. If you press the TEST switch **3** or the SELECT switch **1**, the display will return to showing the bobbin thread counter.

12.Using user programs

User program ...

It can store sixteen different programs which can include details such as the program number, X scale, Y scale and sewing speed. If you are sewing certain patterns over and over again, it is useful to record the settings for these patterns into a user program.

Recording a user program

1. Turn off the power switch and then set DIP switch A-3 of the DIP switches ① to ON.

2. Turn on the power switch.
While pressing the TEST switch ②, press the SELECT switch ③.

* All of the menu indicators (④ to ⑧) will illuminate and the mode will switch to recording mode.

* In addition, "PP 1" will appear in the display window ⑨ to indicate that user program No.1 is being recorded. (Once recording of No.1 is completed, No.2 will be displayed; once No.2 is completed, No.3 will be displayed. Thus the next unrecorded program letter is always displayed.)

3. Press the SELECT switch ③.

* The PROGRAM NO. indicator ④ will illuminate.

4. Press the DISPLAY SET switches ⑩ to select the number for the program that you would like to record.

5. Press the SELECT switch ③. * The X-SCALE indicator ⑤ will illuminate.

6. Press the DISPLAY SET switches ⑩ to select the X scale setting that you would like to record.

7. Press the SELECT switch ③. * The Y-SCALE indicator ⑥ will illuminate.

8. Press the DISPLAY SET switches ⑩ to select the Y scale setting that you would like to record.

9. Press the SELECT switch ③. * The SPEED indicator ⑦ will illuminate.

10. Press the DISPLAY SET switches ⑩ to select the speed setting that you would like to record.

11. Press the SELECT switch ③. * This completes the recording of user program No.1.

* "PP 2" will then appear in the display window ⑨, to indicate that user program No.2 is now being recorded.
Repeat steps 3. through to 11. to record further programs as desired.

12. Press the TEST switch ②. This completes the recording.

* The menu indicators (④ to ⑧) will all illuminate and "p1" will appear in the display to indicate that user program No.1 is currently selected.

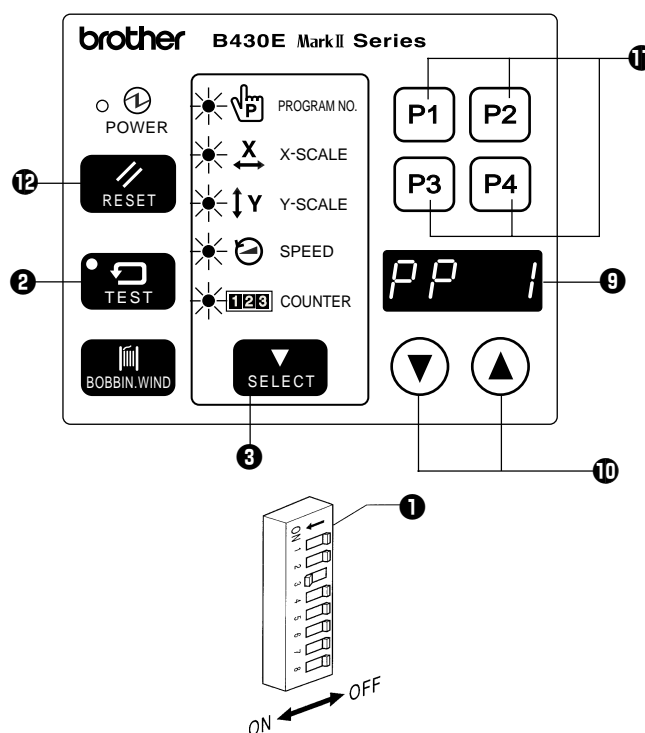

12. Using user programs

Using a user program

1. Press the DISPLAY SET switches **10** to select the speed program number for the user program that you would like to use.

*The user program numbers P1 to P4 can also be selected using the user program switches **11**.



2. Depress the foot switch to the second step.



3. Check the sewing pattern (see P.20), and then sew the pattern selected.

Clearing the user programs

1. Switch the machine to recording mode by the procedure in steps 2. of recording a user program.



2. Use the DISPLAY SET switches **10** to specify the user program number which is to be cleared of data.



3. Press the RESET switch **12**.

* The buzzer will sound and the user program with the number selected will be cleared.

* If you press and hold the RESET switch **12** until after the buzzer has sounded twice, all user programs will be cleared.

NOTE:

If data has been recorded in user programs P1, P2, P3 and P4 and you then clear the data in user program P2, the contents of P3 will be transferred to P2, and the contents of P4 will be transferred to P3.

13. Using the cycle sewing function

What is the cycle sewing function?

The cycle sewing function lets you program up to four patterns for cycle sewing of patterns in a predetermined order.

Recording a cycle sewing program

1. Set DIP switch ①-3 to ON, and then record the patterns which you would like to use for cycle sewing. (Refer to "12-4. Using user programs".)

* Cycle sewing cannot be performed using patterns (P1 to P16) which have not had a user program assigned.

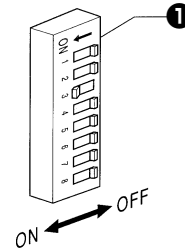

2. Set the memo-03 switch to ON. (Refer to page 45 for how to do this.)

3. While pressing the TEST switch ②, press the SELECT switch ③.

* All of the menu indicators (④ to ⑧) will illuminate and the mode will switch to recording mode.

4. Press the P1 switch ⑨.

• "Pc 1" will appear in the display window ⑩ to indicate that cycle sewing program No. 1 is being recorded.

* Programs P2, P3 and P4 switches can also be used for programming.

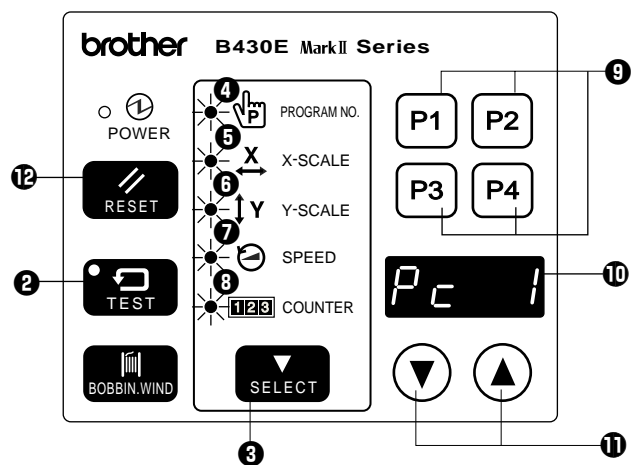

5. Press the SELECT switch ③. *The PROGRAM No. indicator ④ will illuminate and "1- -" will appear in the display window ⑩.

6. Press the DISPLAY SET switches ⑪ to select the number for the user program that you would like to record.

7. Press the SELECT switch ③. *"2- -" will appear in the display window ⑩.

8. Press the DISPLAY SET switches ⑪ to select the number for the user program that you would like to record.

9. Repeat steps 5. and 6. to record all programs which you would like to include for cycle sewing.

* After "9- -" is displayed, "A- -", "b- -", "c- -", "d- -", "E- -" and "F- -" will be displayed in that order so that up to the 15th pattern can be recorded.

* If you would like to return to a previous number during the recording procedure, press the P1 switch so that "Pc 1" is displayed, and then return to step 4.

10. Press the TEST switch ②.

• This completes the setting of cycle sewing program No. 1.

* The menu indicators (④ to ⑧) will all illuminate and "c1-1" will appear in the display window ⑩ to indicate that the cycle sewing program No.1 is currently selected.

13. Using the cycle sewing function

Using a cycle sewing program

1. When "c1-1" is flashing in the display window **10**, press the foot switch to the second step.



2. Start sewing.



3. "c1-1", "c1-2", "c1-3" are sewn in order for each article, and when the last-recorded pattern has been sewn, the display returns to "c1-1".

* If you press one of the DISPLAY SET switches **11** when "c1-**" is displayed, you can return to the previous stitch pattern or skip a stitch pattern.

* If you press the SELECT switch **9** when "c1-**" is displayed, you can check the contents of the recorded user program.

Clearing a cycle sewing program

1. Switch the machine to recording mode by the procedure in step 3. of recording a user program.



2. Use one of the P* switches (user program switches) to specify which cycle sewing program to clear.

* Press the P1 switch **9** if you would like to clear cycle sewing program No. 1. ("Pc 1" will be displayed.)



3. Press the RESET switch **12**.

* The recorded contents of the specified cycle sewing program will then be cleared.

* If you press and hold the RESET switch **12** until after the buzzer has sounded twice, all cycle sewing programs will be cleared.

NOTE:

If you clear a user program after any cycle sewing programs have been recorded, all recorded cycle sewing programs will also be cleared.

14. Changing functions using the DIP switches

14-1. Operation panel DIP switches

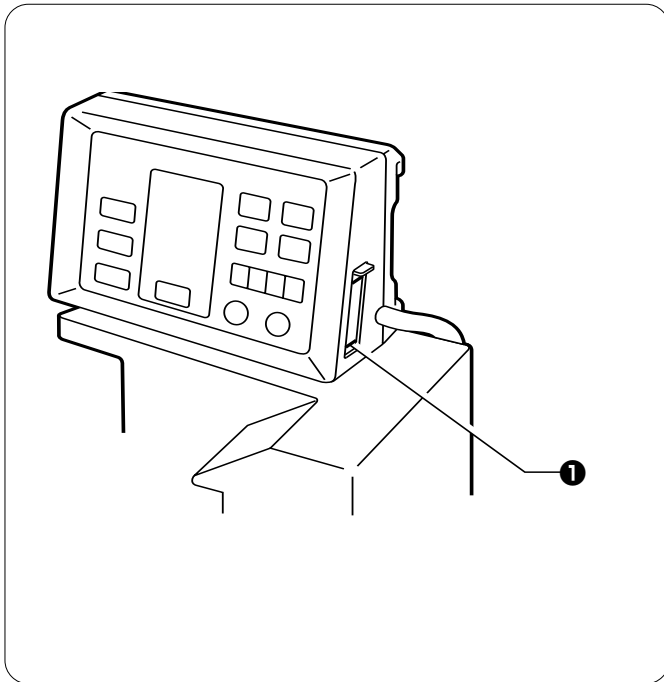

The operation panel DIP switches ❶ are used to change functions which might need to be changed depending on the sewing conditions.

NOTE:

Always turn off the power before setting the DIP switches.

The functions shown in the table below can be changed by means of these DIP switches.

* All DIP switches are set to OFF at the time of shipment.

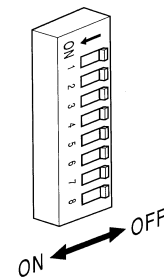

Switch	Motion when set to ON	
DIPA-1	Presser does not automatically lift after sewing is completed.	See "12-2. Setting the presser mode"
DIPA-2	Two-pedal mode is available.	
DIPA-3	User program mode is available.	
DIPA-4	—	
DIPA-5	The presser does not rise automatically when a split is found.	
DIPA-6	Displays the enlargement/reduction ratio in millimeter units instead of as a percentage. (After changing this setting, be sure to carry out the auto-clear operation by referring to page 38.)	
DIPA-7	Enlargement of pattern size is not available.	
DIPA-8	Program number is fixed.	

14-2. Setting the presser mode

Through the combination of DIP switches A-1 and A-2 on the operation panel, presser motions can be set as follows:

DIPA-1	DIPA-2	Pedal specifications	Raising the presser at the sewing end
—	—	Single pedal	Presser is raised automatically.
ON	—	Single pedal	Presser is raised by pressing the pedal.
—	ON	Two pedals	Presser is raised automatically, then it is lowered by pressing the pedal.
ON	ON	Two pedals	Presser is kept lifted while the pedal is pressed.

14. Changing functions using the DIP switches

14-3 . DIP switches inside the control box

DANGER



Wait at least 5 minutes after turning off the power switch and disconnecting the power cord from the wall outlet before opening the face plate of the control box. Touching areas where high voltages are present can result in severe injury.

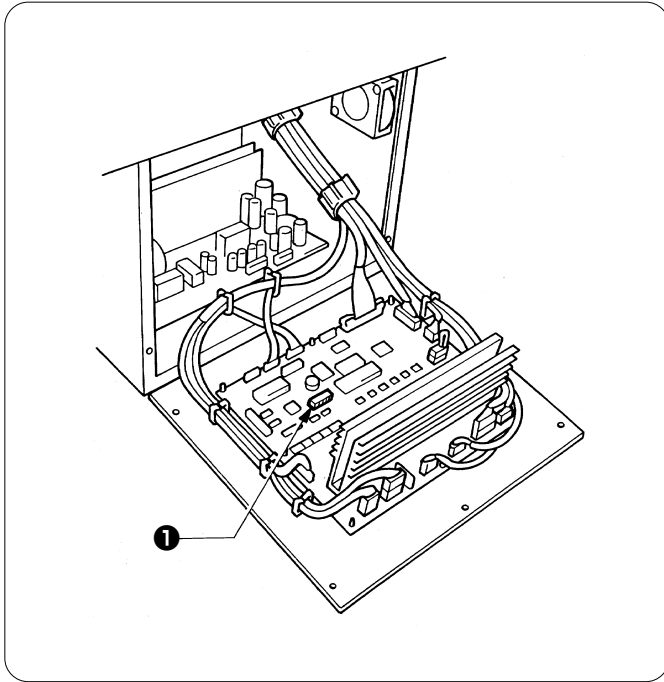

The DIP switches ❶ inside the control box are used to change functions which do not often need to be changed once they have been set.

The functions can be changed as shown in the table below by changing the positions of the DIP switches ❶.

* All DIP switches are set to OFF at the time of shipment.

NOTE:

When opening the cover, hold it securely so that it does not fall down.

Switch	Motion when set to ON
DIPB-1	First two stitches are sewn at a low speed of 260 rpm.
DIPB-2	Last two stitches are sewn at a low speed of 260 rpm.
DIPB-3	—
DIPB-4	Last two stitches are sewn at a low speed of 700 rpm.
DIPB-5	First two stitches are sewn at a low speed of 400 rpm.
DIPB-6	Low speed sewing is not performed at the start of sewing.
DIPB-7	The motor operates in reverse when the upper shaft stops, to return the needle bar to close to its highest position.
DIPB-8	Area checking of the sewing data is not carried out.

15. Changing special functions using the memory switches

The functions of the switches on the operation panel ① can be changed to carry out special functions.

NOTE:

After changing the memory switch settings, press the power switch to turn the power off and then back on again.
The memory switches "00 - 2F" (except "08") are set to OFF at the time of shipment.

- Turn on the power switch.
- While pressing the TEST switch ②, press the BOBBIN. WIND switch ③.
- * "00 - -" will appear in the display window ④.
- Press the DISPLAY SET switches ⑤ to set the two digits at the left of the display window ④ to the corresponding number (00 to 4F) of the function shown in the table below that you would like to select.
- When the BOBBIN. WIND switch ③ is pressed, the two spaces at the right in the display window will change from "--" to "ON".
- * If you press the RESET switch ⑥ at this time, memory switches from 00 to 2F will all be set to OFF ("--"), and memory switches from 30 to 4F will be returned to their initial settings.
- Press the TEST switch ②.
- * The display will return to normal.

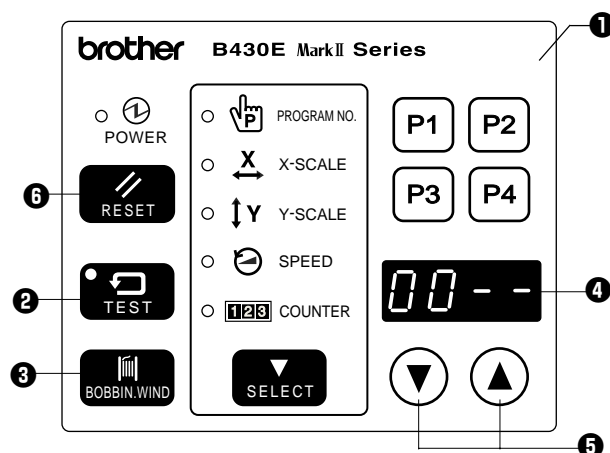

15-1. Clearing all memory settings

If the sewing machine stops operating normally, the cause may be that an incorrect memory setting may have been made by means of the memory switch, for instance. In such cases, carry out the following procedure to clear the memory, and also check the DIP switch settings.

[Method]

While pressing the RESET switch, turn on the power. This will clear all of the memory setting.

NOTE:

- This operation causes all settings stored in memory such as memory switch and user program settings to be cleared.
- If the optional emergency stop switch has been installed, you should reset memory switch No. 10 to ON.

Memory switches 00 - 0F

Switch	Motion when set to ON
memo-00	At the end of sewing, the feed plate will be returned to the sewing start point via mechanical home position.
memo-01	Button clamp will move to the sewing start point, and then will be lifted. (The button clamp rises at the final stitch to enable the quick taking out of the workpieces.)
memo-02	Feed will move automatically to the next starting point at the same time as a user program is switched. (Normally it moves to the starting point after sewing starts.)
memo-03	When sewing using programs, the programs which have been set will be sewn in numerical order. (Cycle sewing mode is set.)
memo-04	The sewing speed will be fixed at the minimum speed for the maximum pitch of the sewing data. (Set this to ON if you are concerned that variations in pitch may cause changes in the sewing speed.)
memo-05	Increases the presser solenoid lifting force
memo-06	Enlargement and reduction ratio settings for X and Y become the same.
memo-07	—
memo-08 *	Test feeding is carried out stitch by stitch when the foot switch is depressed.
memo-09	The sewing start point becomes the reference point for enlargements and reductions. (The reference point for enlargements and reductions is normally the center of the sewing frame.)
memo-0A	—
memo-0b	—
memo-0c	Needle stops in up position during emergency stop. (EMERGENCY STOP switch is available as an option.)
memo-0d	The bar tacking stitches (with a pitch of less than 1 mm) are also enlarged and reduced. (Normally stitches with a pitch of less than 1 mm are not enlarged or reduced.)
memo-0E	Test feeding will be performed at the same speed as that for actual sewing. (This is used for checking feeding operation.)
memo-0F	After sewing is finished, the work clamp automatically opens and closes once (practice operation).

* Set to ON at the time of shipment from the factory, and when all memory settings are initialized.

15. Changing special functions using the memory switches

■ Memory switches 10 - 1F

Switch	Motion when set to ON
memo-10	The optional emergency stop switch can be used.
memo-11 - memo-13	—
memo-14	Solenoid wiper can be used (available as an option).
memo-15	—
memo-16	Needle cooler output is enabled. (Needle cooler is available by special order.)
memo-17	Thread take-up device is not operated at the sewing end.
memo-18	Thread take-up device operates one stitch before the sewing end.
memo-19	Presser position errors are not detected.
memo-1A	Needle up stop position errors are not detected.
memo-1b	Presser can be moved up and down before the home position is detected. (Normally the presser cannot be moved up and down until after the home position has been detected.)
memo-1c	—
memo-1d	—
memo-1E	Errors can be reset using the EMERGENCY STOP switch. (EMERGENCY STOP switch is available as an option.)
memo-1F	Thread is not trimmed when an emergency stop occurs during sewing. (EMERGENCY STOP switch is available as an option.)

■ Memory switches 20 - 2F

Switch	Motion when set to ON
memo-20	Machine head from previous B430E series is used. (Only the operation panel and box are Mark II.)
memo-21	Rotating-type thread breakage detector operates. (Device is available by special order.)
memo-22	During thread breakage detection, sensitivity is decreased from 8 to 14 stitches at the sewing start. (Sensitivity during sewing is three stitches.)
memo-23	When DIP switch A-8 is simultaneously ON, setting values changed using the operation panel are ignored.
memo-24 - memo-2F	—

■ Memory switches 30 - 4F

30 to 4F are set by entering two-digit values.

These values are incremented using the P2 switch, and decremented using the P4 switch.

Switch	Possible setting range	Units	Initial value	Explanation
memo-30	0 - 30	mm	7	Limits the maximum area in the horizontal direction (X) (Limited to 6.4 mm when settings have been initialized.)
memo-31	0 - 30	mm	7	Limits the maximum area in the vertical direction (Y) (Limited to 6.4 mm when settings have been initialized.)
memo-32	12 - 27	x 100rpm	25	Changes the maximum sewing speed.
memo-33	1 - 15	x 7.5°	10	Changes the feed timing 1 (Fast) ~10 (Standard) Æ15 (Slow)
memo-34	0 - 5	Needle	1	The sewing speed at the sewing start is 400 rpm for the specified number of stitches.
memo-35	3 - 9	x 100rpm	4	Changes the sewing start speed specified by memo-34.
memo-36	0 - 99	x10ms	0	Timer for controlling timing during continuous operation
memo-37	1 - 20	x 7.5°	10	Changes the feed timing one stitch before the sewing end. 1 (Fast) ~10 (Standard) Æ20 (Slow)
memo-38	1 - 20	x 7.5°	10	Changes the feed timing two stitches before the sewing end.
memo-39	1 - 20	x 7.5°	1	Changes the feed timing for the third stitch at the sewing start. 1 (Fast) ~10 (Standard) Æ20 (Slow)
memo-3A	1 - 20	x 7.5°	1	Changes the feed timing for the second stitch at the sewing start.
memo-3b	1 - 20	x 7.5°	1	Changes the feed timing for the first stitch at the sewing start.
memo-3c	—	—	—	—
memo-3d	—	—	—	—
memo-3E	—	—	—	—
memo-3F	—	—	—	—
memo-40 - memo-4F	—	—	—	—

16. Table of error codes

DANGER

 Wait at least 5 minutes after turning off the power switch and disconnecting the power cord from the wall outlet before opening the face plate of the control box. Touching areas where high voltages are present can result in severe injury.

If a malfunction should occur with the sewing machine, a buzzer will sound and an error code will appear in the display window. Follow the remedy procedure to eliminate the cause of the problem.

Code	Cause	Remedy
E-13	Machine specification select connector is not connected properly.	Turn off the power and check if connectors P3 is disconnected.
E-20	Problem with machine motor stopping, or synchronizer connection error.	Turn off the power, and then turn the machine pulley to check if the machine has locked up. Check the synchronizer connection. Check if connectors P11, P12 and P13 are disconnected.
E-21	Machine motor operation error.	Turn off the power and check the ground wire connection.
E-30	Data is outside possible sewing area due to enlargement ratio setting.	Press the RESET switch, and then set the enlargement ratio again.
E-31	Stitch pattern data overlaps the sewing area when area limiting is active.	Press the RESET switch, and then reset the memory switches "30" and "31" or enlargement ratio.
E-32	The data format of the user program (% or mm) does not match the setting of DIP switch A-6.	After changing the setting of DIP switch A-6, clear all memory settings. (Refer to "15-1. Clearing all memory settings".)
E-40	Length of a stitch exceeds 10 mm.	Press the RESET switch, and then set the enlargement ratio again.
E-41	Abnormality in the sewing data.	If programming a new sewing data, repeat the procedure from the beginning.
E-42	Invalid program number specified.	Press the RESET switch and specify a correct number.
E-50	Needle bar does not stop when the needle is raised.	Turn the pulley to align the index mark with the needle up stop position. (Refer to "10-12. Adjusting the needle up stop position".) Check the V-belt tension. (Refer to "3-18. Installing the V-belt".)
E-60	Presser has not been lowered.	Refer to "18. Troubleshooting". Turn off the power and check the connection of presser sensor connector P1.
E-61	Presser cannot be raised.	
E-62	Presser is not raised.	
E-63	Presser cannot be lowered.	
E-70	Cooling fan does not operate.	Turn off the power, and then check if the cooling fan is blocked with scraps of thread.
E-80	Motor PROM is not correctly inserted.	Turn off the power and check.
E-81	Foot switch was depressed when the power was turned on.	Turn off the power and check.
E-82	An operation panel switch was depressed when the power was turned on.	Turn off the power and check the operation panel. Check that all panel cords are normal.
E-90	Abnormal drop in power supply voltage, or power was turned on again immediately after it was turned off.	Turn off the power and check the input voltage. After turning off the power, wait 3 seconds or more before turning it on again. (Refer to "10-15. Checking the input voltage".)
E-91	Abnormal rise in power supply voltage.	Turn off the power and check the input voltage. (Refer to "10-15. Checking the input voltage".)

16. Table of error codes

Code	Cause	Remedy
E-A0	Home position cannot be detected (malfunction of home position sensor), or malfunction of power supply circuit board.	Turn off the power and check the connection of home position sensor connector P1.
E-b0	You tried to change the program number when DIP switch A-8 was set to ON.	Press the RESET switch. Set DIP switch A-8 to OFF before trying to change the program number.
E-C3	Button attachment error •Button feeding error •Button blockage •Button feeder is in adjustment mode	Remove the cause of the error at the robot. •Press the MANUAL switch on the button feeder to feed the buttons. •Refer to section 10-15. •Press the RESET switch to stop the buzzer from sounding. The error code display will not disappear until adjustment mode has been canceled.
E-d0	Heat sink of control circuit board is abnormally hot.	Turn off the power and clean the air intake port of the box.
E-E0	Malfunction of EEPROM (malfunction of main circuit board).	Turn off the power, and turn it back on. If the error continually occurs, contact a qualified service technician.
E-E1	Corrupted EEPROM data, or main PROM version has been upgraded.	Press the RESET switch to reset the error. However, the data (memory switches, display and user programs) will be reset to the backup data or initialized.
E-E2	Corrupted EEPROM control information data.	Press the RESET switch to reset the error. However, the data (memory switches, display and user programs) will all be initialized.
E-F0	Solenoid short-circuit (malfunction of main circuit board), or power relay is not operating (malfunction of power supply circuit board).	Turn off the power and contact a qualified service technician.
E-F1	Bad connection in cable between power supply circuit board and main circuit board.	Turn off the power and check if connectors P16 is disconnected.
E-F2	Abnormal current detected in power supply circuit board.	Turn off the power and contact a qualified service technician.





■ Errors generated when optional equipment is connected

Code	Cause	Remedy
E-10	Emergency stop switch was pressed.	Turn the EMERGENCY STOP switch clockwise to release the lock, and then press the RESET switch to reset the error.
E-11	Emergency stop switch was pressed during sewing.	Turn the EMERGENCY STOP switch clockwise to release the lock, and then press the RESET switch to reset the error. You can then press the STEP BACK switch to repeat the sewing.
E-12	Emergency stop switch is being continually pressed, or emergency switch connection error.	Turn off the power and check.
E-14	Thread breakage detected.	Turn the EMERGENCY STOP switch clockwise to release the lock, and then press the RESET switch to reset the error. You can then press the STEP BACK switch to repeat the sewing.

REFERENCE segment LED alphabet

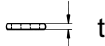
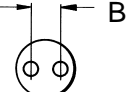
	Panel display	<i>A</i>	<i>b</i>	<i>c</i>	<i>d</i>	<i>E</i>	<i>F</i>	<i>6</i>	<i>H</i>	<i>L</i>	<i>o</i>
	Text display	A	b	c	d	E	F	6	H	L	o

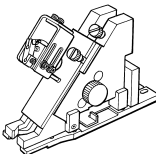
17. Adjustment guide refer to this guide when different button are used

	When button diameter (D) changes 	When button thickness (t) changes 	When button hole gap (B) changes 	Page	
Vibrating Bowl 	Adjust button selector	/	/		
Adjust button guide	/			/	
					Adjust height control plate
Adjust button adjustment dial				/	/
Shoot Coil assy 	Replace the shoot coil		/		
Button Slide Base 	Adjust slide base width	/		/	
Adjust the stopper	/		/		
Replace the button top cover					/
	Replace the spacer (S)		/		
Button Catch Plate 	/	/		Replace the button carrier	
Feeder Installation Position			/	/	Adjust right/left needle and button carrier pin positions
Machine Head	Adjust button clamp width	/			/
	/		Adjust needle location		

18. Troubleshooting

Problem	Cause	Check	Remedy	Page
Button clamp does not rise.	Button clamp lifter amount is too great.	Distance between button clamp and top of needle plate	Adjust the height of the button clamp to within 13 mm.	46
	Presser is contacting thread wiper.	Thread wiper standby position	Adjust the position of the thread wiper.	48
Button clamp does not drop.	Presser lifter link is not moving back.	Link return spring is unhooked.	Hook the link return spring properly.	
Button clamp lift amount is incorrect.	Incorrect position of button clamp holder hook assembly	Distance between button clamp and top of needle plate	Adjust the button clamp lift amount.	46
Thread wiper does not operate correctly.	The thread wiper is obstructing the needle.	Clearance between thread wiper and needle tip	Adjust the height of the thread wiper.	48
	Thread wiper position is incorrect.	Thread wiper position	Adjust the operating distance of the thread wiper.	48
Lower thread winds to one side.	Bobbin winder thread tension stud height is incorrect.	Bobbin winder thread tension stud height	Adjust the height of the thread tension stud.	29
Lower thread winding amount is incorrect.	Bobbin presser position is incorrect.	Thread winding amount	Adjust the position of the bobbin presser.	29
Threads comes unthreaded.	Stitches being skipped at the sewing start.	Refer to "Skipped stitches occur".	Refer to "Skipped stitches occur".	
	Uneven upper thread length.	Upper thread length	Adjust the sub-tension.	29

Problem	Cause	Check	Remedy	Page
Upper thread breaks.	Upper thread tension is too strong.	Upper thread tension	Adjust the upper thread tension.	27
	Needle is installed incorrectly.	Needle direction	Install the needle so that the groove is facing forward.	27
	Thread is too thick for the needle.	Thread and needle	Use the correct thread for the needle.	27
	Thread takeup spring tension and height are incorrect.	Thread takeup spring tension and height	Adjust the tension and height of the thread takeup spring.	29
	Damaged or burred rotary hook, needle hole plate or needle	Damage or burring	File smooth or replace the affected part.	
Lower thread breaks.	Lower thread tension is too strong.	Lower thread tension	Adjust the lower thread tension.	28
	Corners of needle hole plate or bobbin case are damaged.	Damage	File smooth or replace the affected part.	
Skipped stitches occur.	Clearance between needle and rotary hook tip is too great.	Needle clearance	Adjust the needle clearance.	42
	Incorrect needle and rotary hook timing	Needle bar lift amount	Adjust the needle bar lift amount.	41
	Driver is contacting needle more than is necessary.	Clearance between driver and needle	Adjust the driver needle guard.	42
	Needle is bent.	Bent needle	Replace the needle.	
	Needle is installed incorrectly.	Needle direction	Install the needle so that the groove is facing forward.	27
Needle breaks.	Needle is striking the button.	Needle down setting	Adjust so that the needle drops down into the hole of the button.	40,46
	Needle is touching the rotary hook.	Needle clearance	Adjust the needle clearance.	42
		Needle bar lift amount.	Adjust the needle bar lift amount.	41
	Needle is bent.	Bent needle	Replace the needle.	
	Wayward stitches	Needle and feed timing	Adjust the needle down detection position.	52
	Needle is too thin.	Needle and thread	Use the correct needle for the material.	

18. Troubleshooting

Problem	Cause	Check	Remedy	Page
Upper thread is not trimmed.	Fixed knife is blunt.	Fixed knife blade	Sharpen or replace the fixed knife.	/
	Movable knife does not pick up the thread.	Shuttle race thread guide position	Adjust the position of the shuttle race thread guide.	43
		Needle bar lift amount	Adjust the needle bar lift amount.	41
	The movable knife does not pick up the thread because of skipped stitches at the sewing end.	Skipped stitches at sewing end	Refer to "Skipped stitches occur".	/
	Movable knife position is incorrect.	Movable knife position	Adjust the position of the movable knife.	45
Sub-tension is too weak.	Sub-tension	Turn the sub-tension nut to adjust the tension.	27	
Thread jamming	Thread takeup spring tension and height are incorrect.	Thread takeup spring tension and height	Adjust the tension and height of the thread takeup spring.	30
	Incorrect needle and rotary hook timing	Needle bar lift amount	Adjust the needle bar lift amount.	41
	Shuttle race thread guide is not separating the threads.	Shuttle race thread guide position	Adjust the position of the shuttle race thread guide.	43
Poor seam finish on reverse side of material.	Shuttle race thread guide is not separating the threads.	Shuttle race thread guide position	Adjust the position of the shuttle race thread tension.	43
	Upper thread is not properly tight.	Upper thread tension	Adjust the upper thread tension.	29
	Uneven upper thread length	Upper thread length	Adjust the sub-tension.	27
Incorrect thread tightness	Upper thread tension is too weak.	Upper thread tension	Adjust the upper thread tension.	29
	Lower thread tension is too weak.	Lower thread tension	Adjust the lower thread tension.	29
	Thread takeup spring tension and height are incorrect.	Thread takeup spring tension and height	Adjust the tension and height of the thread takeup spring.	30
Button breaks.	Needle is striking the button.	Needle down setting	Adjust so that the needle drops into the hole of the button.	40,46

brother[®]

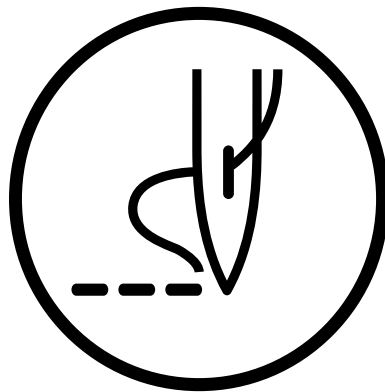

INSTRUCTION MANUAL

BROTHER INDUSTRIES, LTD.

15-1, Naeshiro-cho, Mizuho-ku, Nagoya 467-8561, Japan. Phone: 81-52-824-2177

Printed in Japan

151-916
S93V48-002
2000.06. H (1)