

# Overlock Sewing Machine N series

## EF4-N11

High Speed Single Needle  
Overlock Sewing Machine

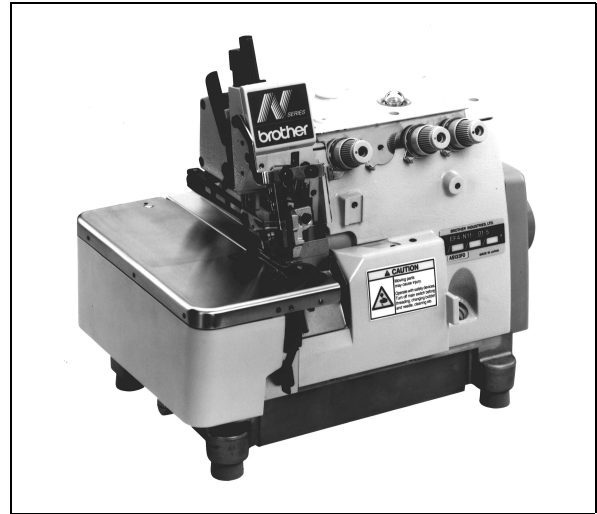

## EF4-N21

High Speed Twin Needle  
Overlock Sewing Machine



## MA4-N31

High Speed Safety Stitch  
Sewing Machine

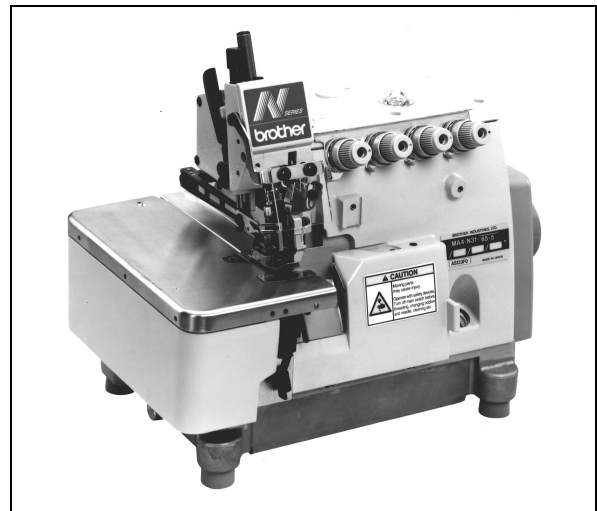

# Overlock Sewing Machine V series

## EF4-V41A

Ultra high Speed Single Needle  
Overlock Sewing Machine

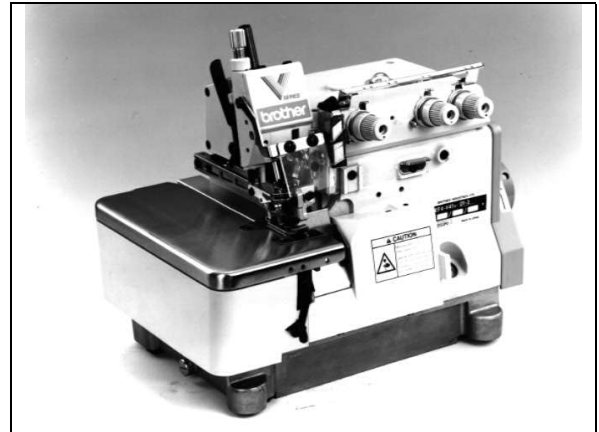

## EF4-V51A

Ultra high Speed Twin Needle  
Overlock Sewing Machine

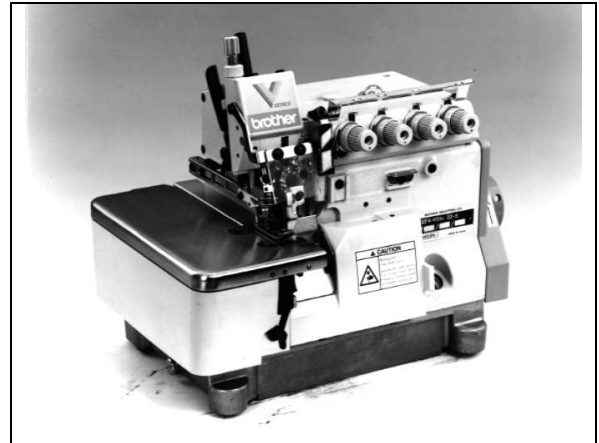

## MA4-V61A

Ultra high Speed Safety Stitch  
Sewing Machine

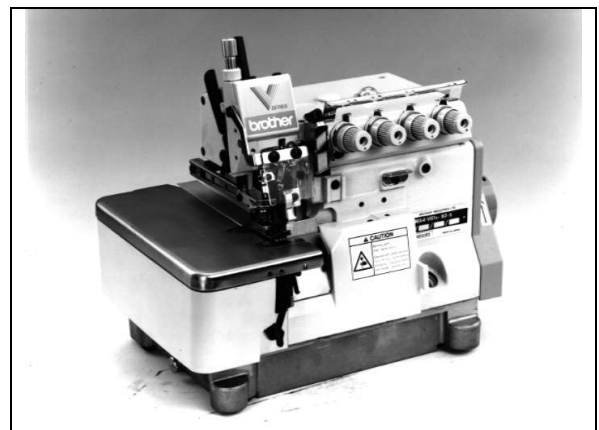

## Option parts

[Models EF4-N11, N21, MA4-N31, V41A, V51A, V61A]

Device		Model	N11 V41A	N21 V51A	N31 V61A
Automatic tape cutter	Stitch number control	ATC1	○	○	○
	Air suction + Thread release + Stitch number control	ATC3	○	○	○
	Air suction + Stitch number control	ATC5	○	○	○
Automatic tape feeder	Horizontal (Installed on the table)	TFH	○	○	○
	Vertical (Installed on the table)	TFV	○	○	○
Semi-auto backtack device	For single needle	SBL1	○	-	-
	For twin needle	SBL2	-	○	-
Vertical chain cutter	Pneumatic type back suction	CV1	○	○	-
	Pneumatic type front suction	CV3	○	○	-
	Vacuum type back suction	CV4	○	○	-
	Vacuum type front suction	CV6	○	○	-
	Chain cutter only back suction	CV7	○	○	-
	Chain cutter only front suction	CV9	○	○	-
Horizontal chain cutter	Pneumatic type	CH1	○	○	○
	Vacuum type	CH2	○	○	○
	Chain cutter only	CH3	○	○	○
Tape cutter	Knee SW pneumatic	TC1	○	○	○
	Knee SW solenoid	TC3	○	○	○
	Manual SW solenoid	TC5	○	○	○
Pneumatic foot lifter	PL1	○	○	○	
Folded edge controlling and hemming	BH	○	-	-	
Pneumatic air cleaner set	CL1	○	○	○	
Semi-automatic backlatch device	SBL	○	○	-	

# Specifications

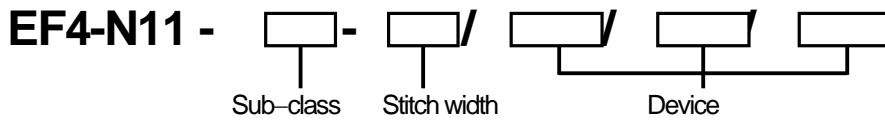

Sub-class	Applications	Stitch type	No. of needles	No. of threads	(mm) Needle gauge	(mm) Stitch width	(mm) Max. stitch length	Differential ratio
01 -3 -4 -5 -6 -7			1	3	-	3 4 5 6 7	0.9–3.8	0.7–2.0
02 -5 -6 -7	Bulky knit		1	3	-	5 6 7	0.4–2.4	1.1–3.8
03 -3 -4 -5	Blind-hemming		1	3	-	3 4 5	0.9–3.8	0.7–2.0
04 -3 -4 -5	Blind-hemming		1	2	-	3 4 5	0.9–3.8	0.7–2.0
05 -4 -5	Serging		1	2	-	4 5	1.4–5.9	0.7–1.3
06 -4 -5	Serging		1	3	-	4 5	1.4–5.9	0.7–1.3
07 -2 -3	Curing		1	3	-	2 3	0.9–3.8	0.7–2.0
08 -5	Ruffling		1	3	-	5	0.8–3.2	0.8–2.8
09 -5	Ruffling with piping		1	3	-	5	0.8–3.2	0.8–2.8
10 -4 -5 -6	Taping		1	3	-	4 5 6	0.9–3.8	0.7–2.0
11 -5 -6 -7	Taping bulky knit		1	3	-	5 6 7	0.4–2.4	1.1–3.8
12 -3 -4 -5	Back-tacking		1	3	-	3 4 5	0.9–3.8	0.7–2.0
17 -3 -4 -5	Soft chain stitching		1	3	-	3 4 5	0.9–3.8	0.7–2.0





... Light-weight materials

... Heavy-Weight materials

... Medium-weight materials

... Extra heavy-weight materials

# EF4-V41A -

 (mm) Height of presser foot	 (mm) Pitch of feed dog	 Type of feed dog (standard)	 (DC x 27) Needle size	 (rpm) Max. speed		Looper locus	Attachment
				V41A	N11		
5	1.6	3-Row	11	8,500	7,000	S	
				8,500	7,000	S	
				8,500	7,000	S	
				8,000	6,700	H	
				8,000	6,700	H	
6	2.5	3-Row	14	8,000	6,500	H	Angle knife
5	1.6	2-Row	9	8,500	7,000	S	Blind hemming ruler
5	1.6	2-Row	9	8,500	7,000	S	Blind hemming ruler
5	1.6	2-Row	14	8,500	7,000	S	Serging ruler
5	1.6	2-Row	14	8,500	7,000	S	Serging ruler
5	1.6	2-Row	11	8,500	7,000	S	
5	1.6	3-Row	11	7,500	6,500	S	Ruffler
5	1.6	3-Row	11	7,500	6,500	S	Piping ruffler
5	1.6	3-Row	11	8,500	7,000	S	Tape guide
				8,500	7,000	S	
				8,000	6,700	H	
6	2.5	3-Row	14	8,000	6,500	H	Tape guide Angle knife
5	1.6	2-Row	11	8,500	7,000	S	Back-tack
5	1.6	3-Row	11	8,500	7,000	S	

Over-looper locus  
 S ... Standard lift  
 H ... High lift  
 E ... Extra high lift

# Specifications

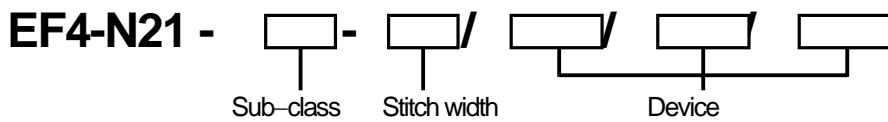

Sub-class	Applications	Stitch type	No. of needles	No. of threads	(mm) Needle gauge	(mm) Stitch width	(mm) Max. stitch length	Differential ratio
22 -4 -5 -6 -7			2	4	2.2	4 5 6 7	0.9–3.8	0.7–2.0
23 -4 -5 -6 -7	 Mock safety stitch		2	4	2.2	4 5 6 7	0.9–3.8	0.7–2.0
24 -5 -6 -7			2	4	3	5 6 7	0.9–3.8	0.7–2.0
25 -5 -6 -7	 Mock safety Stitch		2	4	3	5 6 7	0.9–3.8	0.7–2.0
27 -5 -6 -7	Bulky knit		2	4	2.2	5 6 7	0.4–2.4	1.1–3.8
28 -5 -6 -7	Bulky knit Mock safety stitch		2	4	2.2	5 6 7	0.4–2.4	1.1–3.8
31 -6 -7			2	4	3	6 7	1.2–5.0	0.7–1.4
32 -6 -7	 Mock safety stitch		2	4	3	6 7	1.2–5.0	0.7–1.4
33 -5 -6	Ruffling		2	4	2.2	5 6	0.8–3.2	0.8–2.8
34 -5 -6	Ruffling Mock safety stitch		2	4	2.2	5 6	0.8–3.2	0.8–2.8

... Light-weight materials





... Heavy-Weight materials

... Medium-weight materials

... Extra heavy-weight materials

**EF4-V51A -**  -  /  /  /

Sub-class      Stitch width      Device

 (mm) Height of presser foot	 (mm) Pitch of feed dog	 Type of feed dog (standard)	 (DC x 27) Needle size	 (rpm) Max. speed		Looper locus	Attachment
				V51A	N21		
5.5	1.6	3-Row	11	8,000	6,700	H	
5.5	1.6	3-Row	11	7,000	6,700	H	
5.5	1.6	3-Row	11	8,000	6,700	H	
5.5	1.6	3-Row	11	7,000	6,700	H	
5.5	2.5	3-Row	14	8,000	6,500	H	Angle knife
5.5	2.5	3-Row	14	7,000	6,500	H	Angle knife
6	2.5	3-Row	18	6,500	6,000	E	Angle knife
6	2.5	3-Row	18	5,500	5,500	E	Angle knife
5.5	1.6	3-Row	11	7,500	6,500	H	Ruffler
5.5	1.6	3-Row	11	7,500	6,500	H	Ruffler

Over-looper locus  
 S ... Standard lift  
 H ... High lift  
 E ... Extra high lift

# Specifications

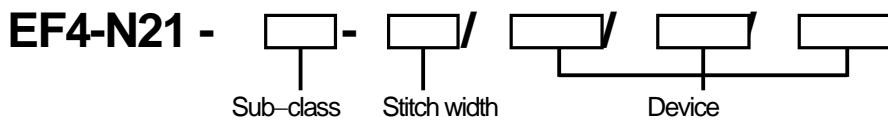





Sub-class	Applications	Stitch type	No. of needles	No. of threads	(mm) Needle gauge	(mm) Stitch width	(mm) Max. stitch length	Differential ratio
37	-5 Ruffling with piping -6		2	4	2.2	5 6	0.8–3.2	0.8–2.8
38	-5 Ruffling with piping -6		2	4	2.2	5 6	0.8–3.2	0.8–2.8
41	-5  Taping -6		2	4	2.2	5 6	0.9–3.8	0.7–2.0
42	-5  Taping -6 Mock safety stitch		2	4	2.2	5 6	0.9–3.8	0.7–2.0
45	-5 Taping -6 Bulky knit -7		2	4	2.2	5 6 7	0.4–2.4	1.1–3.8
46	-5 Taping -6 Bulky knit -7 Mock safety stitch		2	4	2.2	5 6 7	0.4–2.4	1.1–3.8
49	-5  Back-tacking -6		2	4	2.2	5 6	0.9–3.8	0.7–2.0
57	-6 Bulky knit -7		2	4	2.5	6 7	0.4–2.4	1.1–3.8
58	-6 Bulky knit Back-tack		2	4	2.5	6	0.4–2.4	1.1–3.8

... Light-weight materials      ... Heavy-Weight materials  
 ... Medium-weight materials      ... Extra heavy-weight materials



**EF4-V51A** - Sub-class - Stitch width / Device

 (mm) Height of presser foot	 (mm) Pitch of feed dog	 Type of feed dog (standard)	 (DC x 27) Needle size	 (rpm) Max. speed		Looper locus	Attachment
				V51A	N21		
5	1.6	3 - Row	11	7,500	6,500	H	Piping ruffler
5	1.6	3 - Row	11	7,000	6,500	H	Piping ruffler
5.5	1.6	3 - Row	11	8,000	6,700	H	Tape guide
5.5	1.6	3 - Row	11	7,500	6,700	H	Tape guide
5.5	1.6	3 - Row	14	8,000	6,500	H	Tape guide Angle knife
5.5	1.6	3 - Row	14	7,000	6,500	H	Tape guide Angle knife
5.5	1.6	3 - Row	11	8,000	6,700	H	Back-tack
7	2.5	3 - Row	14	6,500	6,000	E	Angle knife
7	2.5	3 - Row	14	6,500	6,000	E	Angle knife

Over-looper locus  
 S ... Standard lift  
 H ... High lift  
 E ... Extra high lift

# Specifications







Sub-class	Applications	Stitch type	No. of needles	No. of threads	(mm) Needle gauge	(mm) Stitch width	(mm) Max. stitch length	Differential ratio
61 -2 -3 -4 -5			2	5	2	2 3 4 5	0.9-3.8	0.7-2.0
62 -2 -3 -4 -5			2	4	2	2 3 4 5	0.9-3.8	0.7-2.0
63 -3 -4 -5 -6 -7			2	5	3	3 4 5 6 7	0.9-3.8	0.7-2.0
64 -3 -4 -5 -6 -7			2	4	3	3 4 5 6 7	0.9-3.8	0.7-2.0
65 -4 -5 -6 -7			2	5	5	4 5 6 7	0.9-3.8	0.7-2.0
66 -4 -5 -6 -7			2	4	5	4 5 6 7	0.9-3.8	0.7-2.0
67 -4 -5	 Ruffling		2	5	2	4 5	0.8-3.2	0.8-2.8
68 -4 -5	 Ruffling		2	4	2	4 5	0.8-3.2	0.8-2.8
69 -4 -5	 Ruffling		2	5	3	4 5	0.8-3.2	0.8-2.8
70 -4 -5	 Ruffling		2	4	3	4 5	0.8-3.2	0.8-2.8
71 -5 -6	 Ruffling		2	5	5	5 6	0.8-3.2	0.8-2.8
72 -5 -6	 Ruffling		2	4	5	5 6	0.8-3.2	0.8-2.8

... Light-weight materials      ... Heavy-Weight materials  
 ... Medium-weight materials      ... Extra heavy-weight materials

**MA4-V61A-**  -  /  /  /

Sub-class      Stitch width      Device

 (mm) Height of presser foot	 (mm) Pitch of feed dog	 Type of feed dog (standard)	 (DC x27) Needle size	(rpm) Max. speed		Looper locus	Attachment
				V61A	N31		
5	1.6	3-Row	14	7,500	6,500	S	Ruffler
5	1.6	3-Row	14	7,500	6,500	S	Ruffler
5	1.6	2-Row	11	7,500	6,500	S S S H H	
5	1.6	2-Row	11	7,500	6,500	S S S H H	
5	1.6	3-Row	14	7,500	6,500	S S H H	
5	1.6	3-Row	14	7,500	6,500	S S H H	
5	1.6	3-Row	16	7,000	6,500	S	
5	1.6	3-Row	16	7,000	6,500	S	
5	1.6	3-Row	14	7,000	6,500	S	Ruffler
5	1.6	3-Row	14	7,000	6,500	S	Ruffler
5	1.6	3-Row	14	7,000	6,500	S H	Ruffler
5	1.6	3-Row	14	7,000	6,500	S H	Ruffler

Over-looper locus  
 S ... Standard lift  
 H ... High lift  
 E ... Extra high lift

# Specifications

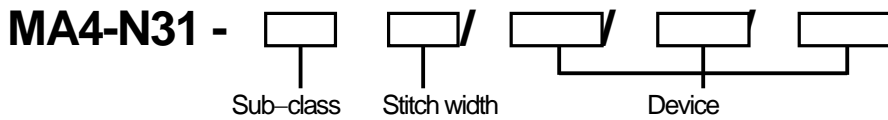





Sub-class	Applications	Stitch type	No. of needles	No. of threads	(mm) Needle gauge	(mm) Stitch width	(mm) Max. stitch length	Differential ratio
75 -5	 Ruffling with piping		2	5	3	5	0.8-3.2	0.8-2.8
76 -5	 Ruffling with piping		2	4	3	5	0.8-3.2	0.8-2.8
77 -5 -6	 Ruffling with piping		2	5	5	5 6	0.8-3.2	0.8-2.8
78 -5 -6	 Ruffling with piping		2	4	5	5 6	0.8-3.2	0.8-2.8
81 -4 -5	 Taping		2	5	3	4 5	0.9-3.8	0.7-2.0
82 -4 -5	 Taping		2	4	3	4 5	0.9-3.8	0.7-2.0
83 -4 -5 -6	 Taping		2	5	5	4 5 6	0.9-3.8	0.7-2.0
84 -4 -5 -6	 Taping		2	4	5	4 5 6	0.9-3.8	0.7-2.0
85 -3 -5	 Binding		2	5	3	3 5	1.2-5.0	0.7-1.4
86 -5	 Binding		2	4	3	5	1.2-5.0	0.7-1.4
89 -4 -5	 Binding		2	5	3	4 5	0.9-3.8	0.7-2.0

- ... Light-weight materials      ... Heavy-Weight materials  
 ... Medium-weight materials      ... Extra heavy-weight materials

**MA4-V61A-**  -  /  /  /

Sub-class      Stitch width      Device

 (mm) Height of presser foot	 (mm) Pitch of feed dog	 Type of feed dog (standard)	 (DC x27) Needle size	 (rpm) Max. speed		Looper locus	Attachment
				V61A	N31		
5	1.6	3 - Row	14	7,000	6,500	S	Piping ruffler
5	1.6	3 - Row	14	7,000	6,500	S	Ruffler
5	1.6	3 - Row	14	7,000	6,500	S H	Piping ruffler
5	1.6	3 - Row	14	7,000	6,500	S H	Piping ruffler
5	1.6	3 - Row	14	7,500	6,500	S	Tape guide
5	1.6	3 - Row	14	7,500	6,500	S	Tape guide
5	1.6	3 - Row	16	7,500	6,500	S S H	Tape guide
5	1.6	3 - Row	16	7,500	6,500	S S H	Tape guide
3.5	2.5	2 - Row	18	6,500	6,000	E	Tractor foot Angle knife
3.5	2.5	2 - Row	18	6,500	6,000	E	Tractor foot Angle knife
5	1.6	2 - Row	14	6,500	6,500	S	Binding tape guide

Over-looper locus  
 S ... Standard lift  
 H ... High lift  
 E ... Extra high lift

# Specifications

## MA4-N31 -

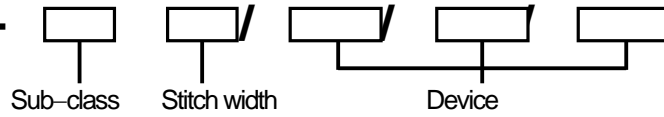

Sub-class	Applications	Stitch type	No. of needles	No. of threads	(mm) Needle gauge	(mm) Stitch width	(mm) Max. stitch length	Differential ratio
90 -4 -5	 Binding		2	4	3	4 5	0.9–3.8	0.7–2.0
92 -5 -6 -7			2	5	5	5 6 7	1.2–5.0	0.7–1.4
93 -5 -6 -7			2	4	5	5 6 7	1.2–5.0	0.7–1.4
95 -5			3	6	5 × 2.2	5	0.9–3.8	0.7–2.0
99 -5	 Ruffling		3	6	5 × 2.2	5	0.8–3.2	0.8–2.8

... Light-weight materials





... Heavy-Weight materials

... Medium-weight materials

... Extra heavy-weight materials

**MA4-V61A-**  -  /  /  /

Sub-class      Stitch width      Device

 (mm) Height of presser foot	 (mm) Pitch of feed dog	 Type of feed dog (standard)	 (DC x 27) Needle size	 (rpm) Max. speed		Looper locus	Attachment
				V61A	N31		
5	1.6	2 - Row	14	6,500	6,500	S	Binding tape guide
3.5	2.5	3 - Row	18	6,500	6,000	E	Tractor foot Angle knife
3.5	2.5	3 - Row	18	6,500	6,000	E	Tractor foot Angle knife
6	1.6	3 - Row	16	7,000	6,500	H	
6	1.6	3 - Row	14	7,000	6,500	H	Ruffler

Over-looper locus  
 S ... Standard lift  
 H ... High lift  
 E ... Extra high lift

# Gauge parts list







[Models EF4-N11, V41A]

Application	Thin · Medium			Bulky Knit	Blind hemming	
	With chain land	Without chain land	(For small type)		03	04
Sub-class	01 -3 S -4 S -5 S -6 H -7 H	01 -3(B) S -4(B) S -5(B) S -6(B) H	01 -3(C) S -4(C) S -5(C) S -6(C) H	02 -5 H -6 H -7 H	03 -3 S -4 S -5 S	04 -3 S -4 S -5 S
S=Standard H=High-lift						
1. Needle	151474-011			151474-014	151474-009	
	S19255-001 (3) (S19257-001) S19260-001 (4,5) (S19261-001) S25535-001 (6,7) (S19265-001)	S20879-001 (3) (S19257-001) S19262-001 (4,5) (S19261-001) S19264-001 (6) (S19265-001)	S29947-001 (3) (S19257-001) S29948-001(4,5) (S19261-001) S29949-001 (6) (S19265-001)	S30046-101 (5) (S19261-001) S30047-101 (6,7) (S19265-001)	S19266-001 (3,4,5) (S19268-001)	
2. Presser foot assy (Stitch tongue)						
3. Needle plate	S33023-001 (3) S19145-001 (4) S19146-001 (5) S25185-001 (6) S30081-001 (7)	S33024-001 (3) S19154-001 (4) S19155-001 (5) S19161-001 (6)	S19147-001 (5) S19148-001 (6) S25186-001 (7)	S25187-001 (3) S19149-001 (4) S19150-001 (5)		
4. Main feed dog assy (Main Feed dog) (Chain feed dog)	S19199-001 (S19200-001) (S19201-001) A	S19212-001 (S19213-001) (S19204-001) B	S19202-001 (S19955-001) (S19204-001) B	S19205-001 (S19206-001) (S19204-001) B		
5. Differential feed dog	S33025-001 (3) S19236-001 (4,5,6,7)	S33027-001 (3) S19240-001 (4,5,6)	S19237-101	S19238-001		
6. Upper knife Angle knife	Upper knife 144074-350			Angle knife S20897-101	Upper knife 144074-350	
7. Lower knife	S20899-001 (3) T = 1.0 S20582-000 (4,5,6,7) T = 1.5			S20899-001 (5) T = 1.0 S20582-001 (6,7) T = 1.5	S20582-001 T = 1.5	
8. Over looper	S20422-001 (3,4,5) A S20426-001 (6,7) H			S20428-001 C	S20422-001 A	S20421-001 L

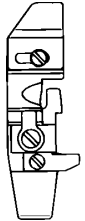
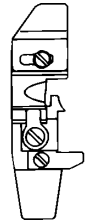
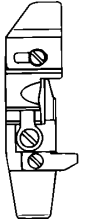
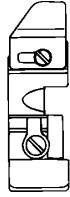
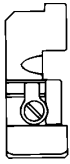
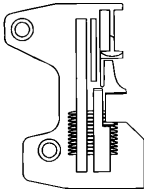
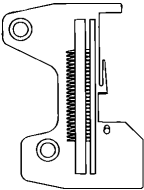
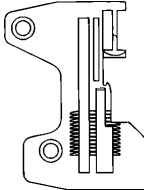
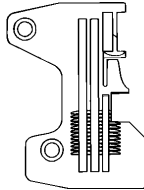
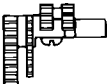

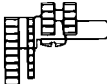
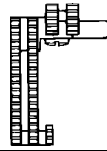
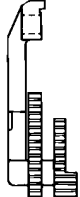
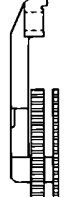
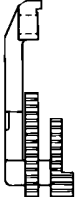
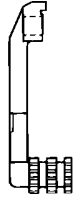

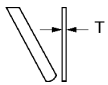





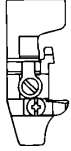
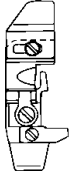
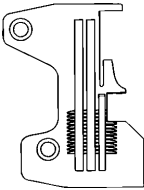
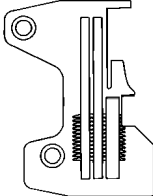
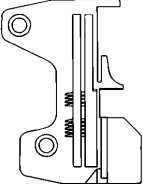
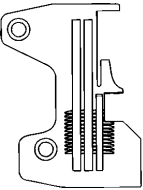
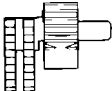
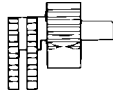

# Gauge parts list

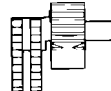
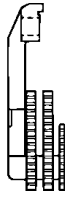
[Models EF4-N11, V41A]

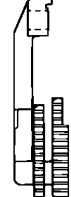
Application	Serging		Curing		Ruffing	
	2 Threads	3Threads				W/Piping
Sub-class	05 -4 S -5 S	06 -4 S -5 S	07 -2 S	07 -3 S	08 -5 S	09 -5 S
S=Standard H=High-lift						
1. Needle	151474-014		151474-011			
2. Presser foot assy (Stitch tongue)	S19269-001 (S19261-001)		S19271-001 (S19272-001)	S25536-001 (S25537-001)	S19291-001	S25538-001
						
3. Needle plate	S19151-001 (4) S19152-001 (5)		S19153-001 (2)	S25188-001 (3)	S19146-001	
						
4. Main feed dog assy (Main Feed dog) (Chain feed dog)	S19207-001 (S19208-001) (S19209-001) C		S19210-001 (S19206-001) (S19211-001) D	S25564-001 (S19208-001) (S19201-001) A	S19500-001 (S19218-001) (S19201-001) A	
						
5. Differential feed dog	S19239-001		S25574-001	S19239-001	S19243-001	
						
6. Upper knife	144074-350					
						
7. Lower knife 	S20582-001 T = 1.5					
8. Over looper 	S20423-001 M	S20424-001 B	S20422-001 A			

# Gauge parts list

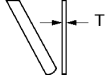
[Models EF4-N11, V41A]

Application	Taping	Bulky Knit (Taping)	Back-tacking	Soft chain
Sub-class	10 -4 S -5 S	11 -5 H -6 H	12 -3 S -4 S -5 S	17 -3 S -4 S -5 S
S=Standard H=High-lift				
1. Needle	151474-011	151474-014	151474-011	
2. Presser foot assy (Stitch tongue)	S19273-001 (S19275-001)		S25540-001 (3) (S25541-001) S19276-001 (4,5) (S19278-001)	S20879-001 (3,4) (S19257-001) S19262-001 (5) (S19261-001)
				
3. Needle plate	S19154-001 (4) S19155-001 (5)	S19147-001 (5) S19148-001 (6)	S25189-001 (3) S19156-001 (4) S19157-001 (5)	S33024-001 (3) S19154-001 (4) S19155-001 (5)
				
4. Main feed dog assy (Main Feed dog) (Chain feed dog)	S19212-001 (S19213-001) (S19204-001) B	S19202-001 (S19955-001) (S19204-001) B	S19214-001 (S19215-001) (S19216-001) E	S19212-001 (S19213-001) (S19204-001) B
				
5. Differential feed dog	S19240-001	S19237-101	S19241-001	S33027-001 (3) S19240-001 (4,5)
				
6. Upper knife Angle knife	Upper knife 144074-350	Angle knife S20897-101	Upper knife 144074-350	
				
7. Lower knife 	S20582-000 T = 1.5	S20899-001 (5) T = 1.0 S20582-001 (6) T = 1.5	S20582-001 T = 1.5	S20899-001 (3) T = 1.0 S20582-001 (4,5) T = 1.5
8. Over looper 	S20422-001 A	S20428-001 C	S20422-001 A	

# Gauge parts list

For zipper

[Models EF4-N11, V41A]



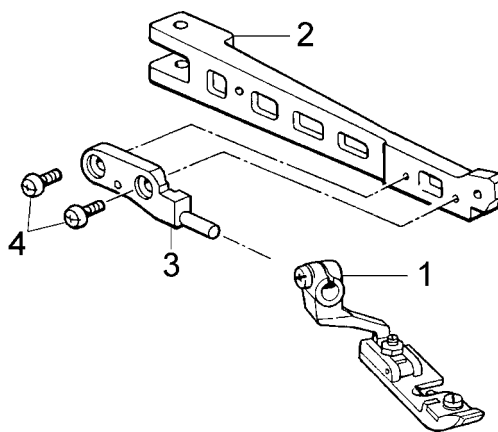
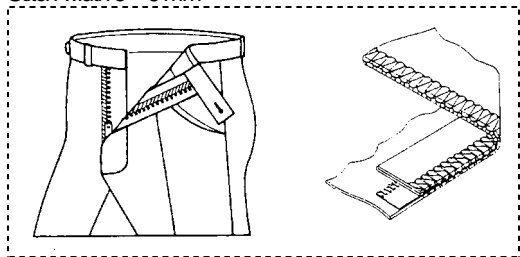





Stitch width 5 – 6 mm

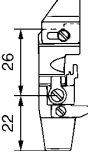
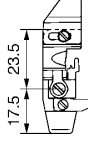
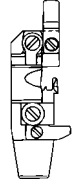

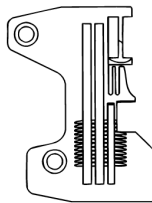
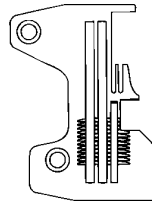
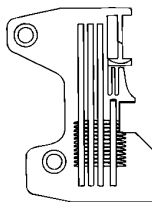
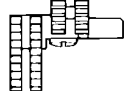
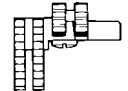
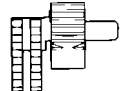
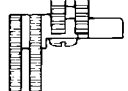
Ref. No.	Part name	Part code	Q'ty
1	Presser foot assy	S34824-101	1
2	Main presser arm	S46908-001	1
3	Presser arm	S20298-001	1
4	Screw, pan M3.5 x 6	062350-616	2

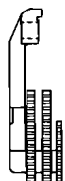

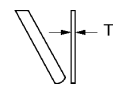
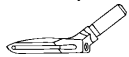

# Gauge parts list

[Models EF4-N21, V51A]

Application	Thin · Medium			Thin · Medium (For small type)		New synthetic fiber
	With chain land	(Mock-safety)	Without chain land		(Mock-safety)	
Sub-class	22 -4 H	23 -4 H	22 -4 (B) H	22 -4 (C) H	23 -5 (B) H	22 -5 (D) H
H=High-lift	-5 H	-5 H	-5 (B) H	-5 (C) H	-6 (B) H	
E=Extra high-lift	-6 H	-6 H	-6 (B) H	-6 (C) H	-7 (B) H	
	-7 H	-7 H	-7 (B) H	-7 (C) H		
(mm) Needle gauge	2.2					
1. Needle	151474-011					151474-039
2. Presser foot assy (Stitch tongue)	S25543-001 (4) (S25544-001) S19280-001 (5) (S19976-001) S19282-001 (6,7) (S19283-001)		S29952-001 (4) (S25544-001) S29950-001 (5) (S19976-001) S29951-001 (6,7) (S19283-001)		S36867-001 (S19976-001)	
3. Needle clamp assy	S20398-001					
						
4. Needle plate	S25190-001 (4) S19162-001 (5) S19163-001 (6) S25191-001 (7)		S25527-001 (4) S19169-001 (5) S19170-001 (6) S25193-001 (7)		S36866-001	
						
5. Main feed dog assy (Main Feed dog) (Chain feed dog)	S19217-001 (S19213-001) (S19201-001) A	S19199-001 (S19200-001) (S19201-001) A	S19212-001 (S19213-001) (S19204-001) B		S36738-001 (S36739-001) (S19201-001) A	
						
6. Differential feed dog	S19240-001	S19236-001	S19240-001		S36740-001	
						
7. Upper knife	144074-350					
						
8. Lower knife	S20582-001 T=1.5					
						
9. Over looper	S20424-001 B	S20436-001 (4,5,7) F S20424-001 (6) B	S20424-001 B	S20436-001 (5,7) F S20424-001 (6) B	S20424-001 B	
						

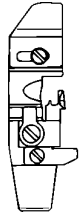
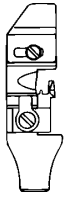
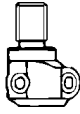
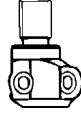
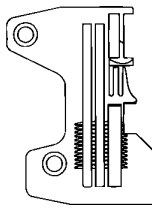
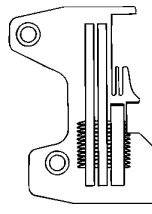
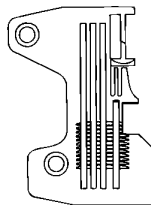
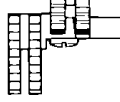
# Gauge parts list

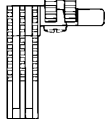
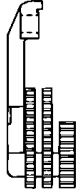
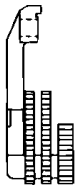
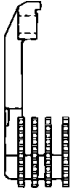
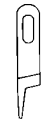
[Models EF4-N21, V51A]

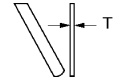
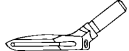
Application	Thin Medium		Bulky knit			
		(Mock-safety)		(Mock-safety)		(Mock-safety)
Sub-class	24 -5 H -6 H -7 H	25 -5 H -6 H -7 H	27 -5 H -6 H -7 H	28 -5 H -6 H -7 H	27 -5(B) H -6(B) H -7(B) H	28 -5(B) H -6(B) H -7(B) H
H=High-lift E=Extra high-lift (mm)	3		2.2			
Needle gauge	3		2.2			
1. Needle	151474-011		151474-014			
2. Presser foot assy (Stitch tongue)	S19284-001 (5) (S19976-001) S19285-001 (6) (S19286-001) S19289-001 (7) (S19975-001) 		S19287-201 (5) S19288-201 (6, 7) 			
3. Needle clamp assy	S20402-001 		S20398-001 			
4. Needle plate	S19164-001 (5) S19165-001 (6) S19168-001 (7) 		S19166-001 (5) S19167-001 (6) S25192-001 (7) 		S25528-001 (5) S19188-001 (6) S25529-001 (7) 	
5. Main feed dog assy (Main Feed dog) (Chain feed dog)	S19199-001 (S19200-001) (S19201-001) A 		S19202-001 (S19955-001) (S19204-001) B 		S24680-001 (S24681-001) (S19201-001) A 	
6. Differential feed dog	S19242-001 		S19237-101 		S30894-101 	
7. Upper knife Angle knife	Upper knife 144074-350 		Angle knife S20897-101 7.8 			
8. Lower knife 	S20899-001 (5) T=1.0 S20582-001 (6,7) T=1.5					
9. Over looper 	S20432-001 J	S20434-001 E	S20430-001 D	S20434-001 E	S20430-001 D	S20434-001 E







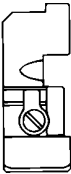

# Gauge parts list

[Models EF4-N21, V51A]

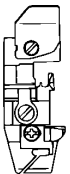
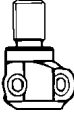
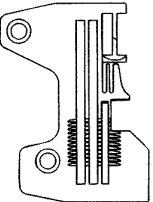
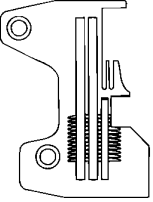
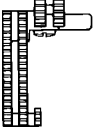
Application	Heavy materials			Ruffing	Ruffing (mock-safety)
		Mock-safety	(Tractor type)		
Sub-class	31 -6 E -7 E	32 -6 E -7 E	31 -6 (B) E -7 (B) E	33 -5 H	34 -5 H
H=High-lift E=Extra high-lift (mm)	3			2.2	
Needle gauge	3			2.2	
1. Needle	151474-018			151474-011	
2. Presser foot assy (Stitch tongue)	S29871-001(6) (S19286-001) S29869-001(7) (S19975-001) 	S30898-001 (S30900-001) 		S19291-001 	
3. Needle clamp assy	S20402-001 			S20398-001 	
4. Needle plate	S24663-001 (6) S24664-001 (7) 			S19162-001 	
5. Main feed dog assy (Main Feed dog) (Chain feed dog)	S21392-001 (S21393-001) (S21394-001) J 			S19500-001 (S19218-001) (S19201-001) A 	
6. Differential feed dog	S21395-001 			S19243-001 	
7. Upper knife Angle knife	Angle knife S20898-101 			Upper knife 144074-350 	
8. Lower knife 	S20583-001 			S20582-001 T = 1.5	
9. Over looper 	S20438-001 G	S20442-001 R	S20438-101 G	S20424-001 B	S20436-001 F

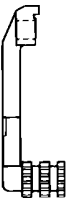
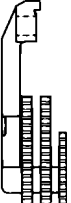
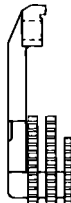

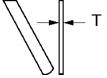



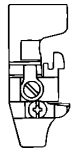

# Gauge parts list

[Models EF4-N21, V51A]

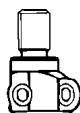
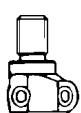
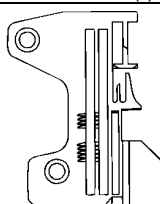
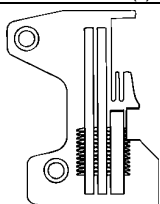
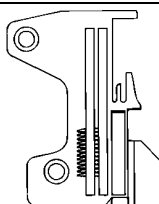
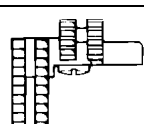
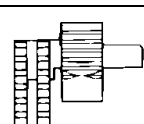
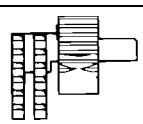
Application	Ruffing w/ piping		Taping		Bulky knit (Taping)		
		(Mock-safety)		(Mock-safety)		(Mock-safety)	
Sub-class	37 -5 H -6 H	38 -5 H -6 H	41 -5 H -6 H	42 -5 H -6 H	45 -5 H -6 H -7 H	46 -5 H -6 H -7 H	
H=High-lift E=Extra high-lift (mm)	2.2						
Needle gauge	2.2						
1. Needle	151474-011				151474-014		
2. Presser foot assy (Stitch tongue)	S25538-001 	S19293-001 (5) (S19974-001) S25546-001 (6) (S25547-001)		S19297-001 (5) (S19976-001) S19301-001 (6, 7) (S19283-001)			
3. Needle clamp assy	S20398-001 						
4. Needle plate	S19162-001 (5) S19163-001 (6) 	S19169-001 (5) S19170-001 (6) S25193-001 (7) 					
5. Main feed dog assy (Main Feed dog) (Chain feed dog)	S19500-001 (S19218-001) (S19201-001) A 	S19212-001 (S19213-001) (S19204-001) B 	S19219-001 (S19220-001) (S19204-001) B 				
6. Differential feed dog	S19243-001 	S19240-001 	S19244-101 				
7. Upper knife Angle knife	Upper knife 144074-350 				Angle knife S20897-101 7.8 		
8. Lower knife 	S20582-001 T=1.5						
9. Over looper 	S20424-001 B	S20436-001 F	S20424-001 B	S20436-001 F	S20430-001 D	S20434-001 E	

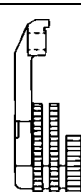
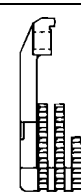
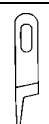
# Gauge parts list

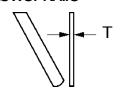





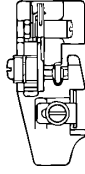
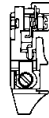
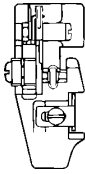

[Models EF4-N21, V51A]

Application	Back-tacking	Bulky knit	
Sub-class	49-5 H -6 H	57-6 E -7 E	58-6 E
H=High-lift E=Extra high-lift (mm)			
Needle gauge	2.2	2.5	
1. Needle	151474-011		151474-014
2. Presser foot assy (Stitch tongue)	S19302-001 (5, 6) (S19977-001) 	S19303-201 (6) (S19286-001) S20881-201 (7) (S19975-001) 	S19303-201 (S19286-001) 
3. Needle clamp assy	S20398-001 	S20400-001 	
4. Needle plate	S19981-001 (5) S19982-001 (6) 	S19173-001 (6) S20880-001 (7) 	S33529-001 
5. Main feed dog assy (Main Feed dog) (Chain feed dog)	S25007-001 (S25008-001) (S25009-001) K 	S19202-001 (S19955-001) (S19204-001) B 	S33530-001 (S33531-001) (S19204-001) B 
6. Differential feed dog	S25010-001 	S19237-101 	S33536-001 
7. Upper knife Angle knife	Upper knife 144074-350 	Angle knife S20897-101 	
8. Lower knife 	S20582-001 T = 1.5		
9. Over looper 	S20424-001 B	S20440-101 K	



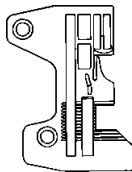
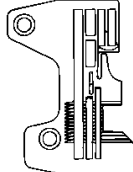
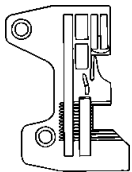
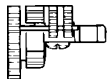

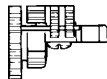
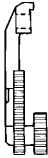
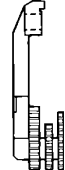

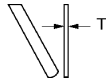
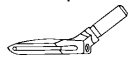

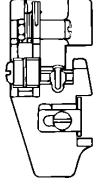
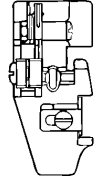

# Gauge parts list

[Models MA4-N31, V61A]

Application	Thin			Thin · Medium		
	5 Threads	4 Threads	(For small type)	5 Threads	4 Threads	(For small type)
Sub-class S=Standard H=High-lift E=Extra high-lift	61 -2 S -3 S -4 S -5 S	62 -2 S -3 S -4 S -5 S	61 -3 (B) -4 (B) -5 (B)	63 -3 S -4 S -5 S -6 H -7 H	64 -3 S -4 S -5 S -6 H -7 H	63 -3 (C) -4 (C) -5 (C)
(mm) Needle gauge	2			3		
1. Needle (Qty)	151474-011 (2)			151474-014 (2)		
2. Presser foot assy (Presser foot .F)	S19304-101 (S19312-001) 	S30586-001 (3,4) Stitch tongue S30588-001 S30592-001 (5) Stitch tongue S30593-001 	S19313-201 (S30971-001) 	S30594-001 (3,4) Stitch tongue S30588-001 S30597-001 (5) Stitch tongue S30593-001 		
3. Needle clamp assy	S29146-001 			S20404-001 		
4. Needle plate	S25194-001 (2) S25195-001 (3) S19174-001 (4) S19175-001 (5) 	S20234-001 (3) S20235-001 (4) S20236-001 (5) S35651-001 (6) S25196-001 (7) 	S19176-001 (3) S19177-001 (4) S19178-001 (5) 			
5. Main feed dog assy (Main Feed dog) (Chain feed dog)	S19221-201 (S19222-201) (S33172-001) L 	S20241-101 (S20242-101) (S20243-101) H 	S19221-201 (S19222-201) (S33172-001) L 			
6. Differential feed dog	S19245-001 			S20245-001 		
7. Upper knife	144074-350 					
8. Lower knife 	S20899-001 (2) T=1.0 S20582-001 (3,4,5) T=1.5			S20899-001 (3) S20582-001 (4,5,6,7) T=1.5		S20899-001 (2) T=1.0 S20582-001 (3,4,5) T=1.5
9. Over looper 	S20422-001 A	S20421-001 L	S20422-001 A	S20424-001 (3,4,5) B S20428-001 (6,7) C	S20423-001 (3,4,5) M S20421-001 (6,7) L	S20424-001 B

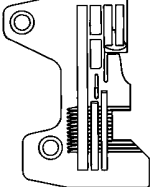
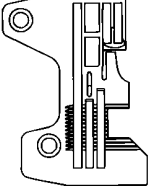
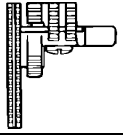
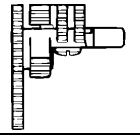
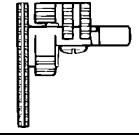

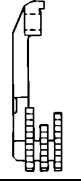
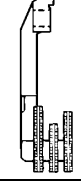
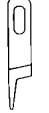
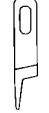

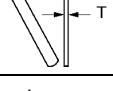
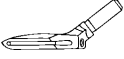

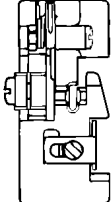
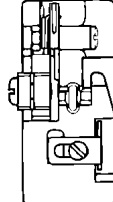
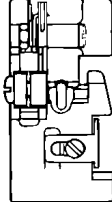

# Gauge parts list

[Models MA4-N31, V61A]

Application	New synthetic fiber	Medium thick		
		5 Threads	4 Threads	5 Threads
Sub-class S=Standard H=High-lift E=Extra high-lift	63-5 (B) S	65 -4 S -5 S -6 H -7 H	66 -4 S -5 S -6 H -7 H	65 -4 (B) H -5 (B) H -6 (B) H -7 (B) H
(mm) Needle gauge	3	5		
1. Needle (Qty)	151474-039 (2)	151474-016 (2)		
2. Presser foot assy (Presser foot .F)	S36875-101 (S19312-001)	S19317-101 (S19312-001)		
				
3. Needle clamp assy	S20404-001	S20406-001	S21104-001	
				
4. Needle plate	S36874-001	S20231-001 (4) S20232-001 (5) S20233-001 (6) S25197-001 (7)		
				
5. Main feed dog assy (Main Feed dog) (Chain feed dog)	S36871-001 (S36872-001) (S20243-101) H	S20239-101 (S20240-101) (S19223-101) F	S35840-001 (S35991-001) (S19223-101) F	
				
6. Differential feed dog	S36873-001	S20244-001	S35992-001	
				
7. Upper knife Angle knife	Upper knife 144074-350	Upper knife 144074-350	Angle knife S20896-101	
				
8. Lower knife 	S20582-001 T = 1.5			
9. Over looper 	S20424-001 B	S20424-001 (4,5) B S20428-001 (6,7) C	S20423-001 (4,5) M S20421-001 (6,7) L	S20428-001 C

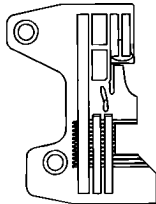
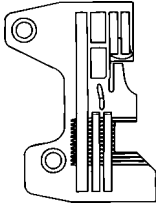
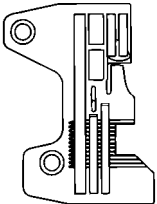
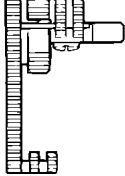
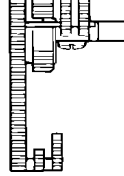
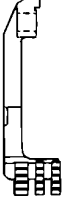

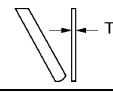



# Gauge parts list

[Models MA4-N31, V61A]

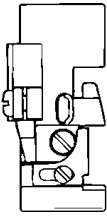
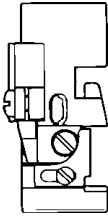
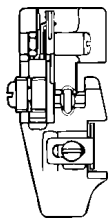
Application	Ruffing					
	5 Threads		4 Threads		4 Threads	
Sub-class S=Standard H=High-lift E=Extra high-lift (mm)	67 -4 S -5 S	68 -5 S	69 -4 S -5 S	70 -5 S	71 -5 S -6 H	72 -5 S
Needle gauge	2		3		5	
1. Needle (Qty)	151474-014 (2)					
2. Presser foot assy (Presser foot .F)	S25548-101 (S19325-001)		S19321-101 (S19325-001)		S19326-101 (S19325-001)	
						
3. Needle clamp assy	S29146-001		S20404-001		S20406-001	
						
4. Needle plate	S25198-001 (4) S25199-001 (5)		S19497-001 (4) S19182-001 (5)		S19183-001 (5) S19184-001 (6)	
						
5. Main feed dog assy (Main Feed dog) (Chain feed dog)	S19224-201 (S19225-201) (S33172-001) L				S19226-101 (5) (S19227-101) (S19223-101) F S19224-201 (6) (S19225-201) (S33172-101) L	
						
6. Differential feed dog	S19246-001					
						
7. Upper knife Angle knife	144074-350					
						
8. Lower knife 	S20582-001 T = 1.5					
9. Over loop 	S20424-001 B	S20423-001 M	S20424-001 B	S20423-001 M	S20424-001 (5) B S20428-001 (6) C	S20423-001 M



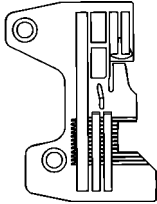
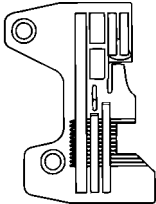
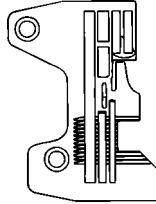
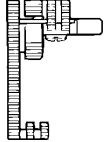
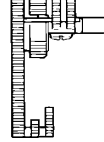
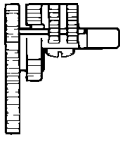
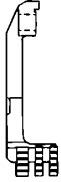
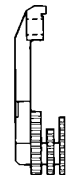

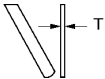
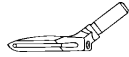

# Gauge parts list

[Models MA4-N31, V61A]

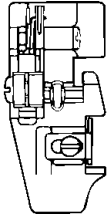
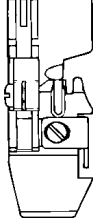
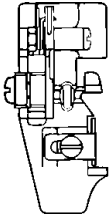
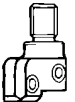
Application	Ruffing w/ piping				Taping	
	5 Threads	4 Threads	5 Threads	4 Threads	5 Threads	4 Threads
Sub-class S=Standard H=High-lift E=Extra high-lift (mm)	75 -5 S	76 -5 S	77 -5 S -6 H	78 -5 S	81 -4 S -5 S	82 -5 S
Needle gauge	2		5		3	
1. Needle (Qty)	151474-014 (2)					
2. Presser foot assy (Presser foot .F)	S25550-001 (S25553-001)	S25555-001 (S25553-001)		S19330-201 (S30971-001)		
						
3. Needle clamp assy	S20404-001	S20406-001		S20404-001		
						
4. Needle plate	S19182-001 (5)	S19183-001 (5) S19184-001 (6)		S20235-001 (4) S20236-001 (5)		
						
5. Main feed dog assy (Main Feed dog) (Chain feed dog)	S19224-201 (S19225-201) (S33172-001) L	S19226-101 (5) (S19227-101) (S19223-101) F S19224-101 (6) (S19225-201) (S33172-001) L		S20241-101 (S20242-101) (S20243-101) H		
						
6. Differential feed dog	S19246-001				S20245-001	
						
7. Upper knife	144074-350					
						
8. Lower knife 	S20582-001 T=1.5					
9. Over looper 	S20424-001 B	S20423-001 M	S20424-001 (5) B S20428-001 (6) C	S20423-001 M	S20424-001 B	S20423-001 M

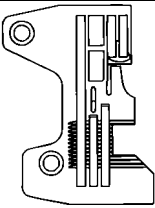
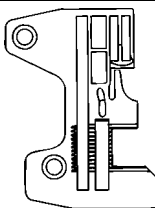
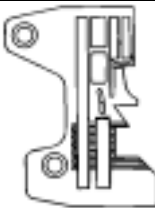
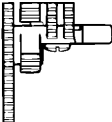
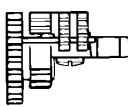
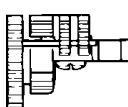
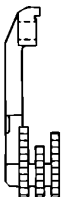
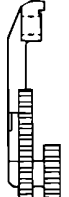
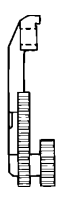



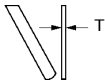
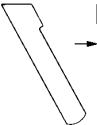
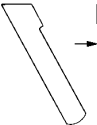
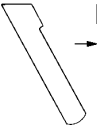
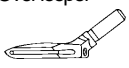



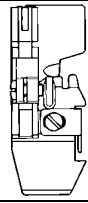
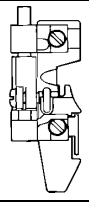
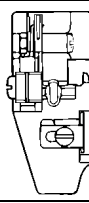
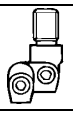

# Gauge parts list

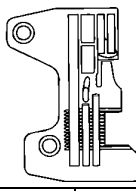
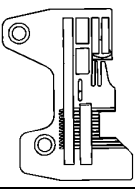
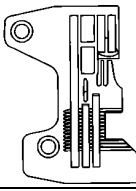
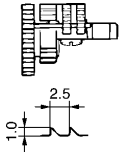
[Models MA4-N31, V61A]

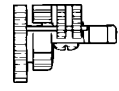
Application	Taping		Extra heavy		Binding	
	5 Threads	4 Threads	5 Threads	4 Threads	5 Threads	4 Threads
Sub-class S=Standard H=High-lift E=Extra high-lift	83 -4 S -5 S -6 H	84 -4 S -5 S -6 H	85 -3 E -5 E	86 -5 E	89 -4 S -5 S	90 -4 S -5 S
(mm) Needle gauge	5		3		3	
1. Needle (Qty)	151474-016 (2)		151474-018 (2)		151474-014 (2)	
2. Presser foot assy (Presser foot .F)	S20882-201 (S30971-001)		S25557-001 (S19340-001)		S25560-101 (S19312-001)	
						
3. Needle clamp assy	S20406-001		S29631-001		S20404-001	
						
4. Needle plate	S20231-001 (4) S20233-001 (6) S20232-001 (5)		S25200-001 (3) S25201-001 (5)		S25202-001 (4) S25203-001 (5)	
						
5. Main feed dog assy (Main Feed dog) (Chain feed dog)	S20239-101 (S20240-101) (S19232-101) F		S19228-101 (S19229-001) (S19223-101) F		S19221-201 (S19222-201) (S33172-001) L	
						
6. Differential feed dog	S20244-001		S25566-001		S19245-001	
						
7. Upper knife Angle knife	Upper knife 144074-350		Angle knife S20898-101		Upper knife 144074-350	
						
8. Lower knife 	S20582-001 T = 1.5		S20583-001 T = 1.5		S20582-001 T = 1.5	
						
9. Over looper 	S20424-001 (4,5) B S20428-001 (6) C	S20423-001 (4,5) M S20421-001 (6) L	S20438-001 G	S20429-001 Q	S20424-001 B	S20423-001 M

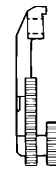
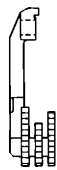

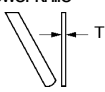
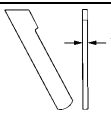

# Gauge parts list

[Models MA4-N31, V61A]

Application	Extra heavy			3 needles thin medium	
	5 Threads	4 Threads	(For vertical pocket)		
Sub-class S=Standard H=High-lift E=Extra high-lift (mm)	92 -5 E -6 E -7 E	93 -5 E -6 E	92 -5(B) E -6(B) E -7(B) E	95 -5 H	95 -5(B) H
Needle gauge	5			5, 2.2	
1. Needle (Qty)	151474-018 (2)			151474-016 (3)	
2. Presser foot assy (Presser foot .F)	S19334-001 (S19340-001)		S30525-001 (S30532-001)	S25562-101 (S19312-001)	
					
3. Needle clamp assy	S21104-001			S29148-001	
					
4. Needle plate	S19185-001 (5) S19186-001 (6) S19187-001 (7)			S25204-001	S31975-001
					
5. Main feed dog assy (Main Feed dog) (Chain feed dog)	S19228-101 (S19229-001) (S19223-101) F		S38595-001 (S38596-001) (S19223-101) F	S19221-201 (S19222-201) (S33172-001) L	S20239-101 (S20240-101) (S19223-101) F
					
6. Differential feed dog	S19247-001			S19245-001	S20244-001
					
7. Upper knife Angle knife	Angle knife S20898-101			Upper knife 144074-350	
					
8. Lower knife		S20583-001 T = 1.5		S20582-001 T = 1.5	
9. Over looper	S20438-001 G	S20429-001 Q	S20438-001 G	S20430-001 D	
					

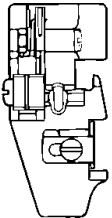
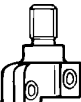
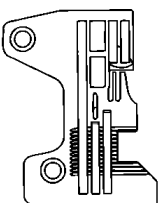
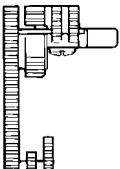
# Gauge parts list

[Models MA4-N31, V61A]

Application	3 needles thin medium	
Sub-class S=Standard H=High-lift E=Extra high-lift (mm)	99-5 H	
Needle gauge	5, 2, 2	
1. Needle (Qty)	151474-016 (3)	
2. Presser foot assy (Presser foot .F)	S31981-001 (S19325-001)	
		
3. Needle clamp assy	S29148-001	
		
4. Needle plate	S31979-001	
		
5. Main feed dog assy (Main Feed dog) (Chain feed dog)	S19226-101 (S19227-101) (S19223-101) F	
		
6. Differential feed dog	S19246-001	
		
7. Angle knife	S20896-101	
		
8. Lower knife 	S20582-001 T = 1.5	
	9. Over looper 	S20430-001 D