

JUKI®

**Direct-drive Computer-controlled Eyelet Buttonholing
Machine (with Compound Thread Trimmer)**

MEB-3200

ENGINEER'S MANUAL

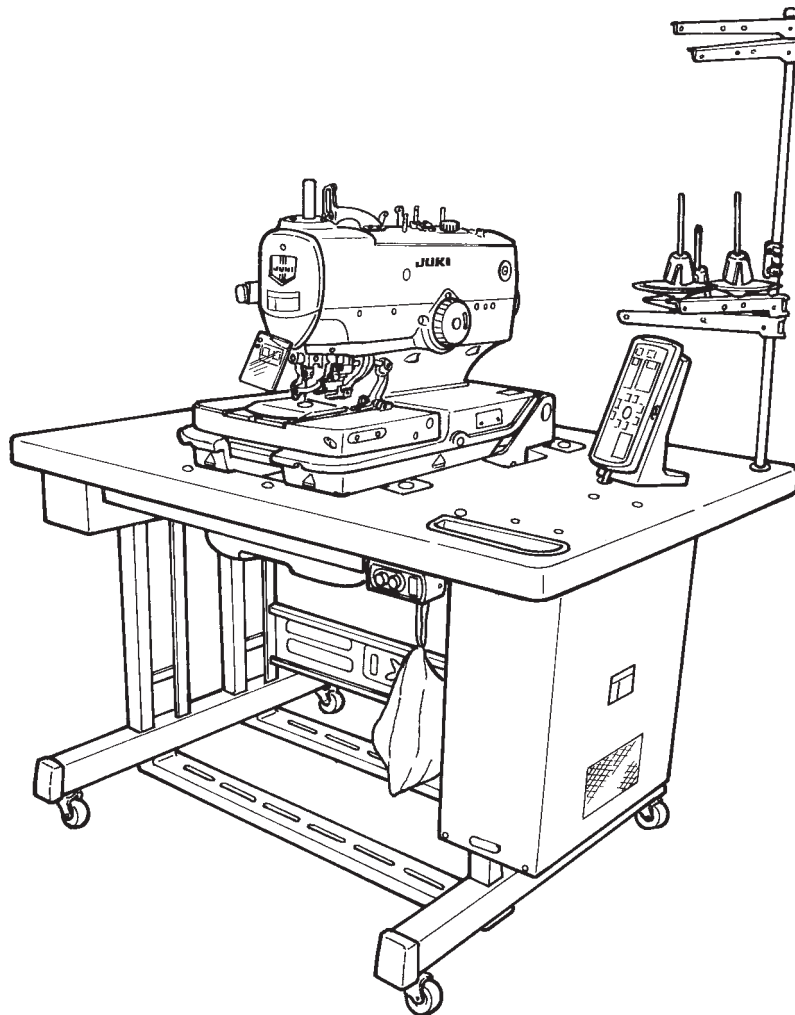

29346202
No.E345-04

PREFACE

This Engineer's Manual is written for the technical personnel who are responsible for the service and maintenance of the sewing machine. This manual describes "Adjustment Procedure", "Results of Improper Adjustment", and other functions which are not covered by the Instruction Book intended for the maintenance personnel and sewing operators at a sewing factory.

All personnel engaged in repair of MEB-3200 are required to carefully read Section 2 "Standard Adjustment" which contains important information on the maintenance of MEB-3200.

The "Standard Adjustment" consists of two parts ; the former part presents illustration and simplified explanation for the convenience of reconfirmation of the required adjustment values in carrying out actual adjustment after reading this manual once; and the latter part provides "Results of Improper Adjustment" in which sewing and/or mechanical failures, and the correcting procedures are explained for those persons who perform such adjustment for the first time.

It is advisable to use "MEB-3200 Parts Book" together with this Engineer's Manual.

CONTENTS

1. SPECIFICATIONS	1
2. NAME OF EACH COMPONENT	2
(1) Names of the sewing machine main unit	2
3. STRUCTURE OF THE OPERATION SWITCH	3
(1) Structure of the operation panel	3
(2) Temporary stop switch	5
(3) Hand switch	5
(4) Foot switch	5
4. STANDARD ADJUSTMENTS	6
(1) Adjusting the center of the needle	6
(2) Adjusting the stitch base line of the inside needle	8
(3) Adjusting the stitch bite width	8
(4) Height of the needle bar	10
(5) Timing between the needle and the looper	10
(6) Clearance between the needle and the looper	12
(7) Adjusting the needle guard	12
(8) Installation positions of the spreaders and the timing to open/close the spreaders	12
(9) Adjusting the cloth open	14
(10) Adjusting the presser	16
(11) Adjusting the knife	16
1) Adjusting the longitudinal position of the cloth cutting knife	16
2) Adjusting the lateral position of the cloth cutting knife	18
3) Adjusting the inclination of the cloth cutting knife	18
(12) Adjusting the knife holder	20
1) Adjusting the longitudinal position of the knife holder	20
2) Adjusting the lateral position of the knife holder	20
3) Adjusting the inclination of the knife holder and the backlash of the cloth cutting direct drive shaft	22
(13) Installing position of the needle thread trimming knife	24
(14) Adjusting the needle thread trimming vertical moving arm	30
(15) Adjusting the looper thread and gimp trimming	32
(16) Adjusting the short thread trimming without gimp (T type)	34
(17) Adjusting the position of the looper thread guide plate and the inclination of the counter knife (S/R types)	36
(18) Adjusting the looper thread clamp and the thread hauling (S/R types)	38
(19) Adjusting the blade pressure of the looper thread trimming knife (S/R types)	40
(20) Adjusting the short thread trimming	42
1) Initial position of the lower knife	42
2) Adjusting the stroke of the upper knife	42
3) Adjusting the knife pressure	44
4) Adjusting the position of the thread haul plate	44
5) Adjusting the position of the upper knife lower cover	46
(21) Adjusting the needle thread clamp	48
(22) Adjusting the length of remaining needle thread	50
(23) Adjusting the feeding amount of the needle thread	50
(24) Adjusting the haul amount of the looper thread (long thread trimming/short thread trimming)	52
(25) Adjusting the looper thread haul driving arm (long thread trimming)	54
(26) Adjusting the remaining amount of the gimp (J/C types)	56
(27) Adjusting the tension of the needle bar rotary timing belt	56
(28) Adjusting the tension of the looper turning timing belt	58
(29) Adjusting the position of the needle bar rotary pulley	58
(30) Adjusting the position of the looper bracket	60
(31) Adjusting the main shaft sensor	60
(32) Adjusting the origin position of the crosswise feed sensor	62
(33) Adjusting the origin position of the lengthwise feed sensor	62
(34) Adjusting the cloth cutting origin sensor	64
(35) Adjusting the backlash of the cloth cutting stepping motor	66
(36) Adjusting the cloth cutting lever stopper	66
(37) Adjusting the positions of the lengthwise feed and crosswise feed motor installing bases (Adjusting the backlash of the feed drive gear)	68
(38) Adjusting the thread take-up thread guide	68
(39) Adjusting the active tension	70
(40) Adjusting the cloth cutting knife pressure	72

5. DISASSEMBLY/ASSEMBLY	74
(1) Disassembling the needle bar driving gear	74
(2) Disassembling the needle bar arm	76
(3) Adjusting the backlash of the needle bar driving gear	76
(4) Disassembling the cloth cutting mechanism	78
(5) Installing the cloth cutting plate	78
(6) Replacing the main shaft timing belt	80
(7) Replacing the needle bar rotary upper timing belt	82
(8) Replacing the needle bar rotary lower timing belt	84
(9) Disassembling the marking light	86
(10) Fine adjustment of the laser marking projector	88
1) Adjusting the light axis of the laser marking projector	88
2) Adjusting the lateral direction of the laser marking projector	90
3) Adjusting the irradiating range of the laser beam	90
(11) Replacing the presser set	92
(12) Removing procedure of the looper thread trimming unit (When sewing beyond 38 mm)	94
6. SETTING PROCEDURE OF THE SEWING DATA	96
(1) Sewing data setting item	97
1) Compensation of the data	101
① Compensation table	102
② Thread tension compensation table	103
7. MEMORY SWITCH	105
(1) Setting the memory switch	105
(2) Initializing the memory switch	105
(3) Setting the DIP switch	105
(4) Memory switch list	106
8. TEST MODE	109
(1) Input check	109
(2) Output check	110
(3) Operation panel check	110
(4) Crosswise feed / lengthwise feed / turning origin check	111
(5) Cloth cutting knife origin check	111
(6) Sewing machine check	112
(7) Thread tension check	112
(8) Thread trimming check	112
9. ERROR LIST	113
10. REPLACING THE FUSE	114
11. CHANGING THE VOLTAGE	115
(1) Changing the voltage between 100 and 240V	115
(2) Changing the voltage between between 220 and 415V	115
12. TROUBLES AND CORRECTIVE MEASURES.....	116
13. AIR PIPING DIAGRAM.....	120
14. CIRCUIT DIAGRAM	121
(1) Connector circuit board wiring diagram	121
(2) Main circuit board wiring diagram	121
(3) Block diagram (1) 1 / 2	122
(4) Block diagram (2) 1 / 2	124
(5) Block diagram (3) 1 / 2	126
(6) Stepping motor circuit diagram	128
(7) Sensor circuit diagram	129
(8) Power source circuit diagram 100V, 200V	130
(9) Power source circuit diagram 380V	131
(10) Solenoid valve curcuit diagram	132
(11) Active tension curcuit diagram	133
(12) Servo motor circuit diagram	134
15. MULTICUTTING DEVICE	135

1. SPECIFICATIONS

Item	S type, R type	J type	C type	T type
Application	Men's and ladies' wear	Jeans	Cotton pants, working wear	Slacks
Sewing speed	400 to 2,200 rpm (adjustable in 100 rpm steps)			
Thread trimming type	Long thread trimming	Short thread trimming		Short thread trimming without gimp
Stitch length (Caution 1)	10 to 38 mm (with looper thread trimmer) 10 to 50 mm (In case looper thread trimming device is removed)	24 to 32 mm (Standard) * For the shapes of taper bar and without bar-tacking, up to 34 mm	16 to 24 mm (Standard) * For the shapes of taper bar and without bar-tacking, up to 26 mm	Compensating foot S : 16 to 24 mm (Standard) 10 to 34 mm
Stitch bite width (Caution 2 and 3)	2.0 to 3.2 mm	2.0 to 4.0 mm	2.0 to 3.2 mm	
Taper bar length	0 mm, 3 to 15 mm			
Lift of presser foot	13 mm (Max. 16 mm)			
Method of changing sewing shape	Program selection method			
Buttonhole cutting system	Cut-before knife, cut-after knife, without knife			
Feed system	Intermittent feed by stepping motor			
Cloth cutting drive	Vertical drive by stepping motor (Pressure can be adjusted.)			
Needle (Caution 2)	DOX558 #90 to 110	DOX558 #90 to 110	DOX558 #110 to 120	DOX558 #100 to 110
Safety device	Temporary stop switch and automatic stop function at the time of detection of trouble			
Lubricating oil	JUKI New Defrix Oil No. 2 (Equivalent to ISO VG32)			
Air pressure	0.49 Mpa			
Air consumption	6 ℓ / min (8-cycle/min)			
Dimensions	1,060 mm (W) X 790 mm (L) X 1,230 mm (H) (Excluding thread stand)			
Power consumption	550 VA			
Gross weight	185 kg			
Noise	Workplace-related noise at sewing speed n=2,000min ⁻¹ : L _{PA} ≤ 81.5 dB (A) Noise measurement according to DIN 45635-48-B-1.			

Caution 1 : For the short thread trimming type, stitch length can be changed by changing the optional presser set.

S set : 16 to 24 mm, M set : 24 to 32 mm, L set : 32 to 40 mm

(26) *

(34) *

(42) *

* In case of taper bar and without bar-tacking

Caution 2 : Stitch bite width and needle size at the time of delivery are as follows.

	S and R types	J type	C type	T type
Stitch bite width	2.8 mm (Domestic), 2.3 mm (Export)	3.6 mm (Domestic), 2.5 mm (Export)	2.5 mm	2.3 mm
Needle size	#100	#110 (Domestic), #120 (Export)	#110	#100

(When changing stitch bite width or needle size, check installing position and open/close timing of needle, looper, and spreader, and clearance between needle and needle guard.)

Caution 3 : By changing to the optional looper, left and spreader left, the range of stitch bite width can be changed from 2.0 to 3.2 mm → 2.6 to 4.0 mm. (S/J/C types only excluding T type)

Caution 4 : In case of the machine with needle thread clamp device and multicutting device, read the Instruction Manuals for the respective devices together with this Engineer's Manual.

Caution 5 : For T (slacks) type, sewing with gimp cannot be performed. In addition, the presser foot is provided with S set which is adaptable to the extent of stitch length of 24 mm.

2. NAME OF EACH COMPONENT

(1) Names of the sewing machine main unit

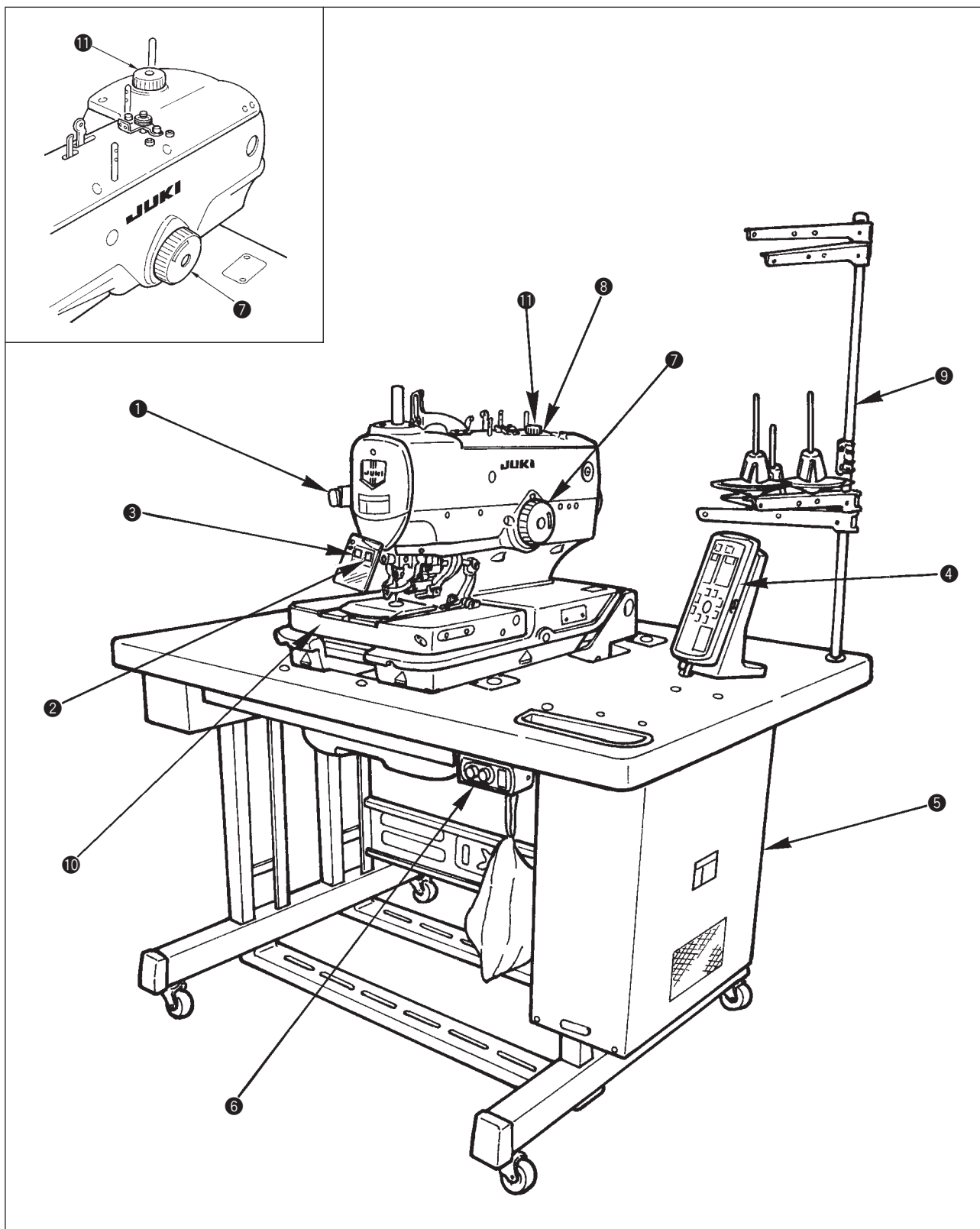

① Temporary stop switch

② Presser switch

③ Start switch

④ Operation panel

⑤ Control box

⑥ Power switch

⑦ Hand pulley

⑧ Machine head

⑨ Thread stand

⑩ Feed base







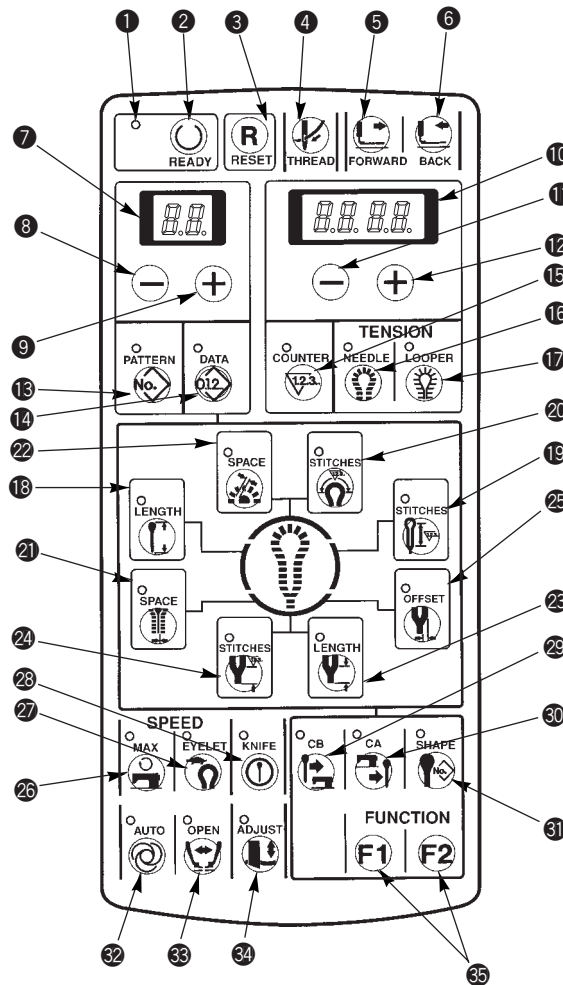

⑪ Cloth cutting dial



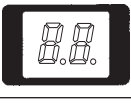

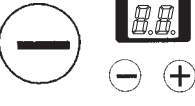

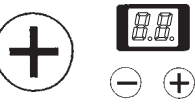

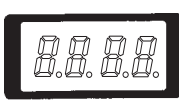

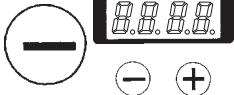













3. STRUCTURE OF THE OPERATION SWITCH

(1) Structure of the operation panel



[Table of functions of the operation panel]

No.	Name	Description	No.	Name	Description
1	Sewing LED 	This LED lights up when the sewing machine can be operated.	6	BACK key 	When this key is pressed, the feed mechanism travels backward stitch by stitch.
2	READY key 	Setting \longleftrightarrow sewing ready can be changed over alternately every time this key is pressed.	7	2-digit LED 	This LED displays pattern No. normally. Data No. is displayed at the time of data setting.
3	RESET key 	Error release (at the time of various errors) Reset of the production counter Move of the feed setting position Release of the threading mode	8	LEFT “-” key 	This key subtracts pattern No. or data No.
4	THREAD key 	Needle bar rotates when this key is pressed and the mode becomes the threading mode. (See Instruction Manual, p.16.) (When the sewing LED lights up.)	9	LEFT “+” key 	This key adds pattern No. or data No.
5	FORWARD key 	When this key is pressed, the feed mechanism travels forward stitch by stitch.	10	4-digit LED 	This LED displays cut length, contents of data setting, counter value, error No., etc.

NO.	Name	Description	NO.	Name	Description
11	RIGHT “-” key 	This key subtracts various data.	23	LENGTH (Taper bar length) key Note 1 	This key sets sewing length of taper bar. Note 1
12	RIGHT “+” key 	This key adds various data.	24	STITCHES (Number of stitches of taper bar) key 	This key sets the number of stitches of taper bar. Note 1
13	PATTERN key 	This key performs display and setting of pattern No.	25	OFFSET (Taper bar offset) key 	This key sets the slip amount of taper bar. Note 1
14	DATA key 	This key performs display and setting of DATA No.	26	MAX (Sewing speed) key 	This key performs setting of sewing speed. Note 1
15	COUNTER key 	This key performs display and setting of counter.	27	EYELET (Eyelet speed setting) key 	This key performs setting of reduced speed at eyelet section. Note 1
16	NEEDLE key 	This key performs display and setting of needle thread tension data.	28	KNIFE (Knife ON/OFF)key 	This key sets effective/ ineffective of knife. Note 3
17	LOOPER key 	This key performs display and setting of looper thread tension data.	29	CB (Before-cut knife) key 	This key performs data setting of before-cut knife. Note 2
18	LENGTH key 	This key sets the length to be sewn. Note 1	30	CA (After-cut knife) key 	This key performs data setting of after-cut knife. Note 2
19	STITCHES (Number of stitches of parallel) key 	This key sets the number of stitches of the parallel section. Note 1	31	SHAPE (Knife No.) key 	This key selects the No. of kind of knife to be used. Note 1
20	STITCHES (Number of stitches of eyelet) key 	This key sets the number of stitches of the eyelet section. Note 1	32	AUTO (Auto operation) key 	This key performs change-over of automatic and manual operation modes.
21	SPACE (Cut space) key 	This key sets clearance between cloth cutting knife and sewing at the parallel section. Note 1	33	OPEN (Cloth open) key 	The mode becomes the one operating with the cloth open mechanism opened.
22	SPACE (Eyelet space) key 	This key sets clearance between cloth cutting knife and sewing at the eyelet section. Note 1	34	ADJUST (Knife adjust) key 	The mode becomes the one of cloth cutting knife adjustment by turning ON the power with this key held pressed.
			35	FUNCTION (Function) key 	This key can be changed to optional data setting function key with the memory switch. At the time of delivery F1 : Knife position adjustment (No. 8) F2 : Copy destination No. (No. 80)

Note 1 : When changing the set value, operate the panel in the state that the sewing LED has gone out.

Note 2 : When both the before-cut and after-cut knives are not selected (set value : “0”), the data without knife is selected.

Note 3 : Effective / ineffective of knife operation can be selected in case of the before-cut and after-cut knives, however, in case of the data without knife, the knife operation cannot be performed.

(2) Temporary stop switch

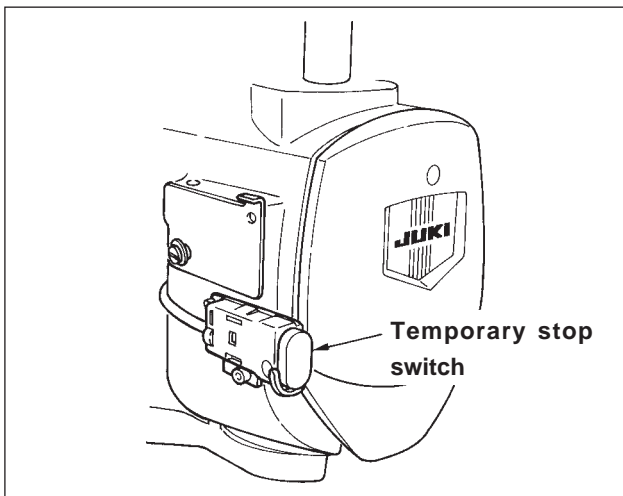

This switch stops the operation of the sewing machine.

(3) Hand switch

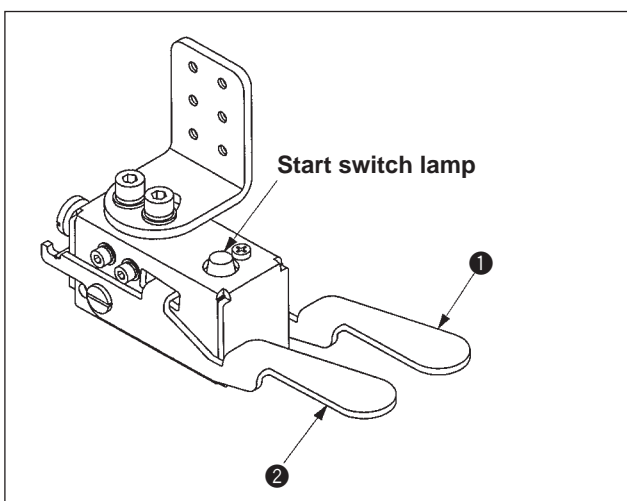

- 1) Presser switch (right) ①
 - This switch performs up/down of the presser.
- 2) Start switch (left) ②
 - This switch performs the start of sewing.
 - When the start switch is effective, the start switch lamp flashes on and off.
 - This switch is provided as standard.

(4) Foot switch

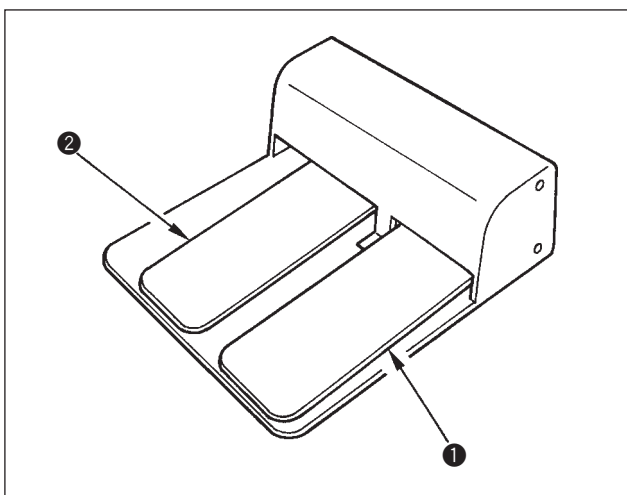

- 1) Presser switch ①
 - This switch performs up/down of the presser.
- 2) Start switch ②
 - This switch performs the start of sewing.
 - This switch is optional.

4. STANDARD ADJUSTMENTS

(1) Adjusting the center of the needle

Standard Adjustment

① Clearance between the needle and the left looper

<p>Needle</p> <p>Left Looper</p> <p>0.03 to 0.1</p>	<p>0.03 to 0.1</p>	<p>0.03 to 0.1</p>	<p>0.03 to 0.1</p>
Sewing start side	Eyelet buttonhole section	Sewing end side	Straight bar side

② Timing between the needle and the left looper

<p>To align the center</p>	<p>To align the center</p>	<p>To align the center</p>	<p>To align the center</p>
Sewing start side	Eyelet buttonhole section	Sewing end side	Straight bar side

Adjustment Procedures	Results of Improper Adjustment
<ul style="list-style-type: none"> ○ Make sure that the clearance and timing between the needle and the looper are equal at the time of occurrence of stitch skipping and disassembling/assembling the needle bar. If they are not equal, perform the adjustment described below. 1. Loosen three setscrews ❶ in the needle bar cover and remove the needle bar cover. 2. Turn the hand pulley to align the left looper with the center of the needle. 3. Turning the looper bracket by hand, check the figure on the left side (4 places). 4. Loosen three setscrews ❸ in needle bar upper metal ring holder ❷ and move needle bar ❹ back and forth, and left to right to adjust so that the clearance and timing should be equal. 	<ul style="list-style-type: none"> ○ Stitch skipping occurs at parallel section and eyelet section at the time of going and back of the looper.

(2) Adjusting the stitch base line of the inside needle

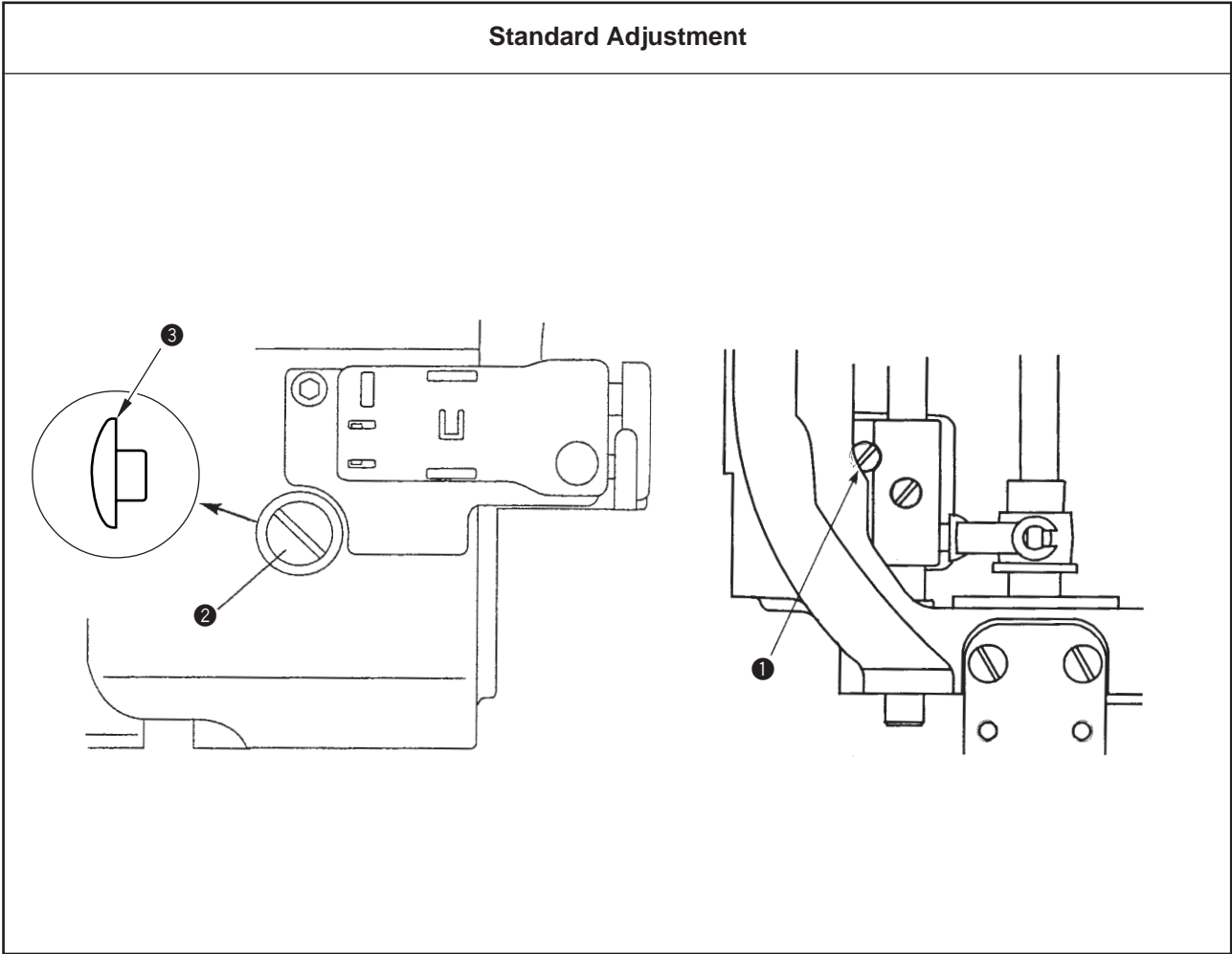

(3) Adjusting the stitch bite width

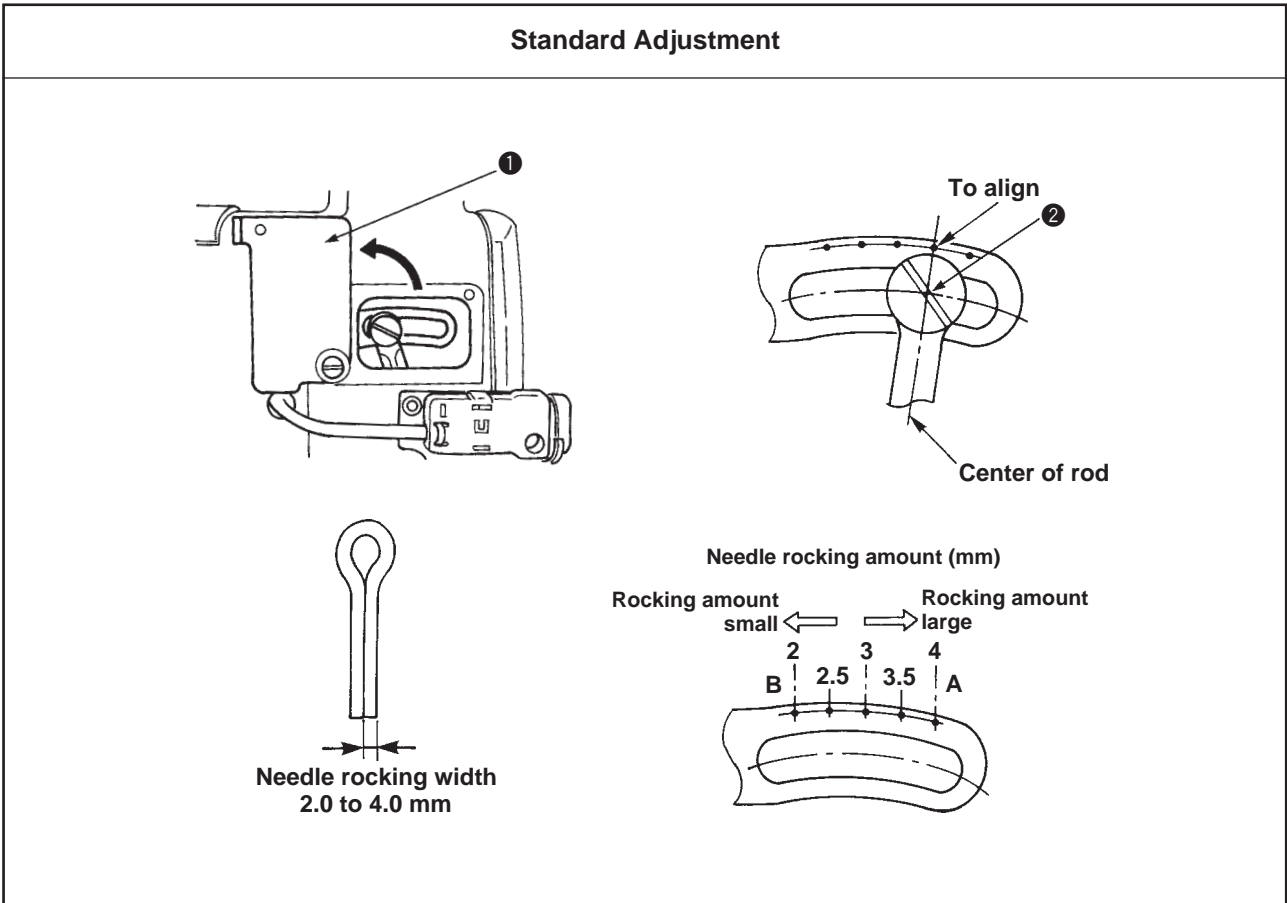

Adjustment Procedures	Results of Improper Adjustment
<ol style="list-style-type: none"> 1. Remove the cloth cutting knife and plug ③. 2. Turn ON the power to the machine, press the auto key to change over to the manual operation mode, and press the ready key to set the manual state. 3. Lower the presser with the presser switch. At this time, place a piece of paper on the throat plate to check the needle entry position of the inside needle. 4. Keep pressing the forward key and stop it at the position of the sewing start. 5. Turn the hand pulley and make the mark of the needle entry position on the paper. Then return the needle bar to the up-position (inside needle side). 6. Again, keep pressing the forward key to move to the position of the sewing end and turn the hand pulley to make the mark of the needle entry position on the paper. 7. When the needle entry positions (inside) are not aligned with each other, loosen screw ① in the rocking link B and turn rocking link B eccentric shaft ② to align them. 8. Press the reset key to return to the set position. <p>(Caution) When adjustment of the stitch base line is performed, be sure to check “(5) Timing between the needle and the looper and (6) Clearance between the needle and the looper”.</p>	

Adjustment Procedures	Results of Improper Adjustment
<ol style="list-style-type: none"> 1. Open stitch width adjust cover ①. 2. Turn the handwheel to bring the needle bar to its lower dead position. 3. Loosen rocking link B fulcrum shaft ②. 4. When the stitch bite width is determined, fix rocking link B fulcrum shaft ② and close the stitch width adjust cover. 5. When the stitch bite width has been adjusted through the aforementioned steps, be sure to check the items “(5) Timing between the needle and the looper, (6) Clearance between the needle and the looper, and (8) Installation position of the spreaders and the timing to open/close the spreaders”. 6. After changing the stitch bite width, re-set the set values of the memory switch and the sewing data. (Memory switch : needle rocking width, Sewing data : Nos. 17, 18 and 19) <p>(Caution) The engraved marker dot is the standard of the needle rocking width. To be correct, measure the stitch bite width by dropping the needle tip on a sheet of paper or the like.</p>	<ul style="list-style-type: none"> ○ When moving the fulcrum shaft in the direction A, the stitch bite width is increased. ○ When moving the fulcrum shaft in the direction B, the stitch bite width is decreased.

(4) Height of the needle bar

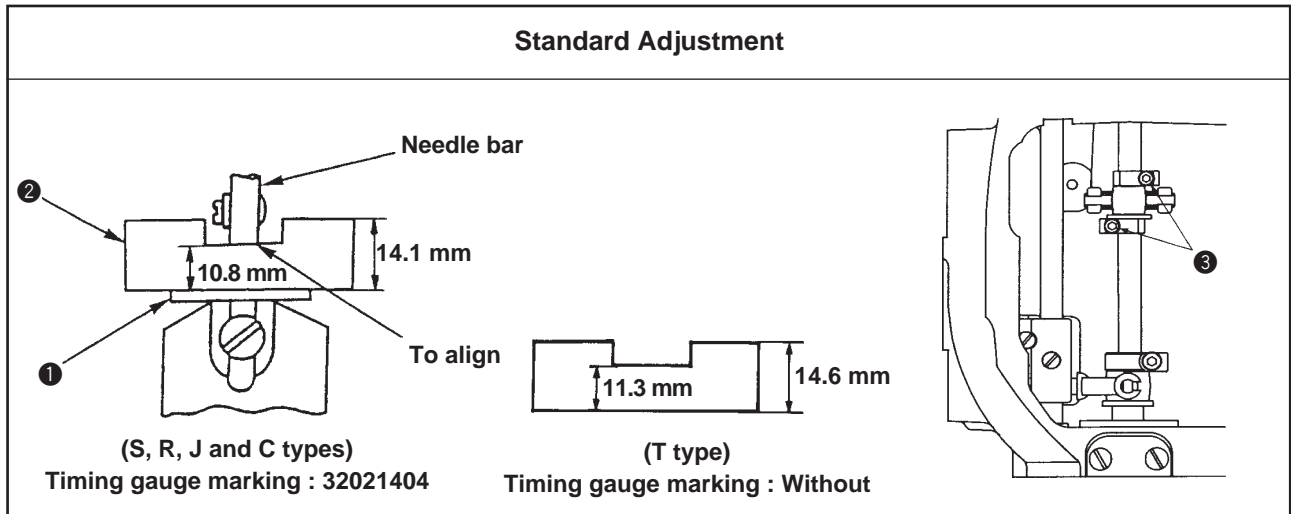

(5) Timing between the needle and the looper

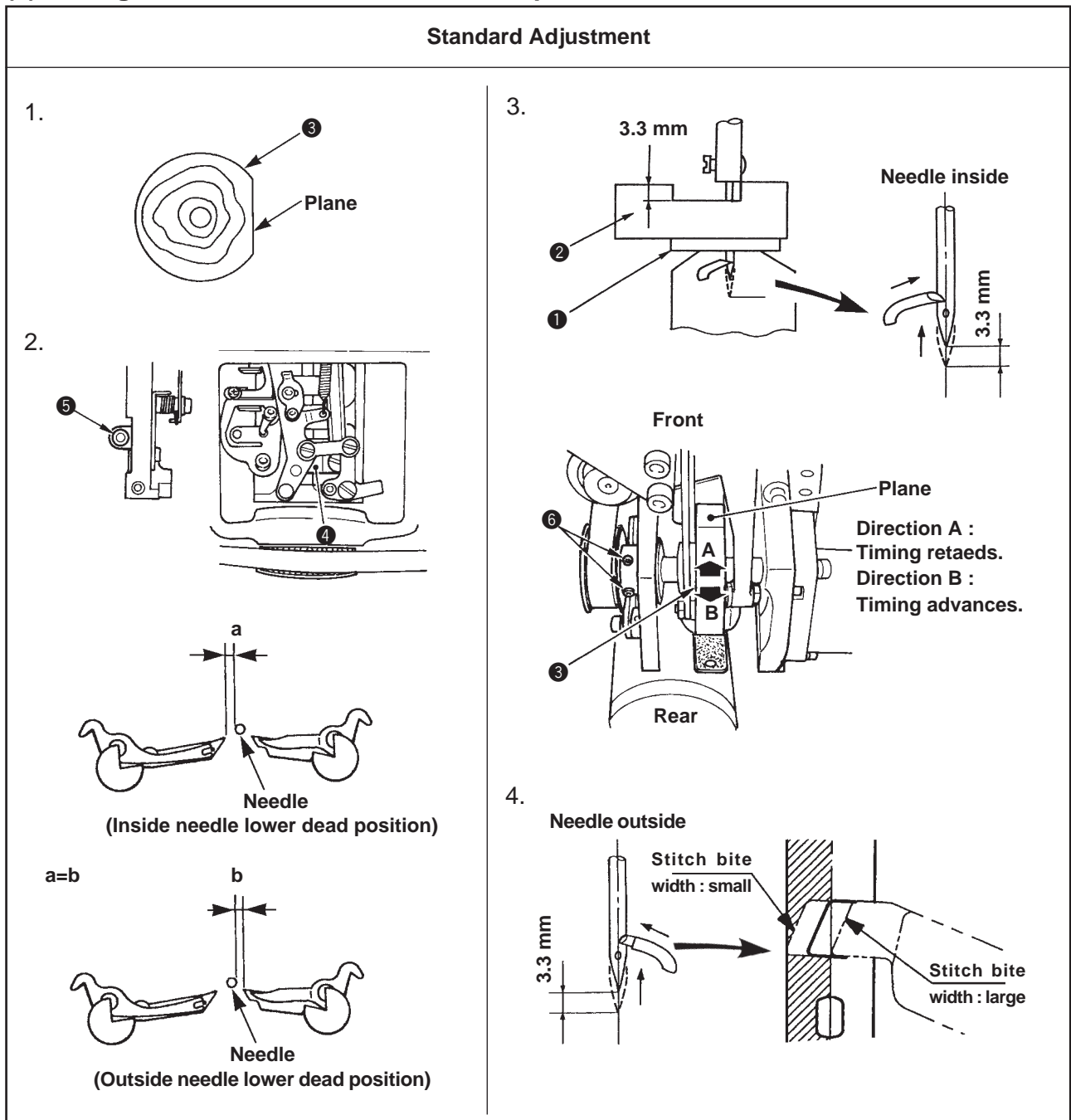

Adjustment Procedures	Results of Improper Adjustment
<ol style="list-style-type: none"> 1. Remove the throat plate. Instead of the throat plate, attach timing gauge support base ① supplied with the machine on the machine. 2. Place timing gauge ② supplied with the machine on timing gauge support base ①, loosen setscrew ③, and move the needle bar up or down to adjust so that the needle bar aligns with the indented part of the timing gauge when the needle bar is in the inside needle lower dead position. <p>(Caution) There are two kinds of timing gauges ②. (Select the gauge according to the type.)</p>	<ul style="list-style-type: none"> ○ When the needle bar is higher or lower than the specified position, stitch skipping occurs in both cases.

Adjustment Procedures	Results of Improper Adjustment
<ol style="list-style-type: none"> 1. Bring the needle bar to the inside needle lower dead position, loosen lower shaft sprocket setscrews ⑥ and move looper driving cam ③ so that the plane of looper driving cam ③ faces to the front. Then temporarily tighten the screws. 2. Loosen looper driving shaft guide setscrew ⑤ and move up and down looper driving shaft guide ④ to adjust so that the space between the needle and the left/right loopers becomes the same when the needle bar is brought to the inside needle lower dead position or the outside needle lower dead position. 3. Place timing gauge ③ on timing gauge support base ② and adjust using looper driving cam ③ so that the left looper blade point is aligned with the center of needle when the needle bar ascends 3.3 mm from the inside needle lower dead position, and fix lower shaft sprocket setscrews ⑥. 4. Make sure of the position of needle and looper blade point when the needle bar ascends 3.3 mm from the outside needle lower dead position. The blade point is approximately in the range of the left side of needle. In case of outside of the range, adjust again steps 2. and 3.. <p>(Caution) Be sure to perform the confirmation and re-adjustment when the stitch bite width is changed.</p>	<ul style="list-style-type: none"> ○ The right looper advances when the looper driving shaft guide is lifted in the upper direction. ○ The right looper delays when the looper driving shaft guide is lowered in the lower direction.

(6) Clearance between the needle and the looper

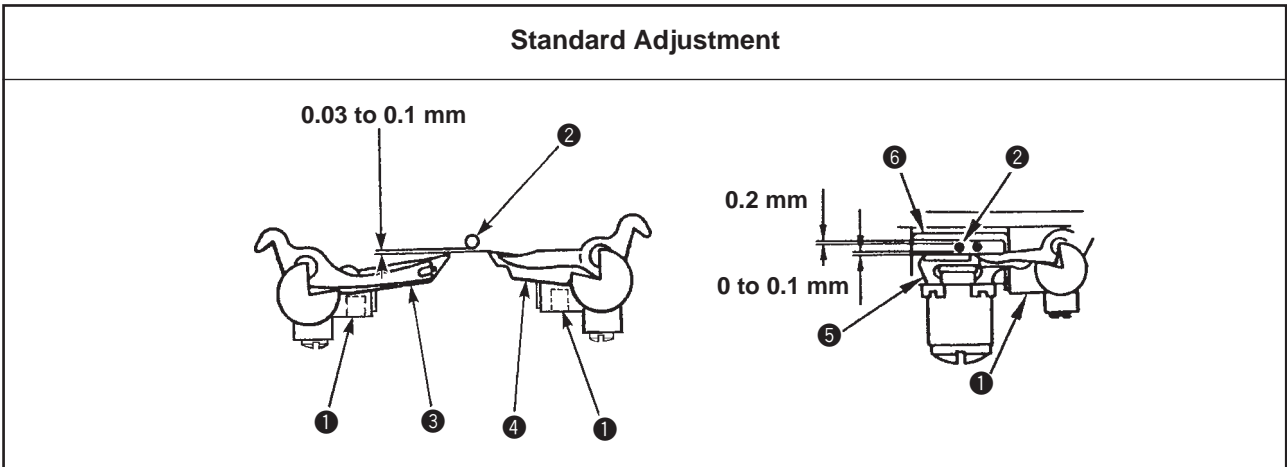

(7) Adjusting the needle guard

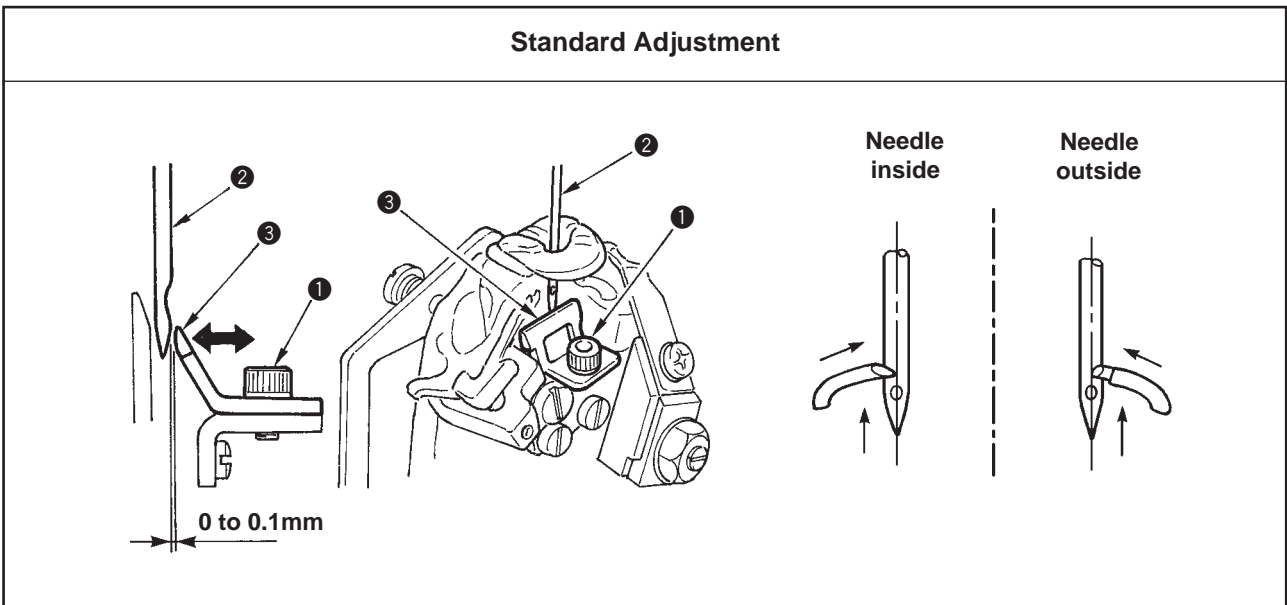

(8) Installation positions of the spreaders and the timing to open/close the spreaders

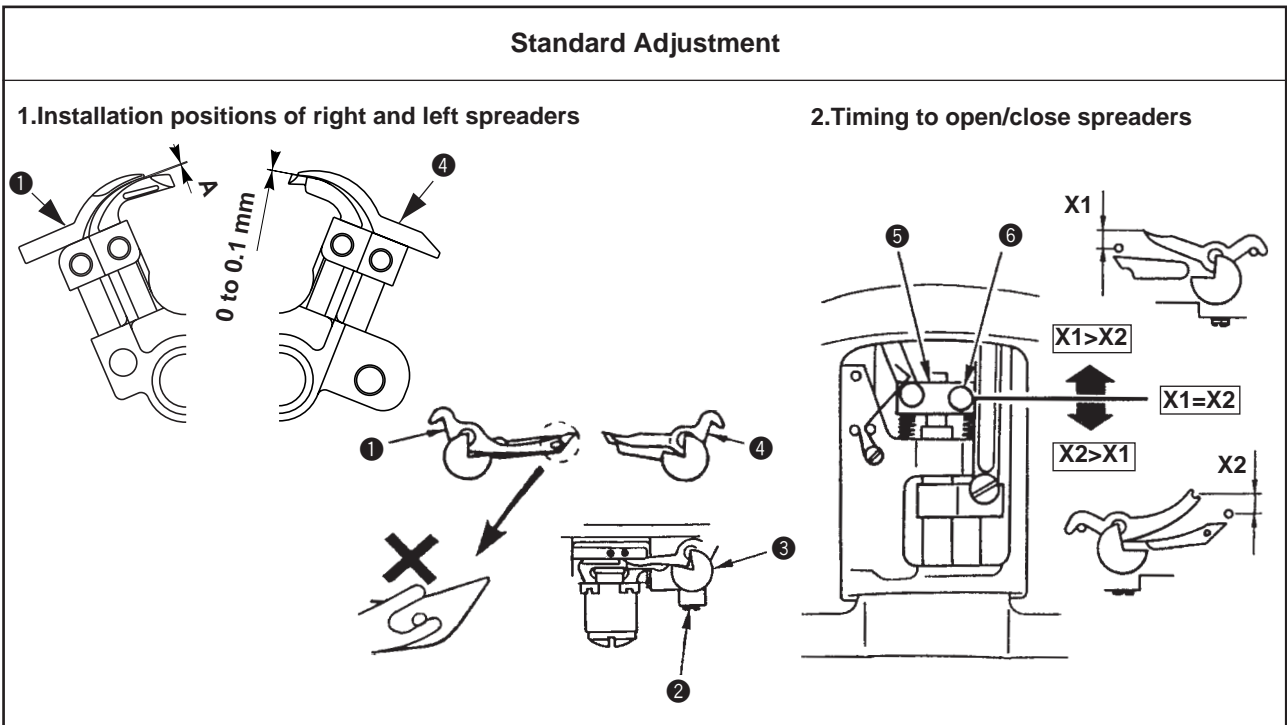

Adjustment Procedures	Results of Improper Adjustment
<p>The standard adjustment value of the clearance between the needle and the looper is 0.03 to 0.1 mm.</p> <p>Loosen looper setscrew ① and adjust the clearance between needle ② and left looper ③, and between the needle and right looper ④.</p> <p>Dimensions for reference Clearance between the needle and needle guard ⑤ : 0 to 0.1 mm Clearance between the needle and holder ⑥ : 0.2 mm</p> <p>(Caution) Be sure to adjust the clearance when the needle size is changed.</p>	<ul style="list-style-type: none"> ○ When the clearance is larger than the specified value, stitch skipping may occur.

Adjustment Procedures	Results of Improper Adjustment
<ol style="list-style-type: none"> 1. Provide a clearance of 0 to 0.1 mm between needle ② and needle guard ③. 2. Loosen setscrew ① and move needle guard ③ back and forth to adjust the clearance. 3. Tighten setscrew ①. 4. Check the clearance both at the time of inside needle and outside needle. <p>(Caution) 1. Be sure to adjust the needle guard when the needle size is changed or when the adjustment of needle and looper is performed.</p> <p>2. Adjust the clearance when needle aligns with the looper blade point at the time of the inside needle and outside needle respectively.</p>	

Adjustment Procedures	Results of Improper Adjustment
<ol style="list-style-type: none"> 1. Installation position of left and right spreaders <ol style="list-style-type: none"> 1) Clearance A between left spreader ① and the top surface of left looper is as large as a piece of looper thread used. 2) The center of the top end of forked section of Left spreader ① agrees with the center of looper thread hole of left looper. 3) Clearance between right spreader ④ and the top surface of right looper is 0 to 0.1 mm. 4) Right spreader ④ agrees with the right spreader and the crest line of the inside of right looper (needle side). 5) Loosen setscrew ② in the spreader stopper and adjust the position of spreader stopper ③ to fix the spreader. (Make the same adjustment for both left/right spreaders.) 2. Timing to open/close the spreaders <ol style="list-style-type: none"> 1) Adjust so that the spreaders open/close equally on the left and right without interfering with the needle. 2) Loosen setscrew ⑥ in spreader driving shaft guide ⑤ and move the guide up and down to make the adjustment. 	<ul style="list-style-type: none"> ○ When closing timing of the left spreader is delayed, stitch skipping may occur. (Loop becomes small when the outside needle catches thread.) ○ When the clearance between spreader and looper is smaller or larger than the specified value, stitch skipping or needle breakage will be caused. <p>(Caution) Adjust the clearance by correcting the spreader. Using the cutting pliers or the like causes breakage of the spreader. Put a piece of wooden board or the like on the top end of spreader and gradually bend it by hand.</p>

(9) Adjusting the cloth open

Standard Adjustment

When the presser plate is open, clearance A between presser plate ⑧ and the corner section of feed base ⑨ is 1 mm.

When the presser plate is closed, clearance B between presser plate ⑧ and the corner section of feed base ⑨ is 1.5 mm.

At this time, the cloth opening amount is : $1.5 \text{ mm} - 1 \text{ mm} = 0.5 \text{ mm}$.

(Caution) Adjust so that the cloth opening amount (B - A) should be equal in the left and right sides.

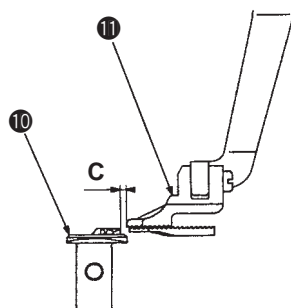
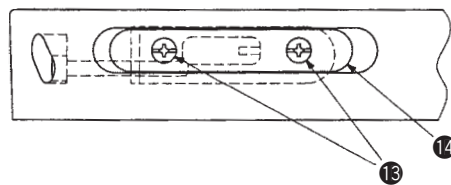
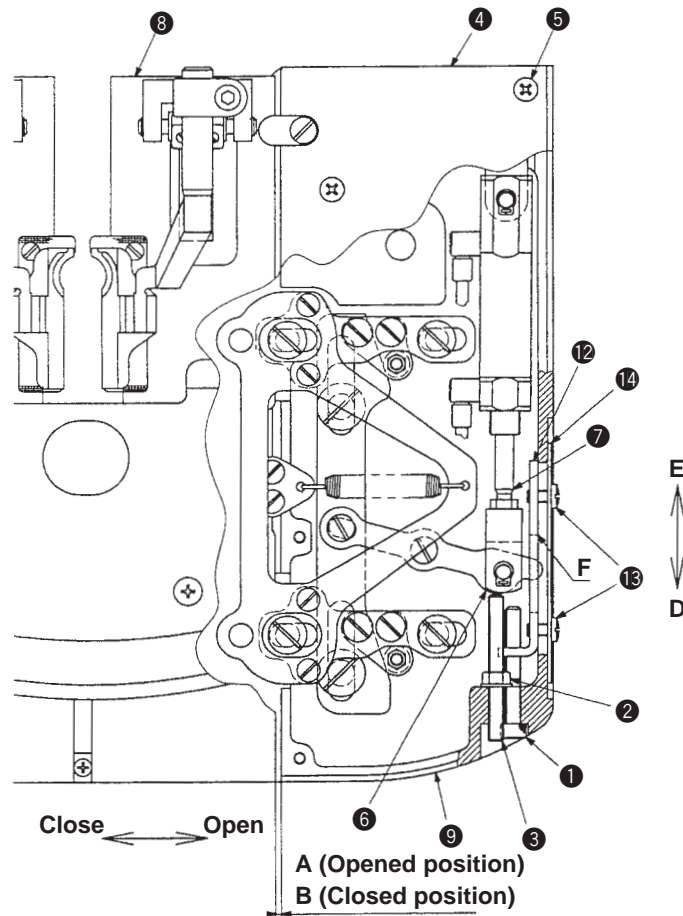

Adjustment Procedures	Results of Improper Adjustment
<p>1. Position where the presser plate is open (Position at the time of sewing)</p> <ol style="list-style-type: none"> 1) Loosen setscrew ⑤ and remove auxiliary cover ④. 2) Turn ON the power and press the ready key to light up the sewing LED. 3) Press the knife ON/OFF key to make the LED go out and the cloth cutting knife inoperative. 4) Press the presser switch (presser comes down), press the forward key and cloth open cylinder ⑦ is turned ON (Arrow mark D). Then the presser plate will open. (Cloth open driving link ⑥ comes in contact with adjusting screw ③.) 5) Loosen nut ②, and turn adjusting screw ③ to adjust so that position A where the presser plate is open to 1 mm. Turning adjusting screw ③ clockwise makes clearance A smaller or turning it counterclockwise makes clearance A larger. 6) After adjusting clearance A, fix nut ②. <ul style="list-style-type: none"> * 1. Position A where the presser plate is open which has been adjusted in step 5) becomes the position of presser foot ⑪ in terms of throat plate ⑩. Consequently, in the case where you desire to retain the place near the outside needle of the sewing pattern with the presser foot, make clearance A larger to make smaller clearance C between throat plate ⑩ and presser foot ⑪. In this case, clearance C between throat plate ⑩ and presser foot ⑪ is required to be large due to the closing amount (= cloth opening amount) described in "2. Position where the presser plate is closed" below. * 2. The range of mechanical adjustment of clearance A is approximately 0 to 3 mm in the state of standard delivery. However, it is necessary to consider the aforementioned * 1. <p>2. Position where the presser plate is closed (Initial position)</p> <ol style="list-style-type: none"> 1) After performing adjustment of the aforementioned "1. Position where the presser plate is open" (or after confirming clearance A), press the reset key. Cloth open cylinder ⑦ is turned OFF (arrow mark E) after the presser has been raised, and the presser plate will be closed. (Cloth open driving link ⑥ comes in contact with the slot F of stopper ⑫.) 2) Loosen two setscrews ⑬, turn adjusting screw ① and adjust position B where the presser plate is closed to 1.5 mm. When turning adjusting screw ① clockwise, stopper cover ⑭ moves in direction D and clearance B becomes larger. When turning it counterclockwise, stopper cover ⑭ moves in direction E and clearance B becomes smaller. 3) The closing amount subtracted clearance A of the aforementioned 1.-5) from this clearance B is the cloth opening amount. B - A = cloth opening amount 4) Fix two setscrews ⑬ and further tighten adjusting screw ①. <ul style="list-style-type: none"> * 3. The range of the mechanical adjustment of clearance B is approximately 0 to 3 mm in the state of the standard delivery. However, it is necessary to consider the aforementioned * 1. 	<ul style="list-style-type: none"> ○ If clearance A is excessively large, needle or throat plate and presser foot or eyelet holding plate will interfere with each other. As a result, stitch failure or damage of throat plate will be caused. ○ If clearance A is excessively small, particularly in case of high-shrinkable fabric, flopping occurs, causing stitch skipping or uneven stitching. <ul style="list-style-type: none"> ○ If clearance B is excessively small, clearance C between throat plate and eyelet holding plate cannot be obtained, causing the damage of throat plate. ○ If the cloth opening amount (B - A) is made small, the right and left overedging will be overlapped with each other, causing the stitch failure. ○ If the cloth opening amount (B - A) is made large, the fabric is pulled more than required, and not equally opened to the right and left. As a result, deformation of sewing pattern will occur. ○ If the cloth opening amount (B - A) is not equal on the right and left sides, the fabric moves to one side. As a result, deformation of sewing pattern will occur.

(10) Adjusting the presser

Standard Adjustment

(Lateral position of the presser foot)

The edge of presser foot ① is aligned with the edge of eyelet holding plate ② (0 to 0.5 mm).

(Longitudinal position of the presser foot)

The arc section of presser foot ① is aligned with the arc section of the eyelet holding plate ②. (The centers of each arc are aligned with each other.)

(Inclination of the presser foot)

Bottom surface of presser foot ① should come in full contact with the knurled top surface of eyelet holding plate ②.

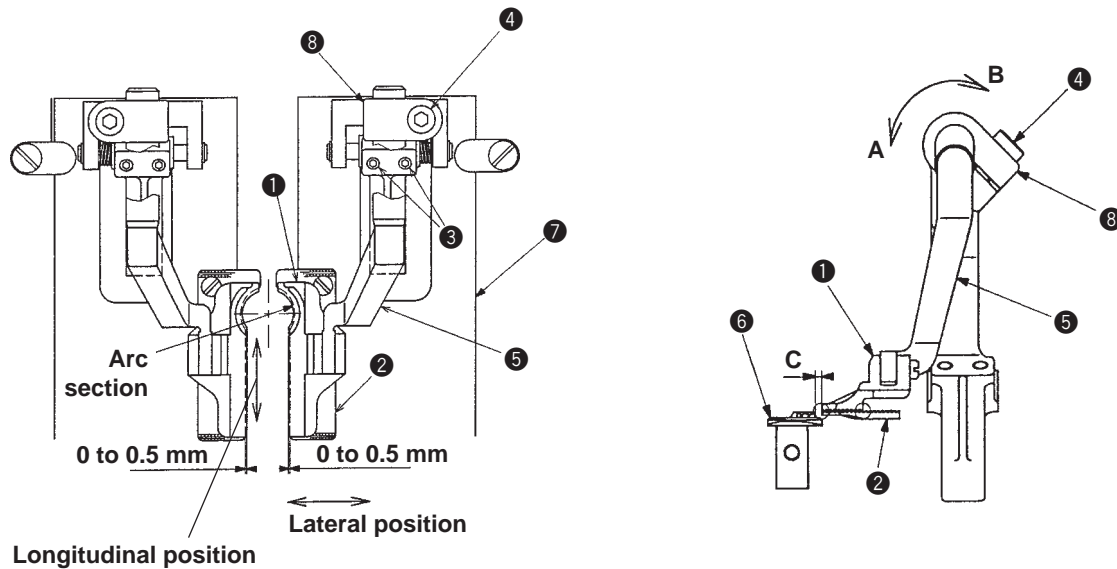

(11) Adjusting the knife

Standard Adjustment

1) Adjusting the longitudinal position of the cloth cutting knife

At the time of SS/RS types

Adjust the position so that the distance between the top of the eyelet section and the center of the needle bar is 64 mm when the cloth is cut. (As a substitute characteristic, the desired value can be obtained when adjusting the distance between the edge of the stopper section of knife stopper ① and the center of the needle bar to 65.5 mm.)

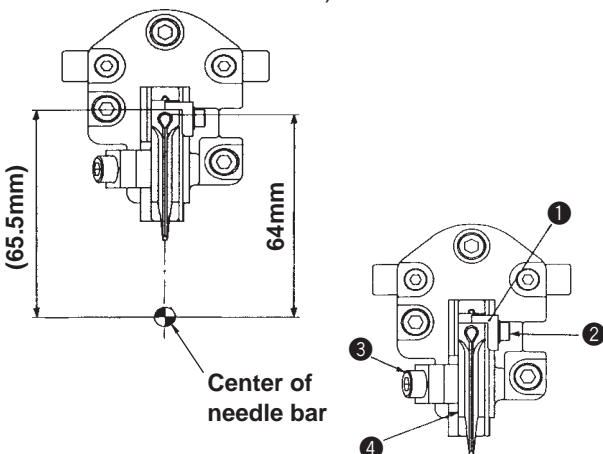

At the time of JS/CS/TS types

Adjust the position so that the distance between the top of the eyelet section and the center of the needle bar is 54 mm when the cloth is cut. (As a substitute characteristic, the desired value can be obtained when adjusting the distance between the edge of the stopper section of knife stopper ① and the center of the needle bar to 55.5 mm.)

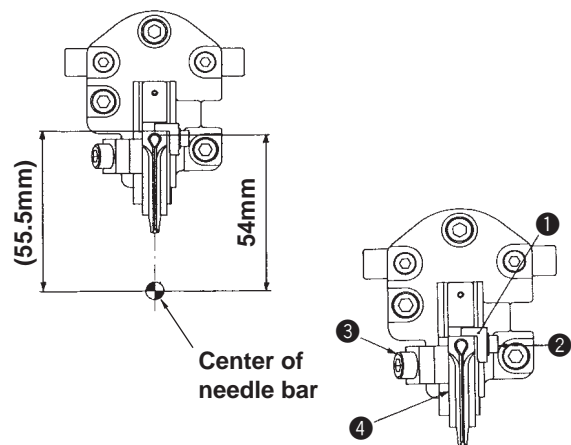

Adjustment Procedures	Results of Improper Adjustment
<p>1. Position where the presser plate is open (position at the time of sewing)</p> <ol style="list-style-type: none"> 1) Remove presser plate ⑦ from the feed base. 2) Loosen screw ④, turn presser arm ⑤ in the direction of arrow mark A or B, and adjust so that the bottom surface of presser foot ① comes in uniform contact with the knurled top surface of eyelet holding plate ②. 3) At the same time, move presser arm ⑤ and adjust the longitudinal position of presser foot ①. 4) Tighten screw ④ and fix presser arm ⑤. 5) Loosen two screws ③, move presser arm base ⑧ to the left or right and adjust so that the edge of presser foot ① is aligned with the edge of eyelet holding plate ② (0 to 0.5 mm). 6) Tighten two screws ③ and fix presser arm base ⑧. 7) Set the presser plate onto the feed base and confirm the position of the presser plate in terms of needle and throat plate in the manual mode. <p>* 1. If the presser pressure is high and the sewing product is thin, the edge (needle) side of presser foot ① is likely to rise. In this case, twist the presser foot in the direction of arrow mark A so that the edge side is slightly lowered in the aforementioned step 2).</p> <p>* 2. See the Instruction Manual for the adjustment of the presser pressure and the height of the presser.</p> <p>(Caution) In case of floppy fabric, when making presser foot ① come near throat plate ⑥, be sure to check the position of the presser foot in terms of needle and throat plate. In addition, when checking the position, perform and check opening/closing of the cloth open mechanism.</p>	<ul style="list-style-type: none"> ○ When the presser is tilted, the fabric is not uniformly pressed. As a result, deformation of sewing pattern or stitch skipping will be caused. In addition, a partial presser pressure is applied and the cloth open mechanism does not work well. As a result, deformation of sewing pattern or the like will be caused. ○ When the longitudinal or lateral position of the presser foot is improper, interference of needle with throat plate occurs. As a result, needle breakage, damage of parts, irregular stitches, etc. will be caused.

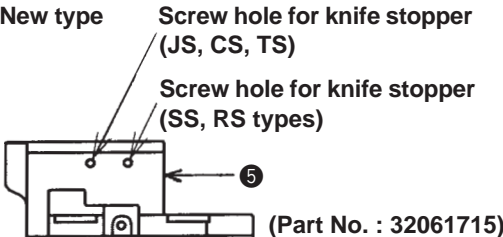
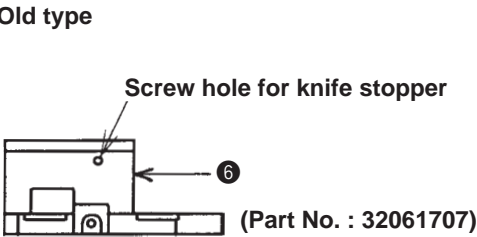
Adjustment Procedures	Results of Improper Adjustment
<p>1) Adjusting the longitudinal position of the cloth cutting knife</p> <ol style="list-style-type: none"> 1. Loosen knife stopper setscrew ②. 2. Loosen knife fixing plate setscrew ③, and adjust the position of cloth cutting knife ④ so that the portion where cloth cutting knife ④ comes in contact with knife stopper ① is 65.5mm (SS/RS types) or 55.5 mm (JS/CS/TS types) away from the center of the needle bar, and tighten knife fixing plate setscrew ③. 3. Press knife stopper ① against cloth cutting knife ④ and tighten knife stopper setscrew ② to fix the knife stopper. <p>(Caution)</p> <ol style="list-style-type: none"> 1. Note that there are new type ⑤ and old type ⑥ of the cloth cutting knife base. 2. In case of SS/RS types and JS/CS/TS types, the respective positions of knife stopper ① of new type cloth cutting knife base ⑤ are different from each other. 3. When the cloth cutting knife base is old type ⑥, adjust the position to 64 mm from the center of the needle bar. (Object of sewing type : SS/RS/JS) <div style="display: flex; justify-content: space-around; align-items: flex-start;"> <div style="text-align: center;"> <p>New type</p>  <p>(Part No. : 32061715)</p> </div> <div style="text-align: center;"> <p>Old type</p>  <p>(Part No. : 32061707)</p> </div> </div>	<p>When the longitudinal position of the cloth cutting knife is improper :</p> <ul style="list-style-type: none"> ○ For the cut-after knife, the stitches of the top section or narrow section of eyelet will be cut. ○ For the cut-before knife, stitches near the top section of eyelet is deformed.

Standard Adjustment

2) Adjusting the lateral position of the cloth cutting knife

Adjust the knife base ② so that the cut section in terms of the stitches at parallel section is equal on the left and right sides.

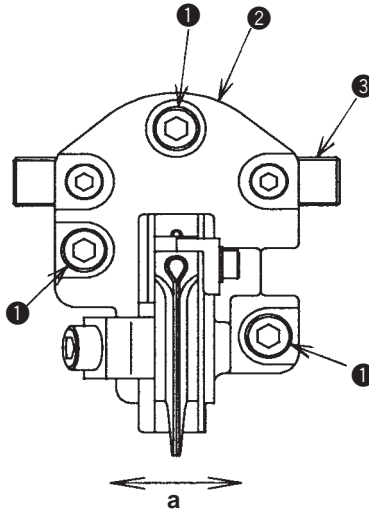

3) Adjusting the inclination of the cloth cutting knife

Adjust the knife base ② so that the cut section in terms of the stitches at parallel section is parallel.

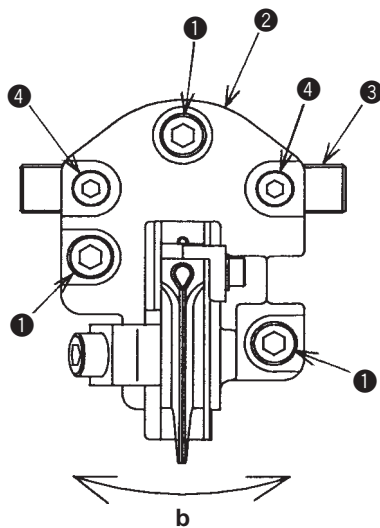

Adjustment Procedures	Results of Improper Adjustment
<p>2) Adjusting the lateral position of the cloth cutting knife</p> <ol style="list-style-type: none"> 1. Loosen three knife base setscrews ❶. 2. Adjust the position by moving knife base ❷ together with knife base key ❸ to the right and left as the arrow mark “a”. 	<p>When the lateral position of the cloth cutting knife is improper :</p> <ul style="list-style-type: none"> ○ For the cut-after knife, stitches of eyelet section or parallel section are cut. ○ For the cut-before knife, stitches of parallel section or eyelet section are deformed.
<p>3) Adjusting the inclination of the cloth cutting knife</p> <ol style="list-style-type: none"> 1. Loosen three knife base setscrews ❶ and two knife base key setscrews ❷. 2. Move knife base ❸ as the arrow mark “b” to adjust the inclination. 	<p>When the cloth cutting knife tilts :</p> <ul style="list-style-type: none"> ○ For the cut-after knife, stitches of eyelet section or parallel section are cut. ○ For the cut-before knife, stitches of parallel section or eyelet section are deformed.

(12) Adjusting the knife holder

Standard Adjustment

1) Adjusting the longitudinal position of the knife holder

Adjust the position of the knife holder ③ so that the plane A of knife holder ③ is aligned with the plane B of cloth cutting knife ⑤.

Old

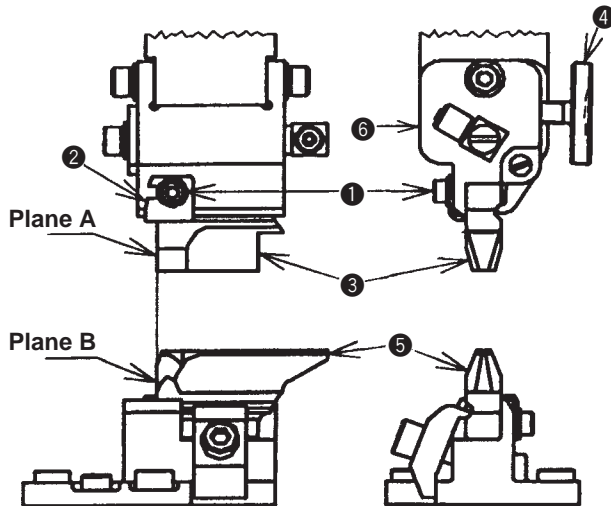

New

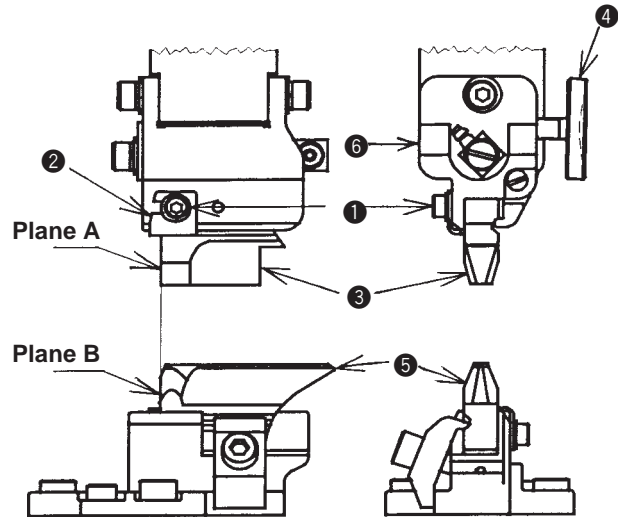

2) Adjusting the lateral position of the knife holder

Adjust knife installing base ④ so that cloth cutting knife ③ in terms of knife holder ② is located in the center.

Old

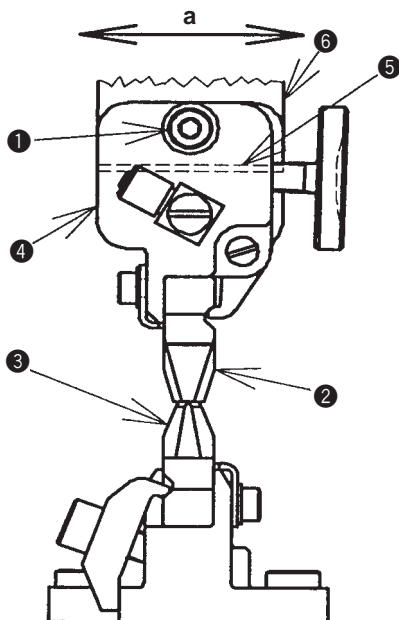

New

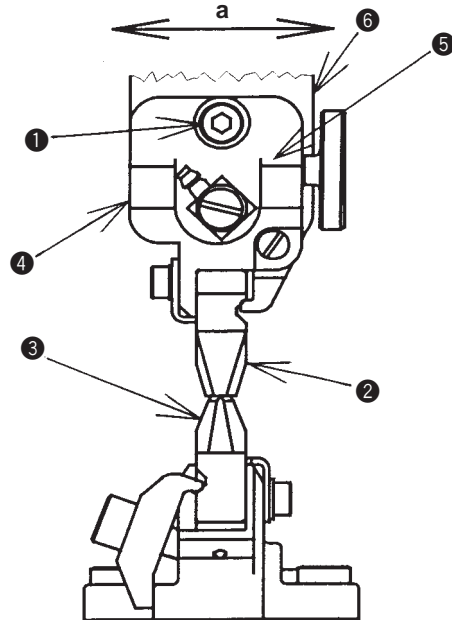

Adjustment Procedures	Results of Improper Adjustment
<p>1) Adjusting the longitudinal position of the knife holder</p> <ol style="list-style-type: none"> Loosen knife stopper setscrew ①. Loosen knife fixing plate setscrew ④ and adjust so that the plane A of knife holder ③ is aligned with the plane B of cloth cutting knife ⑤. Then tighten knife fixing plate setscrew ④ to fix knife holder ③. Press knife stopper ② against knife holder ③. Then tighten knife stopper setscrew ① to fix the stopper. <p>(Caution)</p> <ol style="list-style-type: none"> Note that there are new and old knife installing bases ⑥. For the new type, in case of SS/RS types and JS/CS/TS types, the respective positions of knife stopper are different from each other. For the new type, in case of JS/CS/TS types, two stoppers are added to the air blow hole for SS/RS types. <div data-bbox="220 786 927 1099"> <p>Screw hole for knife stopper (SS, RS)</p> <p>Screw hole for knife stopper (JS, CS, TS)</p> <p>Hole for air blow (JS, CS, TS)</p> <p>Hole for air blow (SS, RS) (With stoppers in case of JS, CS, TS)</p> <p>Screw hole for knife stopper</p> <p>Hole for air blow</p> <p>New (Part No. : 32061210)</p> <p>Old (Part No. : 32061202)</p> </div>	<p>When the longitudinal position of the knife holder is improper :</p> <ul style="list-style-type: none"> ○ Cutting the cloth at a given length cannot be performed. ○ The hole of knife holder comes in contact with the knife, and the cloth on the part cannot be cut. ○ The hole of knife holder comes in contact with the knife, and cloth waste cannot be collected.
<p>2) Adjusting the lateral position of the knife holder</p> <ol style="list-style-type: none"> Turn the cloth cutting dial and lower the knife holder ② to the state immediately before knife holder ② and cloth cutting knife ③ engage with each other. Loosen two setscrews (rear and front) ① in the knife installing base. Adjust knife installing base ④ to the left and right as the arrow mark "a" so that cloth cutting knife ③ comes in the center of knife holder ②. Then tighten two setscrews ① (rear and front) in the knife installing base to fix knife installing base ④. <p>(Caution)</p> <ol style="list-style-type: none"> When fixing knife installing base ④, adjust so that there is no clearance between the respective knife installing base ④, cloth cutting spacer ⑤ and direct drive shaft ⑥. If there is any clearance, knife holder ② tilts and cutting failure or cloth cutting knife ③ breakage may occur. Note that there are new and old knife installing bases ④. 	<p>When the lateral position of the knife holder is improper :</p> <ul style="list-style-type: none"> ○ The hole of knife holder comes in contact with the knife, and the cloth on the part cannot be cut. ○ The hole of knife holder comes in contact with the knife, and cloth waste cannot be collected.

Standard Adjustment

3) Adjusting the inclination of the knife holder and the backlash of the cloth cutting direct drive shaft

Adjust the inclination of the knife holder so that knife holder ③ in terms of the cloth cutting knife is parallel.

Old

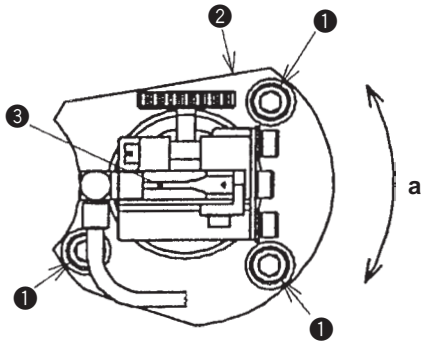

New

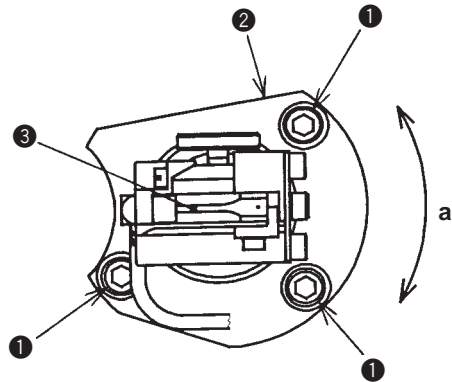

Adjust the backlash of cloth cutting direct drive shaft ④ to 0.2 to 0.3 mm.

Old

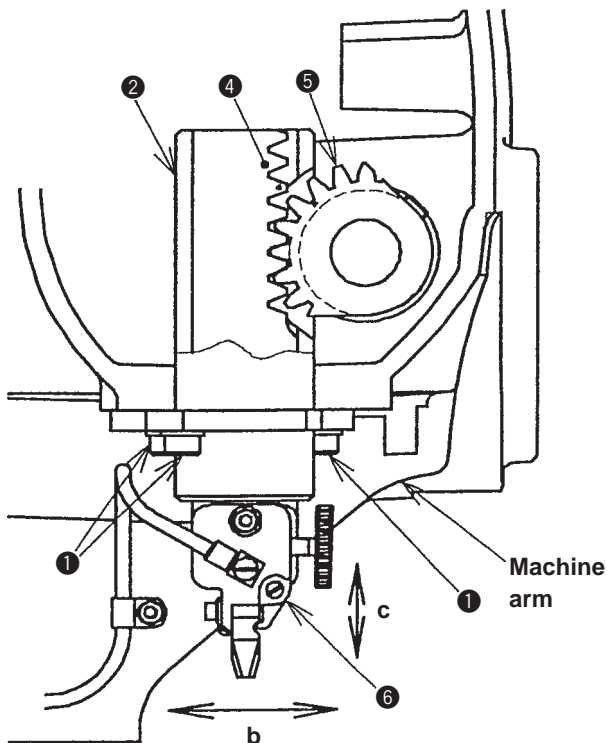

New

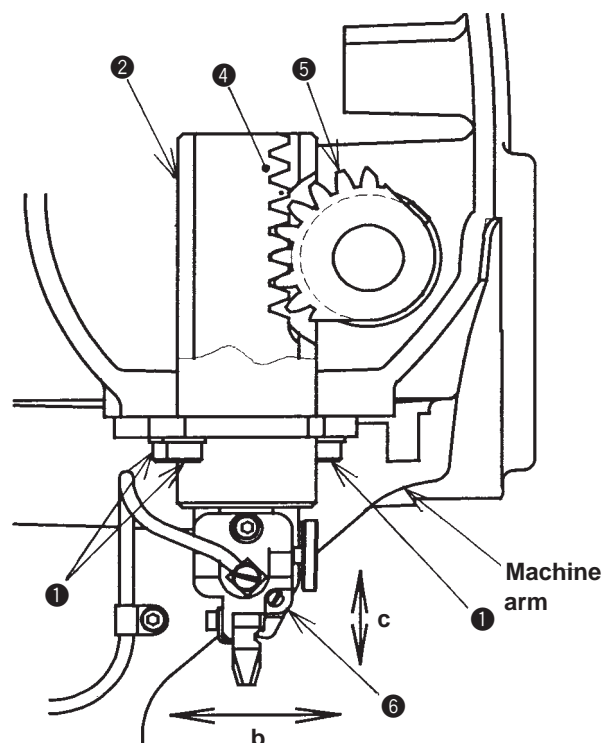

Adjustment Procedures	Results of Improper Adjustment
<p>Adjusting the inclination of the knife holder</p> <ol style="list-style-type: none"> 1. Loosen three setscrews ① in the cloth cutting metal. 2. Move cloth cutting metal ② as the arrow mark “a” and adjust so that knife holder ③ in terms of the cloth cutting knife is parallel. <p>(Caution) When performing adjustment of the inclination of the knife holder, backlash of cloth cutting direct drive gear ⑤ and cloth cutting direct drive shaft ④ changes. Perform the adjustment of the backlash of cloth cutting direct drive gear ⑤ and cloth cutting direct drive shaft ④ as well.</p>	<p>When the knife holder tilts :</p> <ul style="list-style-type: none"> ○ Cutting the cloth at a given length cannot be performed. ○ The hole of knife holder comes in contact with the knife, and the cloth on the part cannot be cut. ○ The hole of knife holder comes in contact with the knife, and cloth waste cannot be collected.
<p>Adjusting the backlash of the cloth cutting direct drive shaft</p> <ol style="list-style-type: none"> 1. Loosen three setscrews ① in the cloth cutting metal. 2. Move cloth cutting metal ② in the direction of the arrow mark “b” and adjust the backlash. (Adjust the play amount of the backlash to 0.2 to 0.3 mm when holding cloth cutting knife installing base ⑥ and moving it in the direction of the arrow mark “c”.) <p>(Caution) 1. When the backlash of the cloth cutting direct drive shaft ④ has been performed, the lateral position of the knife holder may change. Perform the adjustment of “(12) - 2) Adjusting the lateral position of the knife holder” as well.</p> <ol style="list-style-type: none"> 2. Note that there are new and old knife installing bases ⑥. 	<p>When the backlash is excessively small :</p> <ul style="list-style-type: none"> ○ Step-out of the cloth cutting stepping motor occurs. <p>When the backlash is excessively large :</p> <ul style="list-style-type: none"> ○ Cloth cutting failure occurs.

(13) Installing position of the needle thread trimming knife

Standard Adjustment

○ S and R type (long thread trimming)

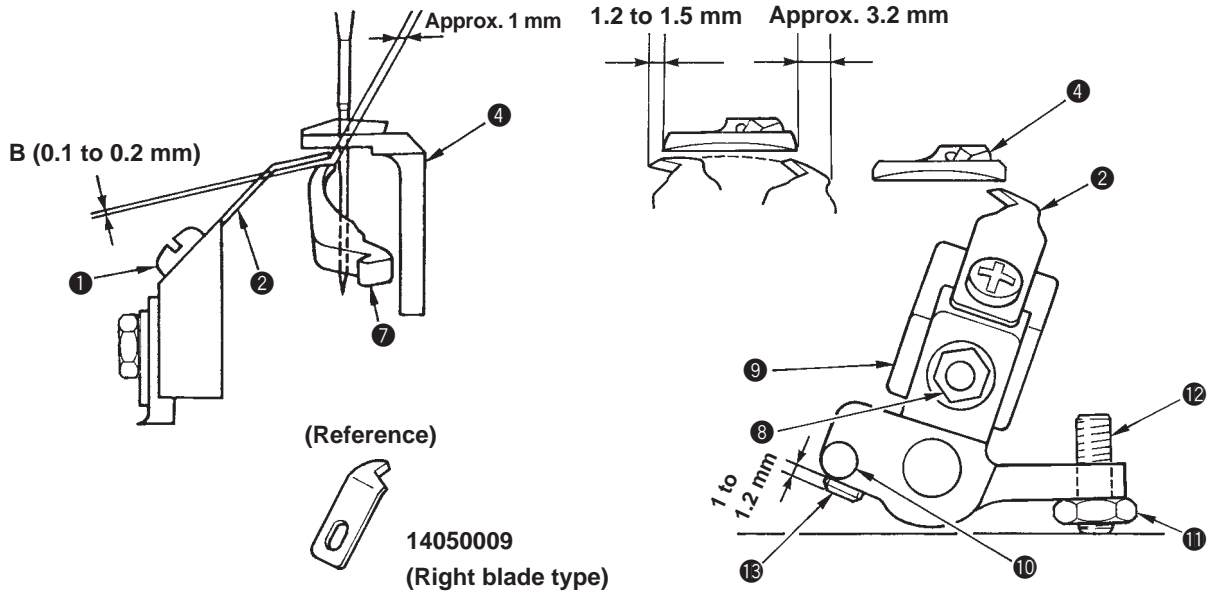

○ T type (short thread trimming without gimp)

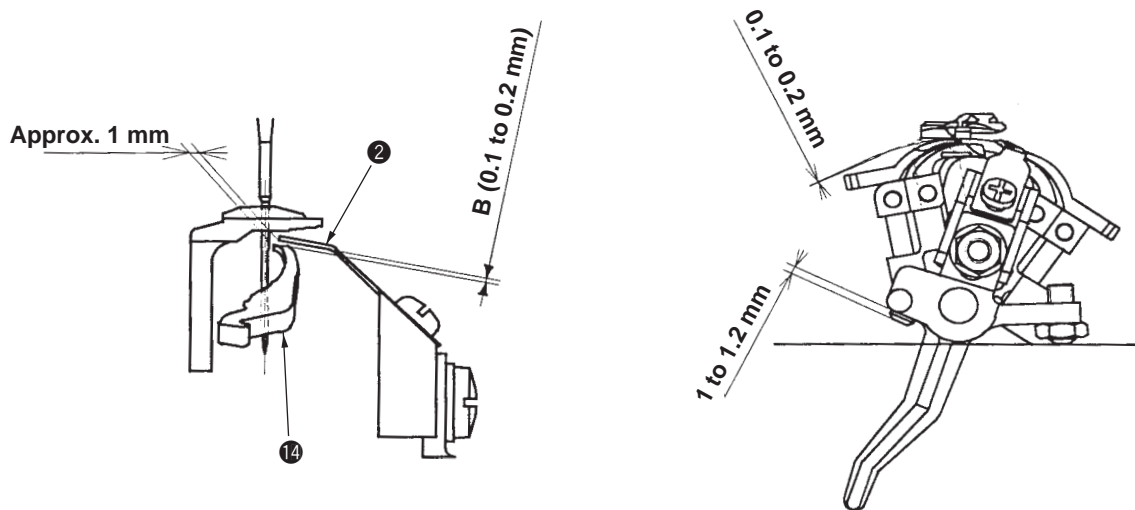

Adjustment Procedures	Results of Improper Adjustment
<p>○ S/R types (long thread trimming)</p> <ol style="list-style-type: none"> The clearance between needle thread trimming knife J ② and the needle is approximately 1 mm. Loosen setscrew ① and move needle thread trimming knife J ② to adjust the clearance. Loosen nut ⑧, move needle thread trimming knife adjusting base ⑨ up and down, and adjust clearance “B” between the needle thread trimming knife J and spreader, right ⑦ to 0.1 to 0.2 mm to obtain the height of needle thread trimming knife J ②. <p>(Caution) When needle thread trimming knife J ② comes in contact with spreader, right ⑦, breakage of components will be caused.</p> <ol style="list-style-type: none"> The initial position of needle thread trimming knife J ② is the position where it protrudes 3.2 mm from throat plate ④. Loosen adjustment nut ⑪ and adjust the initial position with adjustment screw ⑫. Adjust the operating position of needle thread trimming knife J ② within the range where needle thread trimming knife J ② comes out by 1.2 to 1.5 mm from throat plate ④ when needle thread trimming actuating arm ⑩ is moved counterclockwise and stopper B ⑬ of the needle thread trimming knife actuating arm comes in contact with the top surface of the looper bracket. <p>(Caution) 1. Stopper B ⑬ of the needle thread trimming actuating arm is a double thread screw. 2. When the right blade type knife, 14050009 is used, refer to the item ○ Adjusting the right blade type (32023319) of “(13) Installing position of the needle thread trimming knife”.</p> <p>○ T type (short thread trimming without gimp) Perform the adjustment of aforementioned steps 1. through 4. with left looper (eye looper) ⑭.</p> <p>(Caution) When the clearance between the top end of needle thread trimming knife J ② and needle (end of left looper ⑭) is smaller than 1 mm, even looper thread is cut and looper thread holding cannot be performed. When such phenomenon as this occurs, adjust the clearance of 1 mm to rather larger than 1 mm.</p>	

(13) Installing position of the needle thread trimming knife

Standard Adjustment

○ J and C type (short thread trimming)

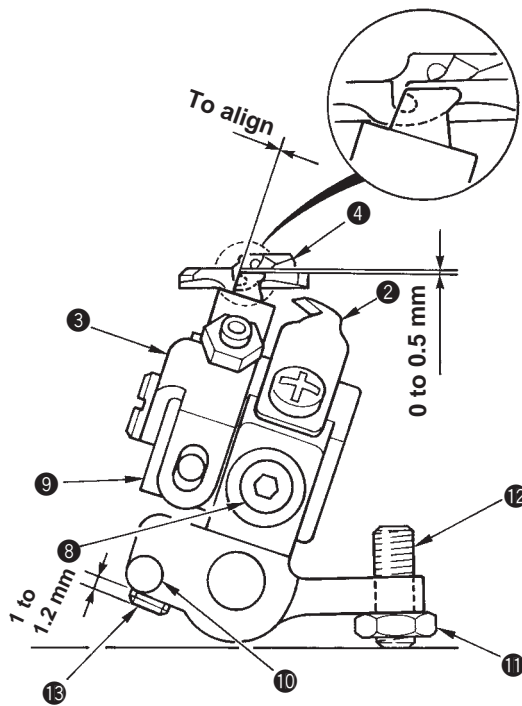
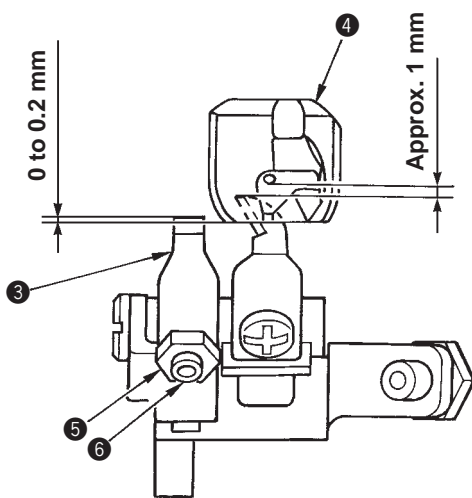
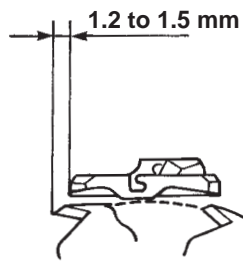
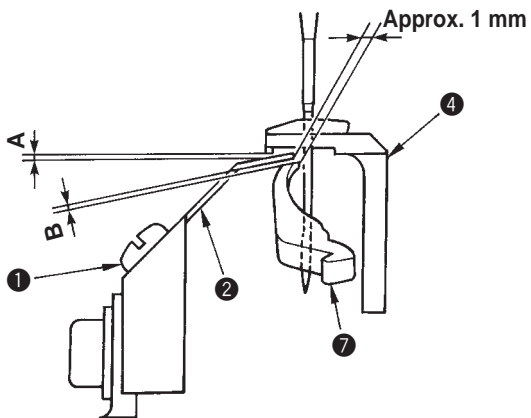

Adjustment Procedures	Results of Improper Adjustment
<p>○ J and C type (short thread trimming)</p> <ol style="list-style-type: none"> 1. The clearance between needle thread trimming knife J ② and the needle is approximately 1 mm. Loosen setscrew ① and move needle thread trimming knife J ② to adjust the clearance. 2. The overlapping amount between looper thread presser ③ and the top end section of throat plate ④ is 0 to 0.2 mm, and adjust so that no clearance is provided between them. Loosen adjustment nut ⑤ and adjust the position of the top end of looper thread presser ③ with adjustment screw ⑥. 3. The height of needle thread trimming knife J ② is determined by the adjustment value of looper thread presser ③. After the adjustment of step 4) below, confirm that clearance A between the looper thread presser and throat plate ④ and that B between the looper thread presser and right spreader ⑦ are securely obtained. 4. The height of looper thread presser ③ is the position where the top end is lowered by 0 to 0.5 mm from the flat face of throat plate ④. Loosen setscrew ⑧ and move needle thread trimming knife adjustment base ⑨ up or down to adjust the height of the top end of looper thread presser ③. <p>(Caution) When needle thread trimming knife J ② comes in contact with throat plate ④ and spreader, right ⑦, breakage of components will be caused. Make sure of the clearances “A” and “B”.</p> <ol style="list-style-type: none"> 5. The initial position of needle thread trimming knife J ② and looper thread presser ③ is the position where the left corner of the top end of looper thread presser ③ is aligned with the right corner of the slot of throat plate ④. Loosen adjustment nut ⑪ and adjust the initial position with adjustment screw ⑫. 6. The operating position of needle thread trimming knife J ② is the position where needle thread trimming knife J ② comes out by 1.2 to 1.5 mm from throat plate ④ when needle thread trimming actuating arm ⑩ is moved counterclockwise and stopper B ⑬ of the needle thread trimming actuating arm comes in contact with the top surface of the looper bracket. When the adjustment is necessary, remove needle thread trimming adjusting base ⑨ once with setscrew ⑧ and adjust the protruding amount of stopper B of the needle thread trimming actuating arm ⑬ to 1 to 1.2 mm. <p>(Caution) Stopper B ⑬ of the needle thread trimming actuating arm is a double thread screw.</p>	

(13) Installing position of the needle thread trimming knife

Standard Adjustment

○ Adjusting the right blade type (32023319)

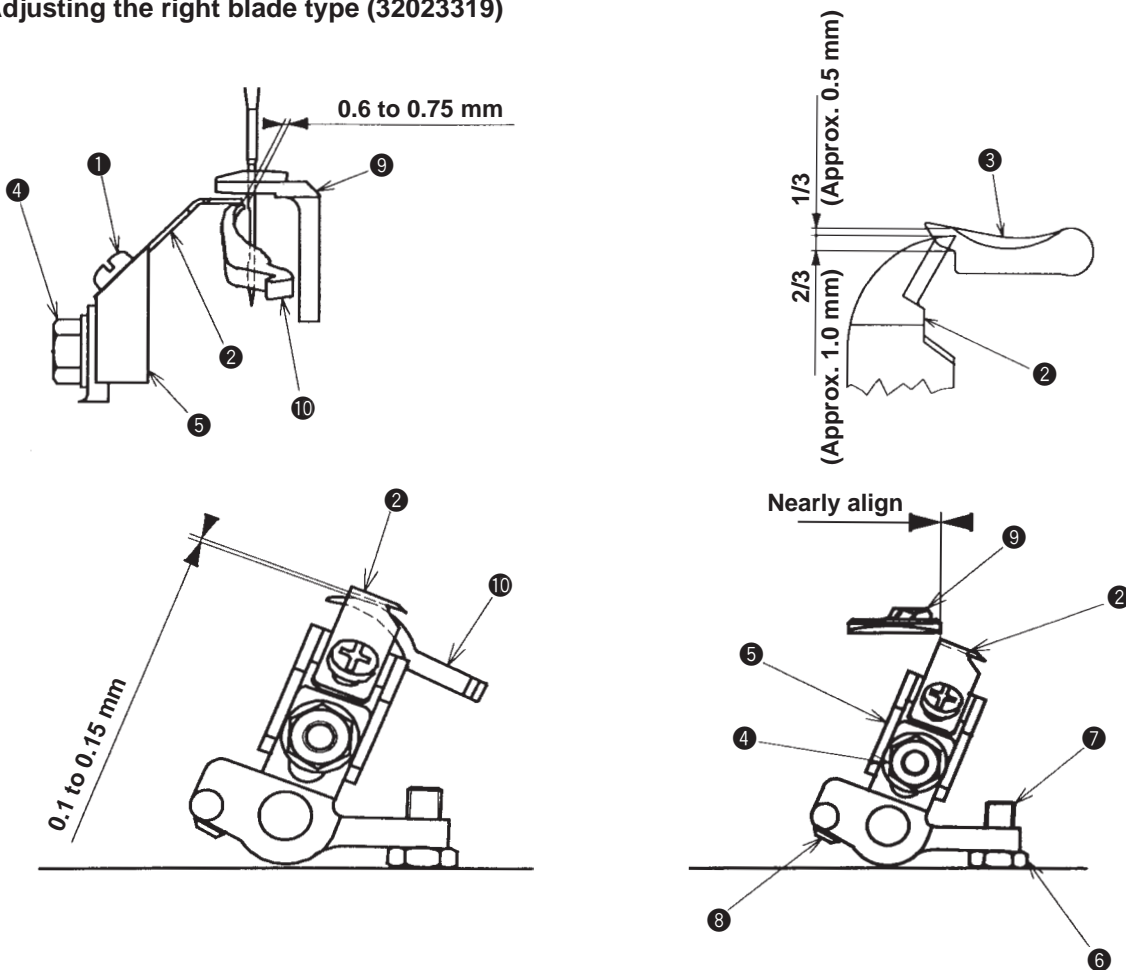

Align with line on corner section

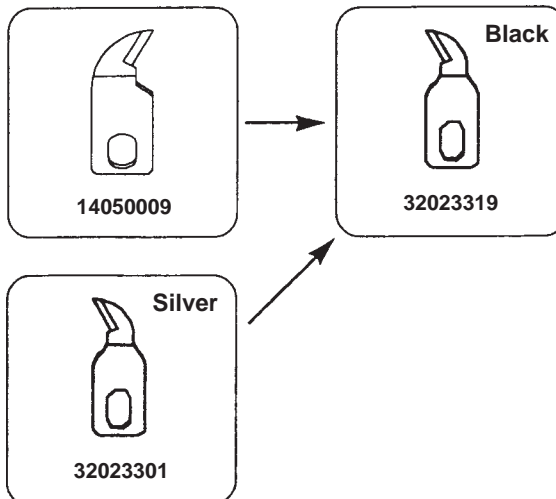
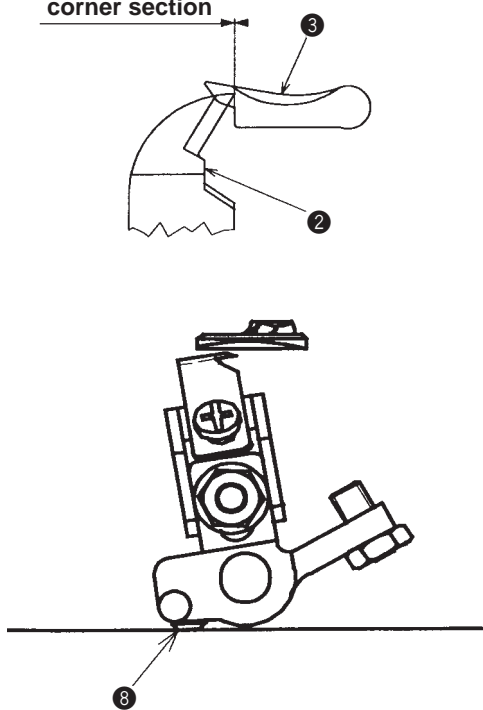

When the needle thread trimming knife is Part No. 14050009, replace it with Part No. 32023319. (It is recommended to replace it with Part No. 32023319 in case of Part No. 32023301 as well in order to stabilize the length of remaining needle thread.)

Adjustment Procedures	Results of Improper Adjustment
<ul style="list-style-type: none"> ○ S type and R type (Long thread trimming) : Right blade type ○ Clearance between the top end of needle thread trimming knife ② and the needle is 0.6 to 0.75 mm. 1. Loosen setscrew ① in the needle thread trimming knife and move needle thread trimming knife ② in the oblique direction to adjust the clearance. For reference of adjustment, adjust the position of the needle thread trimming knife ② to the position where it overlaps by approximately 2/3 as against the width of the top end of right-hand looper ③. 1) Clearance between the bottom face of needle thread trimming knife ② and the top surface of right-hand spreader ⑩ is 0.1 to 0.15 mm. 2. Loosen nut ④ of the needle thread trimming knife adjusting base and adjust needle thread trimming knife adjusting base ⑤ in the vertical direction. 3. Origin position of the needle thread trimming knife For reference, the origin position is the position where the left-hand side of the needle thread trimming knife ② is almost aligned with the right-hand side of the throat plate ⑨. Loosen lock nut ⑥ and adjust the position with needle thread trimming knife actuating plate stopper A ⑦. 4. Maximum operating range of the needle thread trimming knife <ul style="list-style-type: none"> 1) Move right-hand looper ③ to the leftmost position. 2) In the state that the needle thread trimming knife ② is pressed to the leftmost position, adjust so that the top end of of the needle thread trimming knife ② is aligned with the line on the corner of right-hand looper ③ with needle thread trimming knife actuating arm stopper B ⑧. 3) Needle thread trimming knife actuating arm stopper B ⑧ consists of double screws. Remove the upper screw and turn the lower screw to adjust. After completion of the adjustment, attach the upper screw and fix the stopper B. 	

(14) Adjusting the needle thread trimming vertical moving arm

Standard Adjustment

The vertical position of needle thread trimming vertical moving arm 15 is as follows :

- (Initial position)

When the needle threaded trimming is OFF and needle thread trimming vertical moving arm 15 is raised, clearance A of pin 17 of needle thread trimming moving arm 16 is 0.2 mm.

- (Operating position)

When needle thread trimming is ON and needle thread trimming vertical moving arm 15 lowers, move needle thread trimming moving arm 16 by hand and a slight clearance B (0.1 to 0.2 mm) is provided between pin 17 of needle thread trimming moving arm 16 and needle thread trimming vertical moving arm 15 when stopper adjusting screw 3 comes in close contact with looper bracket 4.

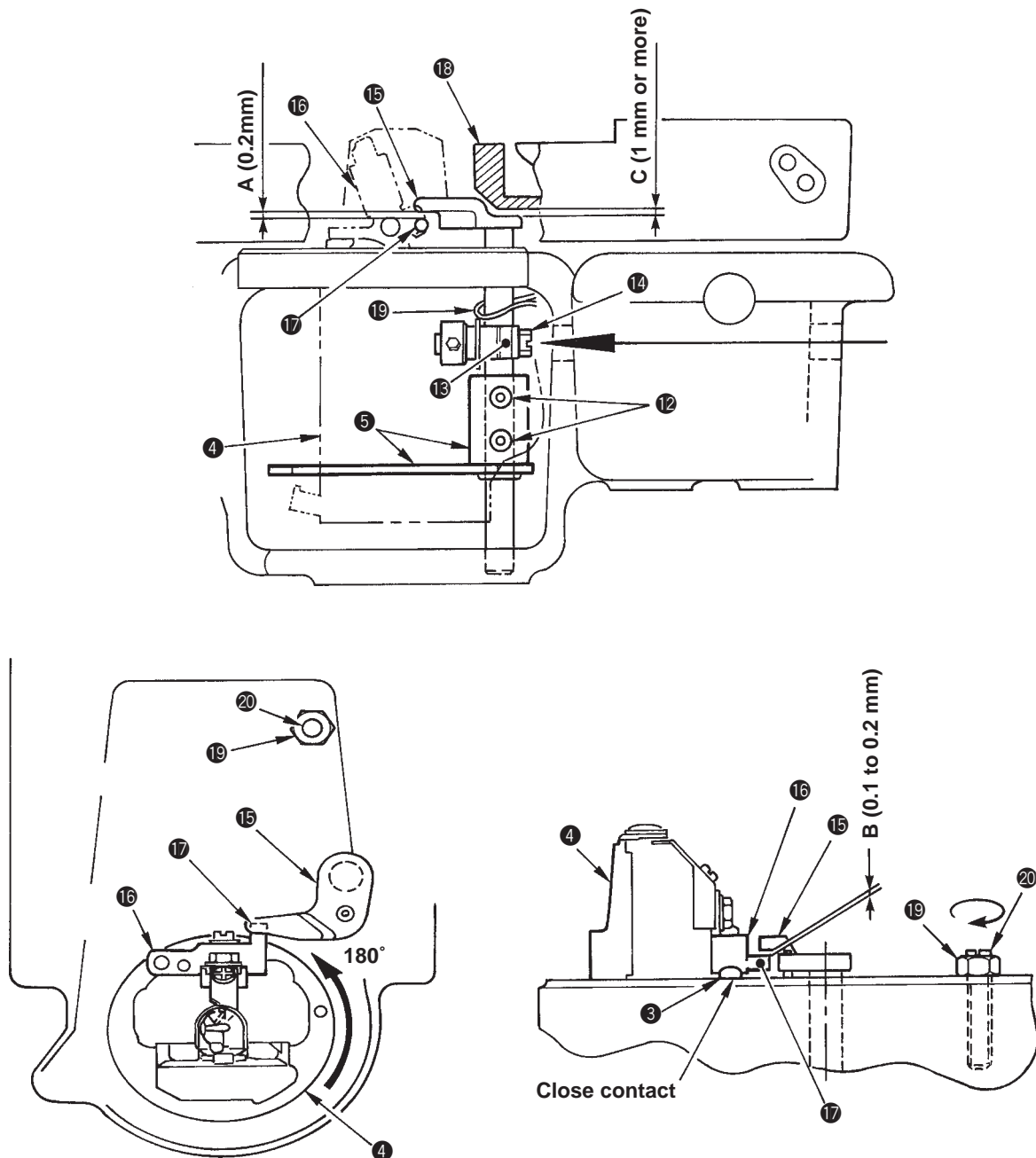

Adjustment Procedures	Results of Improper Adjustment
<p>1) Adjusting the initial position</p> <ol style="list-style-type: none"> 1. Perform the adjustment in the state that the power is turned OFF and the air is being supplied since the adjustment is performed in the state that needle thread trimming cylinder is OFF (extended). Turn looper bracket ④ in the rear (180°). 2. Insert a tool from the hole on the machine bed side and loosen clamp screw ⑭ in vertical moving arm bracket ⑬. Move needle thread trimming vertical moving arm ⑮ up or down and adjust clearance A (0.2 mm) of pin ⑰ of needle thread trimming moving arm ⑯. At this time, make sure that clearance C between the arm and feed base ⑱ is 1 mm or more. After the adjustment, securely tighten clamp screw ⑭. 3. After adjusting the initial position, be sure to adjust the operating position. <p>(Caution) If there is interference in clearance C, defective feed will be caused. If there is no clearance C, check again the adjustment of needle thread trimming knife.</p> <p>* In case of the aforementioned step 3), when the machine is the short thread trimming (J/C) type, needle thread trimming vertical moving arm can be drawn upward. When the machine is the long thread trimming (S/R) type, loosen setscrews ⑫ in looper thread haul arm ⑤ to draw the arm. When returning needle thread trimming vertical moving arm ⑮, apply a small quantity of grease to the shaft section and insert oil wick ⑲ on vertical moving arm bracket ⑬.</p>	<p>When clearance A in the initial position is large :</p> <ul style="list-style-type: none"> ○ Clearance B does not become small by the operating position adjustment and stroke of needle thread trimming knife is insufficient. As a result, thread trimming failure will be caused. ○ Clearance C between the arm and feed base ⑱ interferes and defective feed will be caused. <p>When there is no clearance A in the initial position :</p> <ul style="list-style-type: none"> ○ When looper bracket ④ turns, pin ⑰ of needle thread trimming moving arm ⑯ interferes with needle thread trimming vertical moving arm ⑮. As a result, turning failure will be caused. ○ Similarly, pin ⑰ comes in contact with needle thread trimming moving arm ⑮ when the bracket turns and the needle thread trimming knife moves. As a result, defective sewing or sewing components breakage will be caused.
<p>2) Adjusting the operating position</p> <ol style="list-style-type: none"> 1. Operating position changes when the initial position adjustment is performed. 2. Turn looper bracket ④ in the rear (180°) in the state that the power is turned ON (test mode 2) and the air is being supplied. (State that the needle thread trimming cylinder is ON) 3. Turn ON the needle thread trimming cylinder in the test mode 2. Loosen nut ⑲ and turn adjusting screw ⑳. Then needle thread trimming vertical moving arm ⑮ moves up or down. Move needle thread trimming moving arm ⑯ by hand and adjust clearance B between pin ⑰ of needle thread trimming moving arm ⑯ and needle thread trimming vertical moving arm ⑮ when stopper adjusting screw ③ comes in close contact with looper bracket ④. 4. After the adjustment, securely tighten nut ⑲. 5. After the aforementioned adjustment, perform “(24) Adjusting the looper thread haul amount (long thread trimming/short thread trimming)” and “(25) Adjusting the looper thread haul driving arm (long thread trimming)”. 	<p>When clearance B in the operating position is large :</p> <ul style="list-style-type: none"> ○ The stroke of needle thread trimming knife is insufficient. As a result, thread trimming failure will be caused. <p>When there is no clearance B in the operating position :</p> <ul style="list-style-type: none"> ○ Excessive force is applied to needle thread trimming moving arm ⑯. As a result, component breakage will be caused.

(15) Adjusting the looper thread and gimp trimming

Standard Adjustment

- S and R type (long thread trimming)

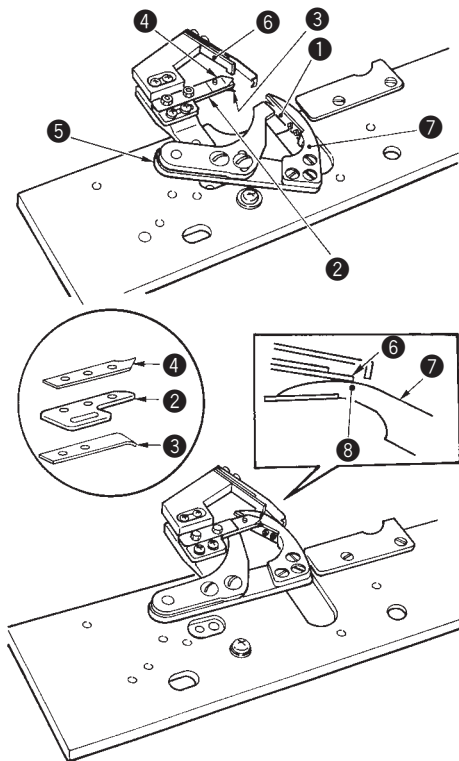

- J and C type (short thread trimming)

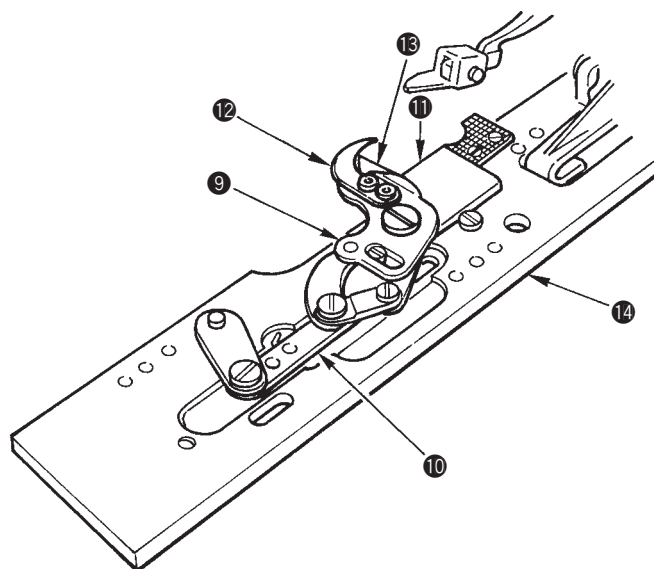

Adjustment Procedures	Results of Improper Adjustment
<p>○ S and R type (long thread trimming)</p> <p>Looper thread and gimp trimming is operated at the position of the feed base origin.</p> <ol style="list-style-type: none"> 1. Adjust so that looper thread and gimp are separated upward and downward by thread handling plate ❶. 2. Precisely hold looper thread between looper thread clamp fixing plate ❷ and looper thread clamp ❸ of the plate spring and gimp between looper thread clamp fixing plate ❷ and gimp clamp ❹ of the plate spring. 3. Adjust so that the top end of counter knife ❻ is aligned with engraved marker dot ❸ of moving knife ❼ when the stroke of looper thread trimming actuating arm ❺ is maximum. <p>(Caution) When the cut end (thread waste) of looper thread or gimp is clamped with looper thread clamp ❸ or gimp clamp ❹, clamp failure occurs. As a result, stitch skipping at the sewing start or defective stitches will occur. So, remove the thread waste.</p>	
<p>○ J and C type (short thread trimming)</p> <p>(Caution) When the feed base is manually moved to the rear until it will go no further, upper knife lower cover ❸ rides on the cloth cutting knife and remove presser unit ❹.</p> <p>Looper thread and gimp trimming is operated at the position of the feed base origin after the presser has been lifted.</p> <ol style="list-style-type: none"> 1. Looper thread and gimp have been adjusted so that they are separated from the cloth by thread handling plate ❷. 2. Driving link ❶ is actuated and lower knife ❶ and upper knife ❹ engage with each other to perform thread trimming. 3. Upper knife lower cover ❸ controls the variation of the remaining looper thread when looper thread comes in contact with the blade of the moving knife. <p>(Caution) At the time of delivery or when the following presser sets are used, use the cloth cutting knife with the same size as that supplied with the machine. If a cloth cutting knife with different size is used, the knife unit breakage or the like will be caused.</p> <p>(Reference) In the state of the standard delivery of J type, the presser of M set is installed and that of S set is installed on C type. The sewing length can be changed as shown below by installing the optional presser set and moving the installing position of the knife unit only.</p> <div style="border: 1px solid black; padding: 5px; margin: 10px auto; width: fit-content;"> <p>S set : 16 to 24 (26) mm M set : 24 to 32 (34) mm L set : 32 to 40 (42) mm</p> </div> <p>Numerals in () parentheses are in case of taper bar and without bartack.</p>	

(16) Adjusting the short thread trimming without gimp (T type)

Standard Adjustment

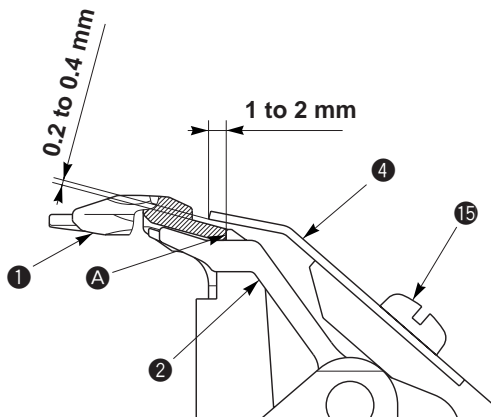
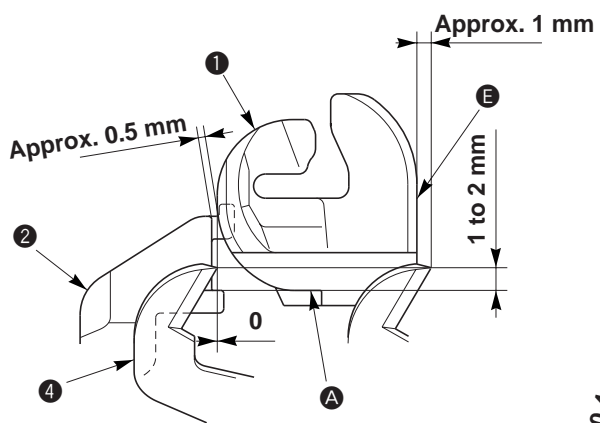
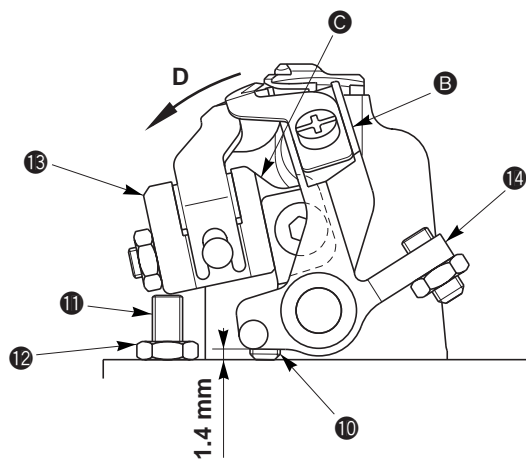
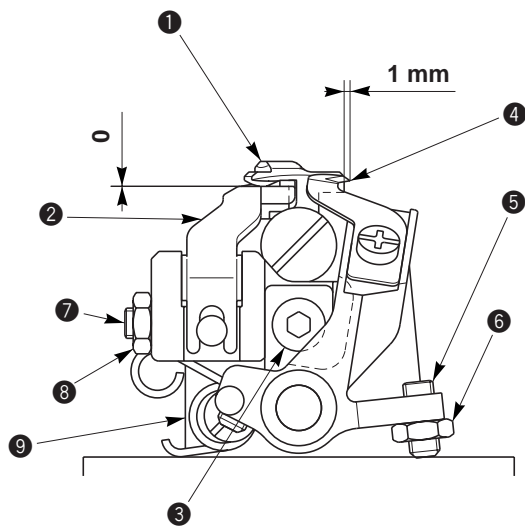

Adjustment Procedures	Results of Improper Adjustment
<p>1. Adjusting the looper thread presser</p> <ol style="list-style-type: none"> 1) Loosen setscrew ③. 2) Fully press downward throat plate ① and install it. 3) Lightly press upward the looper thread presser so that a clearance is not provided between looper thread presser ② and the bottom surface of throat plate ①. Then tighten setscrew ③. 4) Loosen nut ⑧ and tighten adjusting screw ⑦ until the top end of the screw comes in contact with looper bracket ⑨. 5) Further, turn it by 1/4 turn and fix it with nut ⑧. 6) Loosen nut ⑫. 7) Press section ① of installing base ⑬ in the direction of arrow mark D with finger, tighten adjusting screw ⑪ so that the thread guide section of looper thread presser ② protrudes from throat plate ① by approximately 0.5 mm and fix the screw with nut ⑫. <p>2. Adjusting the looper thread trimming knife</p> <ol style="list-style-type: none"> 1) Loosen setscrew ⑮ and adjust so that the top end of looper thread trimming knife ④ is located at the position of 1 to 2 mm from section ① of throat plate ① and that a clearance of 0.2 to 0.4 mm is provided between the bottom surface of the looper thread trimming knife and throat plate ①. 2) Loosen nut ⑥. 3) Tighten adjusting screw ⑤ so that the blade point of looper thread trimming knife ④ protrudes from end plane ② of throat plate ① by approximately 1 mm. Then fix it with nut ⑥. 4) Press section ③ of knife installing base ⑭ in the direction of arrow mark D with finger, tighten adjusting screw ⑩ (double thread screw) so that the top end of looper thread trimming knife ④ aligns with the end plane of throat plate ①. Then fix the base. The standard of the protruding amount of adjusting screw ⑩ is 1.4 mm. <p>(Reference) When the looper thread is not retained immediately after threading or the like, perform sewing after retaining the looper thread at section ① of throat plate ① with looper thread presser ②.</p>	<ul style="list-style-type: none"> ○ When the clearance provided between throat plate ① and the looper thread presser is smaller than the specified value, the looper thread holding force is insufficient. As a result, stitch skipping at the start of sewing or defective roll-in of thread will be caused. ○ When the looper thread presser is excessively pressed to throat plate ①, component breakage or excessive tightness of stitches at the start of sewing will result. ○ When the lateral position of looper thread trimming knife ④ is not obtained, thread trimming failure or interference with the presser will result. ○ When looper thread trimming knife ④ is positioned too high, looper thread trimming failure or cut-off of stitches will result.

(17) Adjusting the position of the looper thread guide plate and the inclination of the counter knife (S/R types)

Standard Adjustment

(Position of the looper thread guide plate)

When turning moving knife ③ in the direction of the arrow mark A, the slot end corner on the lower side of moving knife ③ is aligned with the corner section on the lower side of looper thread guide plate ①. In addition, the top end section of looper thread guide plate ① smoothly slides the periphery of moving knife ③.

(Inclination of the counter knife)

Turn moving knife ③ in the direction of the arrow mark A, and adjust the counter knife so that there is no clearance in the engagement section and they come in uniform contact with each other before or after the corner of the blade of moving knife ③ is aligned with the top end of counter knife ④ (thread trimming).

(Moving knife pin)

Make moving knife pin ⑤ protrude 1.8 to 2 mm in the direction of the rear face of moving knife ③. Remove from looper thread clamp ⑦ the looper thread of sewing start which has fled to the lower side of moving knife ③ and make the thread free from being cut by moving knife ③.

(Caution) Be careful not to touch your hands or the like to the protruding moving knife pin ⑤ during operation.

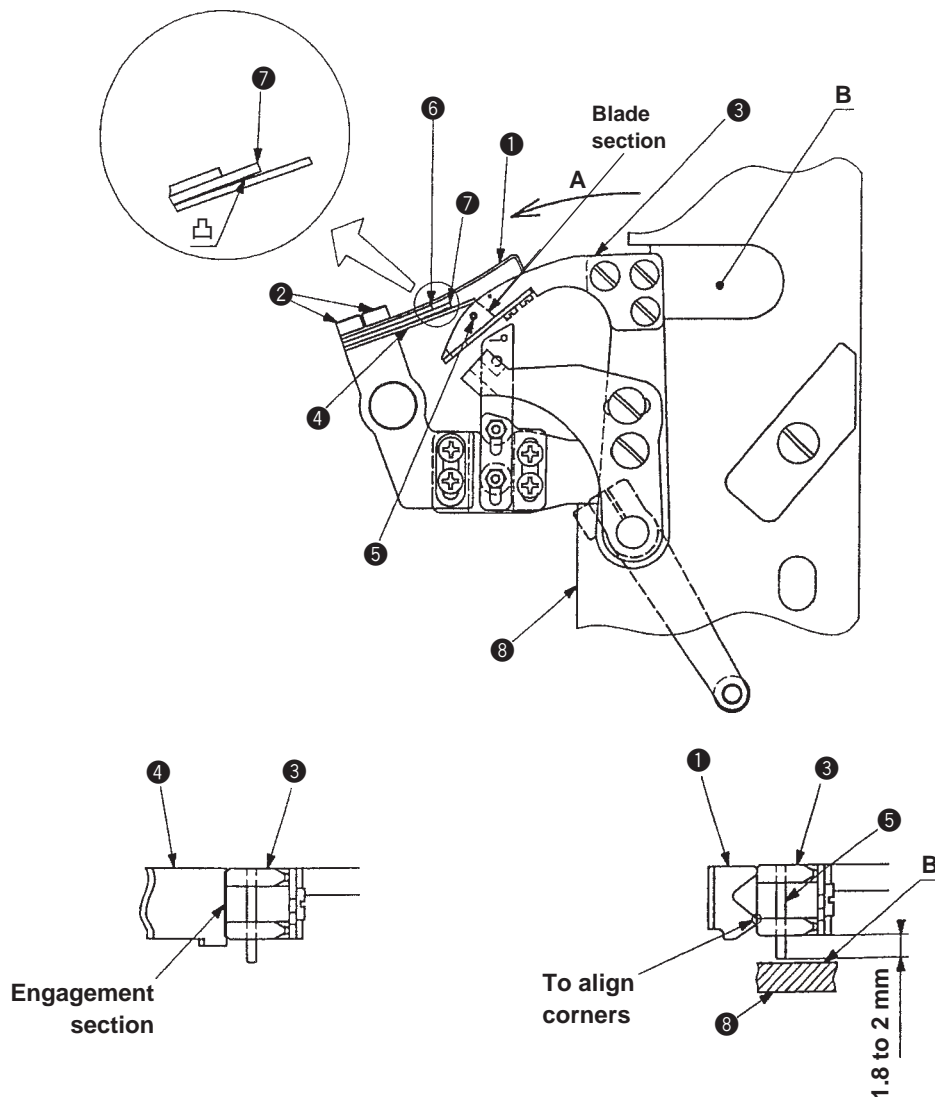

Adjustment Procedures	Results of Improper Adjustment
<p>Remove the knife cover and adjust following the procedure below. (Position of the looper thread guide plate and inclination of the counter knife)</p> <ol style="list-style-type: none"> 1. Loosen two setscrews ②. 2. Turn moving knife ③ in the direction of the arrow mark A and adjust the position of looper thread guide plate ① so that the slot end corner on the lower side of moving knife ③ is aligned with the corner on the lower side of looper thread guide plate ①. 3. Turn moving knife ③ in the direction of the arrow mark A and adjust the position of counter knife ④ so that there is no clearance in the engagement section and they come in uniform contact with each other before or after the corner of the blade of moving knife ③ is aligned with the top end of counter knife ④. 4. Arrange counter knife auxiliary spring, upper ⑥ and counter knife auxiliary spring, lower ⑦ with counter knife ④. (The convex side of counter knife auxiliary spring, lower ⑦ is on the side of counter knife ④.) 5. Tighten two setscrews ② to fix the counter knife. <p>(Caution) When removing or loosening the setscrew of moving knife ③, the position of moving knife ③ may change. In this case, perform the adjustment of the clearance of the looper thread guide plate as described in the aforementioned steps.</p> <p>(Moving knife pin)</p> <ol style="list-style-type: none"> 1. Be sure to confirm that moving knife pin ⑤ protrudes 1.8 to 2 mm in the direction of the rear face of moving knife ③. 	<ul style="list-style-type: none"> ○ If counter knife ④ comes in one-sided contact with the moving knife, thread trimming failure such as end thread remaining, thread cutting failure, etc. will occur. As a result, one-sided worn-out of the blade or blade breakage will be caused. <p>(Caution) If there is a clearance in the center of the engagement section, it is necessary to sharpen the blade.</p> <ul style="list-style-type: none"> ○ If looper thread guide plate ① is located excessively upward, the top end rubs against the slot of moving knife ③. As a result, damage of parts will be caused. In addition, it comes in contact with the knife cover. As a result, malfunction will occur. ○ If looper thread guide plate ① is located excessively downward, looper thread of sewing start cannot be made free and the thread is cut. As a result, thread waste is increased. ○ If the protruding amount of moving knife pin ⑤ is large, the pin interferes with section B of presser plate, right ⑧. As a result, malfunction or parts breakage will be caused. ○ If the protruding amount of moving knife pin ⑤ is small, looper thread of sewing start is cut and thread waste is increased. (In the case where the sewing length is long, moving knife pin ⑤ cannot make free the looper thread of sewing start.)

(18) Adjusting the looper thread clamp and the thread hauling (S/R types)

Standard Adjustment

(Looper thread clamp)

When moving knife ③ is turned in the direction of the arrow mark A, make clearance C between the top end of looper thread clamp fixing plate ⑥ and looper thread hauling plate ⑧ as small as possible (approximately 1 mm), and securely insert looper thread and gimp into the respective clamps.

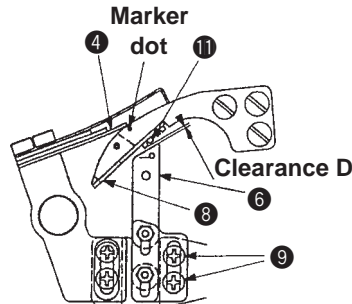

(Looper thread clamp opener)

Turn moving knife ③ in the direction of the arrow mark A and adjust so that looper clamp ⑦ closes and retains looper thread simultaneously when the corner of the blade of moving knife ③ is aligned with the top end of counter knife ④ (thread trimming).

(The bottom face of looper thread clamp opener ⑦ comes off thread clamp pin ⑫).

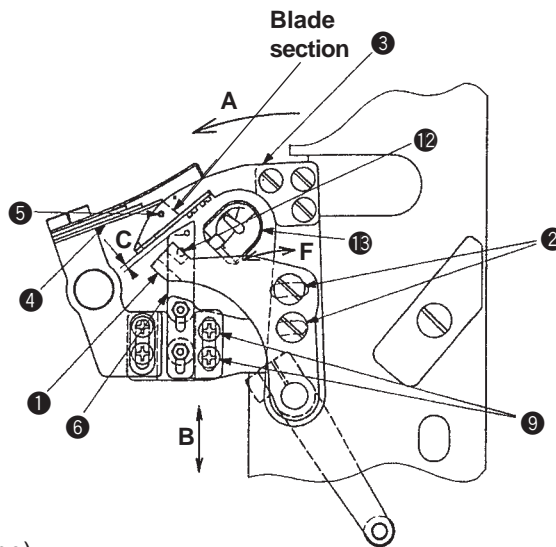

(Looper thread hauling)

When moving knife ③ is turned in the direction of the arrow mark A, adjust so that the top end of looper thread clamp fixing plate ⑥ is aligned with the projection in the center of looper thread hauling plate ⑧ in the vertical direction. By this adjustment, looper thread and gimp separated upward and downward by throat plate ① are hauled by looper thread hauling plate ⑧, and securely inserted and retained between respective clamp plates ⑦ and ⑩ and looper thread clamp fixing plate ⑥.

(Caution) Be careful not to touch your hands or the like to moving knife pin ⑤ protruding in the rear of moving knife ③ during operation.

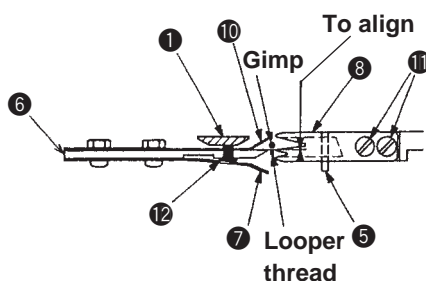

Adjustment Procedures	Results of Improper Adjustment
<p>Remove the knife cover and perform adjustment following the procedure described below.</p> <p>(Looper thread clamp)</p> <ol style="list-style-type: none"> 1. Loosen two setscrews ⑨. 2. Turn moving knife ③ in the direction of the arrow mark A, move looper thread clamp fixing plate ⑥ in the direction of the arrow mark B and make clearance C between the top end of looper thread clamp fixing plate ⑥ and looper thread hauling plate ⑧ as small as possible (approximately 1 mm). As the standard, the clearance is 1 mm. 3. After the adjustment, make sure of the clearances described below. <ol style="list-style-type: none"> 1) When the marker dot engraved on moving knife ③ is aligned with the top end of counter knife ④, the top end of looper thread clamp fixing plate ⑥ does not interfere with setscrews ⑪ in the looper thread hauling plate. (Clearance D) 2) When looper thread clamp opener ① rotates in the direction of the arrow mark A and passes over looper thread clamp ⑩, the top end of the lower face of looper thread clamp opener ① does not interfere with the bending section of looper thread clamp ⑩. <p>(Caution) When the setscrews of moving knife ③ are removed or loosened, the position of moving knife ③ may change. In this case, perform the aforementioned adjustment of the looper thread hauling.</p> <p>(Looper thread clamp opener)</p> <ol style="list-style-type: none"> 1. Loosen two setscrews ②. 2. Turn moving knife ③ in the direction of the arrow mark A, align the corner of the blade section of moving knife ③ with the top end of counter knife ④. 3. Move looper thread clamp opener ① in the direction F and adjust the position so that the bottom face (slant face) comes off thread clamp pin ⑫ and looper thread clamp ⑦ comes in close contact with looper thread clamp fixing plate ⑥. Then tighten two setscrews ② to fix the opener. <p>(Looper thread hauling)</p> <ol style="list-style-type: none"> 1. Loosen two setscrews ⑪. 2. Turn moving knife ③ in the direction of the arrow mark A, align the top end of looper thread clamp fixing plate ⑥ with the projection in the center of looper thread hauling plate ⑧ in the vertical direction. Then tighten two setscrews ⑪. 3. Make sure under the test mode that looper thread is inserted into looper thread clamp ⑦ and gimp into gimp clamp ⑩ referring to "8.- (8) Thread trimming check". <ol style="list-style-type: none"> 1) When both threads are inserted on the side of looper thread clamp ⑦, perform fine adjustment so that the projection in the center of looper thread hauling plate ⑧ is slightly raised upward. 2) When both threads are inserted on the side of gimp clamp ⑩, perform fine adjustment so that the projection in the center of looper thread hauling plate ⑧ is slightly lowered downward. 	<ul style="list-style-type: none"> ○ If clearance C between the top end of looper thread clamp fixing plate ⑥ and looper thread hauling plate ⑧ is excessively large, inserting amount of looper thread and gimp is small. As a result, retaining is not enough and stitch skipping at the sewing start or bird's nest will be caused. ○ If clearance C between the top end of looper thread clamp fixing plate ⑥ and looper thread hauling plate ⑧ is excessively small, the top end of the lower face of looper thread clamp opener ① interferes with the bending section of looper thread clamp ⑩. As a result, parts breakage will be caused. ○ If clearance C between the top end of looper thread clamp fixing plate ⑥ and looper thread hauling plate is excessively small, the top end of looper thread clamp fixing plate ⑥ interferes with setscrews ⑪ in the looper thread hauling plate. As a result, parts breakage will be caused. ○ If the protruding amount of moving knife pin ⑤ is excessively large, the pin interferes with the presser plate, right. As a result, malfunction or parts breakage will be caused. ○ If the height of looper thread clamp fixing plate ⑥ is excessively low, both threads are inserted on the side of looper thread clamp ⑦ and gimp does not come off at the sewing start. As a result, thread trimming failure or thread clamp failure will occur. ○ If the height of looper thread clamp fixing plate ⑥ is excessively high, both threads are inserted on the side of gimp clamp ⑩ and looper thread comes off before starting sewing. As a result, sewing failure will occur.

(19) Adjusting the blade pressure of the looper thread trimming knife (S/R types)

Standard Adjustment

Turn moving knife ③ in the direction of the arrow mark A, and align the top end of counter knife ④ with the periphery of moving knife when the distance from the corner of the blade section of moving knife ③ to counter knife ④ is 2 to 3 mm.

For the reference, the distance from the blade section of moving knife ③ to the counter knife is approximately 3 mm when moving knife pin ⑤ is aligned with the top end of counter knife.

(Caution) Moving knife pin ⑤ protrudes in the direction of the rear face. Be careful not to touch your hands or the like to the pin during operation.

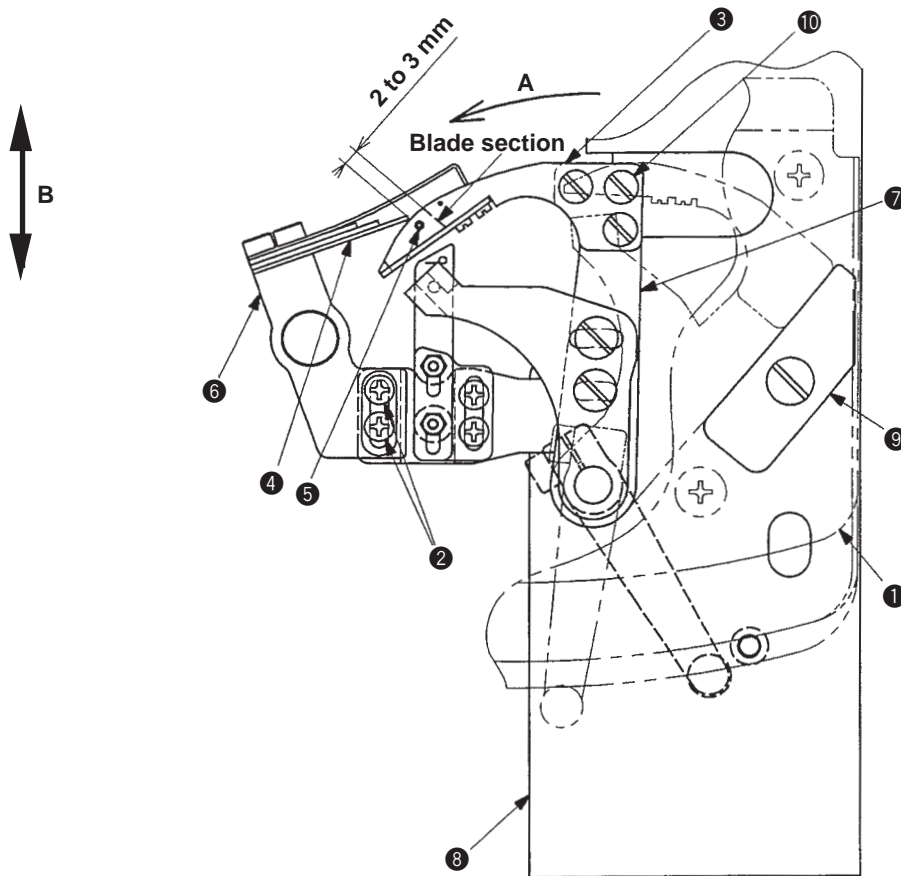

Adjustment Procedures	Results of Improper Adjustment
<p>Remove knife cover ❶ and perform adjustment following the procedure mentioned below.</p> <ol style="list-style-type: none"> 1. Loosen two setscrews ❷. 2. Move counter knife installing base ❸ in the direction B and turn moving knife ❹ in the direction of the arrow mark A to adjust so that the clearance provided between the corner of the blade section and the top end of counter knife ❺ is 2 to 3 mm. <p>(Caution)</p> <ol style="list-style-type: none"> 1. When setscrews ❿ are removed or loosened, the position of moving knife ❸ may change. Perform again the adjustment. 2. If counter knife ❺ comes in one-side contact with the moving knife, either looper thread or gimp cannot be trimmed even when the blade pressure is increased. When performing the aforementioned adjustment, perform the confirmation of “(18) Adjusting the position of the looper thread guide plate and the inclination of the counter knife (S/R types)”. 3. When attaching knife cover ❶, pay attention to the position of rubber stopper ❾. Adjust so that the stopper is placed between the edge of moving knife arm ❷ which has returned to the initial position and the inside edge of knife cover ❶ as shown in the figure. 	<ul style="list-style-type: none"> ○ If the blade pressure is excessively high, the service life of the blade of both knives is deteriorated. In addition, one-sided worn-out or breakage of the blade is apt to occur. ○ If the blade pressure is excessively low, the blade contact is unstable and cut-off of thread (particularly gimp) occurs.

(20) Adjusting the short thread trimming

Standard Adjustment

1) Initial position of the lower knife

The blade section of lower knife ① aligns with the edge of holding plate, right ③.

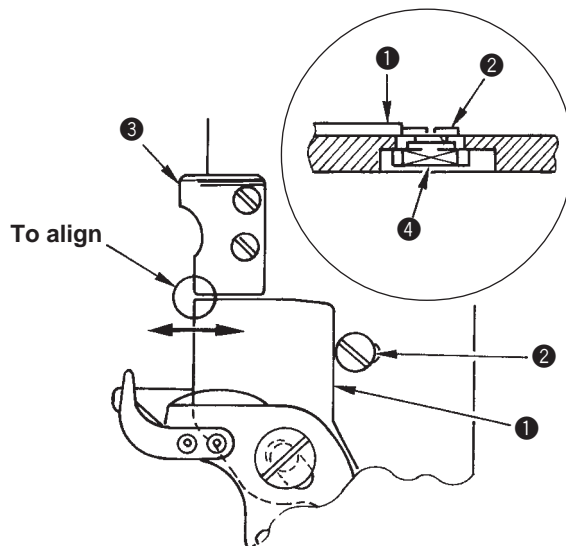

2) Adjusting the stroke of the upper knife

Length of the engagement of upper knife ⑤ and the top end of lower knife ① is 1 to 2 mm.

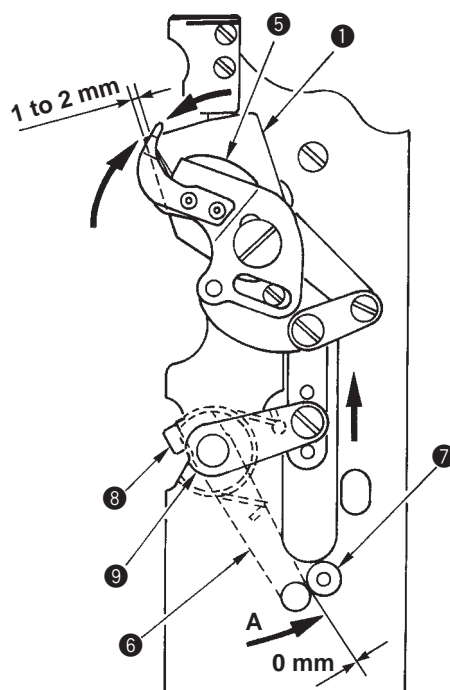

Adjustment Procedures	Results of Improper Adjustment
<p>1) Initial position of the lower knife</p> <ol style="list-style-type: none"> 1. When stopper screw B ② is slightly loosened, it can be slid to the left or right since there is nut ④ in the slot on the rear of the presser plate and stopper screw B ② is screwed in the nut. 2. Loosen stopper screw B ② and move stopper screw B ② to the left or right so that the knife comes in contact with stopper screw B ② when the blade section of lower knife ① aligns with the edge of holding plate, right ③. Then tighten the screw. 	<ul style="list-style-type: none"> ○ If the lower knife comes out from holding plate, right, the throat plate interferes with the lower knife during sewing and the blade section of the knife is damaged. As a result, thread trimming failure or defective feed will occur. In addition, the presser pressure is excessively applied to the lower knife when the presser comes down. As a result, knife breakage will occur. ○ If the lower knife is put back from the holding plate, right, the pressing range of the material with the presser foot is decreased. As a result, defective pressing will occur.
<p>2) Adjusting the stroke of the upper knife</p> <ol style="list-style-type: none"> 1. At this time, loosen clamping screw ⑧ in looper thread trimming driving arm ⑥ and adjust so that looper thread trimming driving arm ⑥ comes in contact with stopper screw ⑦. 2. Move looper thread trimming driving arm ⑥ on the rear of the presser plate in the direction of arrow mark A so that the length of engagement at the top end of the knife is 1 to 2 mm. <p>(Caution) When tightening clamping screw ⑧, perform the work while slightly pressing driving link ⑨ so that the vertical (thrust) play does not occur at looper thread trimming driving arm ⑥.</p>	<ul style="list-style-type: none"> ○ If the length of engagement is excessive, knife return failure will occur. In addition, when setting the presser plate, the roller of lower thread trimming arm cannot be entered in the click section of the lower thread trimming cylinder. ○ If the length of engagement is insufficient, thread trimming failure will occur.

Standard Adjustment

3) Adjusting the knife pressure

Thread is securely trimmed, and upper knife ⑤ and lower knife ① smoothly work. Especially at the time of return, the knives easily return to the initial position by the action of the spring. Knife pressure can be adjusted with fulcrum screw ⑩. The standard is to slightly tighten fulcrum screw ⑩ and return it by half to one rotation.

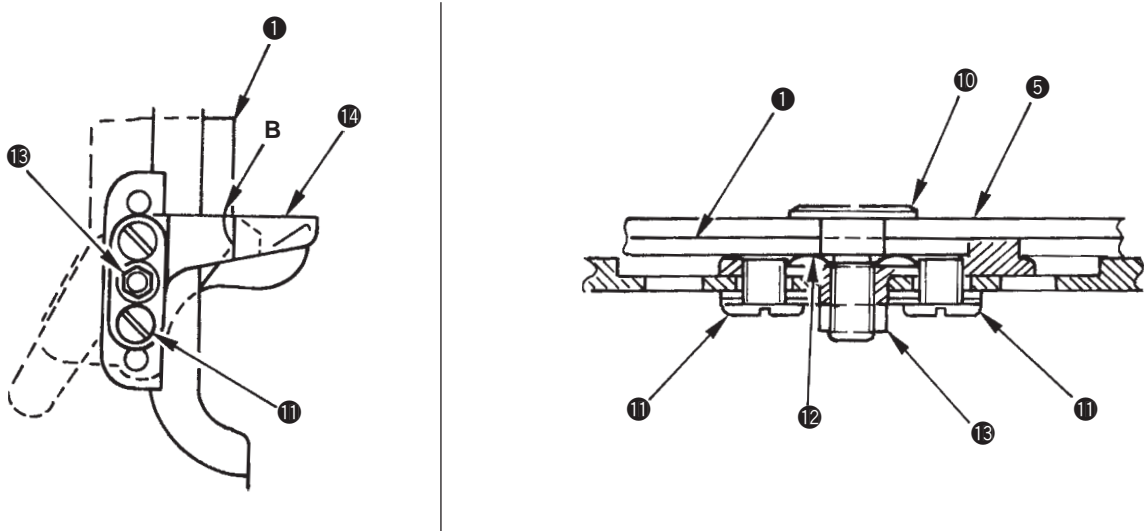

4) Adjusting the position of the thread haul plate

Adjust the position of thread haul plate ⑰ so that the plate does not interfere with the presser foot, left and holding plate, left ⑱ at the waiting position, and it does not interfere with holding plate, left ⑱ when upper knife ⑤ turns (clearance C is open).

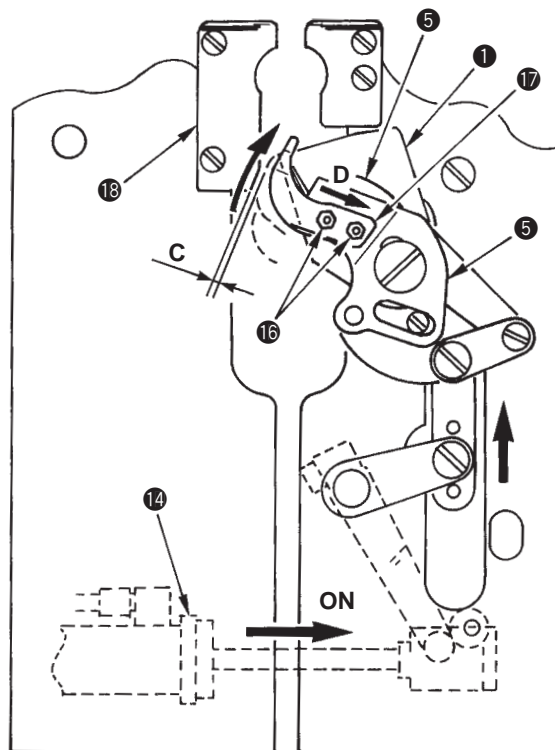

Adjustment Procedures	Results of Improper Adjustment
<p>3) Adjusting the knife pressure</p> <ol style="list-style-type: none"> 1. Loosen nut 13 on the bottom face of the presser plate. 2. Slightly tighten fulcrum screw 10 to the full and return it by one to half rotation. Press fulcrum screw 10 so that it cannot be turned and fix it with nut 13 in the rear. Check the knife pressure by test trimming of rather thick thread by hand. Especially check the pressure by test trimming at the top end and the root of the blade section. 4. If the knife is dull, decrease the amount of return of fulcrum screw 10. At this time, tighten fulcrum screw 10 within the range where the return motion of upper knife 5 and lower knife 1 does not become bad. Then fix it with nut 13. <p>(Caution) 1. In case thread trimming failure occurs even when fulcrum screw 10 is tightened until the return motion of upper knife 5 and lower knife 1 becomes bad, replace the knife or sharpen the blade section.</p> <ol style="list-style-type: none"> 2. When setscrew 11 is removed and the knife is removed together with the knife unit in case of replacement of the presser set or the like, the knife pressure does not change. It is not necessary to adjust the pressure. 3. Apply a small quantity of grease to section B of lower knife 1 where comes in contact with upper knife lower cover 14 for a long period of time. 	<p>When the fulcrum screw is excessively tightened :</p> <ul style="list-style-type: none"> ○ Return of the knife becomes bad and needle may interfere with the knife. ○ Similarly, error is detected due to the defective return of the looper thread trimming cylinder and the sewing machine may stop. ○ Breakage/worn-out of the blade may be caused since the knife pressure is excessively high and the service life of the blade will be deteriorated. <p>When the fulcrum screw is insufficiently tightened :</p> <ul style="list-style-type: none"> ○ A proper knife pressure cannot be obtained and thread trimming failure will occur.
<p>4) Adjusting the position of the thread haul plate</p> <ol style="list-style-type: none"> 1. Loosen two setscrews 16 and move thread haul plate 17 to adjust the position. <ol style="list-style-type: none"> 1) Normally, move thread haul plate 17 in the direction of arrow mark D to adjust the position to such an extent that it hides the blade top of upper knife 5. Then secure an enough clearance C. 2) When the sewing length is short and the looper thread on the side of sewing start runs away from the knife at the time of thread trimming, adjust the position slightly to the reverse direction from D. 2. For the final confirmation, expel the air and operate the plate by hand, or actually turn ON looper thread trimming cylinder 14 with the test mode 2 or the like, and check that there is no interference. When trimming the looper thread, presser goes up and cloth open mechanism is open. <p>(Caution) When adjusting the position where the cloth open mechanism is open, be sure to check the position of thread haul plate 17. Position A where the cloth open mechanism is open requires 1.0 mm or more. If it is less than 1.0 mm, clearance C may not be secured. (Refer to “(9) Adjusting the cloth open”.)</p>	<p>When the thread haul plate excessively comes out in the reverse direction from the arrow mark direction of D :</p> <ul style="list-style-type: none"> ○ The presser steps on the plate when the presser comes down and deformation may be caused. ○ Similarly, the presser steps on the plate, and the upper knife and upper knife lower cover come down. As a result, interference with the throat plate will be caused at the time of feed. ○ The plate interferes with the holding plate and presser foot when the knife works. As a result, breakage or defective motion will be caused. <p>When the thread haul plate is excessively with drawn in the arrow mark direction of D :</p> <ul style="list-style-type: none"> ○ The looper thread at the sewing start runs away from the blade section of knife at the time of thread trimming. As a result, thread trimming failure will be caused. <p>When the thread haul plate is excessively put back to this side (cylinder side) :</p> <ul style="list-style-type: none"> ○ The looper thread at the sewing start runs away from the blade section of knife at the time of thread trimming. As a result, thread trimming failure will be caused. ○ The blade section of upper knife is exposed and material or seams will be cut at the time of thread trimming.

Standard Adjustment

5) Adjusting the position of the upper knife lower cover

1. Hide the blade top of upper knife ⑤. (Blade top is put back by 0 to 1 mm.)
2. Slightly place the slope section to corner section E of lower knife ①.
3. Make the top end of upper knife lower cover ⑭ come in close contact with the bottom face of the upper knife.

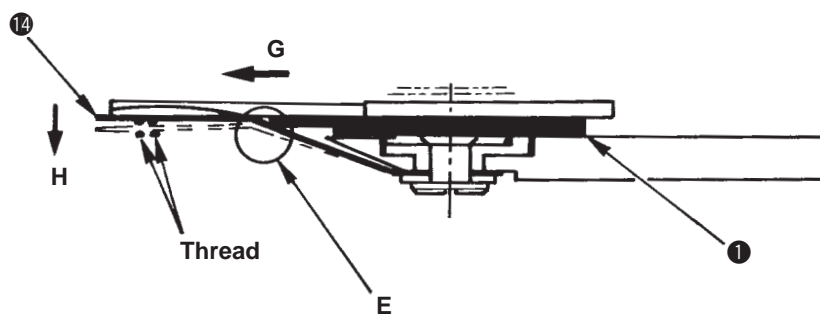
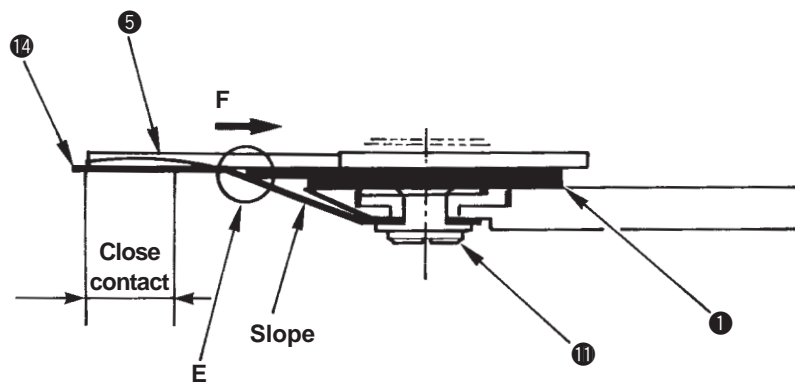
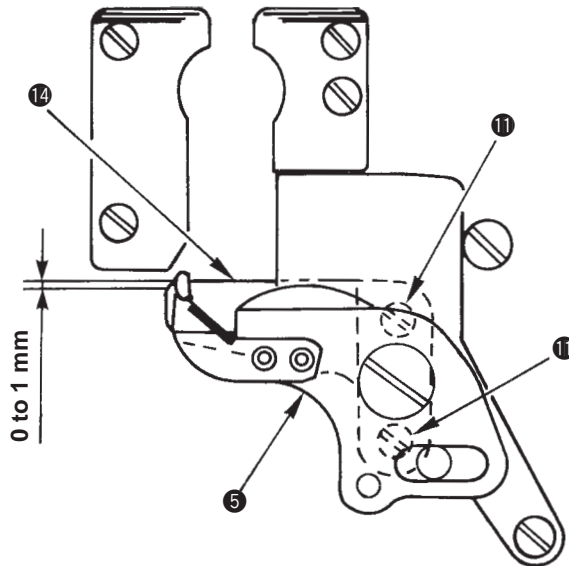

Adjustment Procedures	Results of Improper Adjustment
<p>5) Adjusting the position of the upper knife lower cover</p> <ol style="list-style-type: none"> 1. Loosen two setscrews ⑪ and move upper knife lower cover ⑭ to adjust the position. 2. Adjust the cover so that the blade top of upper knife ⑤ is hidden by 0 to 1 mm. At the same time, move upper knife lower cover ⑭ in the direction of arrow mark F and slightly place the slope section to corner section E of lower knife ①. At this time, the top end section comes in close contact with the bottom face of upper knife ⑤. Slightly correct the upper knife lower cover when the top end section does not come in close contact with the bottom face of the upper knife. <ul style="list-style-type: none"> * When lower knife ① rotates (in the direction of arrow mark G), upper knife lower cover ⑭ bends downward (in the direction of arrow mark H) at corner section E and presses the thread downward. By this operation, looper thread and gimp can be securely trimmed. 3. Fix setscrews ⑪. 4. Check the knife motion. In addition, make sure that upper knife lower cover ⑭ is not caught on the throat plate when the feed base moves back and forth. <p>(Caution) Be sure to adjust the cover when setscrews ⑪ are removed and the knife is removed together with the knife unit in case of the replacement of presser set or the like.</p>	<ul style="list-style-type: none"> ○ When the blade top of upper knife comes out from the upper knife lower cover, the length of remaining thread will be longer or unstable. ○ When the slant face section of upper knife lower cover is detached from corner section E of lower knife, the cover is caught on the throat plate when the feed base moves back and forth. ○ When the slant face section of upper knife lower cover comes in strong contact with corner section E of lower knife, a clearance is provided between the top end section and the upper knife and the cover is caught on the throat plate when the feed base moves back and forth.

(21) Adjusting the needle thread clamp

Standard Adjustment

For the assembling procedure, refer to the Instruction Manual for the needle thread clamp device. The standard adjustment value of the needle thread clamp is as described below. (The optional needle thread guide is different in shape. Refer to 4. -1).

1. The standard adjustment value of longitudinal position of top end ❶ of the clamp is that clearance F between the top end and the screw of the needle bar is 1 mm.
2. Height of top end ❶ of the clamp at the time of lowering is that clearance between the top end and knife cover ❷ is approximately 1 mm at first. (At the time of delivery)
3. Adjust the lateral position of top end ❶ of the clamp approximately to the center of the needle to assemble the clamp.
4. The initial setting of memory switch No. 66 (number of stitches of needle thread clamp open) is 5 stitches. However, increase the setting so as to stabilize the rolling at the sewing start.

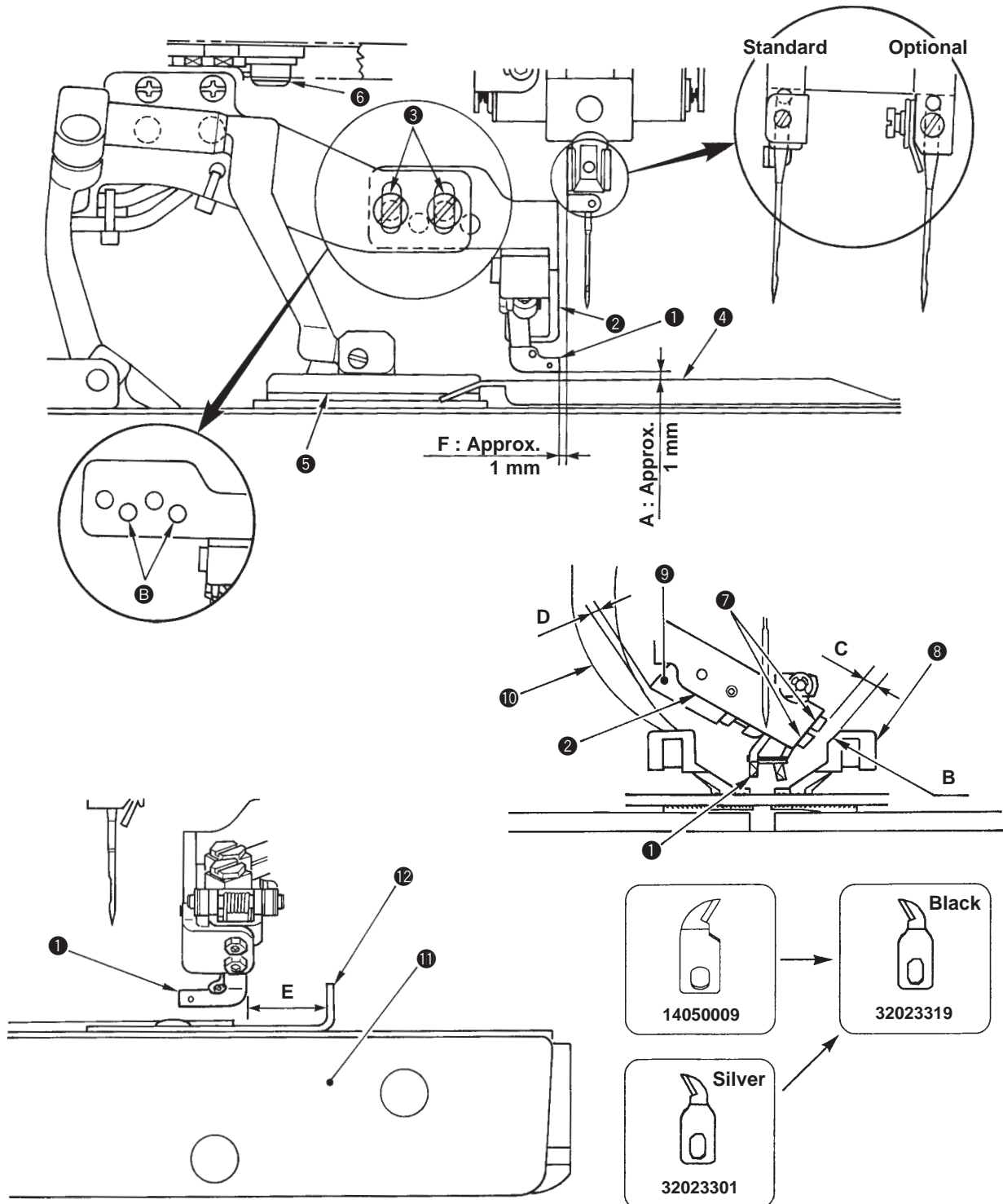

Adjustment Procedures	Results of Improper Adjustment
<p>1. Adjust the height of top end ❶ of the clamp at the time of lowering to the material which is actually sewn, and adjust the height rather lower in the range where the top end does not come in contact with the material. Then the needle thread can be easily rolled in. (When lowering needle thread clamp section ❷, do it after lowering presser ❸ first.) There are two places of adjustment.</p> <ul style="list-style-type: none"> ○ Two setscrews ❸ : These are used for height adjustment. (For the normal adjustment) ○ Two setscrews ❷ : The lateral direction can be simultaneously adjusted. These are used for fine adjustment. <p>(Caution) For the long thread trimming type, there is a case where clearance A between top end ❶ of the clamp and knife cover ❹ is less than 1 mm since the position of the top face of knife cover ❹ is higher.</p> <p>2. Adjust the lateral position of top end ❶ of the clamp to the center of the needle at first and assemble the clamp. Then adjust it while confirming both holding and sewing in accordance with the sewing data to actually sew. (When sewing the straight bartack, adjust top end ❶ of the clamp in terms of the center of the needle to the right side.) There are two places of adjustment.</p> <ul style="list-style-type: none"> ○ Two setscrews ❹ : These are for the device. The whole device can be laterally adjusted. ○ Two setscrews ❷ : The longitudinal direction can be simultaneously adjusted. These are used for fine adjustment. <p>(Caution) 1. When adjusting laterally, make sure of clearance D between presser arm, left ❿ and clamp cylinder ❾, and clearance C between presser foot, right ❸ and setscrew ❷ when the feed moves forward. (There should be a clearance at C and D.)</p> <p>2. In case the eyelet presser foot (short thread trimming type is standard) is used when installing the needle thread clamp after the set-up of the machine, check whether oblique work B is performed on presser foot, right ❸. When the right blade type of needle thread trimming knife is installed, replace the knife with the thread trimming knife J. The length of remaining needle thread becomes short and there is a case where adjustment cannot be performed. In this case, add the oblique work. For the temporary remedy, slightly delay the lowering timing with memory switch No. 67.</p> <p>3. The initial setting of memory switch No. 66 (number of stitches of needle thread clamp open) is 5 stitches. Increase the setting so as to stabilize the rolling at the sewing start while paying attention to the items described below :</p> <ol style="list-style-type: none"> 1) Release needle thread before the the rotary (eyelet) section of stitches. 2) When sewing length is short, or lengthwise guide ❿ is adjusted to the front, set the number of stitches of clamp open so that the clamp lifts before top end ❶ of the clamp interferes with the guide. <p>(Caution) When number of stitches of clamp open is increased, sewing length is shortened, or lengthwise guide ❿ is re-adjusted to the front, make sure of clearance E between top end ❶ of the clamp and lengthwise guide ❿ when the feed moves forward. (There should be a clearance.)</p> <p>4. When installing the needle thread clamp unit on the sewing machine which is not equipped with “needle thread haul two-step function” (without solenoid valve No. 10), take care of the points below. (Perform the same when the optional parts are attached.)</p> <ol style="list-style-type: none"> 1) Change the top end ❶ of clamp to the screw hole on the right side ❺ (detach it from needle), and adjust clearance F between the clamp and the thread tension disk setscrew to 1.5 to 2 mm for the use. 2) Increase the needle thread tension compensation (data No. 53) to shorten the length of remaining needle thread. However, when the length is too short, defective clamp will be caused. <p>(Caution) Do not perform “(22) Adjusting the length of remaining needle thread”. Stitch skipping at the start of sewing will be caused.</p> <p>5. When ROM No. of the sewing machine is not 011* (007A to F), it is necessary to change the ROM. (→ 007G)</p> <p>6. When the needle thread trimming knife of the sewing machine is Part No. 14050009, replace it with Part No. 32023319. (Even in case of Part No. 32023301, it is recommended to replace it with Part No. 32023319 in order to stabilize the length of remaining needle thread.</p>	<ul style="list-style-type: none"> ○ Needle thread may not be completely sewn in if the sewing length is short or the like even when adjusting the position of the clamp or various setting. <p>(Reference) When the length of remaining needle thread is not short enough by the adjustment described in the Instruction Manual, perform the change of setting of either one or both of the memory switches described below :</p> <p>The value in () parentheses is the standard one to change the setting.</p> <ul style="list-style-type: none"> ○ No. 86 (Needle thread trimming ON, lengthwise traveling amount) → (2 to 5) ○ No. 74 (Jump feed speed of thread trimming of lengthwise axis) → (1500) <p>(Caution)</p> <ol style="list-style-type: none"> 1. When the needle thread clamp device is installed after set-up of the machine for the long thread trimming, if the needle (upper) thread trimming knife described in the Instruction Manual is 14050009, the adjustment may not be performed since the length of remaining needle thread becomes short. 2. When the clearance (dimension F : 1.5 to 2 mm) between the optional needle thread guide setscrew and needle clamp screw and top end of the clamp ❶ is not obtained, the needle thread guide setscrew comes in contact with the needle clamp screw, and breakage of the components will result.

(22) Adjusting the length of remaining needle thread

Standard Adjustment

It is the standard to adjust the length of remaining needle thread to a short one so that the clamped thread can be neatly rolled. The sewing machine provided with "needle thread drawing double motion function" can adjust the length of needle thread to clamp to a short one in the following procedure and rolling of the needle thread at the start of sewing can be facilitated. It is possible to roll the thread up to sewing length of approximately 20 mm.

(There is a case where rolling may not be stabilized even in case of 20 mm or more in accordance with the sewing conditions.)

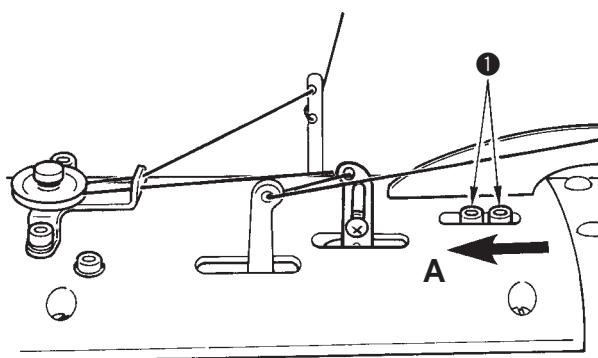

JUKI

(23) Adjusting the feeding amount of the needle thread

Standard Adjustment

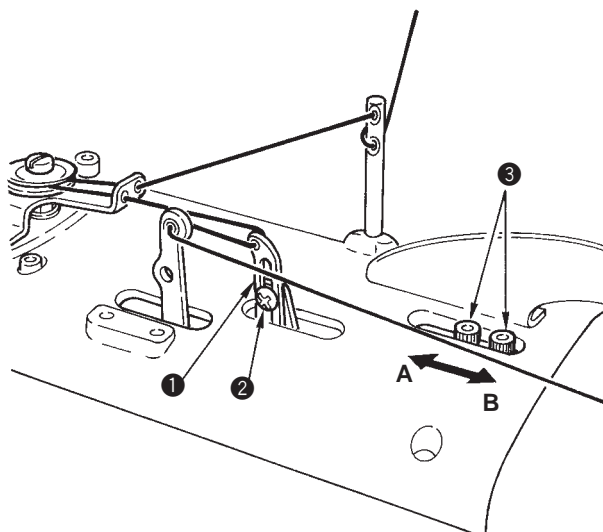

Adjustment Procedures	Results of Improper Adjustment
<p>When the amount of remaining thread is desired to be further shorter, loosen screws ❶, and slide screws ❶ in the direction of arrow mark A.</p> <p>(Cautuion)</p> <ol style="list-style-type: none"> 1. In case of the sewing machine provided with “needle thread drawing double motion function”, set the set value of compensation of needle thread tension (data No. 53) at the time of thread trimming to “0” and use the sewing machine. When the value is set to a higher one, there is a case where the length of remaining needle thread may be unstable. 2. In case of the sewing machine not provided with “needle thread drawing double motion function”, increase the set value of compensation of needle thread tension (data No. 53) to shorten the length of remaining needle thread. 3. In case of the sewing machine not provided with “needle thread drawing double motion function”, adjust the length of remaining needle thread to a longer one for allowance even when the needle bar thread tension disk is removed and the needle thread clamp asm. is installed close to the needle bar. In case of the sewing machine not provided with “needle thread drawing double motion function”, the length of remaining needle thread is shortened by increasing the set value of compensation of needle thread tension (data No. 53) at the time of thread trimming and there is a case where the length of remaining needle thread may be unstable. 4. The needle thread drawing double motion function can be adapted from ROM011D. 	<ul style="list-style-type: none"> ○ When the drawing amount of needle thread is excessively small : <ol style="list-style-type: none"> 1. Thread may slip off needle. 2. Thread knotting failure at the start of sewing may occur. 3. Needle breakage may occur.

Adjustment Procedures	Results of Improper Adjustment
<ol style="list-style-type: none"> 1. Adjusting the feeding amount of the needle thread during sewing <ol style="list-style-type: none"> 1) Loosen screw ❷ and move the position of needle thread hauling thread guide ❶ up and down to adjust the feeding amount. 2. Adjusting the feeding amount of the needle thread at the sewing start <ol style="list-style-type: none"> 1) Loosen screw ❸ and move screw ❸ in the direction of A ↔ B to adjust the amount. 2) When the machine is with needle thread clamp device, if the arm moves in direction A, the length of the needle thread remaining on the needle becomes shorter and rolling can be performed with ease. 	<ul style="list-style-type: none"> ○ If the thread guide slides downward, the feeding amount of the needle thread is decreased and the needle thread is easily tightened. ○ If the thread guide slides upward, the feeding amount of the needle thread is increased and the needle thread is hard to be tightened. ○ If the arm moves in direction B, the hauling amount of the needle thread is increased and slip-off of needle thread or needle breakage can be prevented.

(24) Adjusting the haul amount of the looper thread (long thread trimming/short thread trimming)

Standard Adjustment

1. Long thread trimming type (S/R types)

When looper thread haul driving arm ⑤ moves in the direction A, end C of looper thread haul plate ① is almost vertical.

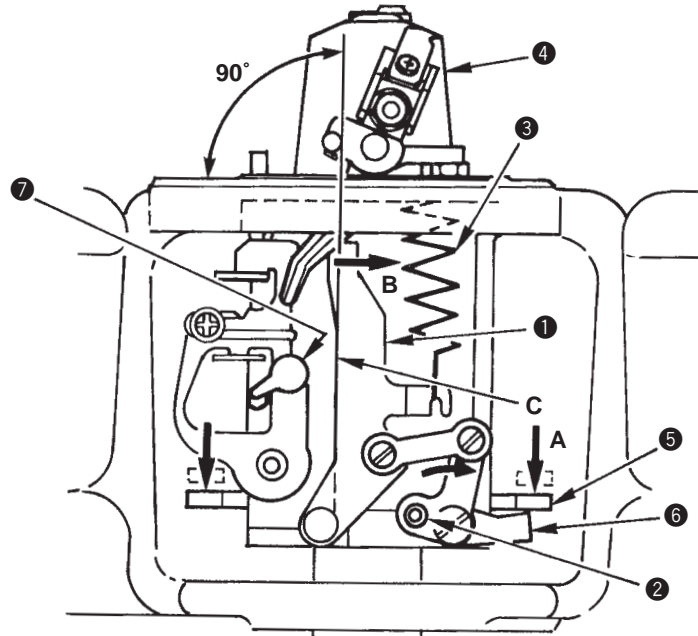

2. Short thread trimming type (J/C types)

When the looper haul mechanism works, end C of the looper thread haul plate is almost vertical.

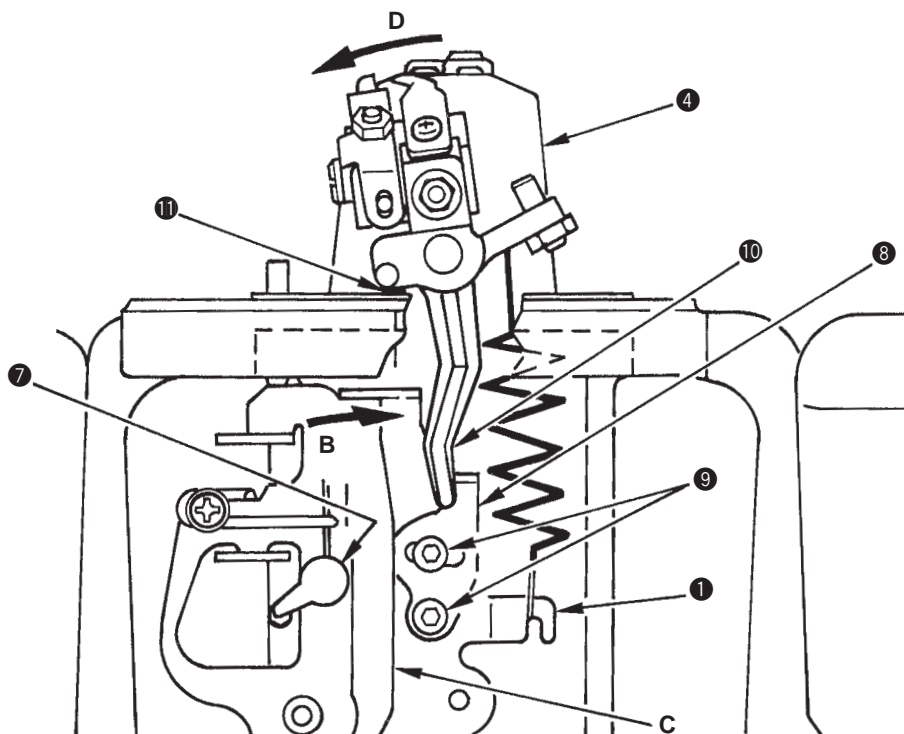

Adjustment Procedures	Results of Improper Adjustment
<p>1. Long thread trimming type (S/R types)</p> <p>1) Turn looper bracket ④ to the front.</p> <p>2) Turn ON the needle thread trimming cylinder with the test mode 2. Looper thread haul driving arm ⑤ moves downward (in the direction of arrow mark A) and presses down link B ⑥. Then looper thread haul plate ① moves in the direction of arrow mark B.</p> <p>3) Loosen setscrew ②, move link B ⑥ and adjust the position of looper thread haul plate ① (= haul amount of looper thread).</p> <p>* When the looper haul is OFF, looper thread haul plate ① comes in contact with stopper ⑦ by means of return spring ③.</p> <p>(Caution) When using the needle thread clamp, in case the clamped needle thread is hard to come out of the material and the remaining amount of needle thread is apt to be unstable, slightly increase the haul amount of looper thread (stroke). Then the thread is apt to easily come out of the material and the length of remaining thread may be stabilized.</p> <p>2. Short thread trimming type (J/C types)</p> <p>1) Turn looper bracket ④ to the front.</p> <p>2) Move needle thread trimming moving arm ⑩ to arrow mark D side by hand until stopper screw ⑪ comes in contact with looper bracket ④. Needle thread trimming moving arm ⑩ presses looper thread haul adjusting plate ⑧ and looper thread haul plate ① in the direction of arrow mark B.</p> <p>3) Loosen setscrew ⑨, move looper thread haul adjusting plate ⑧ and adjust the position of looper thread haul plate ① (= looper thread haul amount).</p>	<ul style="list-style-type: none"> ○ Slightly increase the stroke when the looper thread comes out of the looper thread clamp by the moving of the feed at the sewing start. (In the direction of arrow mark B) ○ Slightly decrease the stroke when the seams of several stitches at the sewing start float (loose stitches). (In the reverse direction from arrow mark B) ○ Slightly increase the stroke when stitch skipping occurs at the first stitch at the sewing start. (In the direction of arrow mark B) ○ Slightly decrease the stroke when the seams of several stitches at the sewing start float (loose stitches). (In the reverse direction from arrow mark B)

(25) Adjusting the looper thread haul driving arm (long thread trimming)

Standard Adjustment

- Long thread trimming type (S/R types only)

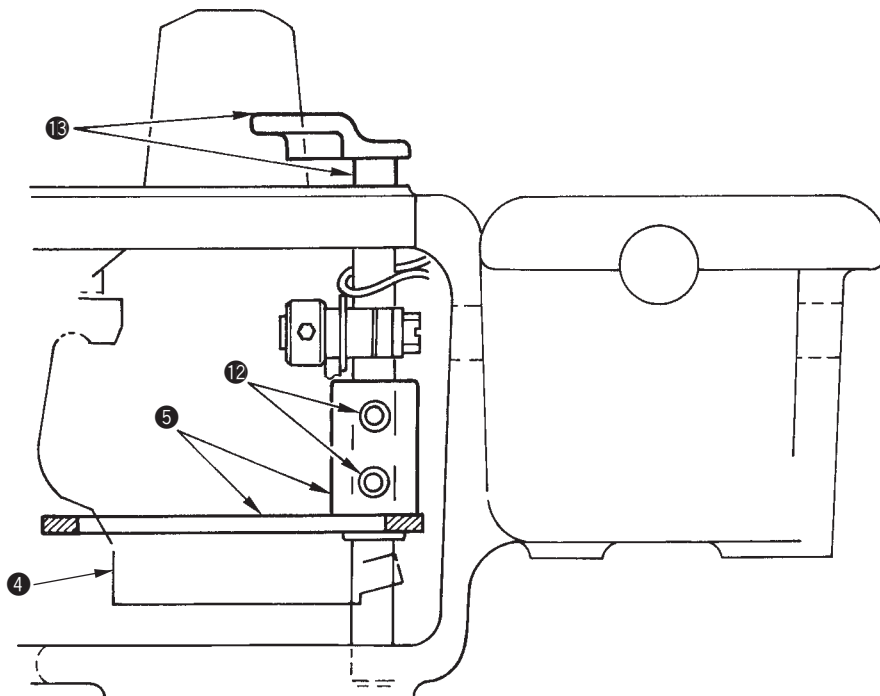
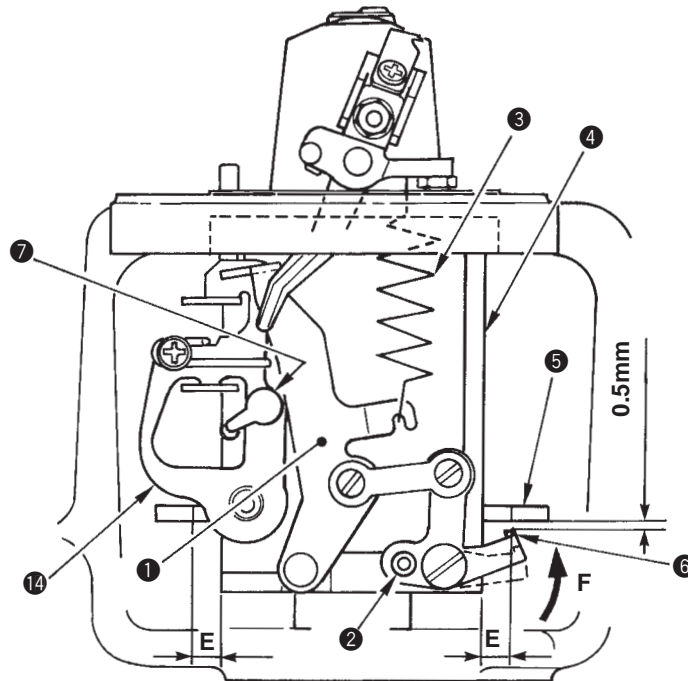

Adjustment Procedures	Results of Improper Adjustment
<p>1. Loosen setscrew ② and fully move link B ⑥ to arrow mark F side (upward) (adjust the haul amount of looper thread to the maximum). Then temporarily tighten setscrew ②.</p> <p>2. Loosen two setscrews ⑫ in looper thread haul driving arm ⑤ and determine the upward/downward and right/left position of looper thread haul driving arm ⑤. Then tighten the setscrews.</p> <p>1) Provide a clearance of 0.5 mm between looper thread haul driving arm ⑤ and link B ⑥ and make clearance E with looper bracket ④ equal on the left and right sides.</p> <p>(Caution) 1. Turn looper bracket ④ by hand and make sure that looper thread haul driving arm ⑤ does not come in contact with the bracket at right/left (section E) and top/bottom positions (clearance of 0.5 mm section).</p> <p>2. When adjusting, perform the adjustment when looper thread haul plate ① comes in contact with stopper ⑦ by means of return spring ③ (looper thread haul OFF). In addition, perform the adjustment in the state that the power is turned OFF and the air pressure is supplied (needle thread trimming vertical moving arm ⑬ is raised).</p> <p>3. Apply a small quantity of grease to the bottom face (contact face with the link B ⑥) of looper thread haul driving arm ⑤.</p> <p>4. Loosen setscrew ② and adjust the haul amount of the looper thread with link B ⑥ referring to the item “(24) Adjusting the haul amount of the looper thread (long thread trimming/short thread trimming)”.</p>	<ul style="list-style-type: none"> ○ If upward/downward clearance of 0.5 mm is larger than the specified value, it is not possible to greatly adjust the haul amount of looper thread. ○ When looper bracket ④ rotates, it comes in contact with looper thread guide ⑭ and defective rotation will be caused. ○ If upward/downward clearance of 0.5 mm is smaller than the specified value, or the parts come in contact with each other, it is not possible to decrease the haul amount of looper thread. ○ When looper bracket ④ rotates, it comes in contact with looper thread haul driving arm ⑤, and defective rotation, occurrence of noise or defective sewing will be caused. ○ If clearance E is not equal on the both sides, when looper bracket ④ rotates, it interferes with looper bracket ④ and looper thread guide ⑭. As a result, defective rotation will be caused. ○ Looper thread haul driving arm ⑤ comes off link B ⑥ according to the angle of looper bracket. As a result, looper thread haul motion failure will be caused.

(26) Adjusting the remaining amount of the gimp (J/C types)

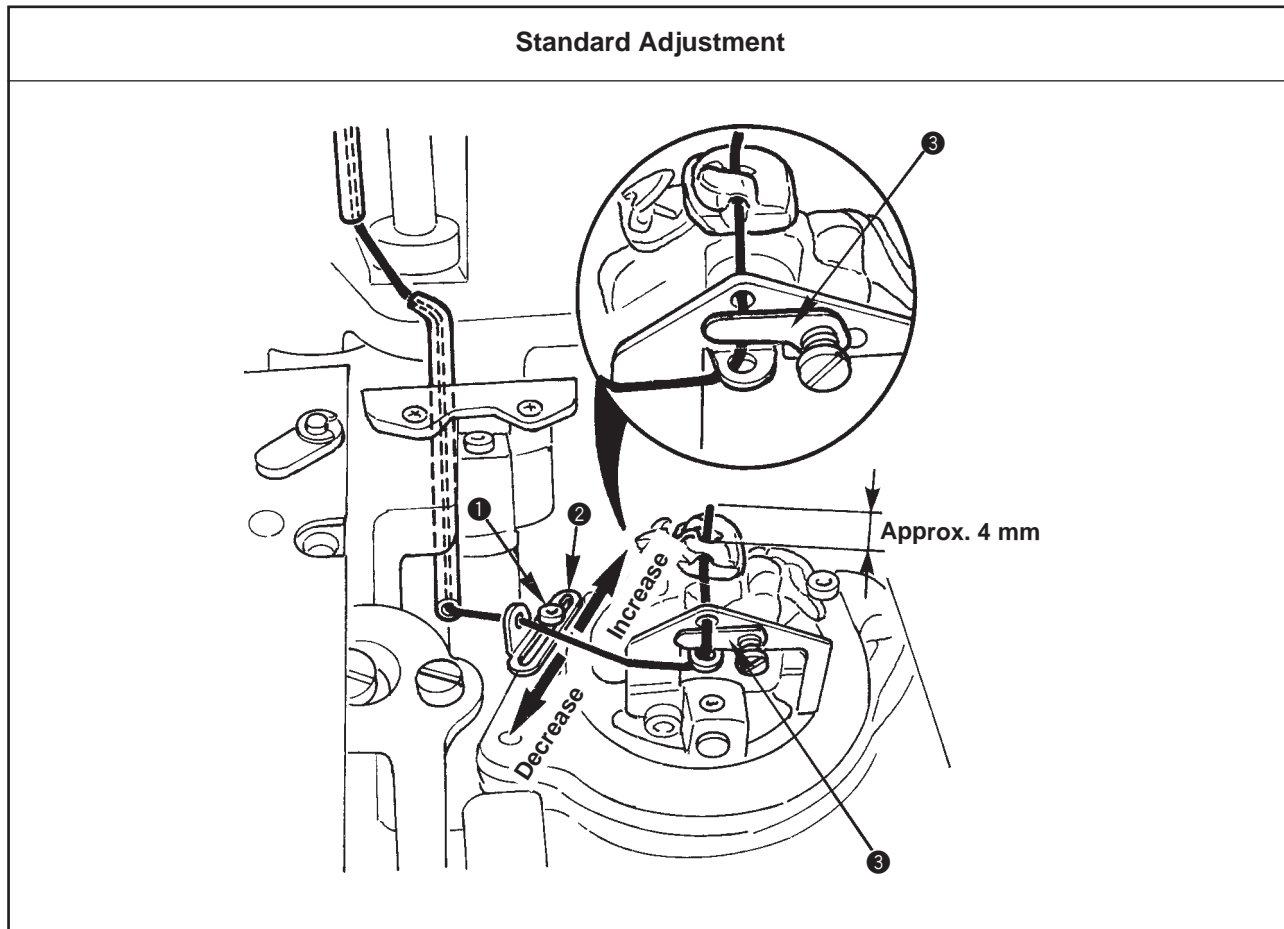

(27) Adjusting the tension of the needle bar rotary timing belt

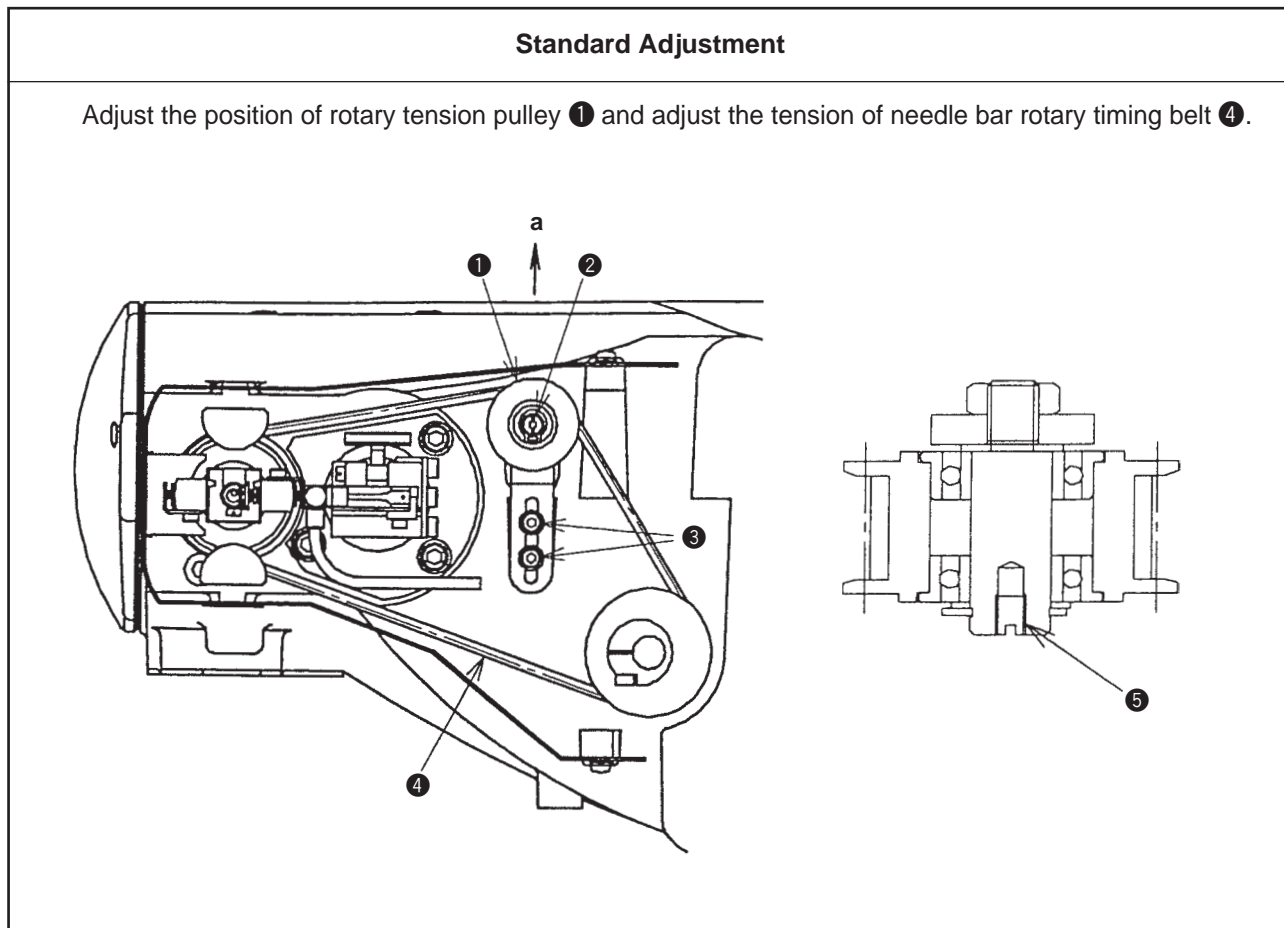

Adjustment Procedures	Results of Improper Adjustment
<ol style="list-style-type: none"> 1. Loosen setscrew ❶ to move to and fro gimp guide ❷ and adjust the remaining amount of the gimp at the end of sewing. 2. To adjust, perform actual sewing on the fabric or the like and determine the position of gimp guide ❷ so that the remaining length of the gimp is approximately 4 mm at the time of completion of sewing. <ol style="list-style-type: none"> 1) When using the sewing thread or the like as the gimp, the remaining amount of the gimp may not be stabilized. In this case, insert the gimp in gimp presser plate ❸. 	

Adjustment Procedures	Results of Improper Adjustment
<ol style="list-style-type: none"> 1. Loosen two setscrews ❸ in the rotary tension pulley installing plate. 2. Hook a spring balancer to rotary tension pulley shaft ❷ and draw the balancer with 14.7N force in the direction of the arrow mark "a". 3. While drawing the spring balancer, tighten two setscrews ❸ in the rotary tension pulley installing plate. <ol style="list-style-type: none"> 1) When measuring the tension, the adjustment of the tension can be performed with ease if a screw or the like to hook the spring balancer is inserted into rotary tension pulley shaft ❷. 2) Screw ❺ for rotary tension pulley shaft ❷ is M3. <p>(Caution) After the adjustment of the tension of the timing belt, make sure of "(6) Clearance between the needle and the looper" without fail.</p>	<p>When the tension is high :</p> <ul style="list-style-type: none"> ○ Needle bar tilts and the relation with the looper is warped. <p>When the tension is low :</p> <ul style="list-style-type: none"> ○ Tooth skipping of the timing belt occurs.

(28) Adjusting the tension of the looper turning timing belt

Standard Adjustment

Adjust the position of turning motor installing plate ② and adjust the tension of needle bar rotary timing belt ④.

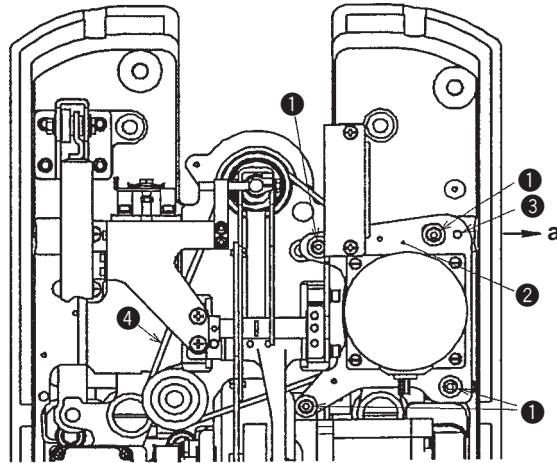

(29) Adjusting the position of the needle bar rotary pulley

Standard Adjustment

Adjust the timing of the needle bar rotary pulley so that the clearance between the needle and the looper when the needle going up from the inside needle lower dead position is aligned with the looper is equal to the clearance between the needle and the looper when the needle coming down to the outside needle lower dead position is aligned with the looper.

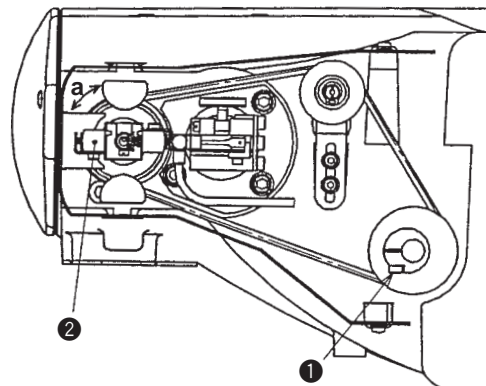

When the needle going up from the inside needle lower dead position is aligned with looper (left)

When the needle coming down to the outside needle lower dead position is aligned with looper (left)

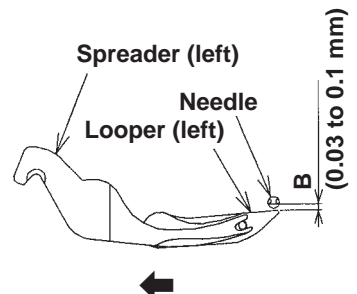
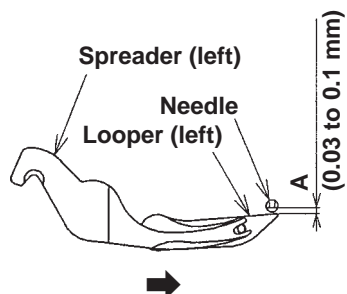
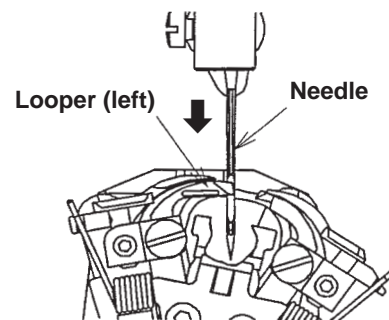
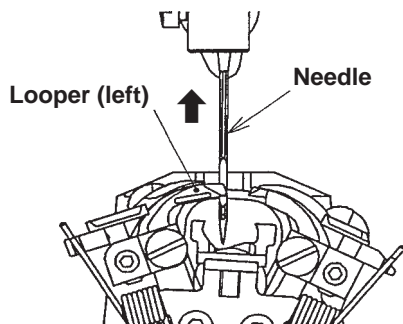

$$A \doteq B$$

Adjustment Procedures	Results of Improper Adjustment
<ol style="list-style-type: none"> 1. Loosen four setscrews ❶ in the turning motor installing plate. 2. Hook a spring balancer to hole ❸ in turning motor installing plate ❷ and draw the balancer with 9.8N force in the direction of the arrow mark “a”. 3. While drawing the spring balancer, tighten four setscrews ❶ in the turning motor installing plate. 	<p>When the tension is high :</p> <ul style="list-style-type: none"> ○ Looper bracket tilts and the relation with the looper is warped. <p>When the tension is low :</p> <ul style="list-style-type: none"> ○ Tooth skipping of the timing belt occurs.

Adjustment Procedures	Results of Improper Adjustment
<ol style="list-style-type: none"> 1. Loosen setscrew ❶ in the rotary connecting pulley. 2. Turn needle bar rotary pulley ❷ in the direction of the arrow mark “a” and adjust so that the clearance between A and B (0.03 to 0.1 mm) is equal while observing the respective clearances of the needle and the looper when the needle going up from the inside needle lower dead position is aligned with the looper and when the needle coming down to the outside needle lower dead position is aligned with the looper. 	<p>When the clearances are not equal :</p> <ul style="list-style-type: none"> ○ Stitch bite width is decreased. ○ Stitches tilt.

(30) Adjusting the position of the looper bracket

Standard Adjustment

Adjust turning sensor slit ② so that marker dot ③ engraved on the machine bed is aligned with marker dot ④ engraved on looper bracket ⑤ at the time of turning origin.

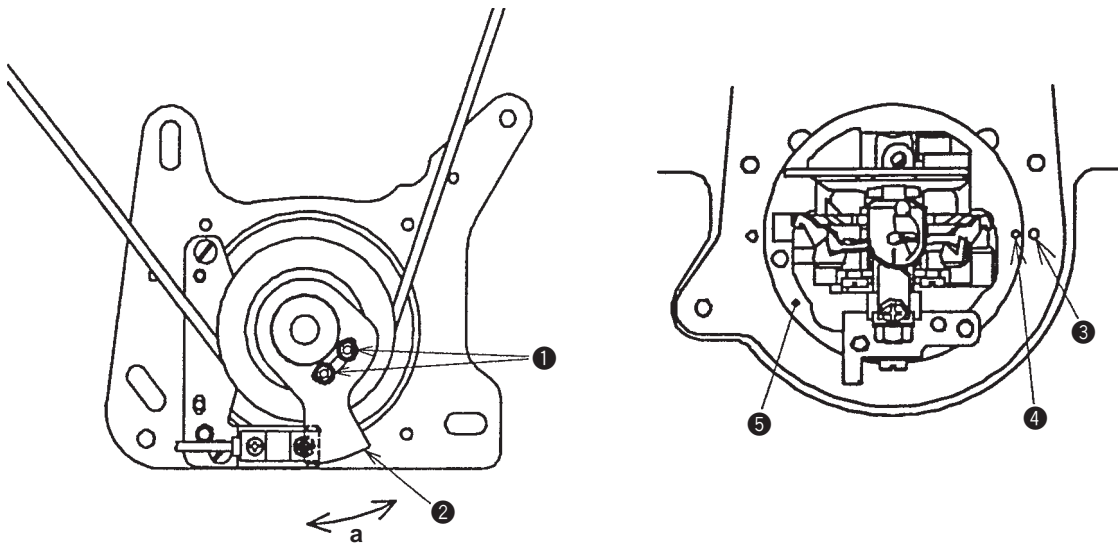

(31) Adjusting the main shaft sensor

Standard Adjustment

Adjust main shaft sensor installing plate ② so that the main shaft sensor detects at the front position of approximately 10° from the upper dead position of the needle bar.

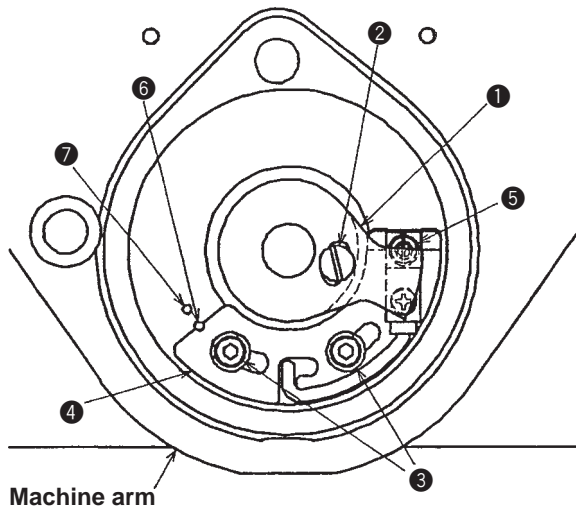

When needle bar is in its upper dead position

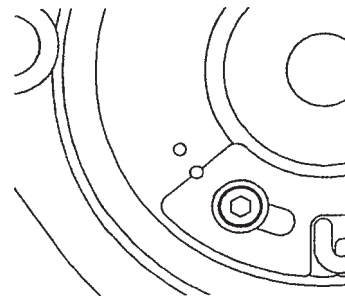

When needle bar is in front of 10° from its upper dead position

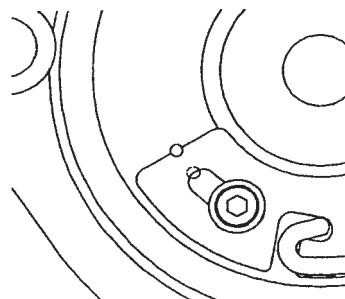

Notch

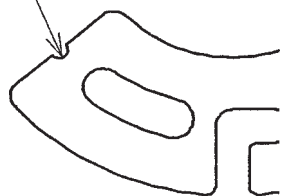

Adjustment Procedures	Results of Improper Adjustment
<ol style="list-style-type: none"> 1. Call Test mode No. 4 and change over to the turning axis (Pattern No. 3). (Refer to “8.-(4) Crosswise feed / lengthwise feed / turning origin check”.) 2. Loosen two setscrews ❶ in the turning sensor slit installing plate. 3. Move turning sensor slit ❷ in the direction of the arrow mark “a” and adjust so that marker dot ❸ engraved on the machine bed is aligned with marker dot ❹ engraved on looper bracket ❺ at the time of turning origin. 	<p>When the marker dots are not aligned with each other :</p> <ul style="list-style-type: none"> ○ Stitches of the parallel section and eyelet section tilt.

Adjustment Procedures	Results of Improper Adjustment
<ol style="list-style-type: none"> 1. Loosen two setscrews ❸ in the main shaft sensor installing plate. 2. Adjust the notch of main shaft sensor installing plate ❹ to marker dot ❻, and temporarily tighten two setscrews ❸ in the main shaft sensor installing plate. 3. Call Test mode No. 1 and change over the pattern No. to No. 19. 4. Turn the main shaft by hand to bring the needle bar to its inside needle upper dead position. 5. Loosen setscrew ❷ in the main shaft sensor slit. 6. Adjust main shaft sensor slit ❶ so that the 4-digit display LED becomes [0111], and tighten setscrew ❷ in the main shaft sensor slit. 7. Loosen again two setscrews ❸ in the main shaft sensor installing plate. 8. Adjust the notch of main shaft sensor installing plate ❹ to marker dot ❼, and tighten two setscrews ❸ in the main shaft sensor installing plate. 	<p>When the main shaft sensor is slipped</p> <ul style="list-style-type: none"> ○ The stop position of the needle bar is lowered.

(32) Adjusting the origin position of the crosswise feed sensor

Standard Adjustment

1. Remove the presser plates, left and right.
2. Turn the looper bracket by 180° after performing the origin retrieval referring to "8.-(4) Crosswise feed / lengthwise feed / turning origin check".
3. Distances, A and B between the edge of step section of throat plate and the feed base are equal to each other. (A, B = 60.2 mm)
A (When the looper bracket is in the origin), B (When the looper bracket base turns by 180°)

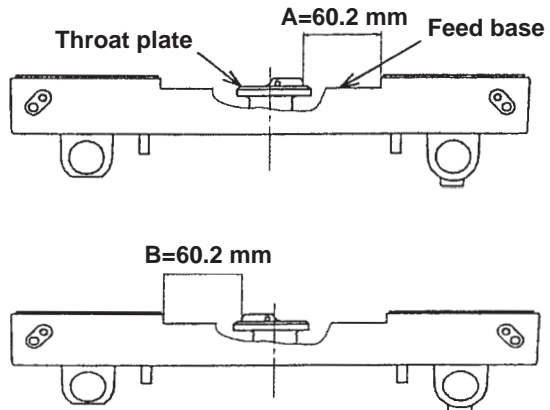
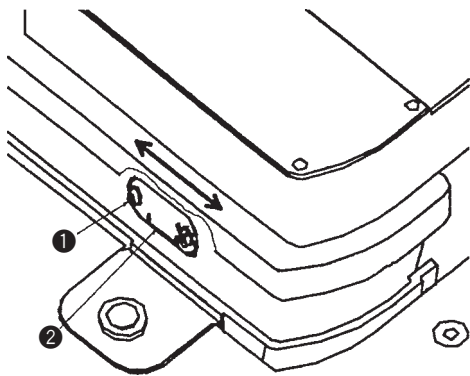

(33) Adjusting the origin position of the lengthwise feed sensor

Standard Adjustment

1. Remove the presser plates, left and right.
2. Perform the origin retrieval referring to "8.-(4) Crosswise feed / lengthwise feed / turning origin check".
3. The distance from the center of the needle to the edge of the cloth open holding pin becomes 51 mm.

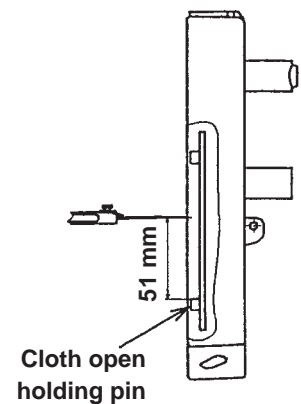
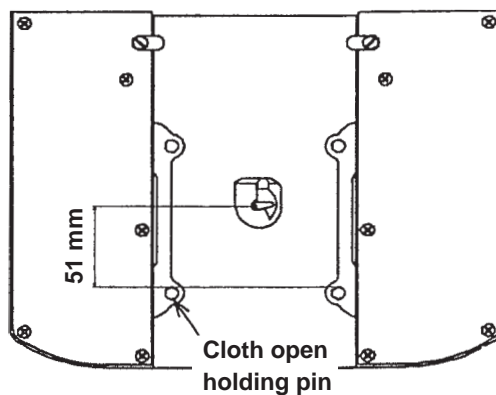
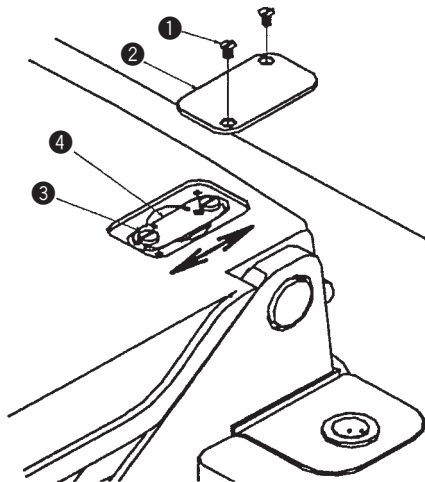

Adjustment Procedures	Results of Improper Adjustment
<ol style="list-style-type: none"> 1. Loosen two setscrews ❶ in the crosswise feed sensor installing plate in the direction of the arrow mark. 2. Perform the origin retrieval and turning of the looper bracket by 180° referring to "8.- (4) Crosswise feed / lengthwise feed / turning origin check". Then confirm that A and B are equal to each other. (A, B = 60.2 mm) 3. Repeat the steps 1. and 2. until A and B become equal to each other. 	<ul style="list-style-type: none"> ○ Presser foot and presser holding plate interfere with needle and throat plate, and feed failure, needle breakage or defective eyelet shape will occur. ○ Shape at the straight section is deformed.

Adjustment Procedures	Results of Improper Adjustment
<ol style="list-style-type: none"> 1. Remove two setscrews ❶ and remove lengthwise feed sensor cover ❷. 2. Loosen two setscrews ❸ and adjust lengthwise feed sensor installing plate ❹ in the direction of the arrow mark. 3. Perform the origin check and make sure of the distance, 51 mm from the center of the needle to the edge of the cloth open holding pin referring to "8.- (4) Crosswise feed / lengthwise feed / turning origin check". 4. Repeat the steps 2. and 3. until the distance from the center of the needle to the edge of the cloth open holding pin. 	<ul style="list-style-type: none"> ○ Presser foot and presser holding plate interfere with needle and throat plate, and feed failure, needle breakage or defective eyelet shape will occur. ○ Shape at the eyelet section is deformed.

(34) Adjusting the cloth cutting origin sensor

Standard Adjustment

Adjust the cloth cutting origin sensor so that the distance between cloth cutting knife ⑨ and knife holder ⑧ should be 20 mm when the cloth cutting mechanism is in the origin sensor position.

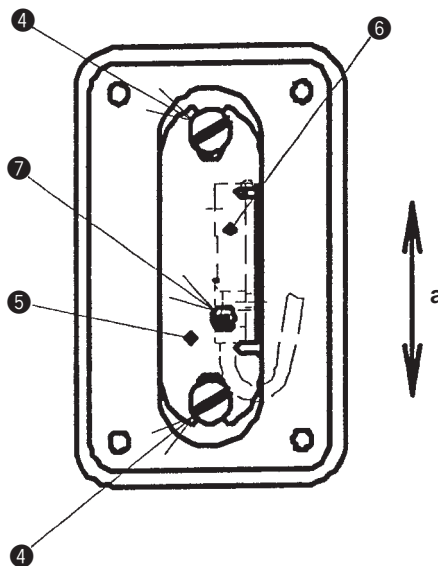
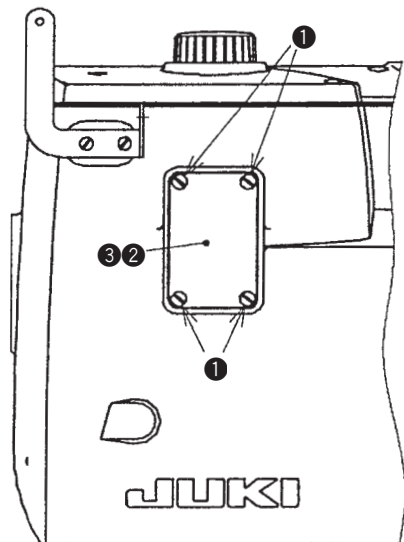

Old

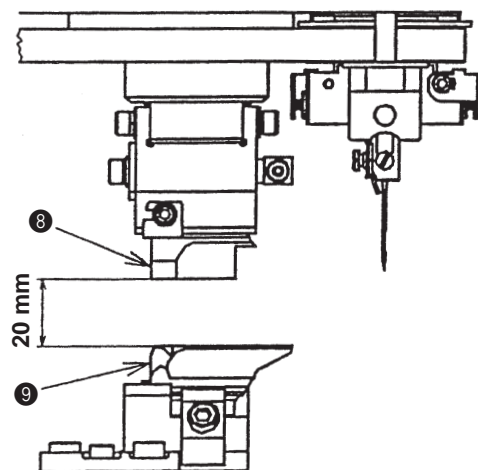

New

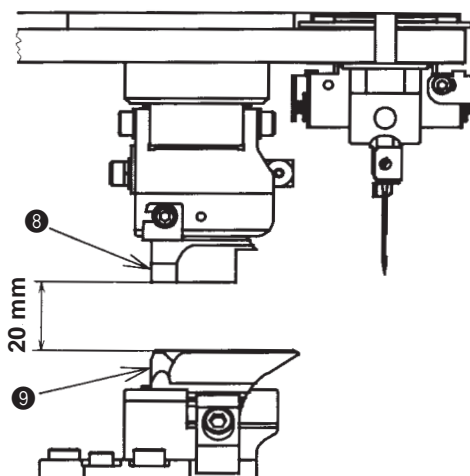

Adjustment Procedures	Results of Improper Adjustment
<p>1) Remove the presser unit, left and right.</p> <p>2) Remove four side cover setscrews ❶, and remove side cover ❷ and side cover packing ❸.</p> <p>3) Call Test mode No. 5 and change over the pattern No. to cloth cutting knife position display (Item No. 1). (See the item "Checking the cloth cutting knife origin.)</p> <p>4) Press [RIGHT ⊕] key of the operation panel and lower knife holder ❸ to the position where knife holder ❸ aligns with cloth cutting knife ❹.</p> <p>5) Press [RIGHT ⊖] key of the operation panel and raise knife holder ❸ by 1,130 pulses (≒ 20 mm) from the position where knife holder ❸ has aligned with cloth cutting knife ❹.</p> <p>Ex. 1 : When knife holder ❸ and cloth cutting knife ❹ have aligned with each other, in the case where the 4-digit LED display of the operation panel is "1250", press [RIGHT ⊖] key and make the 4-digit LED display "120" (= 1250 - 1130).</p> <p>Ex. 2 : When knife holder ❸ and cloth cutting knife ❹ have aligned with each other, in the case where the 4-digit LED display of the operation panel is "1040", press [RIGHT ⊖] key and make the 4-digit LED display "-90" (= 1040 - 1130).</p> <p>6) Change over the pattern No. to the sensor display of Test mode No. 5 (Item No. 0).</p> <p>7) Loosen two setscrews ❷ in the cloth cutting origin sensor installing plate.</p> <p>8) Adjust cloth cutting origin sensor installing plate ❸ in the direction of the arrow mark "a" so that the 4-digit LED display lights up [1]" (LED of cloth cutting origin sensor ❹ lights up from hole ❺ of the cloth cutting origin sensor installing plate).</p> <p>9) Temporarily tighten two setscrews ❷ in the cloth cutting origin sensor installing plate and perform again the origin retrieval of cloth cutting.</p> <p>10) Change over to the cloth cutting knife position display of Test mode No. 5 (Item No. 1) and press again [RIGHT ⊕] key of the operation panel to lower knife holder ❸ to the position where knife holder ❸ aligns with cloth cutting knife ❹. At this time, make sure that the 4-digit LED display of the operation panel is 1120 to 1140.</p> <p>11) If the 4-digit LED display of the operation panel is not within the range of 1120 to 1140, perform again the steps 4. through 9., and adjust so that the display is within the range of 1120 to 1140.</p>	<p>When the position of the cloth cutting origin sensor is slipped :</p> <ul style="list-style-type: none"> ○ Error No. 7 (cloth cutting knife stepping motor origin sensor error) occurs. ○ Step-out of the cloth cutting knife stepping motor may occur. ○ Thread trimming failure occurs. ○ Cloth cutting knife or knife holder may be broken.

(35) Adjusting the backlash of the cloth cutting stepping motor

Standard Adjustment

Adjust the backlash between cloth cutting stepping motor gear ④ and cloth cutting ball screw gear ⑤. Minimize the backlash to such an extent that the backlash does not affect cloth cutting motor ③.

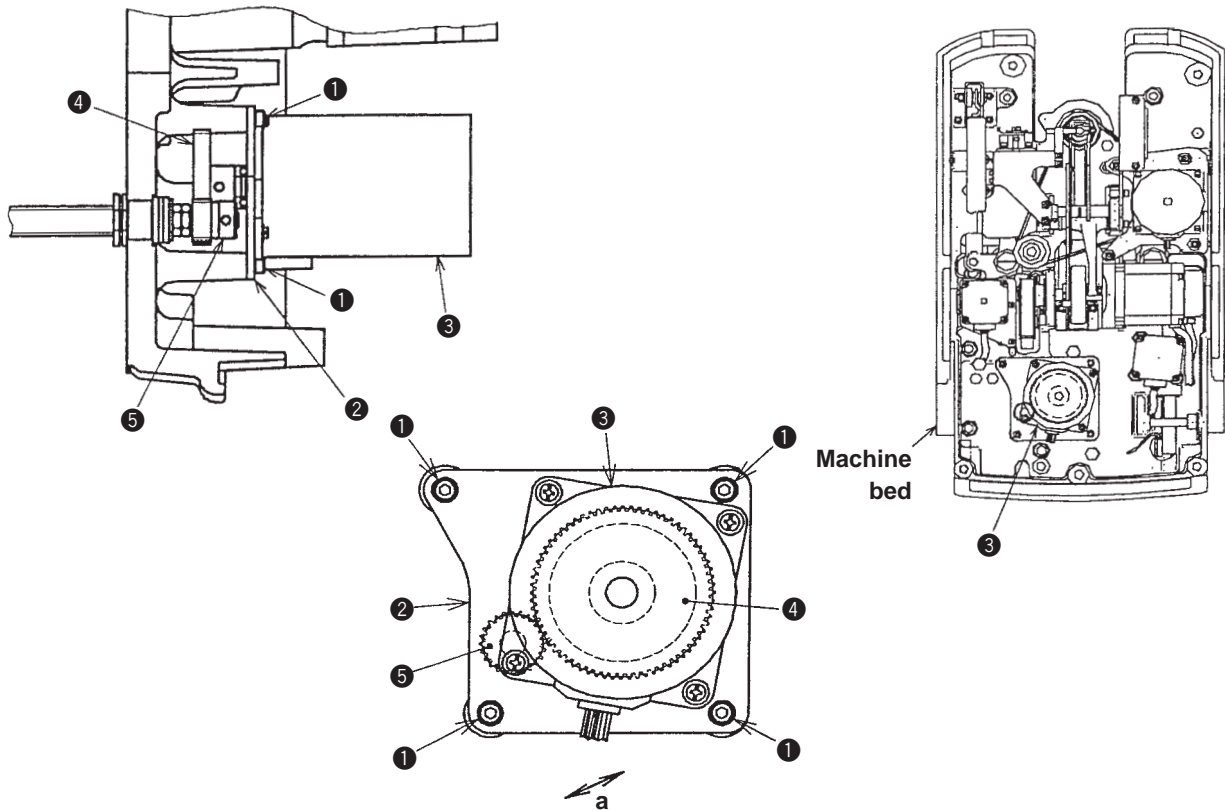

(36) Adjusting the cloth cutting lever stopper

Standard Adjustment

Adjust so that cloth cutting lever stopper ① protrudes 9.5 mm from the top surface of the machine arm.

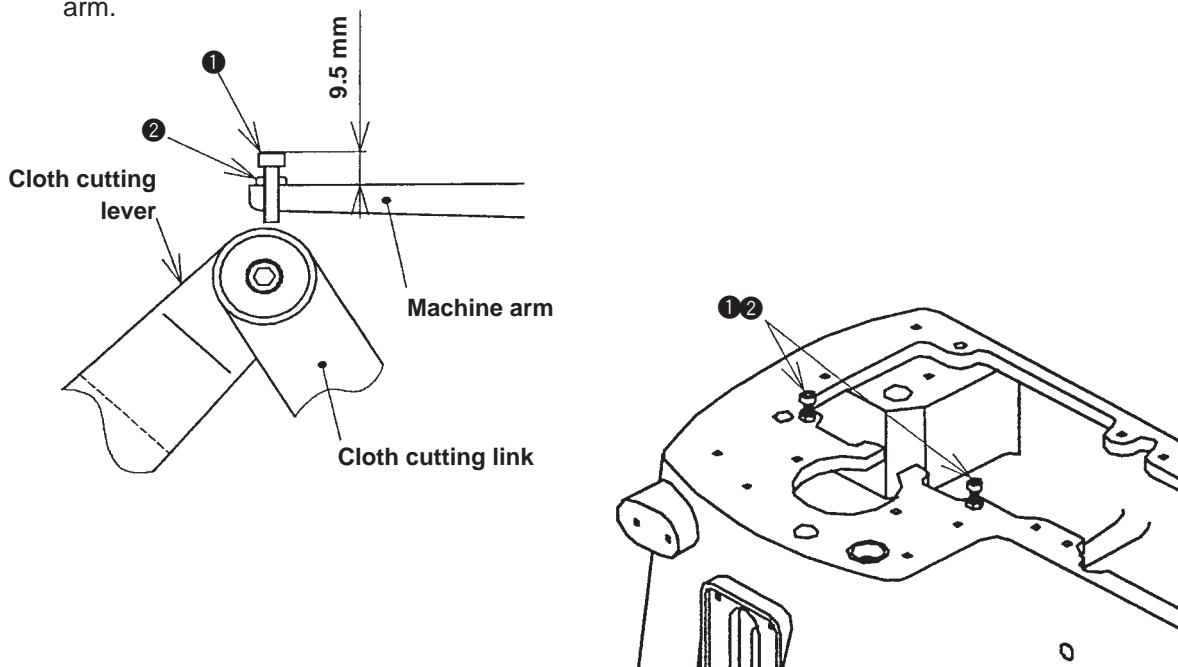

Adjustment Procedures	Results of Improper Adjustment
<ol style="list-style-type: none"> 1. Loosen four setscrews ❶ in the cloth cutting motor installing plate. 2. Move cloth cutting motor installing plate ❷ in the direction of the arrow mark “a” and adjust the backlash between cloth cutting motor gear ❸ and cloth cutting ball screw gear ❹. 	<p>When the backlash is large :</p> <ul style="list-style-type: none"> ○ Operating noise is increased. <p>When the backlash is small :</p> <ul style="list-style-type: none"> ○ Step-out of the cloth cutting stepping motor may occur.

Adjustment Procedures	Results of Improper Adjustment
<ol style="list-style-type: none"> 1. Loosen two nuts ❷ of the cloth cutting lever stoppers. 2. Adjust so that the heads of two cloth cutting lever stoppers ❶ protrude 9.5 mm from the top surface of the machine arm, and tighten two nuts ❷ of the cloth cutting lever stoppers. 	<p>When the head of the cloth cutting lever stopper is low :</p> <ul style="list-style-type: none"> ○ Error No. 7 (cloth cutting origin error) occurs. <p>When the head of the cloth cutting lever stopper is high :</p> <ul style="list-style-type: none"> ○ Other components may be broken.

(37) Adjusting the positions of the lengthwise feed and crosswise feed motor installing bases (Adjusting the backlash of the feed drive gear)

Standard Adjustment

Adjust the respective motor installing bases so that there is no play due to the backlash of the feed drive gear and the feed base smoothly moves when moving the feed base laterally or longitudinally by hand.

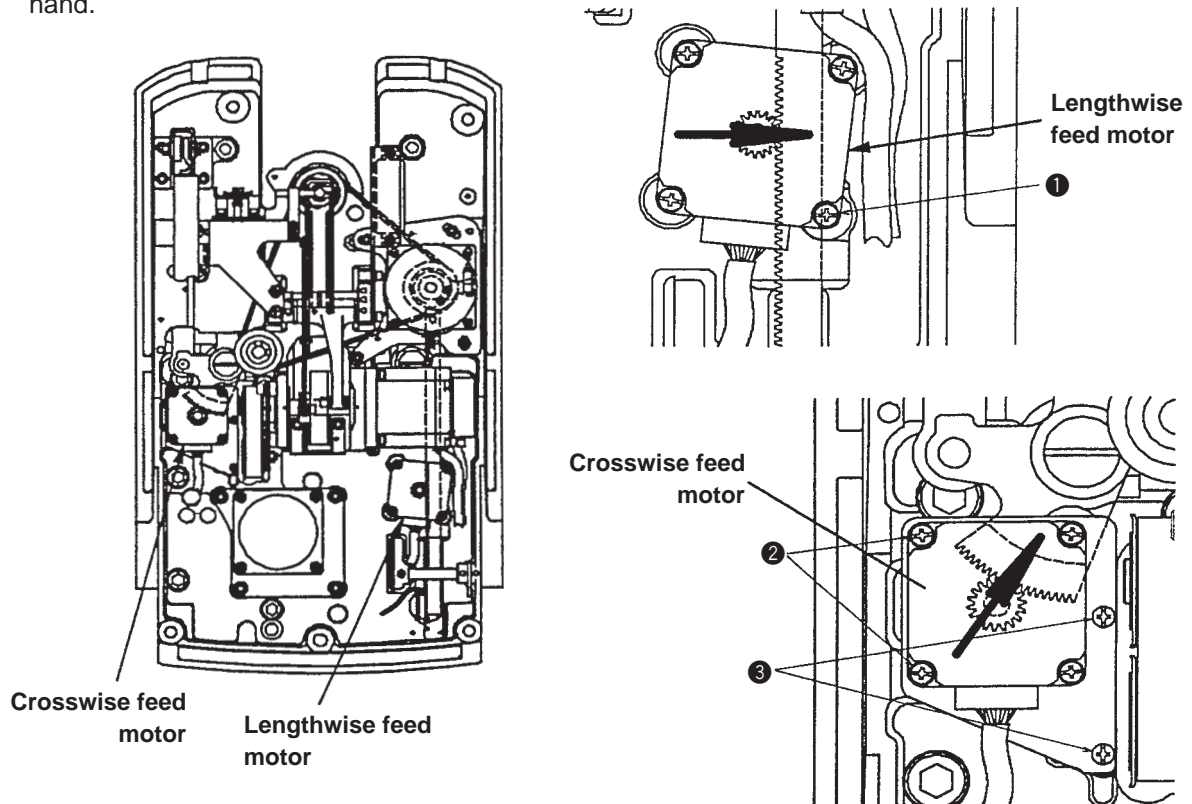

(38) Adjusting the thread take-up thread guide

Standard Adjustment

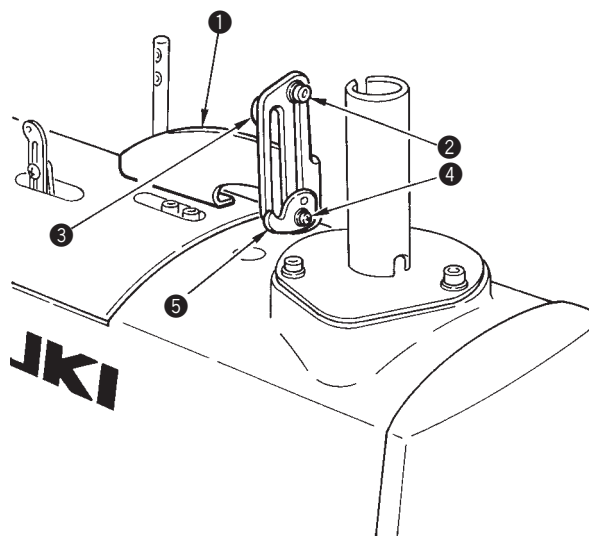

Adjustment Procedures	Results of Improper Adjustment
<ol style="list-style-type: none"> 1. Loosen four setscrews ❶, slightly press the lengthwise feed motor in the direction of the arrow mark (→), and tighten again four setscrews ❶. 2. Loosen two setscrews ❷ and two setscrews ❸, slightly press the crosswise feed motor in the direction of the arrow mark (→), and tighten again two setscrews ❷. 	<p>When the backslash is large :</p> <ul style="list-style-type: none"> ○ Defective feed occurs and accuracy of needle entry position is deteriorated. As a result, sewing pattern is deformed. <p>When the pressing is too strong :</p> <ul style="list-style-type: none"> ○ When the pressing is too strong, load of feed is increased and defective feed occurs.

Adjustment Procedures	Results of Improper Adjustment
<ol style="list-style-type: none"> 1. The tendencies described on the right-hand side can be obtained by sliding up and down thread take-up thread guides ❸ and ❺ attached to thread take-up thread guide installing base ❶. 2. Loosen screw ❷ to move thread take-up thread guide ❸ in the downward direction. 3. Loosen screw ❹ to move thread take-up thread guide ❺ in the upward direction. 	<p>Move downward thread take-up thread guide ❸.</p> <ol style="list-style-type: none"> 1. Stitches of double chain-stitch are easily able to stand and the range of sewing possible area is widened. On the contrary, the whole stitches become stiff. (This adjustment is for the heavy-weight materials.) 2. Loops when the looper catches become large. As a result, stitch skipping can be prevented. (In case of hard-to-slide thread) <p>Move upward thread take-up thread guide ❺.</p> <ol style="list-style-type: none"> 1. Stitches of double chain-stitch become flat and stitches become soft. On the contrary, the range of sewing possible area is narrowed and stitch skipping is apt to occur. (This adjustment is for the light-weight materials.)

(39) Adjusting the active tension

Standard Adjustment

1. Preparation

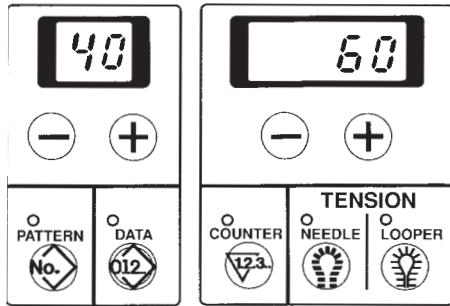

2. Looper thread active tension

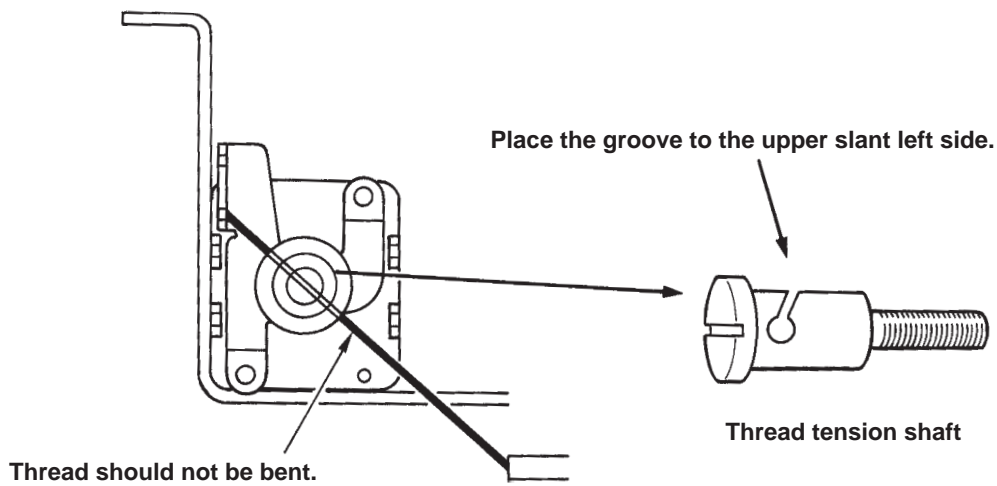
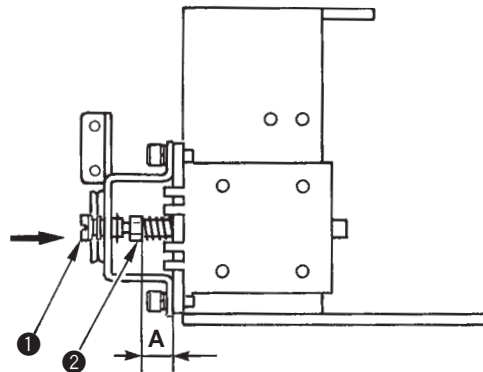

3. Needle thread active tension

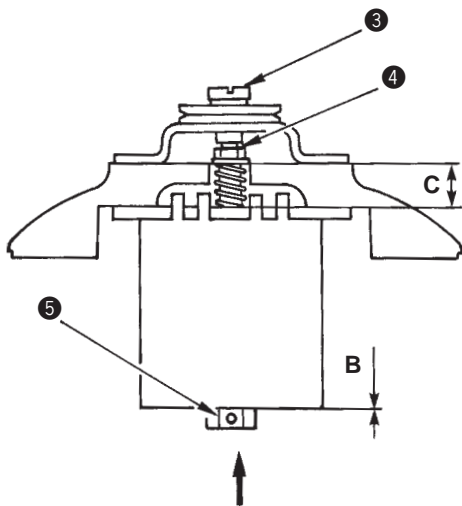

4. Re-setting of the memory switch

1. Measure again whether thread tension (U and D) measured at the step 1. Preparation can be output at the time of the same needle thread/looper thread tension setting "60" and "50" after re-adjustment or assembling. When the error is large, perform re-setting of memory switches "E7" (needle thread) and "E8" (looper thread) of the level 2.

Adjustment Procedures

Results of Improper Adjustment

1. Preparation

Measure the actual thread tension U and D before performing disassembling or assembling adjustment. Perform the measurement by setting needle thread tension "60"/ looper thread tension "50" and using the thread tension gauge or the like.

	Setting on operation panel	Actual thread tension
Needle thread (No. 40)	"60"	U
Looper thread (No. 60)	"50"	D

2. Looper thread active tension

- 1) In the state that AT thread tension shaft ❶ is pressed in the disk closing direction (in the direction of arrow mark), tighten or loosen AT thread tension shaft ❶ so that length A of the magnet shaft becomes approximately 10.5 mm and fix the shaft with nut ❷.
- 2) There is a groove where thread passes in AT thread tension shaft ❶. This groove is required to adjust it to the direction where thread passes.

(Caution) Place the cutting edge of the groove to the upper slant left side and be careful that thread is not bent.

3. Needle thread active tension

- 1) Press the magnet shaft from the rear of the magnet (in the direction of arrow mark), and fix thrust collar ❸ so that length C of the magnet shaft becomes 11 mm.
- 2) Tighten AT thread tension shaft ❹ so that clearance B between thrust collar ❸ and the magnet becomes 0.5 mm when the disk is closed, and fix it with nut ❺.
- 3) Turn OFF the power and make sure that the rising amount of disk is 0.5 mm.

4. Re-setting of the memory switch (Re-setting procedure)

- 1) When the set value is larger than the setting "60" (or "50") and U (or D) is output, add the difference to the value of E7 or E8.
- 2) When the set value is smaller than the setting "60" (or "50") and U (or D) is output, deduct the difference from the value of E7 or E8.

(Example) In the case where operation panel setting (No. 40) is "75", which is the same value as U measured in the step 1. Preparation when re-measuring needle thread tension :

U = 60, 75 - 60 = 15 Difference of panel set value)

Add "15" to the original value of memory switch "E7".

If the original value of "E7" is "72", set to "72" + "15" = "87".

(Example) In the case where operation panel setting (No. 60) is "30", which is the same value as D measured in the step 1. Preparation when re-measuring looper thread tension :

D = 50, 30 - 50 = -20 (Difference of panel set value)

Deduct "20" from the original value of memory switch "E8".

If the original value of "E8" is "72", set to "72" - "20" = "52".

(Caution) If the original thread tension (U, D) should not have been measured in the step 1. Preparation, perform the aforementioned measurement at the time of re-setting using tetoron thread #30, and setting U = 75g and D = 55g. Note, however, that a few difference will occur.

- If length A of the magnet shaft is larger than the specified value, thread tension in terms of the set value is likely to be higher, and if the length is smaller, the thread tension is likely to be lower.

- If length C of the magnet shaft is larger than the specifies value, thread tension in terms of the set value is likely to be lower, and if the length is smaller, the thread tension is likely to be higher.

- If the rising amount of disk is larger than the specified value, thread tension in terms of the set value is smaller, and if the amount is smaller, the thread tension is higher.

- Even if the thread tension setting is the same, there is a difference between the finish of sewing before and after performing disassembling or assembling adjustment.

(40) Adjusting the cloth cutting knife pressure

Standard Adjustment

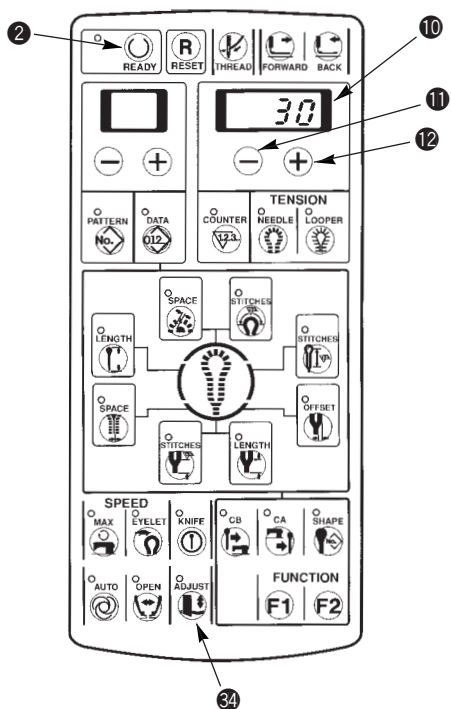

- When replacing the cloth cutting knife or the knife holder, or changing the sewing material, the pressing amount of the knife or the stopping time of the knife lower position can be changed.

(Caution) When the sewing machine is provided with the multicutting device, refer to “15. MULTICUTTING DEVICE”.



















- Making the pattern data of the knife adjustment value
 1. Knife holder No. 0 to 9 to which knife adjustment value can be individually set are set and knife holder No. can be set to the pattern data. Knife adjustment value can be set by starting the knife adjustment mode when turning ON the power.
 2. It is possible to set the knife adjustment value even when starting the memory switch mode since the knife adjustment value itself can be stored in the memory switch.



Knife adjustment value 0 (memory switch No. 50) of knife holder No. 0



Knife adjustment value 1 to 9 (memory switch No. 41 to 49) of knife holder No. 1 to 9

Adjustment Procedures	Results of Improper Adjustment
<ul style="list-style-type: none"> ○ Adjusting the knife pressing amount <ol style="list-style-type: none"> 1. Pressing [ADJUST ] key , turn ON the power. 2. The pressing amount set in 4-digit LED  is displayed. (30 has been set in the state of the standard delivery.) 3. The pressing amount can be set with [RIGHT ] key  or [RIGHT ] key . <p>The setting range is -100 to 300. The more the number is, the higher the knife pressure becomes.</p> 4. Press [READY ] key  to light up the sewing LED. At this time, the feed base performs origin retrieval. 5. Lower the presser with the presser switch and press the start switch to actuate the knife. <ol style="list-style-type: none"> 1) The pressing amount can be set again using [RIGHT ] key  or [RIGHT ] key  with the presser raised. 2) The set value is stored in memory when the knife is actuated by the start switch or [ADJUST ] key  is pressed. When turning OFF the power without performing either operation, the setting is not stored in memory. ○ Adjusting the stopping time of the knife lower position <ol style="list-style-type: none"> 1. The stopping time at the knife lower position can be extended. 2. Setting of 50 to 500 ms can be performed with the memory switch No. 55. (See the item "7. Setting the memory switch".) 	<ul style="list-style-type: none"> ○ Set the knife pressing amount as small as possible in order to protect the knife and the knife holder and maintain the durability. <p>If the knife pressing amount is excessively large, malfunction of the drive motor or breakage of the knife will be caused.</p> ○ Even when the pressing amount is increased, the result is not effective, when the cut length is excessively long or sewing heavy-weight materials, set the stopping time of the knife lower position longer than the specified time.
<ul style="list-style-type: none"> ○ Making the pattern data of the knife adjustment value <ol style="list-style-type: none"> 1. Setting of the knife holder No. pattern setting acceptable <p>Knife holder No. pattern can be set to the memory switch No. 40.</p> <p>0 ... Used for knife holder No. 0 only</p> <p>1 ... Knife adjustment value of knife holder No. 0 to 9 can be individually set for each pattern data.</p> 2. Setting of the knife adjustment value memory switch <p>Memory switch No. 50 ... Knife holder No. 0</p> <p>Memory switch No. 41 to 49 ... Knife holder No. 1 to 9</p> 3. Knife adjustment mode operation <ol style="list-style-type: none"> 1) Knife holder No. pattern setting acceptable <p>Pressing [ADJUST] switch, turn ON the power.</p> <p>Display knife holder No, 0 in the 2-digit LED and knife adjustment value 0 (memory switch No. 50) of knife holder No. 0 in the 4-digit LED, then light up the knife adjustment LED and knife On/Off LED. Perform the origin retrieval by "READY" switch to move the cloth cutting knife and presser/rotary to the position of origin. Light up the ready LED. Lower the presser by the presser switch and actuate the cloth cutting knife using the start switch. At this time, if the knife adjustment value is updated, write it to EEPROM. Update the knife holder No. (2-digit LED) by +1 with [LEFT ] switch and by -1 with [LEFT ] switch, and display the knife adjustment value. Update the knife adjustment value (4-digit LED) by +1 with [RIGHT ] switch and by -1 with [RIGHT ] switch. When the value is updated, it is not stored in memory unless the cloth cutting knife is actuated. When the knife holder No. is updated without actuating the cloth cutting knife, it is not stored in memory. The mode moves to the normal mode by the [ADJUST] switch. At this time, the knife adjustment value is updated, write it to EEPROM.</p> 2) Knife holder No. pattern setting unacceptable <p>2-digit LED is blank.</p> 4. Setting of the knife holder No. pattern data <ol style="list-style-type: none"> 1) Knife holder No. pattern setting acceptable <p>Setting of the knife holder No. to data No. 28</p> <p>Setting range is 0 to 9.</p> 2) Knife holder No. pattern setting unacceptable <p>Setting of the knife holder No. to Data No. 28 is skipped. Data No. is not displayed.</p> 	

5. DISASSEMBLY/ASSEMBLY

(1) Disassembling the needle bar driving gear

Procedures of disassembling/assembling

1. Loosen setscrew ⑩ and pull out rock link shaft ⑪. (Separation of rock link ⑥ and needle bar arm ⑫)
2. Loosen two setscrews ① and two setscrews ③.
3. Pull out needle bar driving shaft ②.
Needle bar driving shaft spacer ⑨ → needle bar driving gear ⑧ → rock bearing ⑦ → rock link ⑥ → needle bar driving shaft spacer ⑤ → needle bar driving shaft thrust collar ④ → needle bar driving shaft ②

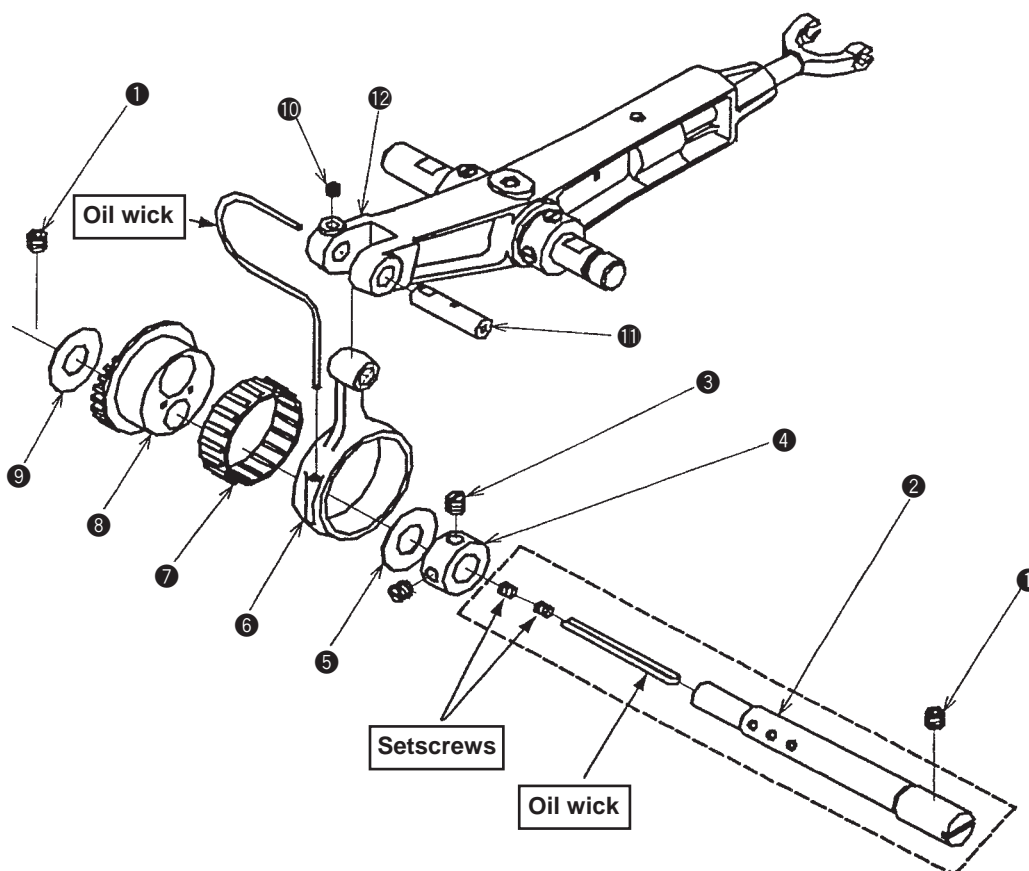

Cautions in assembling

1. Assemble needle bar driving gear ⑧ after performing the alignment of marker dots with the thread take-up lever cam.

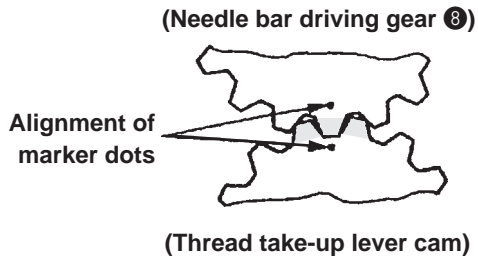

(Caution) White painting is applied to the periphery of the tooth corresponding to the marker dot engraved on needle bar driving gear ⑧ and to the peripheries of the teeth on the both sides corresponding to the marker dot engraved on the thread take-up lever cam.

2. Refer the backlash of the gear to “5.- (3) Adjusting the backlash of the needle bar driving gear”.
3. Select a suitable rock bearing ⑦ so that there is no play between the bearing and rock link ⑥.

Part No. of the rock bearing

Part No.	Diameter of needle
SB33500020A	+ 0.004 mm
SB33500020B	+ 0.002 mm
SB33500020C	Standard
SB33500020D	- 0.002 mm
SB33500020E	- 0.004 mm

4. 1) Pressing needle bar driving shaft ① in direction B, make the step section come in contact with plane A of the machine arm and fix the shaft.
- 2) Pressing needle bar driving shaft thrust collar ④ in direction B and fix it so that the play in the thrust direction does not occur between needle bar driving shaft spacer ⑨, needle bar driving gear, rock link ⑥ and needle bar driving shaft spacer ⑤.

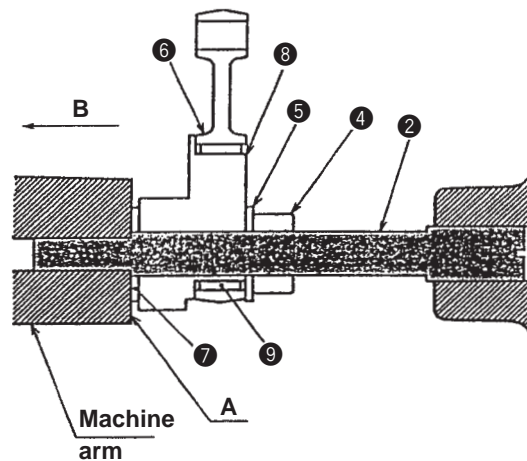

(2) Disassembling the needle bar arm

Procedures of disassembling/assembling

1. Remove rock link shaft ①. Refer the disassembling procedure to "5.-(1) Disassembling the needle bar driving gear".
2. Loosen two setscrews ②.
3. Loosen two setscrews ③ and two setscrews ⑤.
4. Pull out needle bar arm fulcrum shaft ⑧.
Needle bar arm thrust collar ④ → needle bar arm ⑦ → needle bar arm thrust collar ⑥.
5. Pull out needle bar arm ⑦ from needle bar fork ⑨.

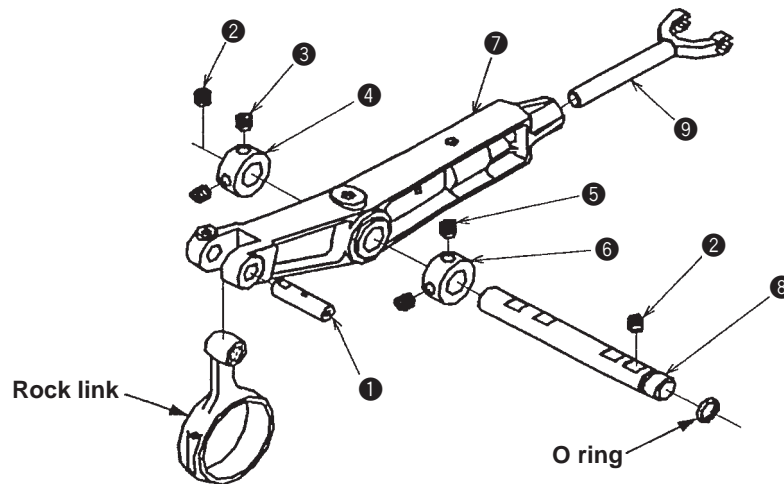

(3) Adjusting the backlash of the needle bar driving gear

Standard Adjustment

Minimize the backlash of needle bar driving gear ③ to such an extent that it does not affect the main shaft torque.

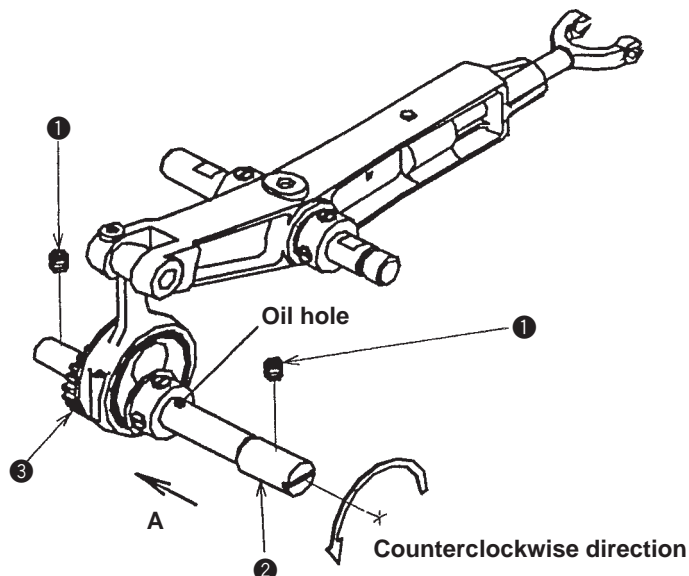

Cautions in assembling

1. Put needle bar arm thrust collars ④ and ⑥ between needle bar arm ⑦ so that there is no play in the lateral direction and fix the needle bar arm.
2. Perform the alignment of the rock link with the center of needle bar arm ⑦, adjust needle bar arm fulcrum shaft ⑧ to the left or right so that the needle bar arm smoothly moves and fix the needle bar arm.

(Caution)

1. Adjust setscrews ②, ③ and ⑤ to the plane of needle bar arm fulcrum shaft ⑧ and fix them.
2. When inserting needle bar arm fulcrum shaft ⑧ into the machine arm, apply grease to it to protect O ring from being torn off.

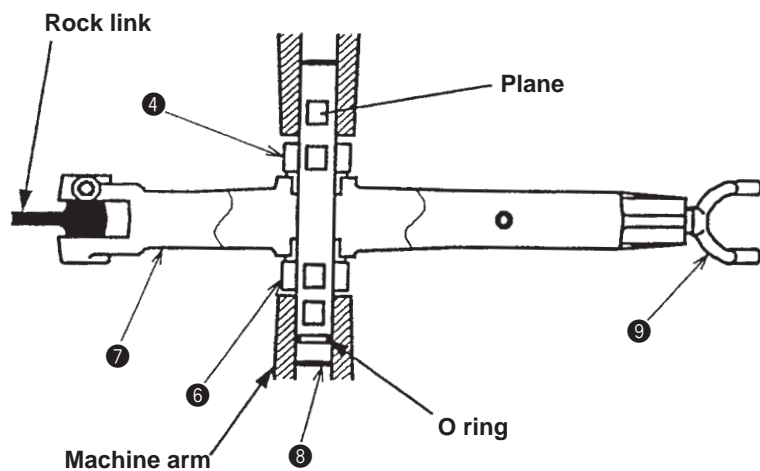

Adjustment Procedures	Results of Improper Adjustment
<ol style="list-style-type: none"> 1. Loosen two setscrews ①. 2. Turn needle bar driving shaft ② in the counterclockwise direction to adjust the backlash of needle bar driving gear ③. (Needle bar driving shaft ② is an eccentric shaft.) 3. Pressing needle bar driving shaft ② in direction A so that the play does not occur in needle bar driving gear ③, adjust the backlash. Then fix the gear with two setscrews ①. <p>(Caution) Be sure to adjust so that the oil hole faces to the upward.</p>	<p>When the backlash is large :</p> <ul style="list-style-type: none"> ○ Vertical play of the needle bar is increased. As a result, stitch skipping or thread breakage will be caused. ○ Operating noise is increased.

(4) Disassembling the cloth cutting mechanism

Procedures of disassembling/assembling

1. Turn cloth cutting dial ① to make cloth cutting lever ② level.
2. Loosen two setscrews in thrust collar ③ and remove thrust collar ③.
3. Remove setscrew A ④ in the cloth cutting lever, setscrew B ⑤ in the cloth cutting lever, setscrew A ⑥ in cloth cutting direct drive gear and setscrew B ⑦ in the cloth cutting direct drive gear.
4. Pull out cloth cutting driving shaft ⑨ in the direction of the arrow mark "a" and remove cloth cutting lever ② and cloth cutting direct drive gear ⑧.

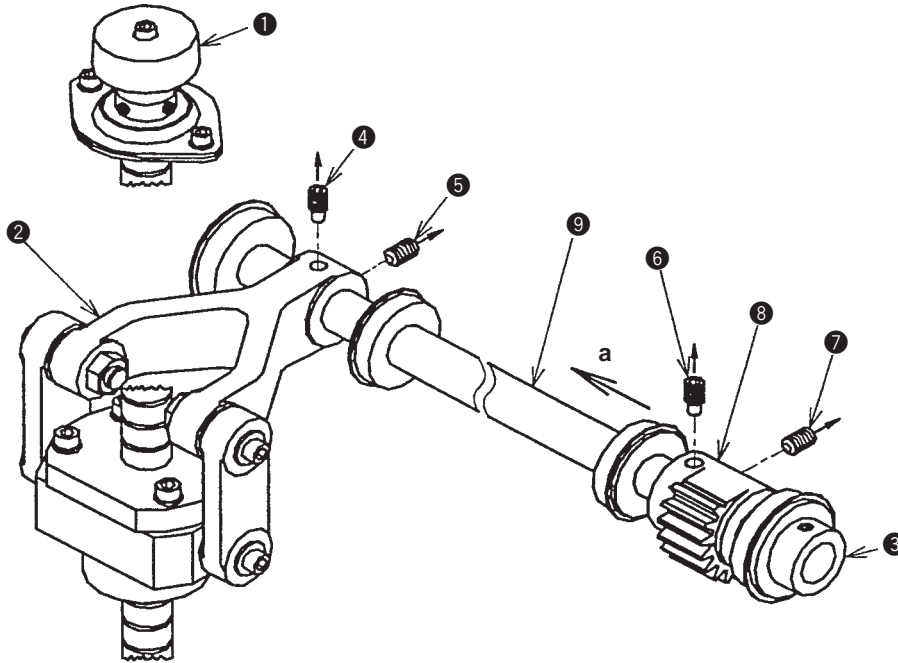

(5) Installing the cloth cutting plate

Procedures of disassembling/assembling

Use cloth cutting plate A for SS/RS types and cloth cutting plate B for JS/CS/TS types .

1. Install the cloth cutting plate so that round hole ④ of cloth cutting plate A or round hole ⑥ of cloth cutting plate B is set to spring pin ② attached to knife base ①, and long hole ⑤ of cloth cutting plate A or long hole ⑦ of cloth cutting plate is set to spring pin ③.

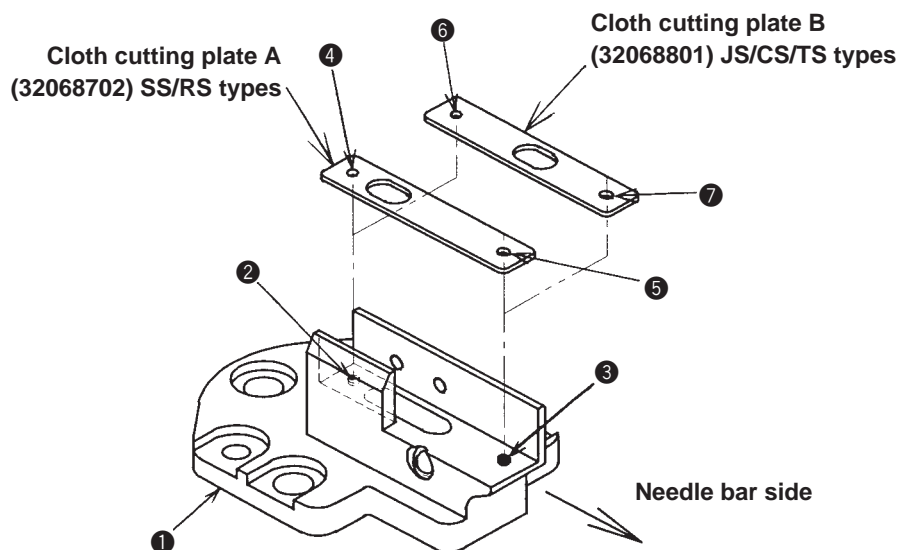

Cautions in assembling

1. Perform the alignment of marker dot V on cloth cutting direct drive gear ⑧ with marker dot W on cloth cutting direct drive metal ⑩.
2. Adjust the tapered sections of setscrew A ④ in the cloth cutting lever and setscrew A ⑥ in cloth cutting direct drive gear to tapered holes, T and U in cloth cutting driving shaft ⑨ respectively.

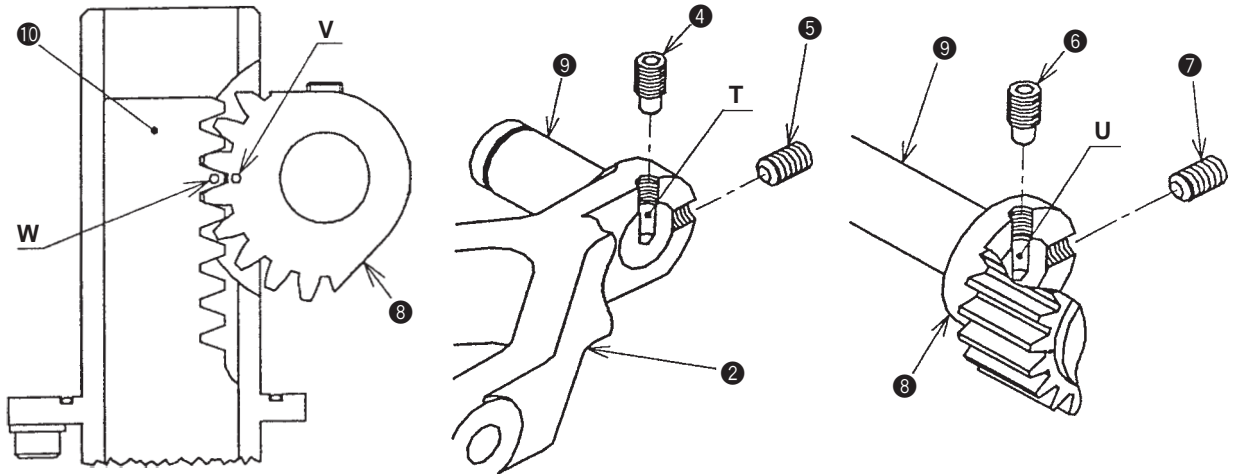

Cautions in assembling

When the combination of the type (SS/RS, or JS/CS/TS) and the cloth cutting plate (A, or B) is wrong, discharge of cloth chips may not be performed well.

(6) Replacing the main shaft timing belt

Procedures of disassembling/assembling

1. Remove the needle and the top cover.
2. Raise the machine head and remove the crosswise feed motor.
Remove two screws ② and ③ described in the item "(37) Adjusting the position of the lengthwise feed motor installing base".
3. Loosen two screws ⑳ in tension pulley installing plate ⑱ and loosen the belt tension. (In the reverse direction from arrow mark E)
4. Remove the setscrew and remove arm lubricating plate ⑩.
5. Widen the backlash of the gear of needle bar drive ⑮ referring to the item "5 - (3) Adjusting the backlash of the needle bar driving cam".
6. Loosen two setscrews each ⑬, ⑫ and ⑪ in thread take-up cam ⑥, needle bar rocking cam ⑤ and main shaft pulley ②.
There is a flat work on the screw No. 1 side only (position of pin G in the direction of arrow mark H) on main shaft ③.
7. Remove the setscrews and draw out hand pulley ⑧. Loosen setscrew ⑭ in main shaft collar ⑦ (it is possible for the screw No. 1 to be on the flat work of main shaft ③) and move slightly main shaft ③ in the direction of arrow mark B.
(This step is the preparation work to make it easy to remove C ring ④ of the next work.)
8. Remove C ring ④. Further, before performing the next work, insert a packing such as cloth or the like between thread take-up cam ⑥ and cloth cutting shaft ⑨ (section C). Assembling is easy since the thread take-up cam is fixed and cam roller ⑮ of thread take-up ⑰ does not drop.
9. Move main shaft ③ to the mid-way point in the direction of arrow mark A and remove main shaft pulley ② only.
10. Remove main shaft timing belt ①.

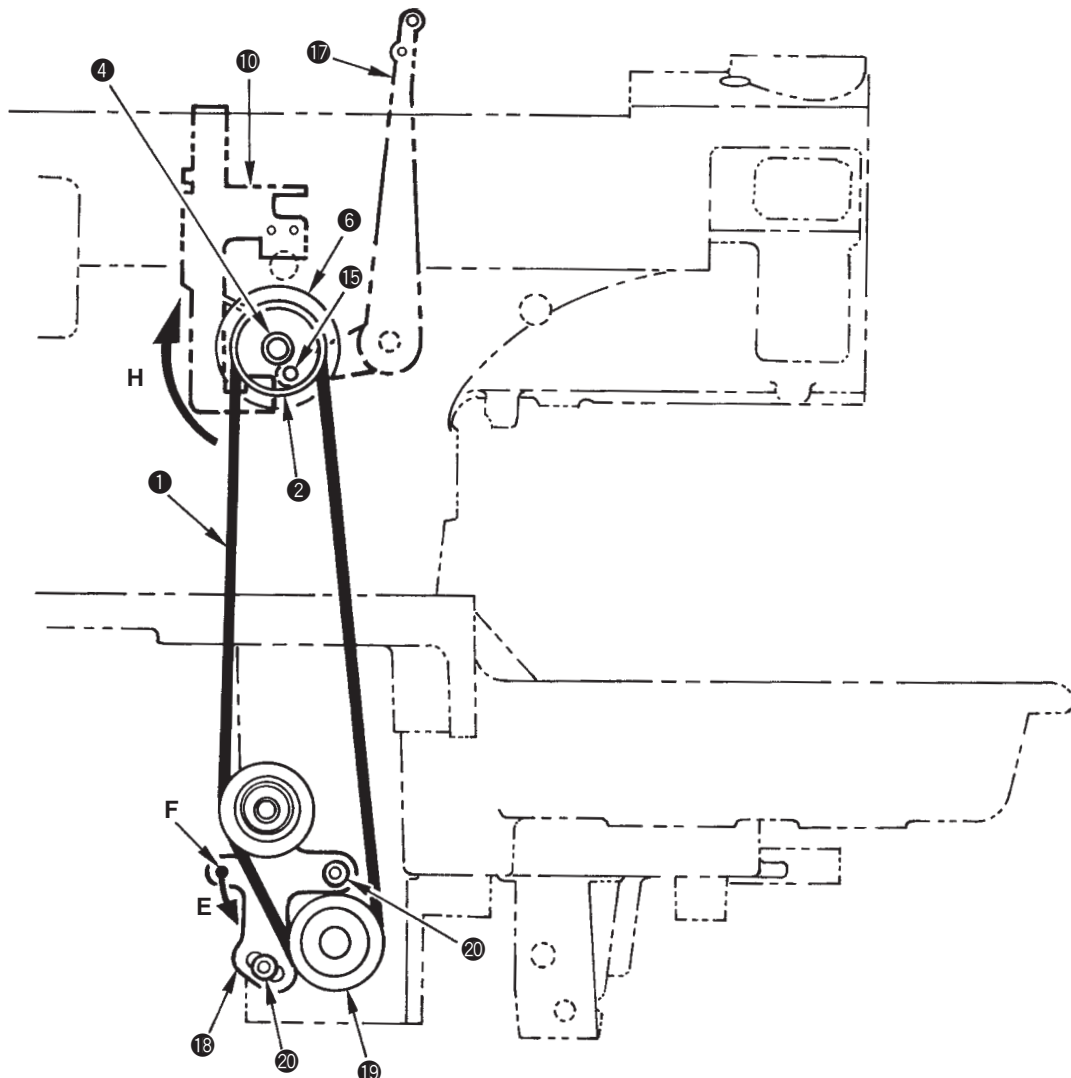

Caution in assembling

1. Place main shaft timing belt ① on main shaft pulley ② in advance and return main shaft ③ in the direction of arrow mark B to assemble the timing belt.
2. After attaching C ring ④, move main shaft ③ in the direction of arrow mark A and remove the thrust with main shaft collar ⑦ so that a play does not occur.
3. When tightening the respective setscrews in thread take-up cam ⑥, needle bar rocking cam ⑤, main shaft pulley ② and main shaft collar ⑦, tighten them so that the screw No. 1 is placed on the flat work of main shaft ③.

Further,

- 1) When tightening the setscrew of thread take-up cam ⑥, make sure that thread take-up cam roller ⑮ is placed in the cam groove. In addition, provide a few clearance (K) between the attaching section of thread take-up cam roller ⑮ of thread take-up ⑰.
If there is no clearance, occurrence of motion torque or worn-out of parts will be caused.
 - 2) When tightening setscrew ⑫ in needle bar rocking cam ⑤, perform it by turning main shaft ③ and making sure that there is no torque.
 - 3) When tightening screws ⑳ in tension pulley installing plate ⑱, perform it while applying belt tension. The standard value of belt tension is 27.4N in the direction of arrow mark E (downward direction to the machine bed) at hole section F of tension pulley installing plate ⑱. If the tension is excessively high or low, breakage of belt or defective sewing will be caused.
4. Adjust the gear backlash of needle bar drive ⑯ referring to the item "5 - (3) Adjusting the backlash of the needle bar driving gear".
 5. After assembling, perform the looper timing adjustment (adjustment of looper cam).

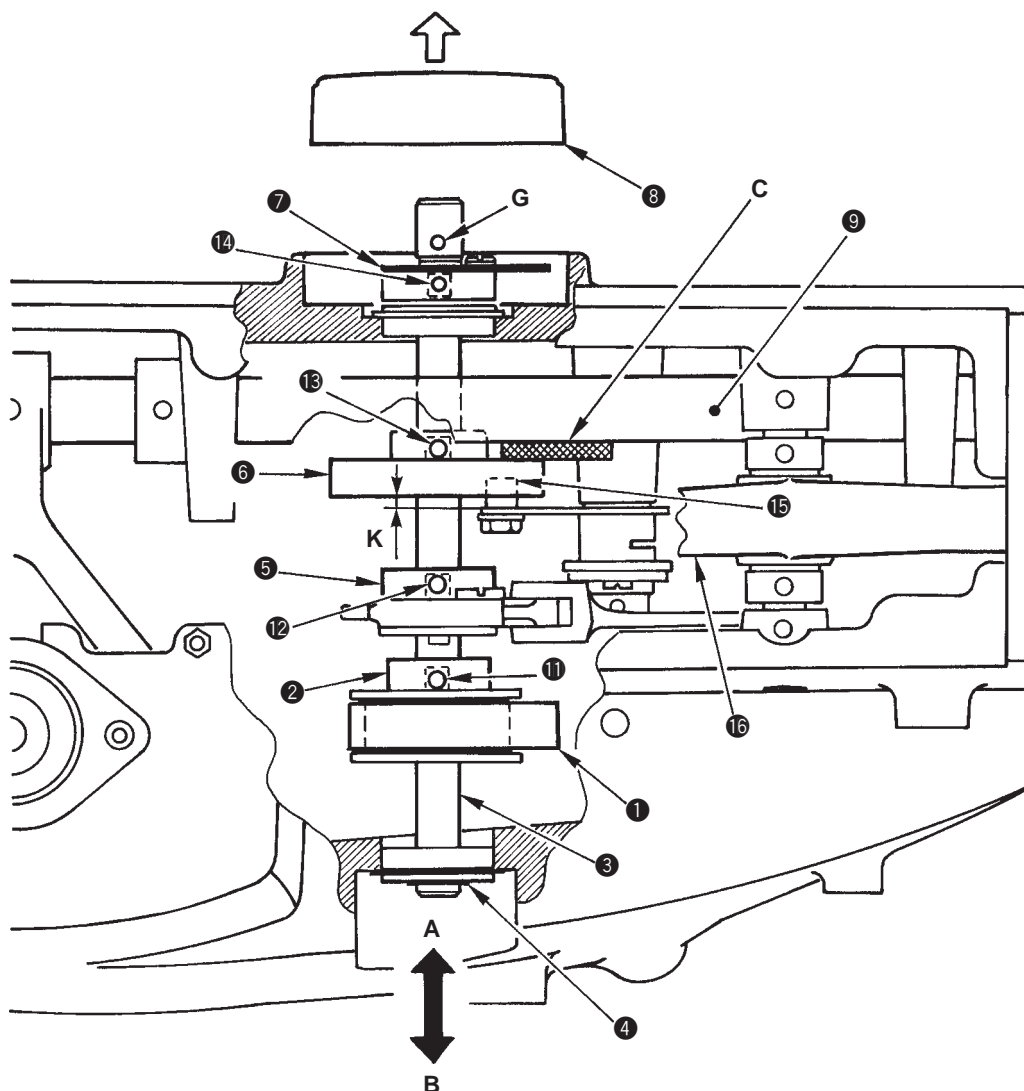

(7) Replacing the needle bar rotary upper timing belt

Procedures of disassembling/assembling

1. Remove the needle and the face cover.
2. Raise the machine head, remove two setscrews ① and two setscrews ②, and remove rotary cover ③.
3. Loosen two setscrews ⑮, move rotary tension pulley ⑭ and loosen the tension of needle bar rotary timing belt ⑬.
4. Loosen clamp screw ⑨ in rotary upper pulley ⑧, two setscrews ⑪ in thrust collar ⑩ and two setscrews ⑯ in rotary lower pulley ⑫, and move rotary shaft ⑱ downward (in the direction of arrow mark B) until rotary upper pulley ⑧ comes off.
(One each of the flat work is on the position of setscrew ⑪ of thrust collar ⑩ of rotary shaft ⑱, and on the position of setscrew ⑯ of rotary lower pulley ⑫.)
5. Loosen setscrew ⑥ and draw out downward rotary pulley support B, left and right, ⑦ (in the direction of arrow mark A).
6. Remove two setscrews ④ and remove rotary pulley support A ⑤ to remove needle bar rotary timing belt ⑬.

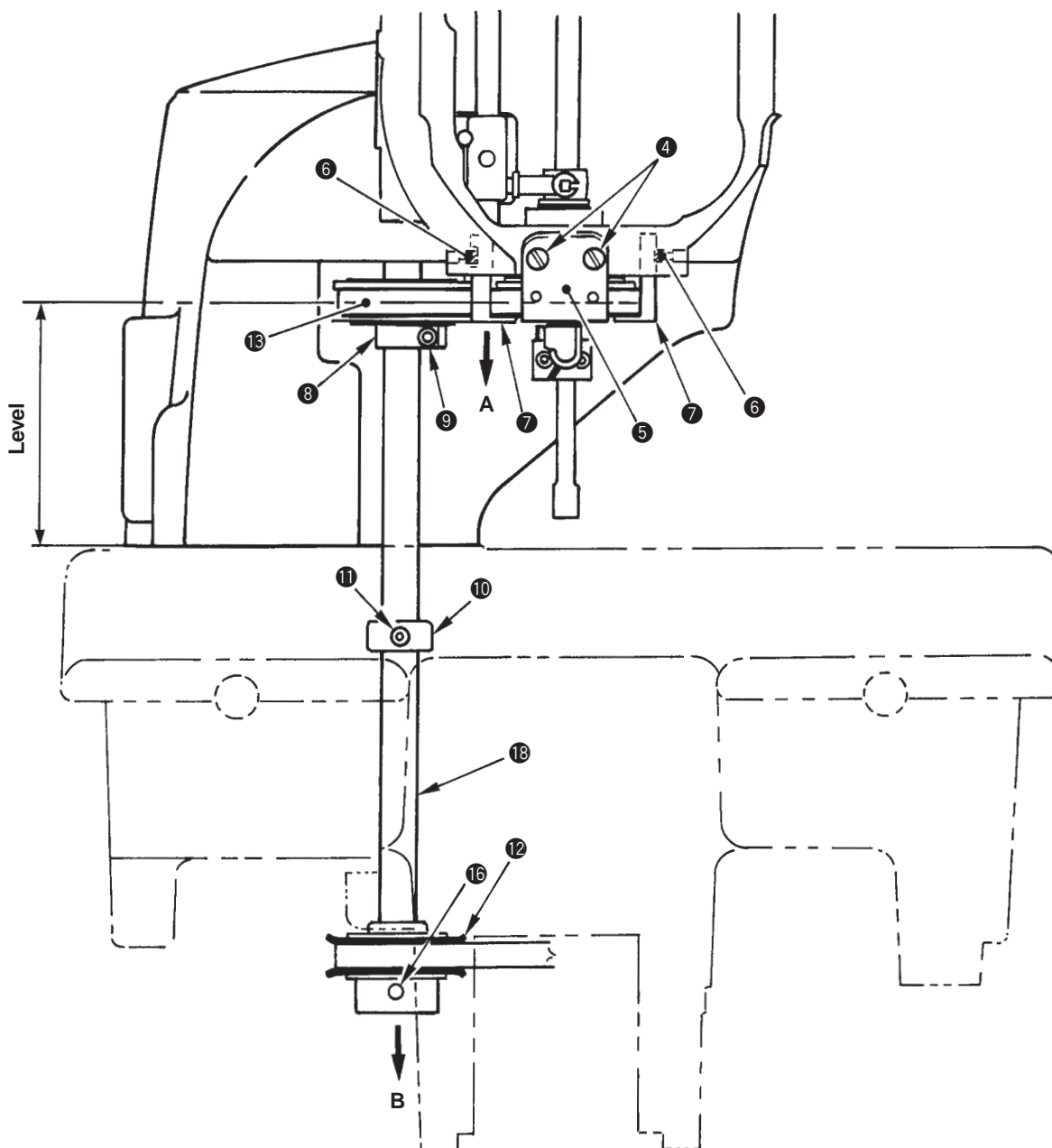

Caution in assembling

1. Assemble needle bar rotary timing belt 13, and assemble rotary pulley support A 5 and rotary pulley support B, left and right, 7.
At this time, remove the play of needle bar rotary pulley 17 so that rotary torque (load) of needle bar rotary pulley 17 does not become large.
2. Place needle bar rotary timing belt 13, pass rotary upper pulley 8 through rotary shaft, move rotary shaft upward (in the reverse direction of arrow mark B) and insert it in the machine arm section. When placing needle bar rotary timing belt 13, face to the front in advance the looper bracket, the needle bar and clamp screw 9 in rotary upper pulley 8.
3. Adjust setscrew 11 in thrust collar 10 and setscrew 13 in rotary lower pulley 12 to the flat work of rotary shaft 18, and tighten them respectively. At this time, remove the play of rotary shaft 18 such a way as holding the machine bed with thrust collar 10 and rotary lower pulley 12.
4. Determine the vertical position of rotary upper pulley 8 so that needle bar rotary timing belt 13 is level and temporarily tighten clamp screw 9.
5. Adjust the belt tension of the needle bar rotary timing belt according to "(27) Adjusting the tension of the needle bar rotary timing belt", and tighten setscrew 15.
6. Make sure of the position of the rotary sensor slit according to "(30) Adjusting the position of the looper bracket". When the position is changed, re-adjust the position.
7. Adjust the center of the needle according to "(1) Adjusting the center of the needle".

(Caution) When disassembling / assembling needle bar rotary timing belt 13 or needle bar components, the center of the needle changes. Be sure to check or re-adjust the center of the needle.

8. Make the rotary timing on the needle bar side correspond with that on the looper side according to "(29) Adjusting the position of the needle bar rotary pulley".
9. Perform the adjustment such as "(5) Timing between the needle and the looper, (6) Clearance between the needle and the looper, (8) Installation position of the spreaders and the timing to open/close the spreaders, etc."

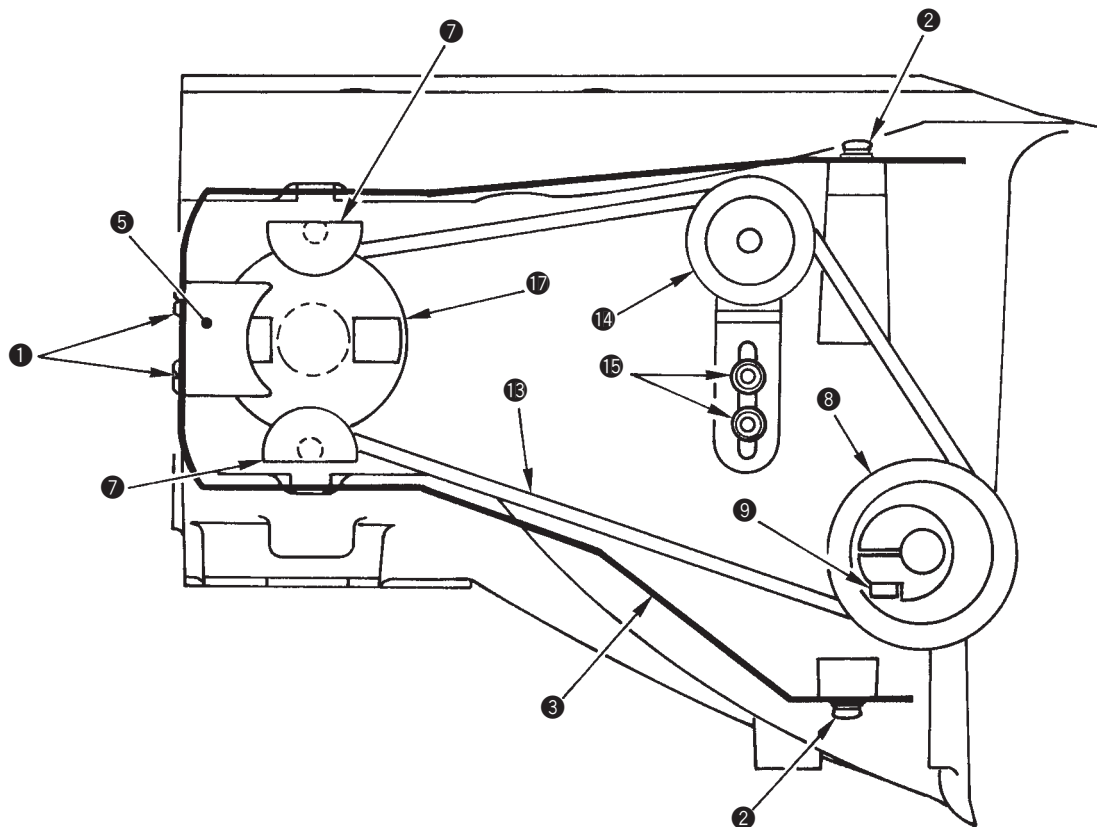

(8) Replacing the needle bar rotary lower timing belt

Procedures of disassembling/assembling

1. Remove the needle.
Then, pay attention to cords, oil wicks, etc., and check the state and procedure of wiring, piping before starting disassembling.
2. Raise the machine head, remove four setscrews ① and remove looper thread AT unit ②.
3. Remove four setscrews ③ and remove rotary motor unit ④.
The rotary sensor slit of rotary motor unit ③ is made of a thin plate. Be careful that the slit is not bent with looper rotary timing belt ⑤ or the like.
4. Remove setscrew ⑥ remove oil tank unit ⑦.
5. Loosen two setscrews ⑧ at boss section ⑫ of the machine bed and the two setscrews in thrust collar ⑮, and draw out fulcrum shaft ⑨. Loosen the setscrew in bracket ⑳ and remove spreader driving arm ⑬. (Oil wick may be kept connected.)
6. Loosen two setscrews ⑩ and the two setscrews in thrust collar ⑰, and draw out fulcrum shaft ⑪. Loosen the setscrew in bracket ㉓ and remove looper driving arm ⑭. (Oil wick may be kept connected.)
7. Remove looper rotary timing belt ⑤.

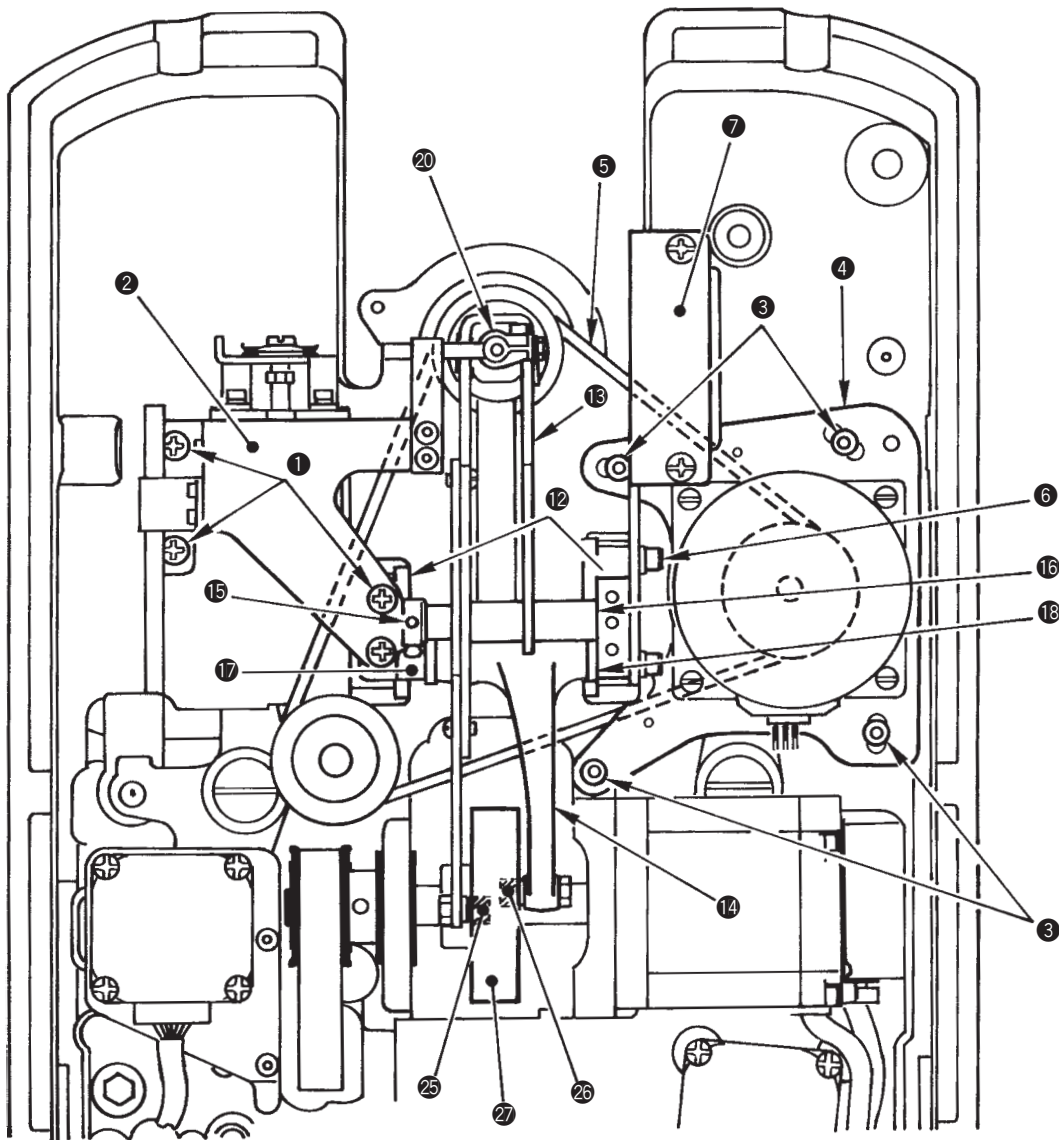

Caution in assembling

1. Assemble looper rotary timing belt ⑤ and assemble looper driving arm ⑭. When inserting or drawing out fulcrum shaft ⑩, make thrust washer ⑱ come in contact with boss section ⑫ of the machine bed and remove the play with thrust collar ⑰. Cam roller ⑳ enters looper cam section ㉓. When inserting the forked section of looper driving arm ⑭ into looper driving shaft ㉒, remove the play with thrust washer ㉔ and bracket ㉓. (Face the polished faces of thrust washers ㉑ and ㉒ to the sides of driving arms ⑭ and ⑬.)
2. Similarly, assemble spreader driving arm ⑬. Cam roller ㉕ enters looper cam ㉓.
3. Turn the looper bracket by hand and check the rotary torque of it. When the rotary load is large, loosen once bracket ㉒ and bracket ㉓, and remove again thrust (remove the play).
4. Assemble oil tank unit ⑦ and temporarily tighten rotary motor unit ④ while placing looper rotary timing belt ⑤.
At this time, face the looper bracket and the needle bar to the front respectively and adjust the rotary sensor slit of rotary motor unit ④ roughly on the sensor.
5. Adjust the tension of the belt according to “(28) Adjusting the tension of the looper rotary timing belt” and fix rotary motor unit ④.
6. Assemble looper thread AT unit ②.
7. Adjust the position of the rotary sensor slit according to “(30) Adjusting the position of the looper bracket”.
8. Check whether the center of the needle is proper according to “(1) Adjusting the center of the needle”. Re-adjust the center when it is improper.
9. Make the rotary timing on the needle bar side correspond with that on the looper side according to “(29) Adjusting the position of the needle bar rotary pulley”.
10. Perform the adjustment such as “(5) Timing between the needle and the looper, (6) Clearance between the needle and the looper, (8) Installation position of the spreaders and the timing to open/close the spreaders, etc.”.

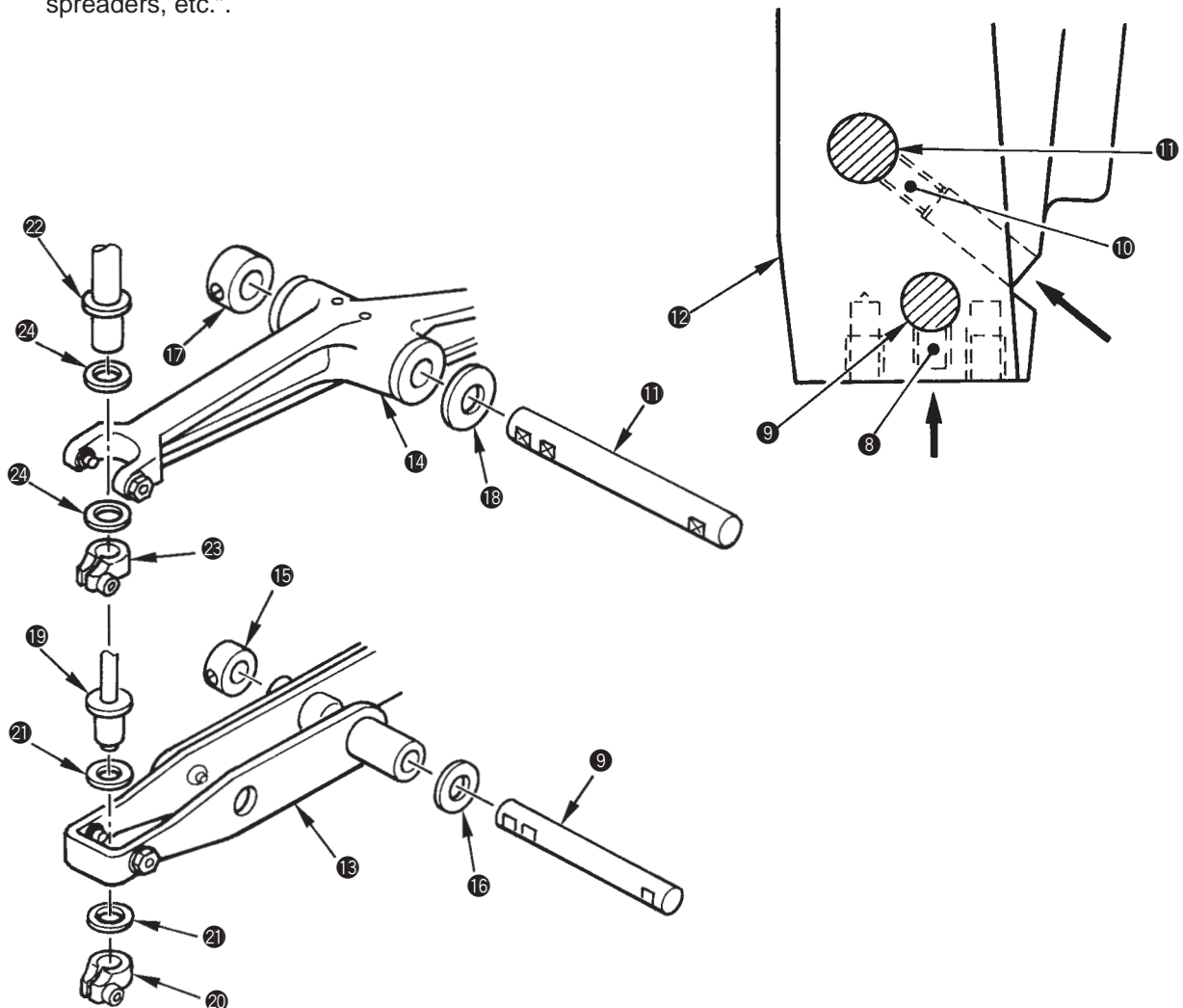

(9) Disassembling the marking light

Procedures of disassembling/assembling

1. Insert laser marking projector ① into marking light installing base ② and temporarily tighten it with laser marking projector setscrews ③.
2. Temporarily set marking light installing base ② to marking light installing plate ④ with marking light installing base setscrews ⑤ and marking light installing base washers ⑥.
3. Fix marking light installing plate ④ and marking light installing plate boss ⑦ in screw holes A and A' with marking light installing plate setscrews ⑧.
4. Fix cable ①-a of laser marking projector ① in screw hole B of the machine arm with cable clip ⑨ and cable clip setscrew ⑩.
5. Pass cable ①-a through the hole in the left rear of the machine table.

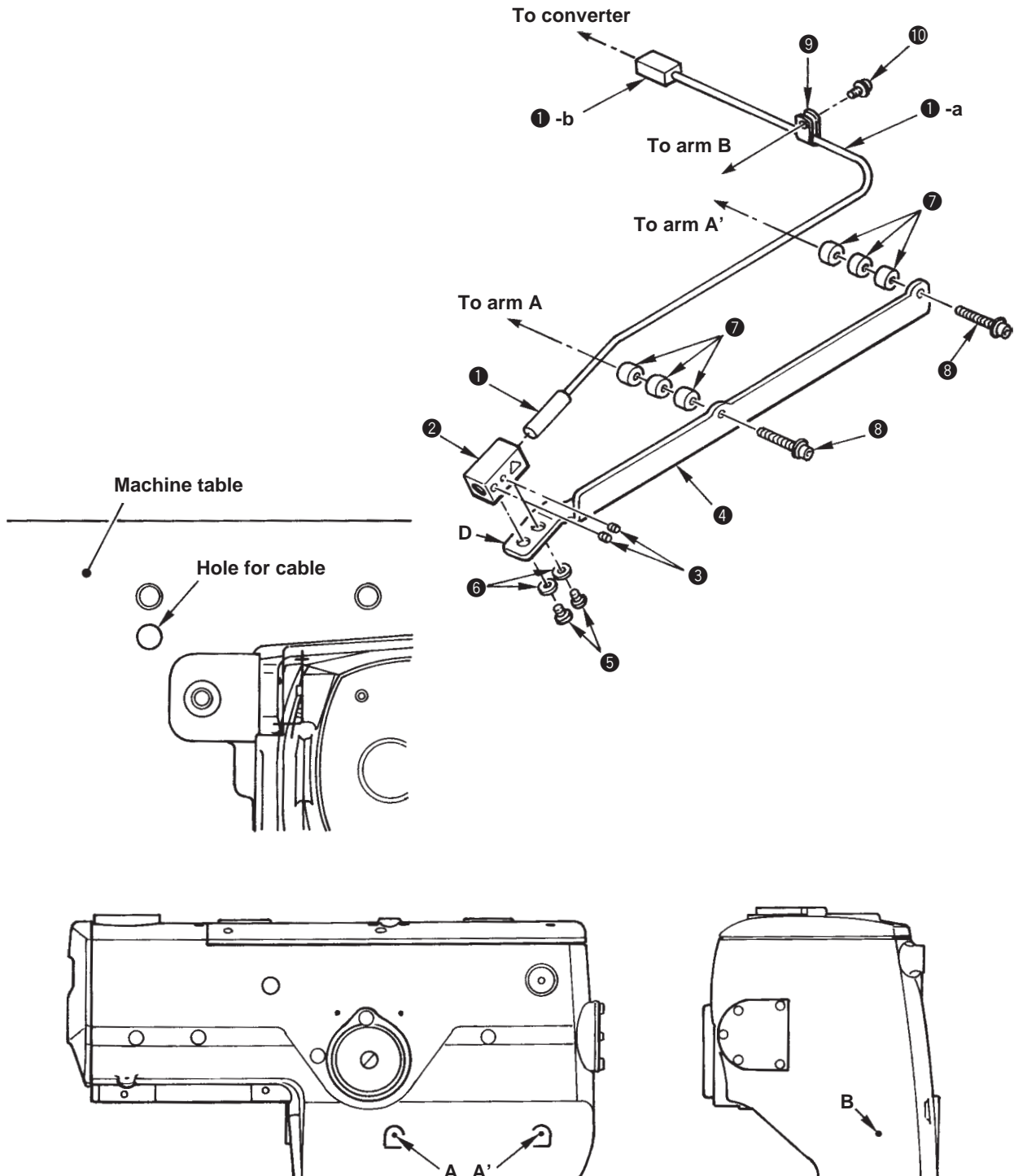

Caution in assembling

1. The marking light cannot be installed to RS and RD types.
2. Do not watch directly the beam of laser marking projector ①.
3. Adjust so that the top end of laser marking projector ① should protrude approximately 13.5 mm from marking light installing base ②.

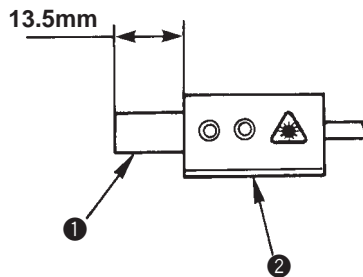

4. When attaching the marking light on the machine arm, set cable ①-a of laser marking projector ① to the underside of marking light installing plate boss ⑦ so that the cable is not caught in the machine arm.

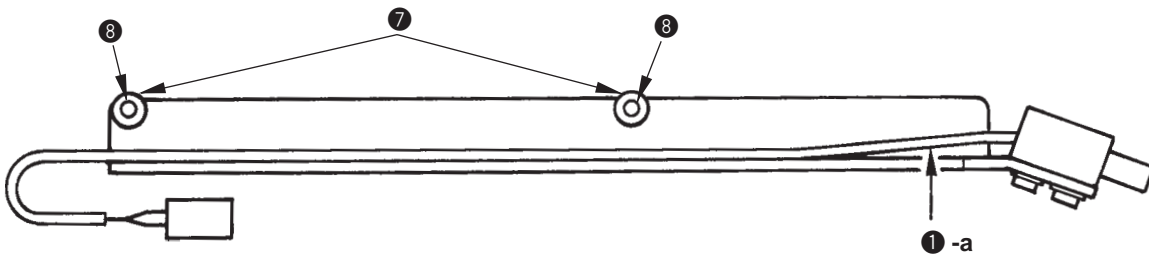

5. When attaching the marking light on the machine arm, if the center of section D of marking light installing plate ④ is moved approximately 7 mm to the right side as viewed from the face section, set marking light installing plate bosses ⑦ as shown figure.

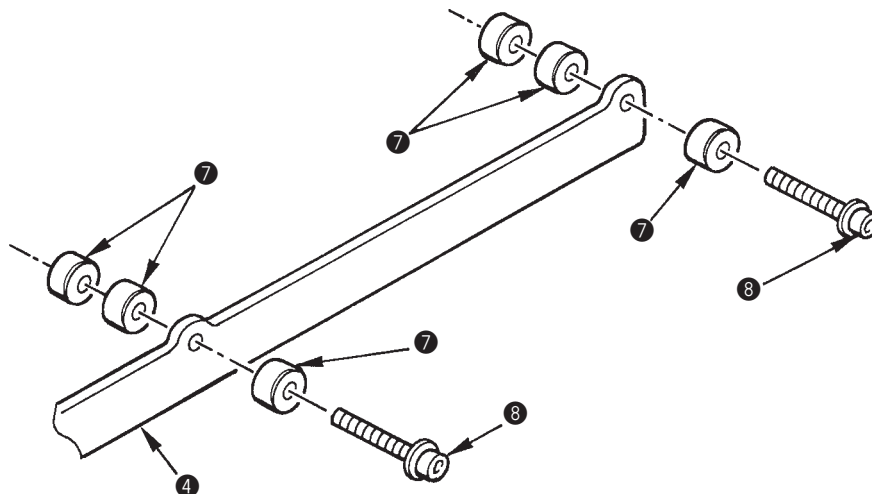

(9) Disassembling the marking light

Procedures of disassembling/assembling

1. Insert 24-6V converter ⑪ into converter installing plate ⑫ and fix it with 24-6V converter setscrews ⑬.
2. Fix converter installing plate ⑫ to an optional place to the bottom side of the machine table with converter installing plate setscrew ⑭.
3. Connect pin ⑪-a (White color) of 24-6V converter ⑪ to No. 40 of the solenoid valve cable connector (CN80) and pin ⑪-b (Black color) to No. 35 of the solenoid valve cable connector (CN80).
4. Connect connector ⑪-c of 24-6V converter ⑪ to connector ①-b of laser marking projector ①.
5. Bind the excess cables of laser marking projector ① and 24-6V converter ⑪ together with other cables using the clip band supplied with the machine.

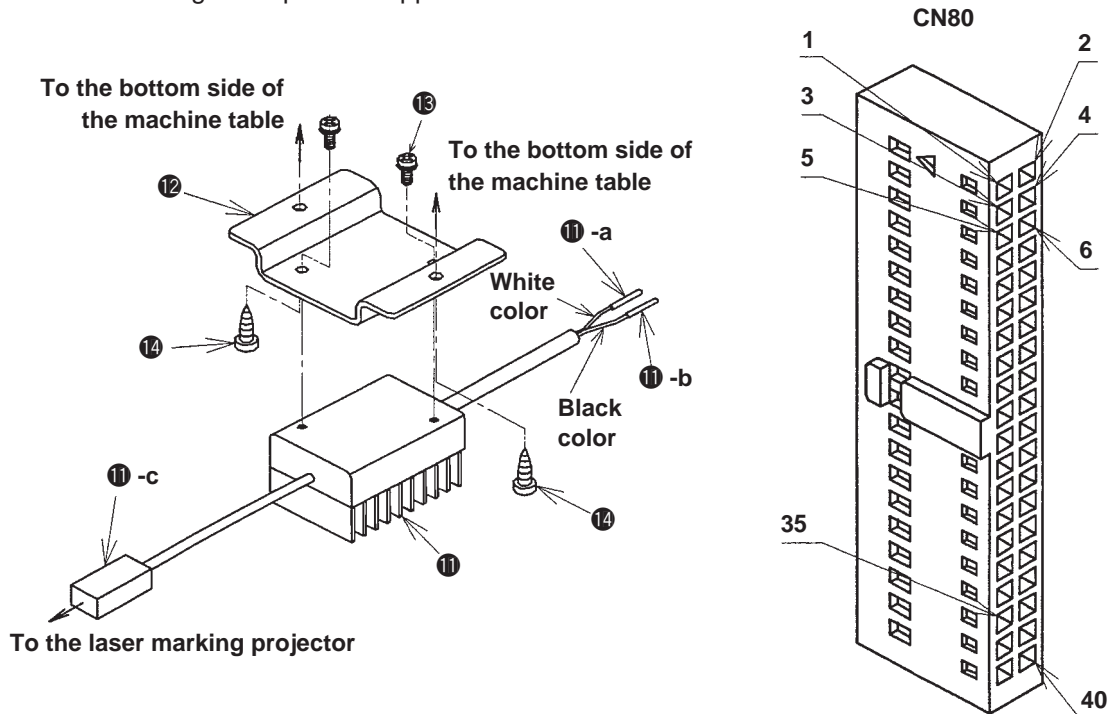

(10) Fine adjustment of the laser marking projector

Standard Adjustment

1) Adjusting the light axis of the laser marking projector

Adjust so that the laser beam coming out from the laser marking projector ① should be vertical to the top face of the machine bed.

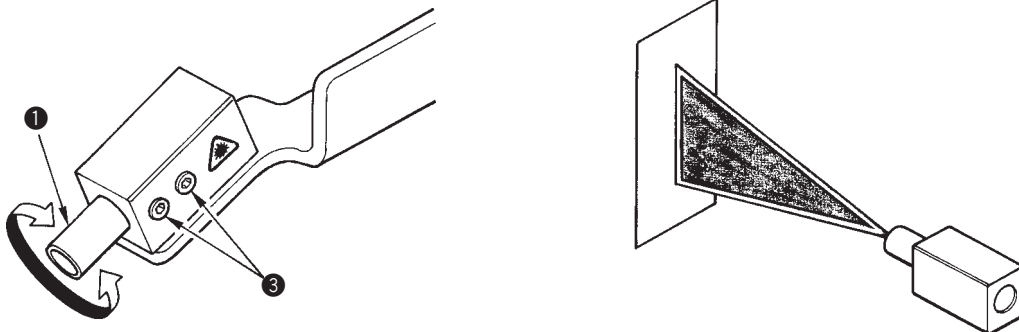

Caution in assembling

Adjustment Procedures	Results of Improper Adjustment
<ol style="list-style-type: none">1. Loosen two laser marking projector setscrews ③.2. Turn laser marking projector ① in the direction of arrow mark and adjust it so that the laser beam should be vertical to to the top fce of the machine bed.3. Tighten two laser marking projector setscrews ③ to fix the projector. <p>(Caution) Do not watch directly the laser beam of the laser marking projector ①.</p>	<ul style="list-style-type: none">○ When the light axis of laser beam is slipped : <ol style="list-style-type: none">1. Laser beam is lit slantwise to the sewing product.2. Laser beam cannot be adjusted to the center of needle.

Standard Adjustment

2) Adjusting the lateral direction of the laser marking projector

Adjust the marking light installing base ② so that the laser beam coming out from the laser marking projector lights on the center of needle.

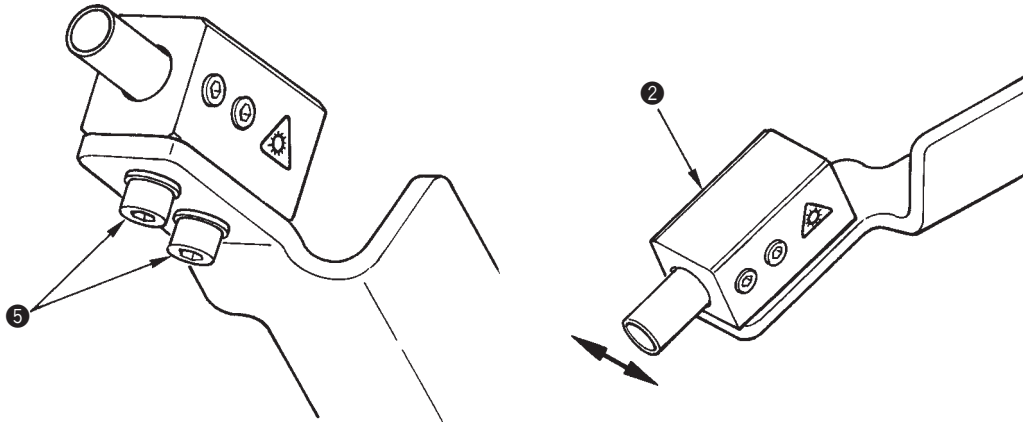

3) Adjusting the irradiating range of the laser beam

Adjust the position of the marking light installing plate ④ and the protruding amount of the laser marking projector ① so that the laser beam reaches the origin position being used.

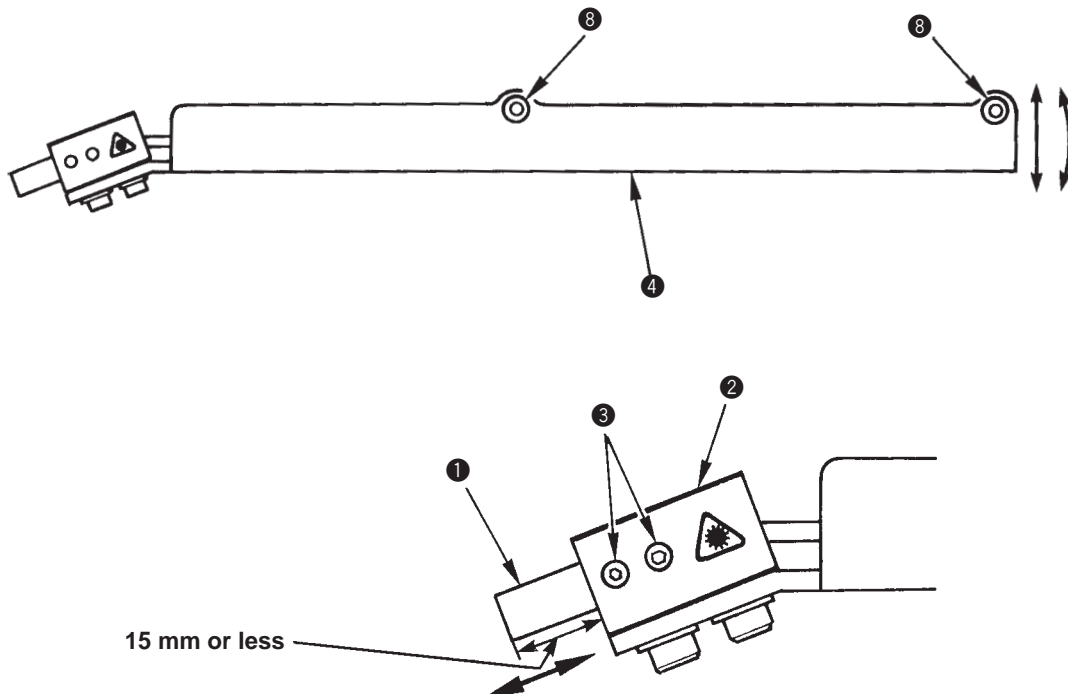

Adjustment Procedures	Results of Improper Adjustment
<ol style="list-style-type: none"> 1. Loosen two marking light installing base setscrews ⑤. 2. Move marking light installing base ② in the direction of arrow mark and adjust it so that the laser beam lights on the center of needle. 	<ul style="list-style-type: none"> ○ When the laser beam is laterally slipped : <ol style="list-style-type: none"> 1. Laser beam does not correspond with the sewing position.
<ol style="list-style-type: none"> 1. Loosen two marking light installing base setscrews ⑧. 2. Move marking light installing plate ④ up or down, or in the direction of rotation as the arrow marks and adjust it so that the laser beam reaches the origin position being used. 3. If the adjustment of the position of marking light installing plate ④ only is insufficient, loosen two laser marking projector setscrews ③, move laser marking projector ① in the direction of arrow mark and adjust it so that the laser beam can reach the origin position being used. <p>(Caution) Adjust the protruding amount of laser marking projector ① from the marking light installing base ② to 15 mm or less.</p>	

(11) Replacing the presser set

Procedures of disassembling/assembling

For the optional presser sets, three kinds of S, M, and L are prepared according to the sewing length. Replace ① to ④ as shown in the figure below which are included in the optional presser sets and change the position of knife unit ⑨, upper knife lower cover ⑪, knife installing plate ⑫ and knife cover ⑬.

1. Remove cloth cutting knife ⑥ to replace it.
2. Remove knife cover ⑬ with two setscrews ⑭.
3. Remove hinge screw ⑦ and two setscrews ⑧ on the bottom face of the presser plate. Then remove knife unit ⑨, upper knife lower cover ⑪ and knife installing plate ⑫.
4. Remove setscrews ⑮ once and replace presser feet ③ and ④. At this time, be sure to insert bending washer ⑮.
5. Remove setscrews ⑩ once and replace holding plates ① and ②.
(Setscrews ⑩ of left-hand side holding plate ② of type L are three pieces.)
6. Fix knife unit ⑨, upper knife lower cover ⑪ and knife installing plate ⑫ to the corresponding positions on the presser plate with two setscrews ⑧ and tighten hinge screw ⑦ in the corresponding position.
7. Fix knife cover ⑬ to the corresponding position according to the presser set size with two setscrews ⑭.

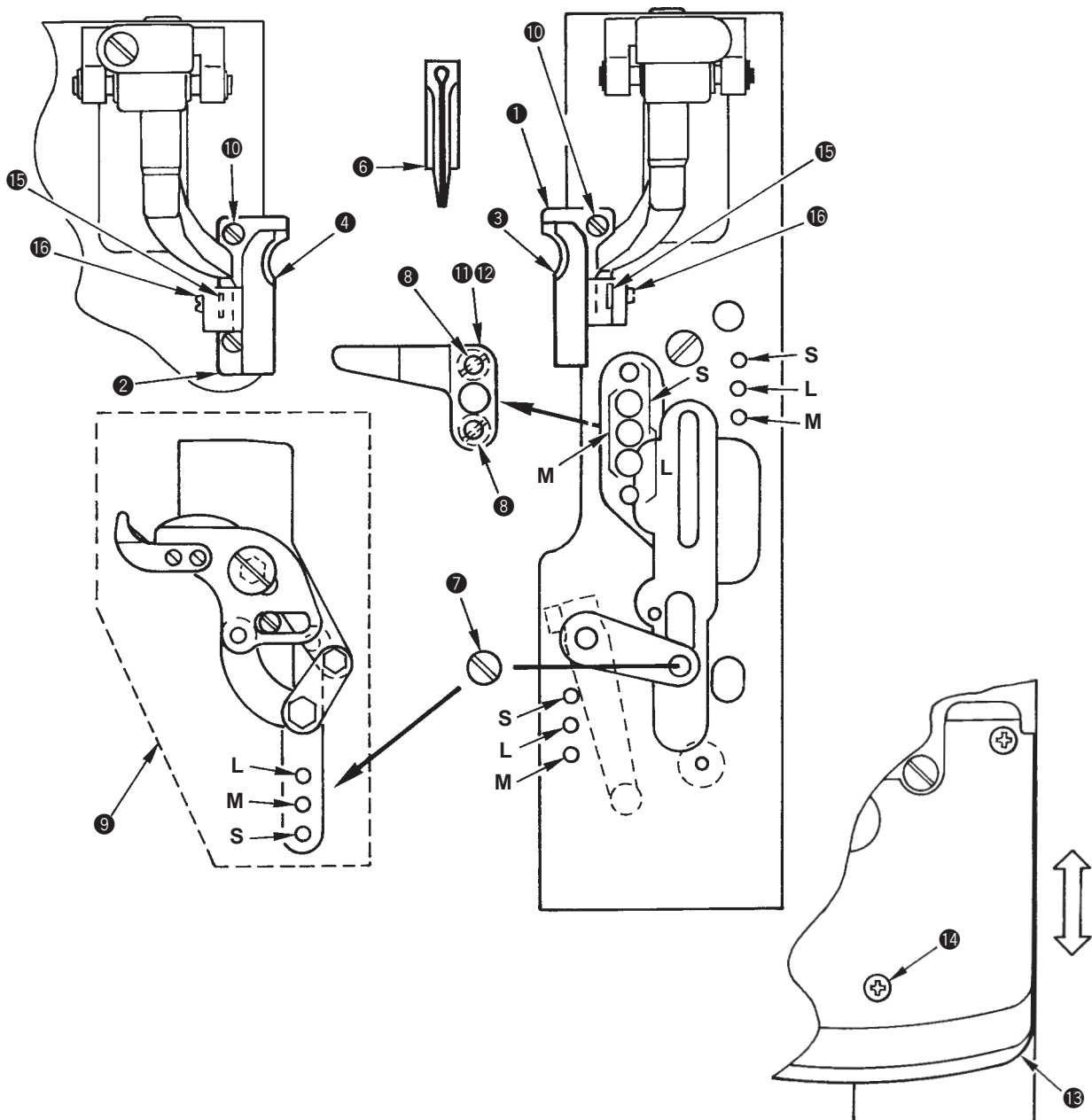

Caution in assembling

1. Cloth cutting knife ⑥ which can be used is up to the same length as that supplied with each presser set.

In addition, sewing size (cut length + taper bar length) is as described below :

- 1) Presser set S : 16 to 24 mm (26 mm)
- 2) Presser set M : 24 to 32 mm (34 mm)
- 3) Presser set L : 32 to 40 mm (42 mm)

* Sewing length may be limited by the data compensation in terms of sewing length.

(Example) In case compensation of number of stitches at sewing end (No. 9) is +1 stitch, the maximum sewing length is limited shorter as many as 1 stitch.

* In case ROM is after 010A, sewing of taper bar and without bar only can be performed up to the length in parentheses ().

* In case a cloth cutting knife longer than the cloth cutting knife size which can be used is used, the knife interferes with upper knife lower cover ⑪ at the time of thread trimming.

Replace the cloth cutting knife with the one which is in the range of size, or cut the cloth cutting knife.

2. When attaching upper knife lower cover ⑪, assemble it in the proper position referring to “(15) Adjusting the short thread trimming”.
3. Fitting screw ⑯, bending washer ⑮ and setscrew ⑩ are included in the presser set as spare parts.
4. After replacing the presser set, perform the change of DIP switch according to the sewing size of the corresponding presser set. If the sewing size outside the range of the presser set is sewn with the wrong setting, knife unit ⑨ or upper knife lower cover ⑪ interferes with needle, or thread trimming failure will be caused.

(12) Removing procedure of the looper thread trimming unit (When sewing beyond 38 mm)

Procedures of disassembling/assembling

For the long thread trimming (S/R) type, when sewing beyond the sewing length of 38 mm, remove the knife cover and looper thread trimming unit (looper thread trimming cannot be used.).

1. Remove the knife cover.
2. Loosen clamp screw ② and draw driving arm ① in the direction B. Moving knife unit ⑤, return spring ④ and spring holder ③ are removed.
3. Remove two flat head screws ⑦ on the bottom face of presser plate ⑧ and remove the counter knife unit ⑥.
4. Remove hinge screw ⑩ on top face of presser plate ⑧ and remove rubber stopper ⑨.
5. Remove the dirt such as grease or the like on the presser plate and cover the concave section and hole ⑪ with tape or the like.
6. After removing the looper thread trimming unit, change memory switch No. 22 from "1" to "0" to set the sewing length (cut length + taper bar length) to the length beyond 38 mm and sewing can be performed.

(Caution) It is possible to set the sewing length up to 50 mm. However, the section where presser foot or holding plate cannot press is apt to make material flop or slip, and stitch skipping, uneven stitch or slippage of shape may be caused. (There is no setting of presser foot or holding plate beyond 38 mm.)

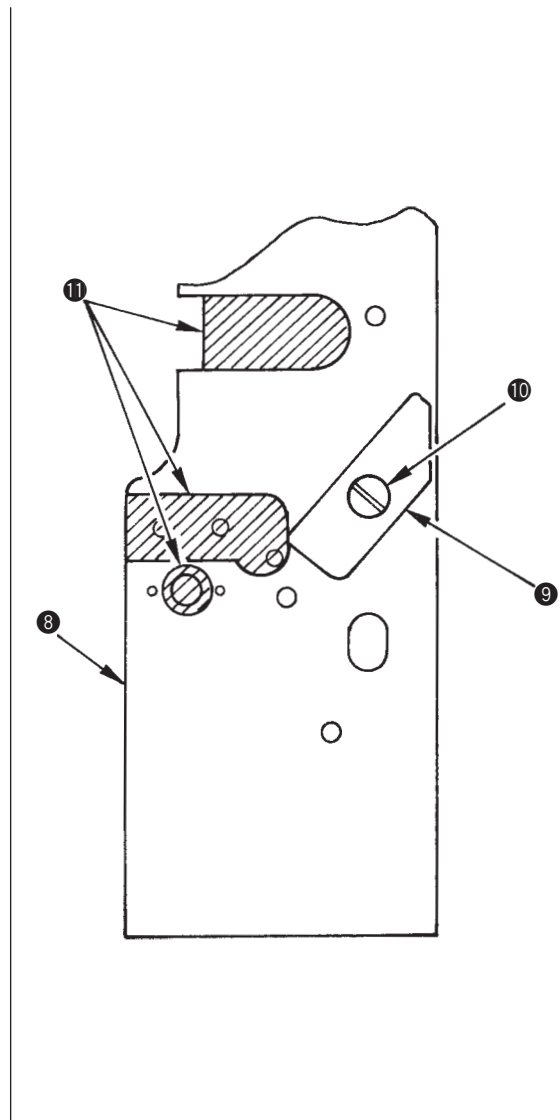
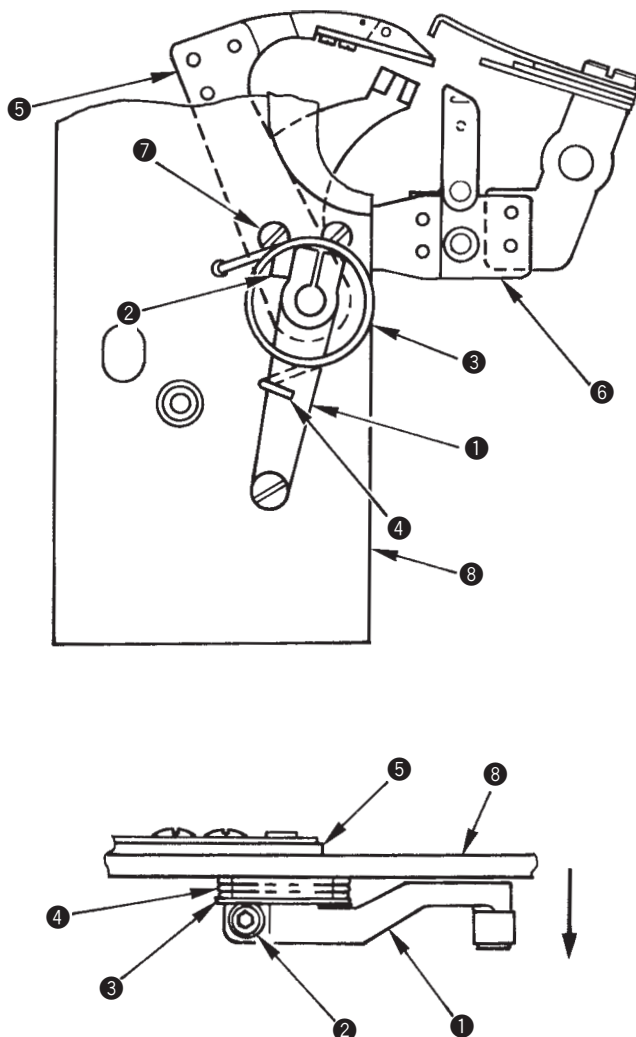

Adjustment Procedures	Results of Improper Adjustment
<p>1. When returning the looper thread trimming unit, apply an adequate amount of grease to the sliding section of the shaft, spring, etc. Perform the respective adjustments referring to the items of the adjustment related to the looper thread trimming.</p> <p>2. After attaching the looper thread trimming unit and knife cover, immediately change memory switch No. 22 from "0" to "1". Error will occur when the pattern is beyond sewing length (cut length + taper bar length) of 38 mm.</p> <p>(Caution) If memory switch No. 22 is held as "0", the pattern which is beyond sewing length of 38 mm does not become an error. If the pattern beyond 38 mm is sewn by mistake when attaching the looper thread trimming unit and the knife cover, it is very dangerous since needle breakage or component breakgs will be caused. Never perform pattern sewing beyond 38 mm (or idle running) when attaching the looper thread trimming unit and the knife cover.</p>	

6. SETTING PROCEDURE OF THE SEWING DATA

The standard patterns of pattern Nos. 90 to 99 can change the sewing speed and the thread tension, however, cannot change the sewing shape. When changing the shape, it is necessary to copy the shape to another pattern No.

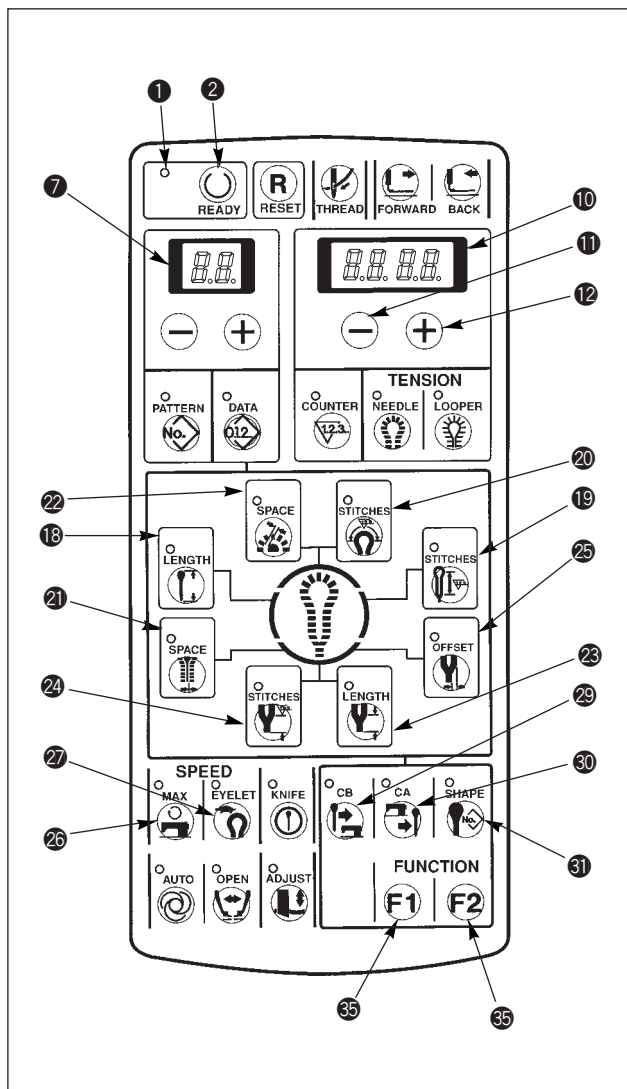

- 1) Confirm that sewing LED ❶ has gone out.
When it lights up, press [READY ❷] key ❷ to make it go out.
- 2) Display the pattern No. you desire to change the data .
- 3) Press the respective setting keys of the parts desired to be changed and display the data.
 - ❸ [SHAPE ❸] key
 - ❹ [LENGTH ❹] key
 - ❺ [CB ❺] key
 - ❻ [CA ❻] key
 - ❼ [STITCHES ❼] key
 - ❽ [STITCHES ❽] key
 - ❾ [SPACE ❾] key
 - ❿ [SPACE ❿] key
 - ⓫ [LENGTH ⓫] key
 - ⓬ [STITCHES ⓬] key
 - ⓭ [OFFSET ⓭] key
 - ⓮ [MAX ⓮] key
 - ⓯ [EYELET ⓯] key
 - ⓰ [FUNCTION F1 ❶❶] key
 - ⓱ [FUNCTION F2 ❷❷] key
- 4) Press [RIGHT +] key ❶❶ or [RIGHT -] key ❶❶ to set the respective data.
- 5) Press [READY ❷] key ❷ to light up sewing LED ❶ and the data are stored in memory.
 - When changing the pattern No. without pressing [READY ❷] key ❷ or turning OFF the power, the data are not stored in memory.
- 6) When the memory switch No. 20 is set to “1”, change of data setting in the above step 4) can be prohibited. (See the item “7. Memory switch”.)

(1) Sewing data setting item

(In case of the machine with multicutting device, refer to the item "15. MULTICUTTING DEVICE".)

Data No.	Setting itm	Setting range	Description
1	Knife No.	0 : Decorative, 1 to 6 : Eyelet 10 : Decorative, 11 to 16 : Eyelet	Shape of knife 0 to 6 ... Standard, 10 to 16 ... Plural times dropping Multicutting type
* 2	Cut length	Long thread trimming : 10 to 38 mm (1 mm) (Without looper thread trimming : 10 to 50 mm) Short thread trimming : 16 to 26 mm (1 mm) Short thread trimming M : 24 to 34 mm (1 mm) Short thread trimming L : 32 to 42 mm (1 mm) Short thread trimming without gimp : 10 to 34 mm (1 mm) T type	(When setting straight bar/round bar for short thread trimming, max. length becomes shorter by -2 mm.)
3	Cut-before/cut-after knife	0 : Without knife, 1 : Cut-before knife, 2 : Cut-after knife	Operation changeover of without knife/cut-before knife/ cut-after knife
4	Number of stitches of parallel	3 to 100 stitches	Number of stitches of parallel section + bottom of eyelet (Pitch 0.5 to 4 mm)
5	Number of stitches of eyelet	4 to 20 stitches	Number of stitches of top eyelet (needle bar turning section)
* 6	Cut space	-1.2 to 1.2 mm (0.1 mm unit)	Clearance of knife of parallel section
* 7	Eyelet space	-1.2 to 1.2 mm (0.1 mm unit)	Clearance of knife of eyelet section
* 8	Lengthwise compensation of knife position	-0.7 to 0.7 mm (0.1 mm unit)	Lengthwise compensation of whole needle entry position
9	Compensation of number of stitches at sewing end	-1 to 6 stitches	Number of stitches to increase length at sewing end
* 10	Compensation of turning	-14 to 14 (1.125° unit)	Turning compensation of parallel section + bottom of eyelet section
* 11	Compensation of turning at parallel section	-14 to 14 (1.125° unit)	Turning compensation of parallel section and eyelet section
* 13	Crosswise compensation of eyelet	-0.6 to 0.6 mm (0.1 mm unit)	Crosswise compensation of bottom of eyelet Same shape as that of top eyelet (needle bar turning section)
* 14	Lengthwise compensation of eyelet	-0.2 to 0.6 mm (0.1 mm unit)	Lengthwise compensation of top of eyelet
15	Lengthwise compensation of left eyelet	-0.2 to 0.6 mm (0.1 mm unit)	Lengthwise compensation of left eyelet
* 16	Lengthwise compensation of left parallel	-0.6 to 0.6 mm (0.1 mm unit)	Compensation of length of left parallel section
* 17	Compensation of stitch bite width of right bottom of eyelet	-0.1+W to 1.0+W (0.1 mm unit)	Compensation of stitch bite width of right bottom of eyelet (W = Stitch bite width of memory switch)
* 18	Compensation of stitch bite width of left bottom of eyelet	-0.1+W to 1.0+W (0.1 mm unit)	Compensation of stitch bite width of left bottom of eyelet (W = Stitch bite width of memory switch)
* 19	Compensation of stitch bite width	-0.1+W to 1.0+W (0.1 mm unit)	Compensation of stitch bite width (W = Stitch bite width of memory switch)
* 20	Length of taper bar	0.3 to 15 mm (1 mm unit)	Length of taper bar
21	Number of stitches of taper bar	2 to 20 stitches	Number of stitches of taper bar (Pitch 0.5 to 2.0 mm)
* 22	Taper bar offset	0.5 to 2.0 mm (0.1 mm unit)	Overlapping amount of left/right taper bars
23	Number of stitches of taper bar at parallel section	2 to 4 stitches	Number of stitches from taper bar to parallel section
24	Compensation of number of stitches of right taper bar	-20 to 0 stitch	Number of stitches of compensation of right taper bar
25	Shape of straight bar	0 or 1 to 96	Shape of straight bar
26	Number of stitches of round bar	4 to 20 stitches	Number of stitches of round bar
* 27	Compensation of left knife space of parallel section	-2.4 to 2.4 mm (0.1 mm unit)	Clearance between left parallel section and knife (= Max. of No. 6 + No. 27 is ±1.2 mm.)
28	Knife holder No.	0 to 9	Specifying knife adjustment value 0 to 9
29			
30			
31			
32			
33			
34			
* 35	Sewing speed	400 to 2,200 rpm (100 rpm unit)	Max. sewing speed
* 36	Reduced speed of eyelet	-600 to 0 rpm (100 rpm unit)	Reduced speed in terms of sewing speed of eyelet
37	Soft-start	0 to 6 needle entries	Number of stitches of soft-start at sewing start
38	Number of stitches of the sewing start	0 to 3	Number of stitches at sewing start Needle/looper thread tension
39	Number of stitches of the sewing end	0 to 3	Number of stitches at sewing end Needle/looper thread tension

* Numerical value in () parentheses of the setting range is the unit of set value.

Data No.	Setting itm	Setting range	Description
40	Needle thread tension	0 to 180	Needle thread tension value (Standard of individual needle thread tension)
41	Compensation of needle thread tension at right parallel section	-180 to 180	Compensation value of needle thread tension at right side of parallel section (Difference in terms of No=40)
42	Compensation of needle thread tension at left parallel section	-180 to 180	Compensation value of needle thread tension at left side of parallel section (Difference in terms of No=40)
43	Compensation of needle thread tension of eyelet	-180 to 180	Compensation value of needle thread tension at top of eyelet (Difference in terms of No=40)
44	Compensation of needle thread tension at right bottom of eyelet	-180 to 180	Compensation value of needle thread tension at right side of bottom of eyelet (Difference in terms of No=40)
45	Compensation of needle thread tension at left bottom of eyelet	-180 to 180	Compensation value of needle thread tension at left side of bottom of eyelet (Difference in terms of No=40)
46	Compensation of needle thread tension at right taper bar	-180 to 180	Compensation value of needle thread tension at right side of taper bar (Difference in terms of No=40)
47	Compensation of needle thread tension at left taper bar	-180 to 180	Compensation value of needle thread tension at left side of taper bar (Difference in terms of No=40)
48	Compensation of needle thread tension at straight bar	-180 to 180	Compensation value of needle thread tension at straight bar (Difference in terms of No=40)
49	Compensation of needle thread tension at right round bar	-180 to 180	Compensation value of needle thread tension at right side of round bar (Difference in terms of No=40)
50	Compensation of needle thread tension at left round bar	-180 to 180	Compensation value of needle thread tension at left side of round bar (Difference in terms of No=40)
51	Compensation of needle thread tension at sewing start	-180 to 180	Compensation value of needle thread tension at sewing start (Difference in terms of No=40)
52	Compensation of needle thread tension at sewing end	-180 to 180	Compensation value of needle thread tension at sewing end (Difference in terms of No=40)
53	Compensation of needle thread tension at the time of thread trimming	-180 to 180	Compensation value of needle thread tension at the time of thread trimming of the sewing machine (Difference in terms of memory switch 7)
54	Compensation of needle thread tension at the time of stop	-180 to 180	Compensation value of needle thread tension at the time of stop of the sewing machine (Difference in terms of memory switch 9)
55			
56			
57			
58			
59			
60	Looper thread tension	0 to 180	Looper thread tension value (Standard of individual looper thread tension)
61	Compensation of looper thread tension at right parallel section	-180 to 180	Compensation value of looper thread tension at right side of parallel section (Difference in terms of No=60)
62	Compensation of looper thread tension at left parallel section	-180 to 180	Compensation value of looper thread tension at left side of parallel section (Difference in terms of No=60)
63	Compensation of looper thread tension of eyelet	-180 to 180	Compensation value of looper thread tension at top of eyelet (Difference in terms of No=60)
64	Compensation of looper thread tension at right bottom of eyelet	-180 to 180	Compensation value of looper thread tension at right side of bottom of eyelet (Difference in terms of No=60)
65	Compensation of looper thread tension at left bottom of eyelet	-180 to 180	Compensation value of looper thread tension at left side of bottom of eyelet (Difference in terms of No=60)
66	Compensation of looper thread tension at right taper bar	-180 to 180	Compensation value of looper thread tension at right side of taper bar (Difference in terms of No=60)
67	Compensation of looper thread tension at left taper bar	-180 to 180	Compensation value of looper thread tension at left side of taper bar (Difference in terms of No=60)
68	Compensation of looper thread tension at straight bar	-180 to 180	Compensation value of looper thread tension at straight bar (Difference in terms of No=60)
69	Compensation of looper thread tension at right round bar	-180 to 180	Compensation value of looper thread tension at right side of round bar (Difference in terms of No=60)
70	Compensation of looper thread tension at left round bar	-180 to 180	Compensation value of looper thread tension at left side of round bar (Difference in terms of No=60)
71	Compensation of looper thread tension at sewing start	-180 to 180	Compensation value of looper thread tension at sewing start (Difference in terms of No=60)
72	Compensation of looper thread tension at sewing end	-180 to 180	Compensation value of looper thread tension at sewing end (Difference in terms of No=60)
73	Compensation of looper thread tension at the time of thread trimming	-180 to 180	Compensation value of looper thread tension at the time of thread trimming of the sewing machine (Difference in terms of memory switch 8)
74	Compensation of looper thread tension at the time of stop	-180 to 180	Compensation value of looper thread tension at the time of stop of the sewing machine (Difference in terms of memory switch 10)
75			
76			
77			
78			
78			
79			
80	Writing No.	1 to 99 (0 to 99 by memory switch)	Writing pattern No. (At the time of No. = "0", data is deleted.)
81	Cut length compensation	0 to cut length - knife length	Compensation value of cloth cut length in terms of No. 2 Cut length at the time of plural times motion of knife
82	Plural times selection	0 : Knife holder without step eyelet 1 : Decorative buttonhole 2 : Knife holder with step eyelet 3 : Knife holder with step eyelet only	Method of selecting cloth cutting at the time of plural times motion of knife
83	Decorative buttonhole offset	0 to cut length - knife length	Offset position of cloth cutting when selecting decorative buttonhole at the time of plural times motion of knife

Diagram of each set value (State of sewing, i.e, state that the product is observed from the wrong side.)

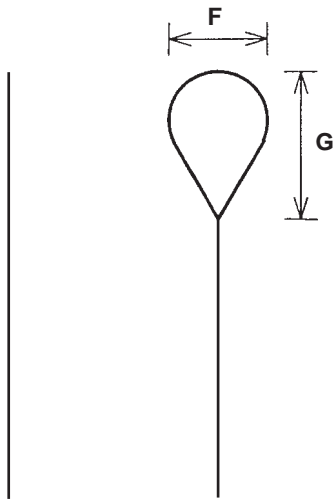

Kind of knife		F x G
0	10	Decorative buttonhole
1	11	2.1 x 3.2
2	12	2.5 x 3.8
3	13	2.9 x 4.4
4	14	3.0 x 4.6
5	15	3.2 x 5.4
6	16	2.7 x 5.1

Decorative buttonhole Eyelet

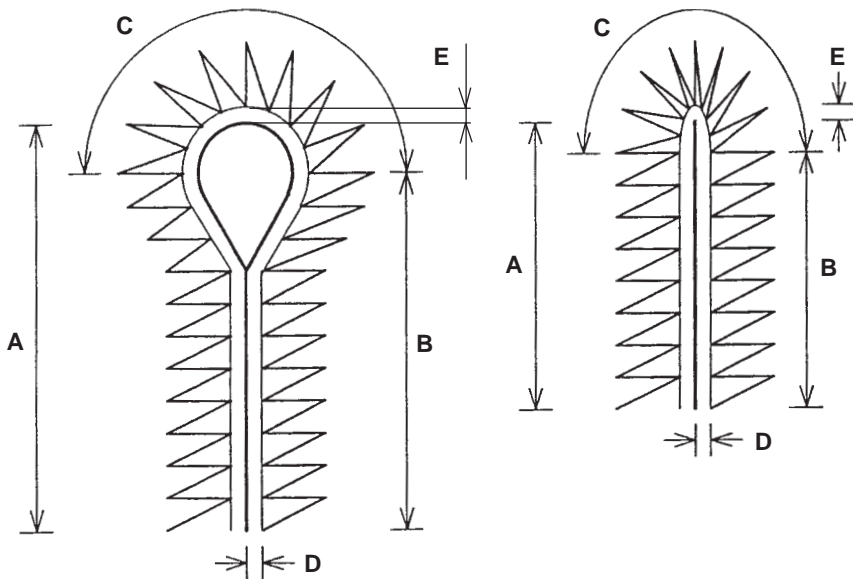

A	Cut length
B	Number of stitches of parallel
C	Number of stitches of eyelet
D	Knife space
E	Knife space of eyelet

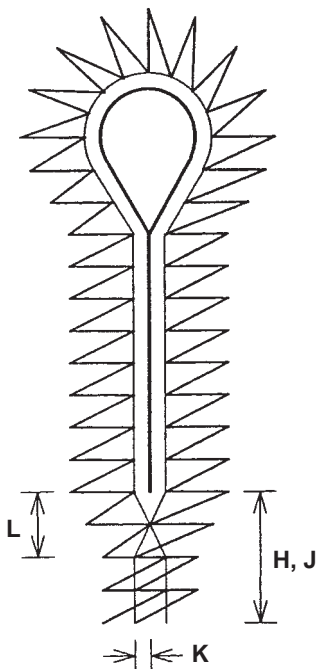

H	Length of taper bar
J	Number of stitches of taper bar
K	Taper bar offset
L	Number of stitches of slant taper bar

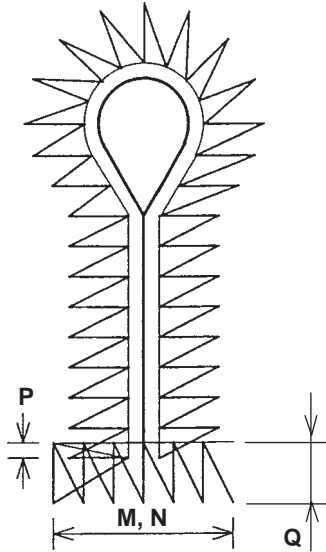

M	Length of straight bsr
N	Number of stitches of straight bar
P	Overlapping width of straight bar
Q	Compensation of stitch bite width of straight bar

Select the combination Nos. described in the table below for the shape of the straight bar.

Data of the straight bar

No.	Length	Number of stitches	Overlapping amount	Compensation of width
1	3.0	4	1.0	0
2	4.0	5	1.0	0
3	5.0	6	1.0	0
4	6.0	7	1.0	0
5	7.0	8	1.0	-0.5
6	8.0	9	1.0	-1.0
7	3.0	5	1.0	0
8	4.0	6	1.0	0
9	5.0	7	1.0	0
10	6.0	9	1.0	0
11	7.0	10	1.0	-0.5
12	8.0	11	1.0	-1.0
13	3.0	6	1.0	0
14	4.0	8	1.0	0
15	5.0	9	1.0	0
16	6.0	11	1.0	0
17	7.0	13	1.0	-0.5
18	8.0	14	1.0	-1.0
19	3.0	4	1.5	0
20	4.0	5	1.5	0
21	5.0	6	1.5	0
22	6.0	7	1.5	0
23	7.0	8	1.5	-0.5
24	8.0	9	1.5	-1.0
25	3.0	5	1.5	0
26	4.0	6	1.5	0
27	5.0	7	1.5	0
28	6.0	9	1.5	0
29	7.0	10	1.5	-0.5
30	8.0	11	1.5	-1.0
31	3.0	6	1.5	0
32	4.0	8	1.5	0
33	5.0	9	1.5	0
34	6.0	11	1.5	0
35	7.0	13	1.5	-0.5
36	8.0	14	1.5	-1.0
37	3.0	4	1.0	-0.5
38	4.0	5	1.0	-0.5
39	5.0	6	1.0	-0.5
40	6.0	7	1.0	-0.5
41	7.0	8	1.0	-1.0
42	3.0	5	1.0	-0.5
43	4.0	6	1.0	-0.5
44	5.0	7	1.0	-0.5
45	6.0	9	1.0	-0.5

No.	Length	Number of stitches	Overlapping amount	Compensation of width
46	7.0	10	1.0	-1.0
47	3.0	6	1.0	-0.5
48	4.0	8	1.0	-0.5
49	5.0	9	1.0	-0.5
50	6.0	11	1.0	-0.5
51	7.0	13	1.0	-1.0
52	3.0	4	1.5	-0.5
53	4.0	5	1.5	-0.5
54	5.0	6	1.5	-0.5
55	6.0	7	1.5	-0.5
56	7.0	8	1.5	-1.0
57	3.0	5	1.5	-0.5
58	4.0	6	1.5	-0.5
59	5.0	7	1.5	-0.5
60	6.0	9	1.5	-0.5
61	7.0	10	1.5	-1.0
62	3.0	6	1.5	-0.5
63	4.0	8	1.5	-0.5
64	5.0	9	1.5	-0.5
65	6.0	11	1.5	-0.5
66	7.0	13	1.5	-1.0
67	3.0	4	1.0	-1.0
68	4.0	5	1.0	-1.0
69	5.0	6	1.0	-1.0
70	6.0	7	1.0	-1.0
71	3.0	5	1.0	-1.0
72	4.0	6	1.0	-1.0
73	5.0	7	1.0	-1.0
74	6.0	9	1.0	-1.0
75	3.0	6	1.0	-1.0
76	4.0	8	1.0	-1.0
77	5.0	9	1.0	-1.0
78	6.0	11	1.0	-1.0
79	3.0	4	1.5	-1.0
80	4.0	5	1.5	-1.0
81	5.0	6	1.5	-1.0
82	6.0	7	1.5	-1.0
83	3.0	5	1.5	-1.0
84	4.0	6	1.5	-1.0
85	5.0	7	1.5	-1.0
86	6.0	9	1.5	-1.0
87	3.0	6	1.5	-1.0
88	4.0	8	1.5	-1.0
89	5.0	9	1.5	-1.0
90	6.0	11	1.5	-1.0

1) Compensation of the data

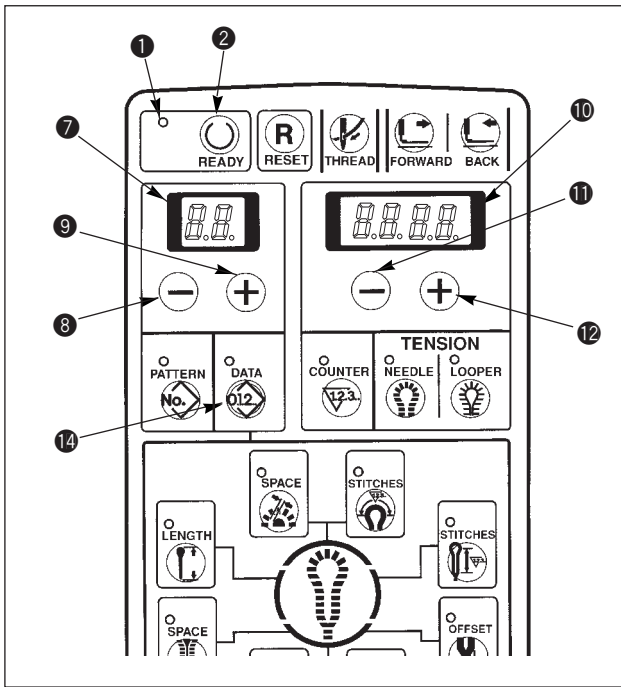

- 1) Confirm that sewing LED ① has gone out.
When the LED lights up, press [READY ②] key ② to make it go out.
- 2) Display the pattern No. desired to be changed.
- 3) Press [DATA ⑭] key ⑭ to display the data.
- 4) Press [LEFT +] key ⑨ or [LEFT -] key ⑧ to display the data No. of the part desired to be changed.
- 5) Press [RIGHT +] key ⑫ or [RIGHT -] key ⑪ and set the respective data.
- 6) Press [READY ②] key ② to light up sewing LED ① and the data are stored in memory.
When changing the pattern No. without pressing [READY ②] key ② or turning OFF the power, the data are not stored in memory. It is necessary to set again the data.
- 7) When the memory switch No. 20 is equal to "1", change of setting the data in step 5) can be prohibited.
 - Data No. is displayed in 2-digit LED ⑦ and set value in 4-digit LED ⑩.
 - For the details, refer to the item 9. Compensation of the data in the Instruction Manual.

① Compensation table

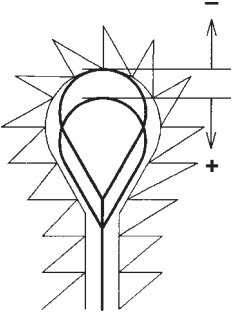
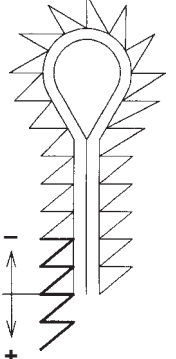
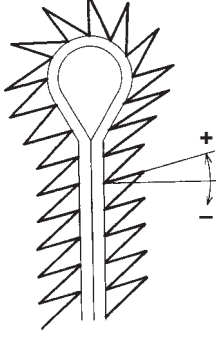
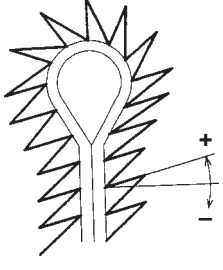
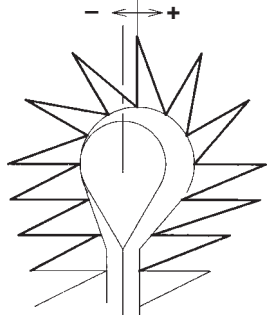
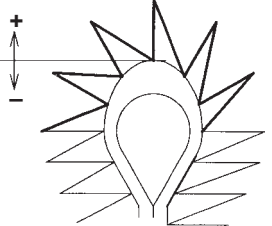
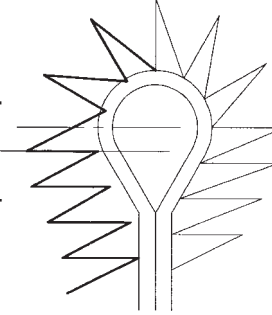
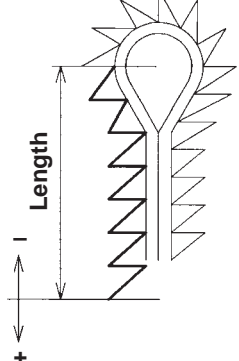
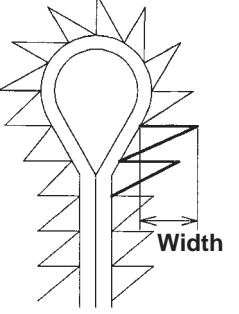
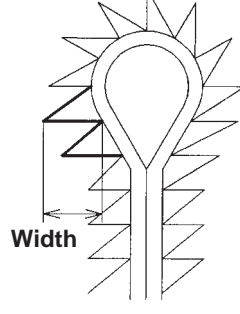
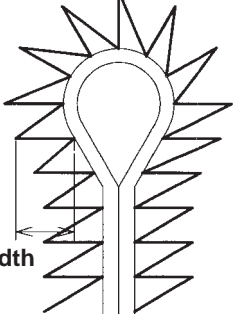
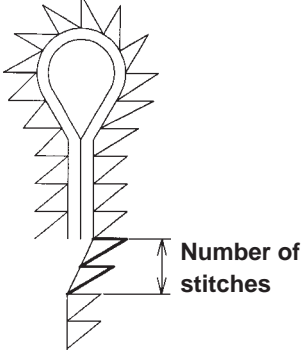
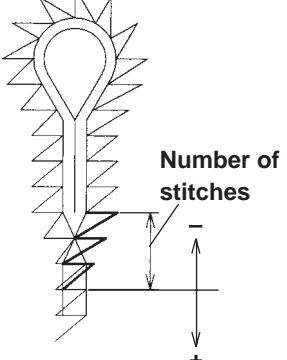
<p>No.8 Compensation of knife position</p>	<p>No. 9 Compensation of number of stitches at sewing end</p>	<p>No. 10 Compensation of turning</p>	<p>No. 11 Compensation of turning at parallel section</p>
			
<p>No. 13 Crosswise compensation of eyelet</p>	<p>No. 14 Lengthwise compensation of eyelet</p>	<p>No. 15 Lengthwise compensation of left eyelet</p>	<p>No. 16 Lengthwise compensation of left parallel</p>
			
<p>No. 17 Setting of stitch bite idth of right bottom of eyelet</p>	<p>No. 18 Setting of stitch bite width of left bottom of eyelet</p>	<p>No. 19 Setting of sitch bite width</p>	<p>No.23 Number of stitches slant taper bar</p>
			
<p>No. 24 Compensation of number of stitches of right taper bar</p>			
			

② Thread tension compensation table

[Setting of needle thread tension]

Compensation position No.	Setting item	Description
40	Needle thread tension	Needle thread tension value
41	Compensation of needle thread tension of right parallel section	Compensation value of needle thread tension of right side of parallel section
42	Compensation of needle thread tension of left parallel section	Compensation value of needle thread tension of left side of parallel section
43	Compensation of needle thread tension of top eyelet	Compensation value of thread tension of top eyelet
44	Compensation of needle thread tension of right bottom of eyelet	Compensation value of needle thread tension of right bottom of eyelet
45	Compensation of needle thread tension of left bottom of eyelet	Compensation value of needle thread tension of left bottom of eyelet
46	Compensation of needle thread tension of right taper bar	Compensation value of needle thread tension of right taper bar
47	Compensation of needle thread tension of left taper bar	Compensation value of needle thread tension of left taper bar
48	Compensation of needle thread of straight bar	Compensation value of needle thread tension of straight bar
51	Compensation of needle thread tension of sewing start	Compensation value of needle thread tension of sewing start
52	Compensation of needle thread tension of sewing end	Compensation value of needle thread tension of sewing end
53	Compensation of needle thread tension at the time of thread trimming	Compensation value of needle thread tension at the time of thread trimming of sewing machine * 1
54	Compensation of needle thread tension at the time of stop	Compensation value of needle thread tension at the time of stop of sewing machine * 2

* 1 : Compensation value as against memory switch No. 7 (needle thread tension at the time of thread trimming)

* 2 : Compensation value as against memory switch No. 9 (needle thread tension at the time of stop)

(See the item "7. Memory switch".)

[Setting of looper thread tension]

Compensation position No.	Setting item	Description
60	Looper thread tension	Looper thread tension value
61	Compensation of looper thread tension of right parallel section	Compensation value of looper thread tension of right side of parallel section
62	Compensation of looper thread tension of left parallel section	Compensation value of looper thread tension of left side of parallel section
63	Compensation of looper thread tension of top eyelet	Compensation value of looper thread tension of top eyelet
64	Compensation of looper thread tension of right bottom of eyelet	Compensation value of looper thread tension of right bottom of eyelet
65	Compensation of looper thread tension of left bottom of eyelet	Compensation value of looper thread tension of left bottom of eyelet
66	Compensation of looper thread tension of right taper bar	Compensation value of looper thread tension of right taper bar
67	Compensation of looper thread tension of left taper bar	Compensation value of looper thread tension of left taper bar
68	Compensation of looper thread tension of straight bar	Compensation value of looper thread tension of straight bar
71	Compensation of looper thread tension of sewing start	Compensation value of looper thread tension of sewing start
72	Compensation of looper thread tension of sewing end	Compensation value of looper thread tension of sewing end
73	Compensation of looper thread tension at the time of thread trimming	Compensation value of looper thread tension at the time of thread trimming of sewing machine * 1
74	Compensation of looper thread tension at the time of stop	Compensation value of looper thread tension at the time of stop of sewing machine * 2

* 1 : Compensation value as against memory switch No. 8 (looper thread tension at the time of thread trimming)

* 2 : Compensation value as against memory switch No. 10 (looper thread tension at the time of stop)

(See the item "7. Memory switch".)

[Compensation position of taper bar]

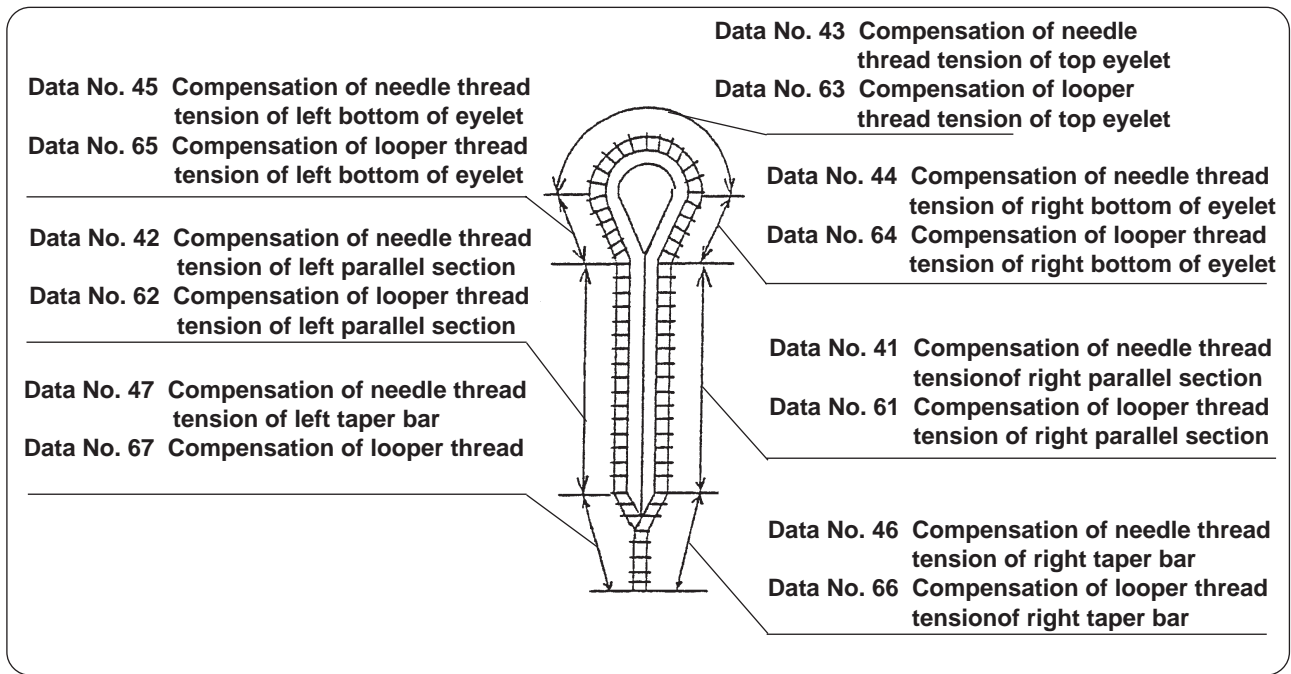

[Compensation position of straight bar]

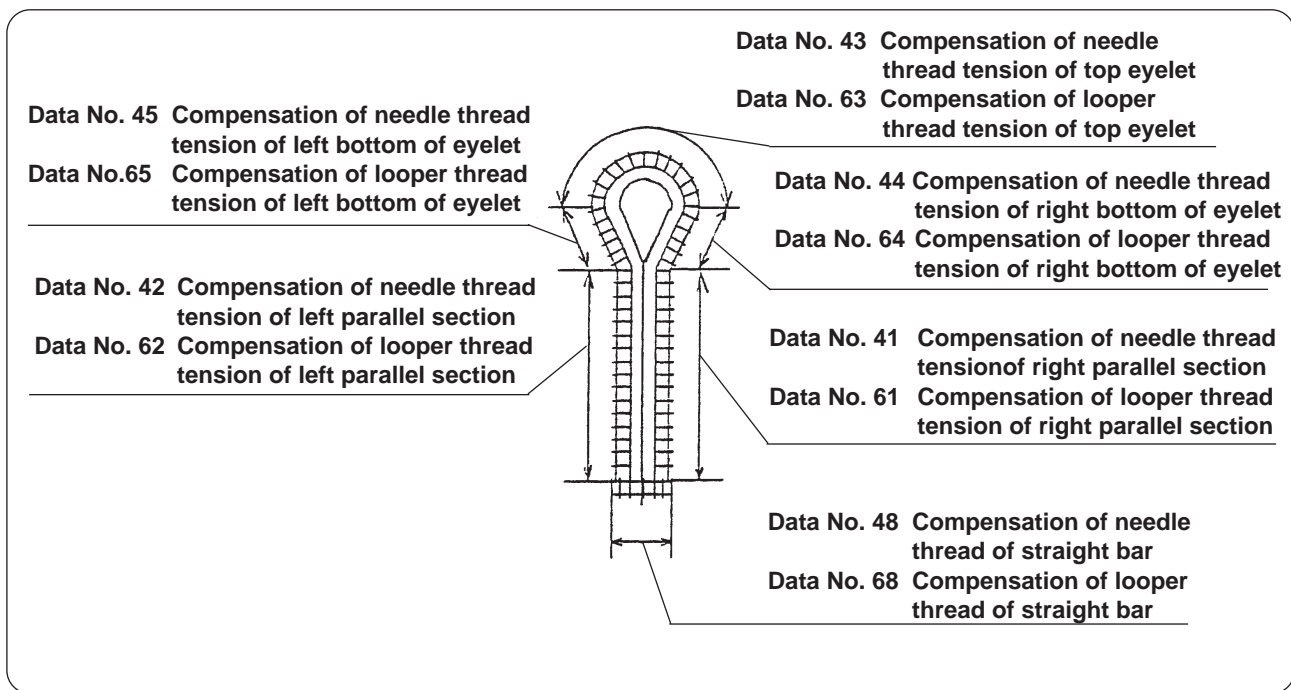

7. MEMORY SWITCH

(In case of the machine with multicutting device, refer to “15. MULTICUTTING DEVICE”.)

(1) Setting the memory switch

The memory switch mode can be set by turning ON the power while pressing READY key ② for the user level (level 1), and turning ON the power while simultaneously pressing READY key ② and THREAD key ④ for the service level (level 2). Then various data can be changed.

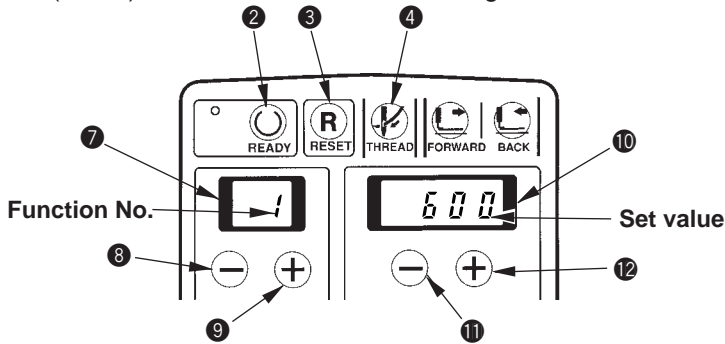

- 1) The function No. is displayed in 2-digit LED ⑦. Select the function No. with LEFT (+) key ⑨ or LEFT (-) key ⑧.
- 2) The set value is displayed in 4-digit LED ⑩. The set value can be changed with RIGHT (+) key ⑫ or RIGHT (-) key ⑪.
- 3) Press READY key ② after the set value has been changed. The memory switch set value is stored in EEPROM.

- (Caution)**
1. The data cannot be stored when the memory switch set value is changed or the power is turned OFF without pressing READY key ②.
 2. When RESET key ③ is pressed, the memory switch setting which has been changed will become invalid.

(2) Initializing the memory switch

- 1) How to return the set value of the memory switch to that at the time of delivery from the factory
 - ① Simultaneously pressing READY key ② and LEFT (+) key ⑨, turn ON the power.
 - ② The function No. is displayed in 2-digit LED ⑦. (Model setting)
 - ③ Press READY key ② to initialize the memory switch.



- 2) When performing model change

Perform the procedure up to aforementioned steps ① and ②.

- ① Press RIGHT (+) key ⑫ or RIGHT (-) key ⑪ to select the model.

Type	S type Domestic	J type Domestic	R type Domestic	S type Export	J type Export	R type Export	C type Domestic/export	T type Domestic/export
Model set value	0	1	2	3	4	5	6	7

- ② Press READY key ② to initialize the memory switch.

(3) Setting the DIP switch

- 1) For long thread trimming, short thread trimming, selection of short thread trimming (sewing length), T type or multicutting, setting of combination of DIP switches is performed.
 - ① Setting of the long thread trimming and short thread trimming can be performed by combination of DIP switches 1 and 2.
 - ② Setting of the selection of short thread trimming can be performed by DIP switches 1 and 2 according to the sewing length.
 - ③ Setting of T type (short thread trimming without gimp) can be performed by turning ON of DIP switch 3.
 - ④ Setting of the multicutting can be performed by turning ON of DIP switch 4.

(Caution) When performing model setting, be sure to perform initialization of the memory switch and setting of the DIP switch. Error No. 90 may occur.

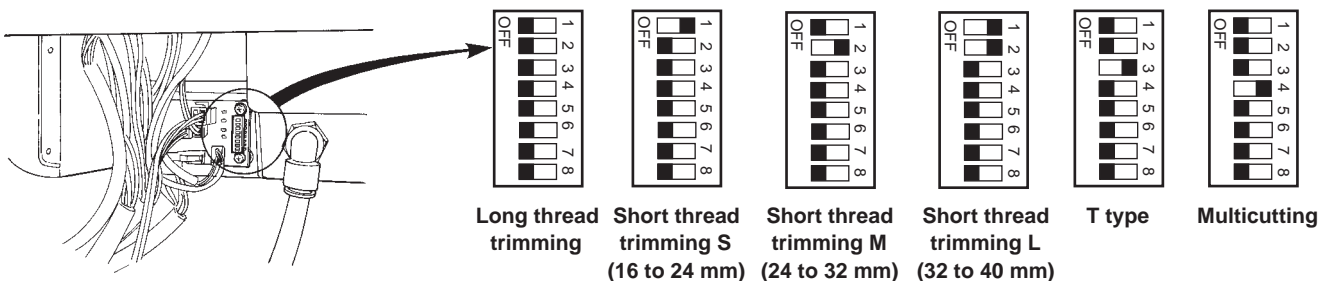

(4) Memory switch list (In case of the machine with multicutting device, refer to “15. MULTICUTTING DEVICE”.)

No	Function	Description	Standard value	Setting range	Unit	Level
1	Soft-start, rpm of 1st stitch (inside → outside)	The rpm of 1st stitch (inside → outside) from the start of sewing machine	600rpm	400 to 1200	100rpm	1
2	Soft-start, rpm of 1st stitch (outside → inside)	The rpm of 1st stitch (outside → inside) from the start of sewing machine.	600rpm	400 to 2200	100rpm	1
3	Soft-start, rpm of 2nd stitch (inside → outside)	The rpm of 2nd stitch (inside → outside) from the start of sewing machine	600rpm	400 to 2200	100rpm	1
4	Soft-start, rpm of 2nd stitch (outside → inside)	The rpm of 2nd stitch (outside → inside) from the start of sewing machine	600rpm	400 to 2200	100rpm	1
5	Soft-start, rpm of 3rd stitch (inside → outside)	The rpm of 3rd stitch (inside → outside) from the start of sewing machine	600rpm	400 to 2200	100rpm	1
6	Soft-start, rpm of 3rd stitch (outside → inside)	The rpm of 3rd stitch (outside → inside) from the start of sewing machine	600rpm	400 to 2200	100rpm	1
7	Needle thread tension at the time of thread trimming	Output value of needle thread tension at the time of thread trimming	0	0 to 255	Output value	1
8	Looper thread tension at the time of thread trimming	Output value of looper thread tension at the time of thread trimming	0	0 to 255	Output value	1
9	Needle thread tension at the time of machine-stop (Caution) 1	Output value of needle thread tension at the time of machine-stop	60	0 to 255	Output value	1
10	Looper thread tension at the time of machine-stop	Output value of looper thread tension at the time of machine-stop	0	0 to 255	Output value	1
11	Set position selection	0 : Origin position, 1 : Front position	0	0 to 1	–	1
12	Production counter selection	0 : No selection, 1 : UP counter, 2 : DOWN counter	1	0 to 2	–	1
13	Start prohibition due to production counter over	0 : Permitted, 1 : Prohibited	1	0 to 1	–	1
14	Start SW, selection of “I” switch	0 : Start, 1 : Presser comes down → Start	0	0 to 1	–	1
15	Preparation of operation with start SW	0 : Ineffective, 1 : Effective	0	0 to 1	–	2
16	2-step pedal	0 : Double pedal, 1 : 2-step pedal	0	0 to 1	–	2
17	F1, Data No. registration	Data No. to be registered to F1 switch	8	0 to 80	–	1
18	F2, Data No. registration	Data No. to be registered to F2 switch	80	0 to 80	–	1
19	Setting of thread tension compensation	0 : Setting not permitted, 1 : Setting permitted (with NEEDLE key)	0	0 to 1	–	1
20	Prohibition of pattern data setting	0 : Permitted, 1 : Setting prohibited (thread tension permitted)	0	0 to 1	–	1
21	Pattern data deletion	0 : Deletion not permitted, 1 : Deletion permitted (Writing No. = 0 performs deletion.)	0	0 to 1	–	2
22	Looper thread trimming control	0 : Without looper thread trimming, 1 : With looper thread trimming	1	0 to 1	–	1
23	Presser comes down when returning to origin	0 : Normal, 1 : Presser comes down when returning to origin	0	0 to 1	–	1
24	Temporary stop of cut-after knife	0 : Normal, 1 : Temporary stop and cut-after knife operation by start SW	0	0 to 1	–	1
25	Origin retrieval after completion of sewing	0 : Without 1 : With (Crosswise → lengthwise) 2 : With (Crosswise and lengthwise simultaneously)	S, R, T types : 1 J, C types : 2	0 to 2	–	2
26	Cloth open at the time of straight bar pattern	0 : Normal, 1 : Cloth open at the time of straight bar and of start.	0	0 to 1	–	1
27	Stitch bite width	Mechanical stitch bite width S, R, T types : 2.8 mm (domestic), 2.3 mm (export) J type : 3.6 mm (domestic), 2.5 mm (export) C type : 2.5 mm T type : 2.3 mm		2.0 to 4.0	0.1mm	2
28	Lengthwise origin position	Longitudinal position when setting position is in origin position	0mm	0 to 64	1mm	2
29	Lengthwise position in front	Longitudinal position when setting position is in front position	22mm	0 to 64	1mm	1
30	Air SW control	0 : Ineffective, 1 : Effective	1	0 to 1	–	2
31	Head lifting SW control	0 : Ineffective, 1 : Effective	1	0 to 1	–	2
32	Delay time for lowering presser	Delay time from lowering of presser to start/move of origin	100ms	0 to 1000	10ms	2
33	Delay time for lifting presser	Delay time from lifting of presser to looper thread trimming (short) ON	S, R, T types : 100 ms J, C types : 40 ms	0 to 1000	10ms	2
34	Delay time for opening presser	Delay time from opening of cloth open to start of sewing machine	50ms	0 to 1000	10ms	2
35	Delay time for needle thread release ON	Delay time from needle thread release to start of sewing machine	50ms	0 to 1000	10ms	2
36	Delay time for needle thread trimming ON	Needle thread trimming ON time	50ms	0 to 1000	10ms	2
37	Delay time for looper thread trimming ON	Looper thread trimming ON time	150ms	0 to 1000	10ms	2
38	Time for dust chute	Dust chute ON time	500ms	0 to 3000	10ms	2
39	Delay time for lowering auxiliary presser	Delay time from lowering of auxiliary presser to lifting of presser	0ms	0 to 1000	10ms	2
* 40	Knife adjustment pattern setting acceptable	0 : Setting knife holder No. to pattern data unacceptable 1 : Setting acceptable	0	0 to 1	–	1
* 41	Knife motor adjustment value 1	Adjustment value 1 of number of pulses of knife moving at the time of cloth cutting (Knife holder No. 1)	0 pulses	-100 to 300	1 pulse	1
* 42	Knife motor adjustment value 2	Adjustment value 2 of number of pulses of knife moving at the time of cloth cutting (Knife holder No. 2)	0 pulses	-100 to 300	1 pulse	1
* 43	Knife motor adjustment value 3	Adjustment value 3 of number of pulses of knife moving at the time of cloth cutting (Knife holder No. 3)	0 pulses	-100 to 300	1 pulse	1
* 44	Knife motor adjustment value 4	Adjustment value 4 of number of pulses of knife moving at the time of cloth cutting (Knife holder No. 4)	0 pulses	-100 to 300	1 pulse	1
* 45	Knife motor adjustment value 5	Adjustment value 5 of number of pulses of knife moving at the time of cloth cutting (Knife holder No. 5)	0 pulses	-100 to 300	1 pulse	1
* 46	Knife motor adjustment value 6	Adjustment value 6 of number of pulses of knife moving at the time of cloth cutting (Knife holder No. 6)	0 pulses	-100 to 300	1 pulse	1
* 47	Knife motor adjustment value 7	Adjustment value 7 of number of pulses of knife moving at the time of cloth cutting (Knife holder No. 7)	0 pulses	-100 to 300	1 pulse	1
* 48	Knife motor adjustment value 8	Adjustment value 8 of number of pulses of knife moving at the time of cloth cutting (Knife holder No. 8)	0 pulses	-100 to 300	1 pulse	1
* 49	Knife motor adjustment value 9	Adjustment value 9 of number of pulses of knife moving at the time of cloth cutting (Knife holder No. 9)	0 pulses	-100 to 300	1 pulse	1

(Caution) 1. At the time of No.B8=1 : set to 150.

* In case of the machine with multicutting device, No. with the asterisk becomes the adjustment value of the motor to actuate the knife to cut the eyelet section.

No	Function	Description	Standard value	Setting range	Unit	Level
* 50	Knife motor adjustment value 0	Adjustment value 0 of number of pulses of knife moving at the time of cloth cutting (Knife holder No. 0)	30 pulses	-100 to 300	1 pulse	1
51	Position where pulse can start knife motor jump feed	Position of pulse of start of crosswise/lengthwise jump feed at the time of cloth cutting	S, J, C, T types : 400 pulses R type : 0 pulses	0 to 1500	1 pulse	2
52	Position where pulse can start knife motor thread trimming	Position of pulse of start of thread trimming at the time of cloth cutting	1020 pulses	0 to 1500	1 pulse	2
53	Number of pulses of plural times knife move of knife motor	Number of pulses of plural times knife move at the time of cloth cutting	1130 pulses	0 to 1500	1 pulse	2
54	Position of pulse of plural times knife jump feed of knife motor	Position of pulse of plural times knife lengthwise jump feed at the time of cloth cutting	800 pulses	0 to 1500	1 pulse	2
55	Stop time of knife motor in lower position	Stop time from reaching lower position to starting lifting	50ms	50 to 500	10ms	1
56	Number of pulses of knife motor move	Number of pulses of knife moving at the time of cloth cutting	1130 pulses	500 to 1500	1 pulse	2
57	Number of low speed pulses of lowering knife motor	Number of low speed pulses when knife lowering finished at the time of cloth cutting	60 pulses	0 to 300	1 pulse	1
58	Number of low speed pulses of raising knife motor	Number of low speed pulses when knife raising starts at the time of cloth cutting	80 pulses	80 to 300	1 pulse	1
59	Knife motor move speed	Knife move speed at the time of cloth cutting	4800 pps	50 to 9990	10pps	2
63	Number of low speed pulses of plural times knife lowering of knife motor	Number of low speed pulses when plural times knife lowering finished at the time of cloth cutting	60 pulses	0 to 300	1 pulse	1
64	Number of low speed pulses of plural times knife raising of knife motor	Number of low speed pulses when plural times knife raising starts at the time of cloth cutting	80 pulses	80 to 300	1 pulse	1
65	Needle thread clamp with/without	0 : Without 1 : With	0	0 to 1	-	1
66	Number of stitches of needle thread clamp open	Number of stitches to turn ON needle thread open from sewing start	5	0 to 99	Number of stitches	1
67	Lowering timing of needle thread clamp	Time from presser origin move to needle thread clamp lowering	0	-100 to 100	10 ms	2
68	Needle thread clamp lowering delay time	Time until needle thread clamp lowers.	100	0 to 1000	10 ms	2
69	Lengthwise move amount from sewing end of needle thread clamp closing (Caution) 2	Y move amount from sewing end of needle thread clamp closing	23	0 to 50	1 mm	2
70	Jump feed speed of crosswise axis	Speed of crosswise axis at the time of jump feed	1000pps	50 to 5000	10pps	2
71	Jump feed speed of lengthwise axis	Speed of lengthwise axis at the time of jump feed	S, R, T types : 2000pps J, C types : 5000pps	50 to 5000	10pps	2
72	Jump feed speed of turning axis	Speed of turning axis at the time of jump feed	500pps	50 to 2000	10pps	2
73	Jump feed speed of thread trimming of crosswise axis	Speed of crosswise axis at the time of jump feed of thread trimming	1000pps	50 to 5000	10pps	2
74	Jump feed speed of thread trimming of lengthwise axis	Speed of lengthwise axis at the time of jump feed of thread trimming	S, R, T types : 2000pps J, C types : 3000pps	50 to 5000	10pps	2
75	Jump feed speed of thread trimming of turning axis	Speed of turning axis at the time of jump feed of thread trimming	S, R types : 900pps J, C, T types : 2000pps	50 to 2000	10pps	2
86	Needle thread trimming ON, lengthwise traveling amount	Lengthwise traveling amount from end of sewing to needle thread trimming ON	S, R, J, C types : 4 mm T type : 3 mm	0 to 50	1mm	2
87	Long thread trimming, lengthwise position of start of turning of turning axis	Long thread trimming, Lengthwise position of start of turning of turning axis	10mm	0 to 16	1mm	2
88	Long thread trimming, angle compensation of turning axis	Long thread trimming, Angle compensation pulse of turning axis ... standard 125°	0 pulse	-30 to 30	1 pulse	2
89	Long thread trimming, gimp haul ON delay time	Long thread trimming, Delay time from turning of turning axis to gimp haul ON	0ms	0 to 1000	10ms	2
90	Angle of sewing end of round bar	Angle of sewing end of round bar	-5°	-120 to -5	°	2
91	Round bar setting	0 : Round bar setting not permitted, 1 : Round bar setting permitted	1	0 to 1	-	2
92	Delay time of looper thread hauling of long thread trimming	Time from looper thread haul OFF to looper thread trimming OFF	0	0 to 500	10 ms	2
93	Double action of looper thread hauling of long thread trimming	0 : 1 time 1 : 2 times	0	0 to 1	-	2
94	Presser/start SW replacement	0 : Normal 1 : Presser/start SW replacement	0	0 to 1	-	2
95	Delay time of needle thread clamp closing	Time from needle thread clamp closing to raising	50	0 to 1000	10 ms	2
96	Temporary stop time of needle thread clamp	Time from needle thread clamp raising to resuming of feed	50	0 to 1000	10 ms	2
97	Cloth cutting overlap time	Start time of cloth cutting knife motion before reaching cloth cut position	S, R, T types : 0 ms J, C types : 100 ms	0 to 200	10 ms	2
98	Cloth presser open delay check selection	0 : Move at the start of sewing after cloth open delay 1 : Simultaneously	S, R, T types : 0 J, C types : 1	0 to 1	-	2
99	Cloth presser/cloth cutting offset selection	0 : Normal (64 mm), 1 : 10 mm offset (54 mm)	S, R types : 0 J, C, T types : 1	0 to 1	-	2
A0	Cloth cutting knife 1, width of eyelet	Knife No. = 1 of width of eyelet	2.1mm	1.0 to 4.0	0.1mm	2
A1	Cloth cutting knife 1, length of eyelet	Knife No. = 1 of length of eyelet	3.2mm	1.0 to 8.0	0.1mm	2
A2	Cloth cutting knife 2, width of eyelet	Knife No. = 2 of width of eyelet	2.5mm	1.0 to 4.0	0.1mm	2
A3	Cloth cutting knife 2, length of eyelet	Knife No. = 2 of length of eyelet	3.8mm	1.0 to 8.0	0.1mm	2
A4	Cloth cutting knife 3, width of eyelet	Knife No. = 3 of width of eyelet	2.9mm	1.0 to 4.0	0.1mm	2
A5	Cloth cutting knife 3, length of eyelet	Knife No. = 3 of length of eyelet	4.4mm	1.0 to 8.0	0.1mm	2
A6	Cloth cutting knife 4, width of eyelet	Knife No. = 4 of width of eyelet	3.0mm	1.0 to 8.0	0.1mm	2
A7	Cloth cutting knife 4, length of eyelet	Knife No. = 4 of length of eyelet	4.6mm	1.0 to 4.0	0.1mm	2
A8	Cloth cutting knife 5, width of eyelet	Knife No. = 5 of width of eyelet	3.2mm	1.0 to 8.0	0.1mm	2
A9	Cloth cutting knife 5, length of eyelet	Knife No. = 5 of length of eyelet	5.4mm	1.0 to 4.0	0.1mm	2
B0	Cloth cutting knife 6, width of eyelet	Knife No. = 6 of width of eyelet	2.7 mm	1.0 to 4.0	0.1mm	2
B1	Cloth cutting knife 6, length of eyelet	Knife No. = 6 of width of eyelet	5.1 mm	1.0 to 8.0	0.1mm	2
B8	Needle thread haul two-step selection	0 : Normal, 1 : 2 steps of needle thread haul motion	0	0 to 1	-	1
B9	Needle thread haul OFF delay	Delay time from needle thread haul OFF to thread clamp	50ms	0 to 1000	10ms	2
C0	Lengthwise axis needle thread clamp jump feed speed	Lengthwise jump feed speed from end of sewing to the position of needle thread clamp	S, R types : 1,000 pps J, C types : 1,500 pps T type : 800 pps	50 to 5000	10pps	2
C1	Throat plate looper thread trimming ON lengthwise move amount	Move amount from end of sewing to throat plate looper thread trimming	10mm	0 to 50	1mm	2
E0	Sewing feed control mode	0 : Feed end 1 : Feed center 2 : Feed start reference	1	0 to 2	-	2

(Caution) 2. At the time of No.B8=1 : set to 14.

* In case of the machine with multicutting device, No. with the asterisk becomes the adjustment value of the motor to actuate the knife to cut the eyelet section.

No.	Function	Description	Standard value	Setting range	Unit	Level
E1	TG position at sewing feed end	TG position at feed end (When No. E0 is 0.)	41	1 to 45	Number of times of TG	2
E2	TG position at sewing feed center	TG position at feed center (When No. E0 is 1.)	S, R types : 18 J, C, T types : 27	1 to 45	Number of times of TG	2
E3	TG position at sewing feed start	TG position at feed start (When No. E0 is 2.)	13	1 to 45	Number of times of TG	2
E7	Offset value of needle thread tension	Offset amount of setting in terms of output value of needle thread tension	70	0 to 255	-	2
E8	Offset value of looper thread tension	Offset amount of setting in terms of output value of looper thread tension	80	0 to 255	-	2
F4	TG position at straight bar feed end	TG position of straight bar feed end in parallel section (When E0 is 0.)	41	1 to 45	Number of times of TG	2
F5	TG position at straight bar feed center	TG position of straight bar feed center in parallel section (When E0 is 1.)	27	1 to 45	Number of times of TG	2
F6	TG position at straight bar feed start	TG position of straight bar feed start in parallel section (When E0 is 2.)	13	1 to 45	Number of times of TG	2
F9	Type setting	Setting of motion according to the type of machine	0 : S type (domestic), 1 : J type (domestic), 2 : R type (domestic), 3 : S type (export), 4 : J type (export), 5 : R type (export), 6 : C type, 7 : T type	0 to 7	-	*

8. TEST MODE

○ Starting procedure

- 1) Simultaneously pressing [RESET (R)] key ③ and [LEFT (-)] key ⑧, turn ON the power to start the test mode. When the test mode is started, the display appears in 2-digit LED ⑦ and 4-digit LED ⑩ as shown in the figure below.
- 2) The number displayed in the 2-digit LED ⑦ is the function No.
Select the function No. you desire to use with [LEFT (+)] key ⑨ or [LEFT (-)] key ⑧.
- 3) Press [READY (O)] key ② to start the test mode.

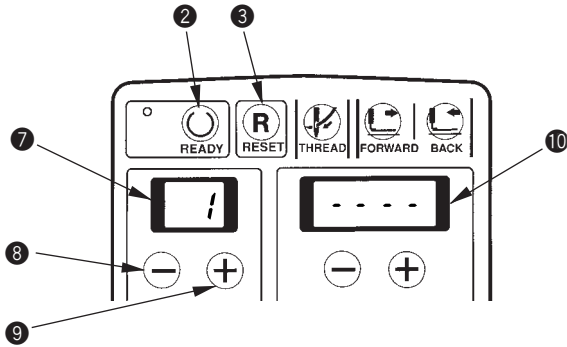

Function No.	Check function
1	Input check
2	Output check
3	Panel check
4	Origin check
5	Cloth cutting knife origin check
6	Sewing machine check
7	Thread tension check
8	Thread trimming check

(1) Input check

The input state of the key input, the sensors and the respective switches of the operation panel can be checked.

- 1) Select the function No. 1.
- 2) Press [LEFT (+)] key ⑨ or [LEFT (-)] key ⑧ to select the item No. "1" to "19" from the table below.
(See the table.) The selected No. is displayed in 2-digit LED ⑦.
- 3) The input state of the selected item is displayed in 4-digit LED ⑩.

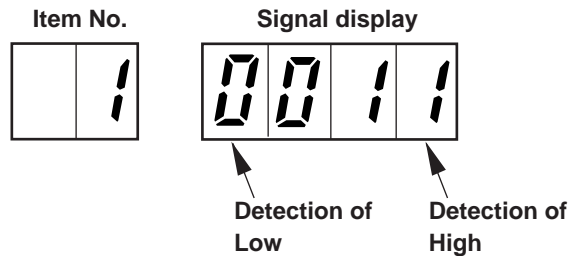

Digit display Item No.	1000 digits	100 digits	10 digits	1 digit
1	BACK KEY	THREAD (Threading) KEY	RESET KEY	READY KEY
2	NUMERIC + KEY	NUMERIC - KEY	PATTERN + KEY	PATTERN - KEY
3	-	-	-	-
4	DATA KEY	PATTERN KEY	FORWARD KEY	-
5	SPACE KEY (Eyelet)	LOOPER (Looper thread tension) KEY	NEEDLE (Needle thread tension setting) KEY	COUNTER KEY
6	LENGTH KEY (Cut space)	NUMBER OF STITCHES OF PARALLEL Key	LENGTH (Cut length) KEY	STITCHES (Number of stitches of eyelet) KEY
7	SPEED KEY	LENGTH (Length of taper bar) KEY	STITCHES (Number of stitches of taper bar) KEY	OFFSET (Taper bar offset) KEY
8	CA (Cut-after) KEY	CB (Cut-before knife) KEY	KNIFE ON/OFF KEY	EYELET (Eyelet speed) KEY
9	ADJUST (Knife adjust) SW	RESEWING KEY	AUTO KEY	SHAPE (Knife No.) KEY
10	-	-	FUNCTION F2 KEY	FUNCTION F1 KEY
11	-	TEMPORARY STOP SW	START SW	PRESSER KEY
12	-	HEAD SAFETY SW	THERMAL SW	AIR PRESSURE SW
13	MACHINE TYPE 8	MACHINE TYPE 4	MACHINE TYPE 2	MACHINE TYPE 1
14	PRESSER TYPE 8	PRESSER TYPE 4	PRESSER TYPE 2	PRESSER TYPE 1
15	LOOPER THREAD TRIMMING RETURN SENSOR			KNIFE ORIGIN SENSOR
16	RESERVE	RESERVE	RESERVE	RESERVE
17	TURNING AXIS ORIGIN SENSOR	LENGTHWISE AXIS ORIGIN SENSOR	CROSSWISE AXIS ORIGIN SENSOR	-
18	DDET	UDET	TG	PDET
19	SDET	MERR	MBRK	MSTAT

(2) Output check

ON/OFF of the solenoid valve can be operated from the operation panel. Checking of the operation of each unit can be operated from the operation panel.

- 1) Select the function No. 2.
- 2) Press [LEFT \oplus] key ⑨ or [LEFT \ominus] key ⑧ to select the item No. "1" to "15" from the table below. (See the table.) The selected No. is displayed in 2-digit LED ⑦.
- 3) Every time [RIGHT \oplus] key ⑫ or [RIGHT \ominus] key ⑪ is pressed, ON/OFF of the output can be performed.

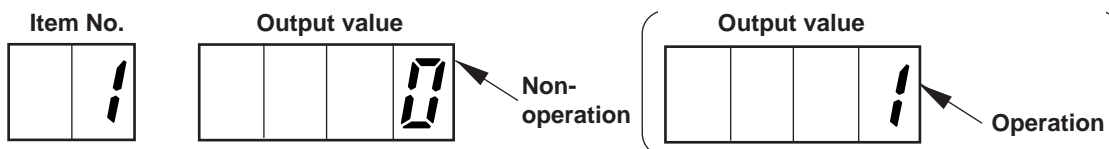

Item No.	Output destination
1	Cloth presser
2	Cloth open
3	Needle thread tension release
4	Needle thread trimming
5	Looper thread trimming
6	Dust chute
7	Gimp haul/auxiliary presser

Item No.	Output destination
8	Needle thread clamp open
9	Needle thread clamp close
10	Not used.
11	Not used.
12	Not used.
13	Not used.
14	Not used.
15	Not used.

(3) Operation panel check

Input check of 7 segment LEDs and the respective keys of the operation panel can be performed.

- 1) Select the function No. 3.
- 2) When the operation panel check is selected, "1" segment each of 7 segment LEDs of 2 digits and 4 digits lights up, and checking of 7 segment LEDs can be performed.
- 3) When each key of the operation panel is pressed, the switch No. of the key is displayed in the 4-digit LED while the key is held pressed.

No	Key
1	Ready
2	Reset
3	Threading
4	Back
5	Pattern -
6	Pattern +
7	Numeric -
8	Numeric +
9	-
10	-
11	-
12	-
13	-
14	Forward
15	Pattern
16	Data
17	Counter
18	Needle thread tension
19	Looper thread tension
20	Eyelet space

No	Key
21	Number of stitches of eyelet
22	Cut length
23	Number of stitches of parallel section
24	Cut space
25	Taper bar offset
26	Number of stitches of taper bar
27	Length of taper bar
28	Sewing speed
29	Speed of eyelet
30	Knife On/Off
31	Cut-before knife
32	Cut-after knife
33	Knife No.
34	Auto
35	Cloth open
36	Knife adjustment
37	Function F1
38	Function F2
39	-
40	-

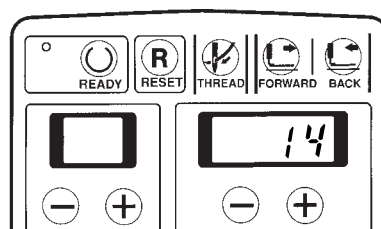

Example of operation panel check display

When FORWARD key is pressed.



(4) Crosswise feed / lengthwise feed / turning origin check



This function is used when checking or adjusting the origin of crosswise feed, lengthwise feed or turning.

- 1) Select the function No. 4.
- 2) After starting the check mode, press [READY ] key **2** to perform the origin retrieval and returning to needle UP position, and enter the operation mode. At this time, when the needle bar is not in the needle UP position, "Er 12" is displayed. In this case, turn the handwheel until the error display disappears.
- 3) Select the axis you desire to operate with [LEFT ] key **3**. The No. you selected is displayed at 10 digits of 2-digit LED **7**.
 Display contents 1 : Crosswise axis 2 : Lengthwise axis 3 : Turning axis
- 4) Select the contents you desire to display in 4-digit LED **10** with [LEFT ] key **9**. The No. you selected is displayed at "1" digit of 2-digit LED **7**.
 Display contents 0 : Sensor display 1 : Crosswise coordinate
 2 : Lengthwise coordinate 3 : Turning coordinate

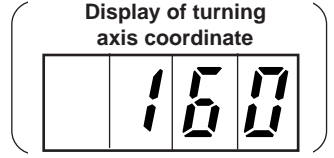
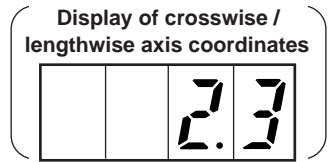
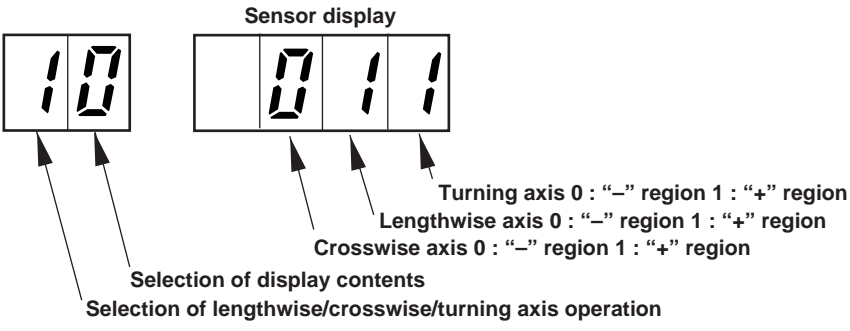
① 7 segment display at the time of display selection



Lengthwise/crosswise axis coordinates are displayed in mm.
 Turning axis coordinate is displayed in pulse.

- 5) The selected axis can be operated by +1 each with [RIGHT ] key **12** and by -1 each with [RIGHT ] key **11**.
- 6) The operation of presser switch → start switch can make all axes perform the origin retrieval and stop.
- 7) When selecting the lengthwise axis, the lengthwise axis can be moved "0 → 26 → 64 mm" with [DATA ] key **14**.

* The dimension value of the aforementioned 26 varies according to the sewing types.





- SS type : 26 mm (including RS, RD, TS types)
- JS type : 32 mm
- CS type : 40 mm

In addition, the dimension values of 0 and 64 mm are fixed. Besides, the dimension value, 64 mm is the longitudinal position of the cloth cutting knife.

- 8) When selecting the turning axis, the turning axis can be turned "0 → 160 pulses (180°)" with [DATA ] key **14**.

(5) Cloth cutting knife origin check





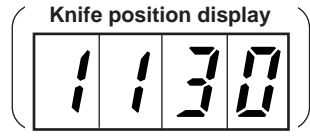
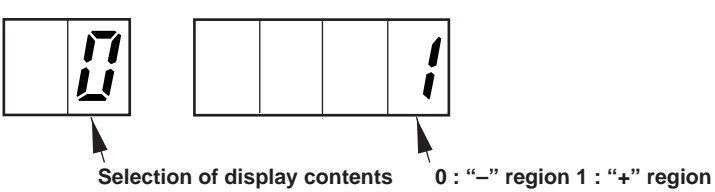





Checking of the operation of the cloth cutting knife can be performed by operating the cloth cutting knife from the operation panel.

- 1) Select the function No. 5.
- 2) After starting the check mode, press [READY ] key **2** to perform the origin retrieval and returning to needle UP position, and enter the operation mode.
 At this time, when the needle bar is not in the needle UP position, "Er 12" is displayed. In this case, turn the handwheel until the error display disappears.
- 3) Select the item No. you desire to display with [LEFT ] key **9** or [LEFT ] key **8**. The No. you selected is displayed at "1" digit of the 2-digit LED **7**.
 Display contents 0 : Origin sensor display 1 : Cloth cutting knife position display
- 4) The cloth cutting knife can be operated downward with [RIGHT ] key **12** and upward with [RIGHT ] key **11**.
- 5) The operation of presser switch → start switch can make all axes perform the origin retrieval and stop.







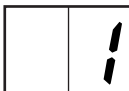
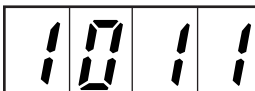

(6) Sewing machine check

Checking of the signals of the number of revolutions of the sewing machine or the main shaft can be operated and checked from the operation panel.

- 1) Select the function No. 6.
- 2) After starting the check mode, press [READY ] key  to perform the origin retrieval and returning to needle UP position, and enter the operation mode. At this time, when the needle bar is not in the needle UP position, "Er 12" is displayed. In this case, turn the handwheel until the error display disappears.
- 3) The number of revolutions can be checked with [AUTO ] key  and the sewing machine state signal with [OPEN ] key .
- 4) The display contents of the sewing machine state display can be changed over with [LEFT ] key  or [LEFT ] key .

Item No.	Signal state display	Digit				
		No.	1000	100	10	1
						
						
		1	DDET	UDET	TG	PDET
		2	SDET	M_ERROR	M_BREAK	M_STATE

- 5) Number of revolutions check mode
- 6) Change over to the number of revolutions display with [AUTO ] key .
- 7) Start up the sewing machine by the operation of presser switch → start switch.
- 8) The number of revolutions can be made +1 with [LEFT ] key , and -1 with [LEFT ] key .
- 9) To stop the sewing machine, stop it with the temporary stop switch.











Display at the time of checking the number of revolutions of the sewing machine

Command speed Observed number of revolutions



(7) Thread tension check

The needle thread tension and the looper thread tension can be changed from the panel and checking of the tension can be performed.

- 1) Select the function No. 7.
- 2) After starting the thread tension check mode, press [READY ] key  to enter the thread tension check mode.
- 3) Select the needle thread tension or the looper thread tension with [LEFT ] key  or [LEFT ] key .
- 4) Display of the 2-digit LED  : 1 : Needle thread tension 2 : Looper thread tension
- 5) The thread tension can be made +1 with [RIGHT ] key  and -1 with [RIGHT ] key .



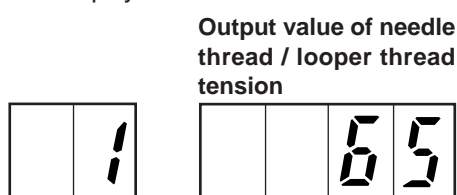





The display contents are as shown below.



1 : Needle thread tension, 2 : Looper thread tension

(8) Thread trimming check

Each step of the thread trimming operation can be operated and checking of the thread trimming operation can be performed.

- 1) Select the function No. 8.
- 2) After starting the thread trimming mode, press [READY ] key  to enter the thread trimming check mode.
- 3) When the thread trimming check mode is started, the displays of 2-digit LED  and 4-digit LED  become the same as those of the normal mode.
- 4) Same as the normal operation, after pressing [READY ] key , start up the sewing machine by the operation of presser switch → start switch.
- 5) Operate the sewing machine at each step with the start switch and make sure of thread trimming.
- 6) To return from stop state at each step to standby state, press [RESET ] key  to return to the standby state.
- 7) To stop the sewing machine, stop it with the temporary stop switch.

9. ERROR LIST

No	Description	How to reset
1	Sewing machine motor error Sewing machine motor does not run or signal does not enter even when it is running.	Turn OFF the power.
3	Looper thread trimming knife return error When the looper thread trimming knife has not returned at the time of operation of the sewing machine or operation of looper thread trimming	Remove the cause of error and press the RESET key.
4	Lengthwise direction stepping motor origin sensor error When lengthwise direction origin sensor has not changed at the time of origin retrieval.	Turn OFF the power.
5	Crosswise direction stepping motor origin sensor error When crosswise direction origin sensor has not changed at the time of origin retrieval	Turn OFF the power.
6	Turning stepping motor origin sensor error When turning origin sensor has not changed at the time of origin retrieval	Turn OFF the power.
7	Cloth cutting knife stepping motor origin sensor error When cloth cutting knife origin sensor has not changed at the time of origin retrieval	Turn OFF the power.
8	Air pressure lowering error When air pressure is lowered	Supply air and press the RESET key.
9	Head safety switch error When the sewing machine is operated with machine head raised	Return the machine head to its home position and press the RESET key.
10	Temporary stop switch When temporary stop switch is pressed while the sewing machine is operated	Press the RESET key.
12	Needle UP error When the needle bar is not in the upper position of the inside needle side	Upper position detection by turning handwheel by hand
20	Presser type error Data setting and presser type (thread trimming type) are different from each other (Caution) 1	Perform pattern change/data change after pressing the RESET key.
21	Data setting range error Outside of setting range error at the time of data setting (Caution) 2	Change the data after pressing the RESET key.
22	Data setting sewing length error Sewing length is over the sewing possible area at the time of data setting. (Caution) 3	Change the data after pressing the RESET key.
23	Thread tension setting range error Outside of setting range error at the time of thread tension setting (Caution) 4	Change the thread tension after pressing the RESET key.
24	Data setting bartack duplication Taper bar, straight bar or round bar is duplicated.	Change the data after pressing the RESET key.
25	Data setting number of stitches of bartack compensation error Number of stitches of compensation of sewing end at the time of straight bar is over.	Change the data after pressing the RESET key.
29	Cycle sewing pattern error Pattern No. is not set in cycle sewing.	Perform pattern change/cycle sewing setting after pressing the RESET key.
90	Presser type setting error Setting of DIP-SW of presser type is wrong. (Caution) 5	Turn OFF the power. Change over the DIP-SW.
91	Backup memory error When backup data such as pattern No. or the like has not been stored in memory	Backup data will be initialized after pressing the RESET key.
92	Memory switch error When data of memory switch has broken	Memory switch data will be initialized in machine model setting after pressing the RESET key. (Caution) 6
93	Pattern data error When pattern data has broken.	Pattern data will be initialized after pressing the RESET key.
97	Defective feed error When synchronization of the sewing machine and the feed is not obtained	Turn OFF the power.
98	Fan error Error due to temperature detection inside the control box	Turn OFF the power. Clean the fan of the control box.
99	EEPROM write-in error Defective write-in at the time of memory switch or pattern data writing	Turn OFF the power.

(Caution) 1. When changing the presser types S, M, and L of J and C types by the presser selection DIP switch, the pattern used before the change cannot be used.

The standard patterns which can be used with the presser type S, M and L of J and C types are described in the table below.

Presser type	Standard pattern No.
S	90, 91, 92
M	93, 94, 95, 96
L	97, 98, 99

2. Set the data within the range below.

Sewing speed – (minus) eyelet reduced speed ≥ 400

Number of stitches of slant taper bar \leq number of stitches of taper bar

Compensation of number of stitches of right taper bar \leq number of stitches of taper bar

$-14 \leq$ compensation of turning + compensation of turning at parallel section ≤ 14

$-1.2 \leq$ cut space + compensation of left cut space ≤ 1.2

3. $L =$ cut length + taper bar length + Crosswise compensation of left eyelet + Crosswise compensation of left parallel section + compensation of number of stitches at sewing end
Set the above length within the range described in the table below.

S and R types		J and C types		T type
Without thread trimming memory switch 22 = 0	$10 \leq L \leq 50$ *	Presser type S	$16 \leq L \leq 24$ (26)	$10 \leq L \leq 34$
With thread trimming memory switch 22 = 1		Presser type M	$24 \leq L \leq 32$ (34)	
	$10 \leq L \leq 38$	Presser type L	$32 \leq L \leq 40$ (42)	

* Remove the looper thread trimming unit in case of exceeding 38 mm.

4. Set the thread tension within the range of $0 \leq$ thread tension + compensation value of thread tension ≤ 180 .

5. Setting of presser selection DIP switch other than the specified ones cannot be performed.

6. F9 (machine model setting) may be displayed when replacing SYSTEM ROM.
For the machine type setting, refer to “(4) Memory switch list of 7. MEMORY SWITCH”.

10. REPLACING THE FUSE

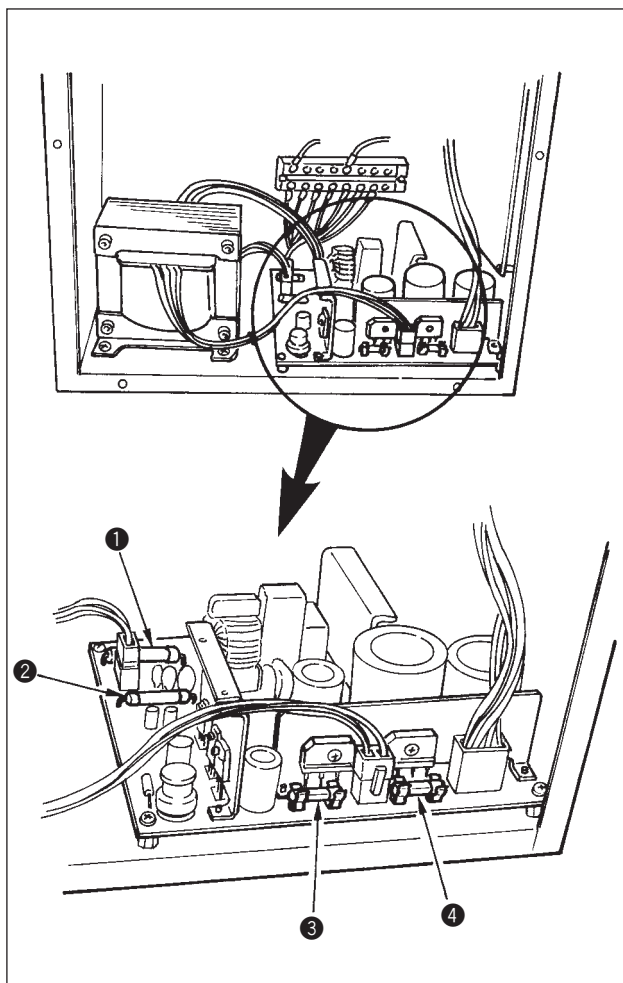

1) Turn OFF the power with the power switch after confirming that the sewing machine has stopped.

2) Draw the power cord from the power receptacle after confirming that the power switch is turned OFF. Then wait for more than 5 minutes.

3) Remove four screws fixing the rear cover of the control box. Then slowly open the rear cover.

4) Grasp the glass section of the fuse to be replaced and remove it.

5) Use the fuse with the specified capacity.

① and ② For servo-motor power protection
20 A each

(Standard melting fuse pcb direct-installing type)

③ For control power and active tension protection
10 A (Time-lag fuse)

④ For stepping motor protection
6.3 A (Time-lag fuse)

11. CHANGING THE VOLTAGE

(1) Changing the voltage between 100 and 240V

- When the voltage of 100V or 200V is supplied, the voltages as described in the table below can be used by changing the terminal board.

Line color (black)	Line color (brown)	Input voltage	Remarks
Terminal board No.			
1	2	100	CN32 required
1	3	110	
1	4	120	
1	5	200	CN32 not required
1	6	220	
1	7	240	

(Caution) Voltage change : 100 ↔ 200V

- When voltage of 100V, 110V or 120V is used, it is necessary to connect the input change cord (Part No. M85236000A0) to CN32 connector mounted on the POWER circuit board. When voltage of 200V, 220V or 240V is used, remove CN32 connector. If the setting of CN32 connector is mistaken, the control box is likely to be broken.

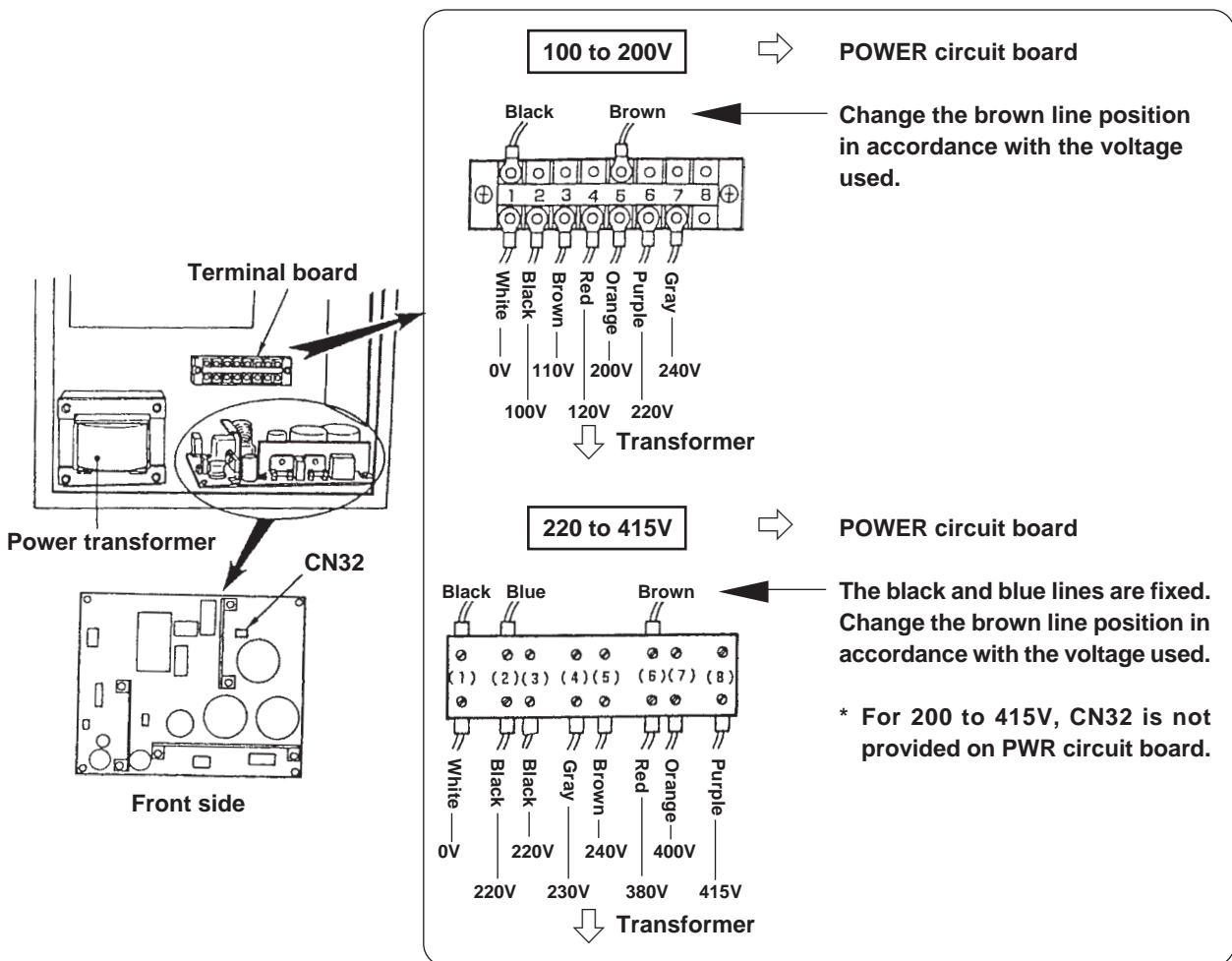



(2) Changing the voltage between 220 and 415V

- When the voltage of 220V or 415 V is supplied, the voltages as described in the table below can be used by changing the terminal board.

Line color (black)	Line color (Blue)	Line color (Brown)	Input voltage
Terminal board No.			
1	2	3	220
1	2	4	230
1	2	5	240
1	2	6	380
1	2	7	400
1	2	8	415

12. TROUBLES AND CORRECTIVE MEASURES

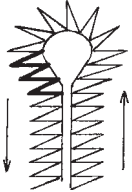
Troubles and corrective measure with regard to sewing

Phenomenon	Cause	Corrective measure	
1. Stitch skipping (general) <ul style="list-style-type: none"> • When kind of thread is affected • When sewing heavy-weight materials • When sewing heavy-weight materials with cut-before knife 	1-1) The clearance between the needle and the looper varies according to the turning angle (0°, 90° and 180°).	• Adjust the center of the needle. Especially, re-check is necessary when components around needle bar such as rotary upper timing belt and the like are adjusted or disassembled.	
	1-2) The needle is bent. There is a scratch on the needle. The needle is incorrectly attached.	• Check and replace the needle.	
	1-3) The needle dose not fit the kind of throat plate (needle size used).	• Use the throat plate suitable for the needle.	
	1-4) Kind of needle is wrong.	• Use DO x 558 needle. (DPx 5 cannot be used.)	
	1-5) Improper adjustment of the height of the needle bar	• Check and adjust the height of the needle bar.	
	1-6) The clearance between the needle and the looper is too large.	• Adjust the clearance at the time of inside needle or outside needle.	
	1-7) The clearance between the needle and the needle guard is too large or the needle and the needle guard come in excessive contact with each other.	• Check and adjust the clearance at the time of inside needle or outside needle.	
	1-8) Improper adjustment of the timing between the needle and the looper	• Adjust the timing with the stitch bite width used.	
	1-9) Improper adjustment of the timing to open/close the spreader The spreader comes in contact with the needle.	• Adjust the timing to open/close the spreader by the stitch bite width used.	
	1-10) Motion to open/close the spreader is not smooth.	• Remove the cloth waste from the spreader. Replace the spreader with a new one.	
	1-11) The clearance between the presser foot and the needle entry point is too large.	• Check the clearance and properly adjust it.	
	1-12) Thread tension is not proper.	• Set the thread tension to the proper value.	
	1-13) The blade point of looper has worn out.	• Correct the looper with oil-stone or the like, or replace it with a new one.	
	1-14) The looper or the spreader not suitable for the stitch bite width is used.	• Replace the looper or the spreader with a new one suitable for the stitch bite width.	
	1-15) Improper adjustment of the clearance between the needle and the looper	• Adjust the clearance at the time of inside needle or outside needle with the needle size used.	
	1-16) Improper adjustment of the timing to open/close the spreader The spreader comes in contact with the needle.	• Adjust the timing to open/close the spreader with the needle size used.	
	• When sewing heavy-weight materials with cut-before knife	1-17) Thread which is difficult to make loops is used. (Hard-to-slide thread or the like)	• Decrease the needle thread tension. Lower the installing position of thread take-up thread guide ④.
		1-18) Gauge without stamp of part No. is used.	• Decrease the number of revolution of the sewing machine.
1-19) The needle is bent at the thick section of the material and stitch skipping occurs.		① Change the needle to a thicker one. ② Adjust the stitch base line offset. ③ When the needle guard is 32040107, replace it with 32040115.	
2. Stitch skipping in case of narrow stitch bite width <ul style="list-style-type: none"> • Especially, stitch skipping occurs under neck of return eyelet or at slant section of return taper bar. 	2-1) When the throat plate does not correspond with narrow stitch bite width.	① Adjust the stitch base line offset. ② Adjust the looper adjustment to return uniform adjustment. ③ Change eyelet shape or taper bar shape. ④ Replace the throat plate with that for narrow stitch bite width.	
	2-2) The left-hand looper or the left-hand spreader is not for narrow stitch bite width.	① Execute the aforementioned ① to ③ individually or in combination. ② Replace the left-hand looper or the left-hand spreader with one for narrow stitch bite width.	
	2-3) If stitch bite width is narrowed, needle guard does not work on the outside needle side. (When 32040107 is used)	• Use the Rev.Up part (32040115). 	
3. Stitch skipping at the sewing start <ul style="list-style-type: none"> * Short thread trimming type only 	3-1) The length of remaining needle thread at the start of sewing is too short.	① Decrease the needle thread tension at the time of thread trimming. ② Use the needle thread clamp.	
	3-2) The left-hand spreader is installed incorrectly.	• Check the installing position and adjust it.	
	3-3) The timing of the right-hand looper is too early.	• Check the timing between the needle and the looper, and adjust it.	
	3-4) The clearance between the presser foot and the needle entry point is too large.	• Check the clearance and adjust it.	
	3-5) The looper is bent. There are scratches on the looper.	• Check the looper and replace it with a new one.	
	3-6) Feeding amount of the needle thread is insufficient.	• Adjust the feeding amount of needle thread	
	3-7) Looper thread clamp/looper thread presser is weak and the looper thread comes off at the start of sewing.	• Check and adjust the spring pressure.	
	3-8) Throat plate 32042806 (before Rev.Up) is used.	① Correct the left-hand spreader and adjust so that clearance (height) between the spreader and the left-hand looper is slightly smaller than the thickness of thread used. ② Increase the looper thread haul amount. ③ Replace the throat plate with one after Rev.Up (JA to JF).	

Phenomenon	Cause	Corrective measure
4. Stitch skipping near to top of eyelet	4-1) The clearance between the presser foot and the needle entry point is too large.	① Approach the presser foot. (Adjust the lateral position.) ② Approach the opening position of presser plate to the throat plate. (Adjust the cloth open.)
	4-2) The cloth is flopping.	① Decrease the sewing speed of eyelet section. ② Correct the presser foot or replace it with a new one. ③ Tilt the presser foot to the inside. (Adjustment) ④ In case of eyelet, use the presser and holding plate for eyelet.
	4-3) Needle thread loop is too large and falls. As a result, it is not caught by the looper.	• Lift the installing position of thread take-up thread guide ⑤.
	4-4) Needle thread loop cannot be made. As a result, the looper cannot catch the thread	• Decrease the needle thread tension. Lower the installing position of thread take-up thread guide ⑤.
5. Seam splitting at the sewing end	5-1) The feeding amount of needle thread is insufficient.	• Adjust the feeding amount of needle thread.
	5-2) The timing of the right-hand looper is too late.	• Check and adjust the timing between the needle and the looper.
	5-3) The opening amount of the right-hand spreader is insufficient.	• Check and adjust the opening amount of the spreader.
	5-4) The gimp is too hard.	• Replace the gimp. Check the thread path of gimp.
6. Needle thread breakage	6-1) The needle thread tension is too high.	• Adjust the sewing conditions to obtain an appropriate thread tension.
	6-2) The needle comes in contact with the blade point of the looper.	• Check and adjust the clearance.
	6-3) The thread paths in the needle, loopers, spreaders, throat plate, etc. have become worn out or contain scratches.	• Check and replace the respective parts.
	6-4) The thread is too thick or too thin for the needle.	• Replace the needle with a proper one.
	6-5) There are scratches in the needle hole or needle slot.	• Check and replace the needle.
	6-6) The needle size is not suitable for the kind of throat plate.	• Use a throat plate suitable for the needle size.
7. Looper thread breakage	7-1) The looper thread tension is too high.	• Adjust the sewing conditions to obtain an appropriate thread tension.
	7-2) The installing position of the left-hand spreader is incorrect.	• Check and adjust the installing position.
	7-3) Refer to "5. Needle thread breakage" for details on other causes and corrective measures.	
8. Needle breakage	8-1) The needle interferes with looper, spreader, etc.	• Adjust the clearance between the looper and the needle properly. Adjust the timing to open/close the spreaders properly.
	8-2) The clearance between the needle and the looper varies according to the turning angle (0°, 90° and 180°).	• Adjust the center of the needle.
	8-3) The clearance between the needle and the needle guard is too large or the needle and the needle guard come in excessive contact with each other.	• Check and adjust the clearance.
	8-4) The height of the needle bar has been improperly adjusted.	• Check and adjust the height of the needle bar.
	8-5) When the stitch bite width is narrowed, the needle guard does not work on the outside needle side. (When 32040107 is used.)	• Use the Rev.Up part (32040115).
	8-6) The needle does not fit the kind of throat plate (needle size used).	• Use the throat plate suitable for the needle.
	* When sewing heavy-weight materials 8-7) The needle bends at the thick section of the material and stitch skipping occurs.	• Change the needle to a thicker one. Adjust the stitch base line offset.
	* When sewing heavy-weight materials with cut-before knife * Without needle thread clamp 8-8) The needle bends at the cutting section of cloth cutting knife and stitch skipping occurs.	• Change the needle to a thicker one. Properly adjust the inside needle entry to the inside of cutting section.
	8-9) Needle thread is depressed by the presser foot at the start of sewing.	① Increase the feeding amount of needle thread. ② Decrease the needle thread tension at the time of stop. (ROM007* only) ③ Use the needle thread clamp.
	8-10) Material comes in contact with the needle tip after sewing.	① Lower the finger guard to sew. ② Lower the height of the presser. (Adjustment) ③ Use the machine by combining the front set function with memory switch No. 23 (presser down).
9. Stitches at the straight section of the buttonhole are not uniform.	9-1) The left- and right-hand sewing pitches at the straight section are different from each other.	• Compensate the length by lengthwise compensation of left parallel section of the data compensation.
	9-2) The left- and right-hand positions at the straight section are different from each other.	• Compensate the position by lengthwise compensation of left eyelet of the data compensation.
	9-3) Stitches which should be parallel are slant.	• Compensate the inclination by turning compensation of parallel section of the data compensation.
	9-4) The rear face side (indented part) of needle comes in contact with the slot of throat plate, or it is near the slot.	① Adjust the center of the needle. ② Perform additional work on the throat plate.

Phenomenon	Cause	Corrective measure
10. The left- and right-hand sides of the seam at the straight section of the buttonhole are not uniform.	10-1) The left- and right-hand side cloth opening amounts are not equal.	• Adjust so that the left- and right-hand side cloth opening amounts are equal.
	10-2) Improper adjustment of the knife dropping position	• Check and adjust the knife dropping position.
	10-3) There is shrinkage of cloth by sewing or step difference between left- and right-hand sides of cloth.	• Individually set the left- and right-hand sides of cut space.
	10-4) Material is not pressed partially	① Correct the presser foot. ② Increase the presser pressure.
11. The shape of the eyelet is deformed.	11-1) The seam is tilted.	• Set the turning compensation/parallel section turning compensation.
	11-2) The cloth is deformed by the seam.	• Set the eyelet crosswise compensation/lengthwise compensation.
	11-3) Improper adjustment of the knife dropping position	• Check and adjust the knife dropping position.
	11-4) The cloth at eyelet section is flopping.	• Correct the presser foot or replace it with a new one.
	11-5) The gimp is moved to the inside needle side.	• Replace the throat plate with the optional one.
12. The seam is cut by the cut-after knife.	12-1) The clearance between the cloth cutting knife and the needle is too small.	• Check the cut (eyelet) space and re-set it.
	12-2) Improper adjustment of the knife dropping position	• Check the knife dropping position, and correct or adjust it.
	12-3) There is shrinkage of cloth by sewing or step difference between left- and right-hand sides of cloth.	• Individually set the left- and right-hand sides of cut space.
13. Needle thread cannot be trimmed.	13-1) The needle thread trimming knife is dull.	• Grind the knife or replace it with a new one.
	13-2) The stroke of the needle thread trimming knife is incorrect.	• Check and adjust the stroke.
	13-3) The needle thread trimming knife does not catch needle thread.	• Adjust the installing position (clearance between needle and knife) of the knife.
	13-4) The last stitch has skipped.	• Refer to "1. Stitch skipping".
	13-5) Installing position of the knife is improper.	• Check and adjust the needle thread trimming knife and the thread separating position.
	13-6) Thread does not reach the blade point. (Clearance between the knife and needle is large.)	• Approach the knife to the needle. (Adjustment)
14. Looper thread cannot be trimmed. • S/R types only • J/C types only	14-1) The knife is dull.	• Grind the knife or replace it with a new one.
	14-2) The stroke of the moving blade is incorrect.	• Check and adjust the stroke.
	14-3) Contact of the moving knife and the counter knife is improper.	• Check and adjust the tilt of the counter knife.
	14-4) Installing position of the thread separating plate is incorrect.	• Check and adjust the needle thread trimming knife and the thread separating position.
	14-5) The knife pressure is insufficient.	• Adjust the knife pressure.
15. The cloth cannot be cut sharply.	15-1) Doubling the planes of the knife and the knife holder is incorrect.	• Correct the surface of the knife holder with oil stone or the like. When replacing knife/knife holder, be sure to use it after correcting the tilt.
	15-2) The knife is dull.	• Grind the knife or replace it with a new one.
	15-3) Knife pressing amount (knife pressure) is insufficient.	• Re-set the pressing amount (knife pressure).
	15-4) Chip has collected.	• Remove the chip.
	15-5) Knife pressure is too high and the knife blade has broken.	• Set proper knife pressure to each sewing product after replacing the knife.
16. Looper breakage	16-1) The clearance between the needle and the looper varies according to the angle (0°, 90° and 180°).	• Adjust the center of the needle.
	16-2) The clearance between the needle and the needle guard is too large or the needle and the needle guard come in excessive contact with each other.	• Check and adjust the clearance.
	16-3) The needle does not fit the kind of throat plate (needle size used).	• Use the throat plate suitable for the needle.

A blank page with rounded corners and horizontal ruling lines. The page is oriented vertically and contains 20 horizontal lines spaced evenly down the page. The top and bottom corners are rounded, while the sides are straight.

13. AIR PIPING DIAGRAM

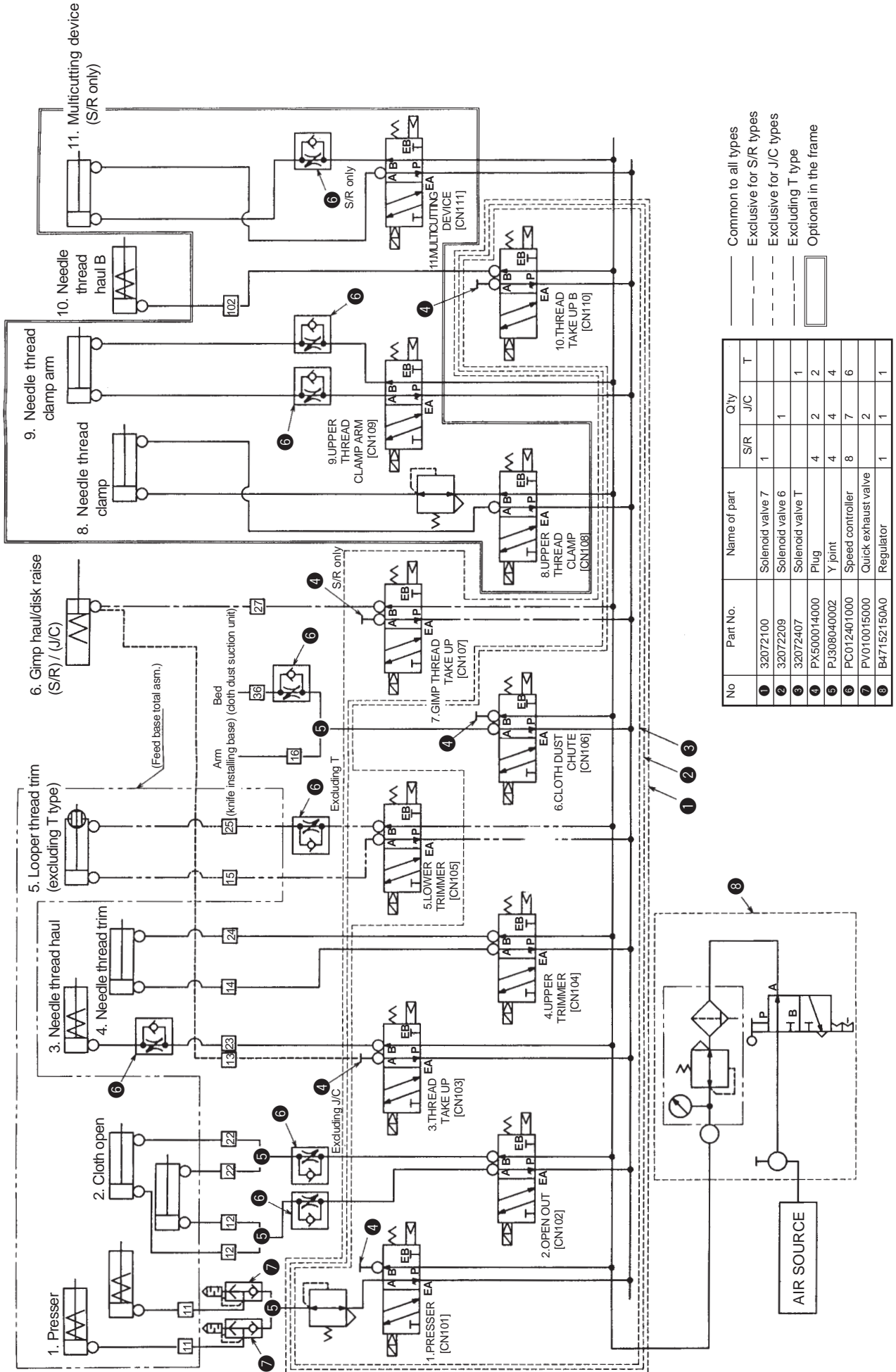

14. CIRCUIT DIAGRAM

(1) Connector circuit board wiring diagram

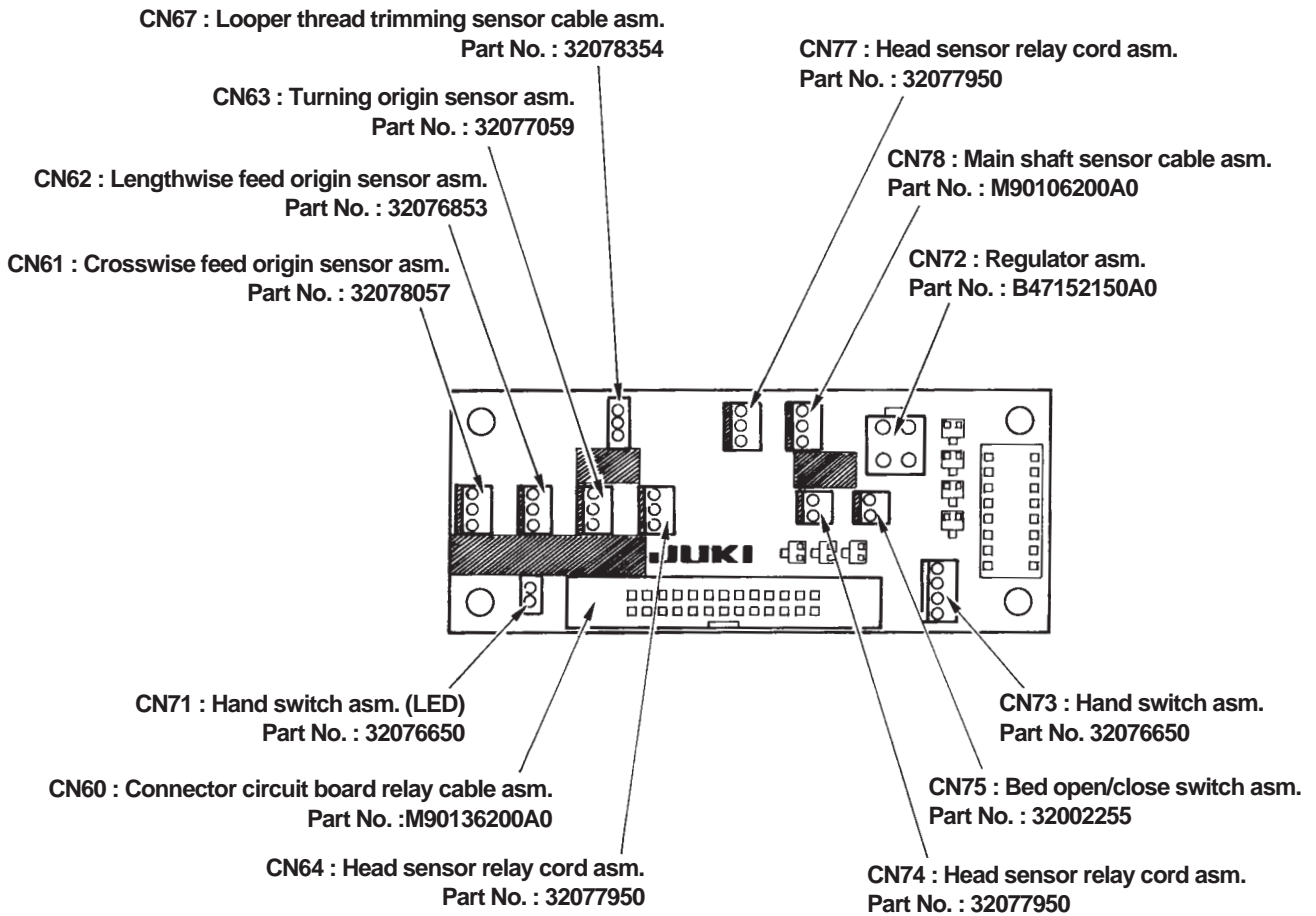

(2) Main circuit board wiring diagram

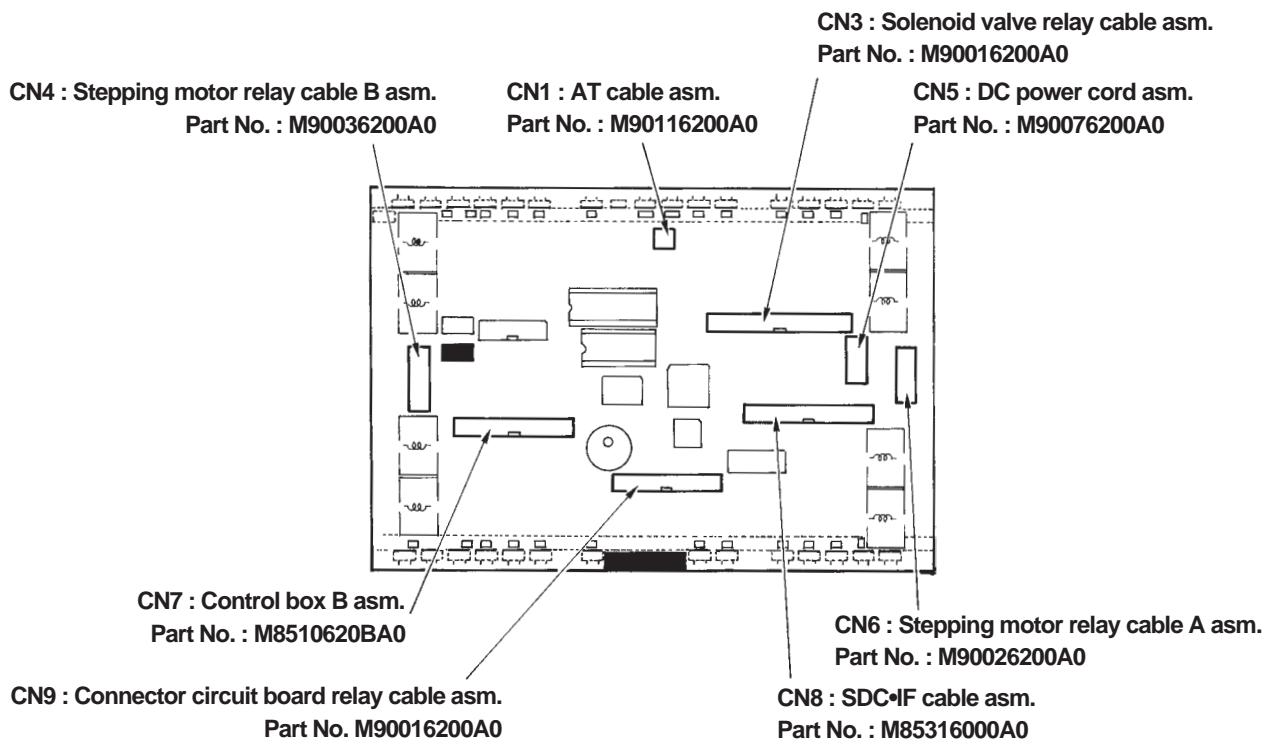

(3) Block diagram (1) 1 / 2

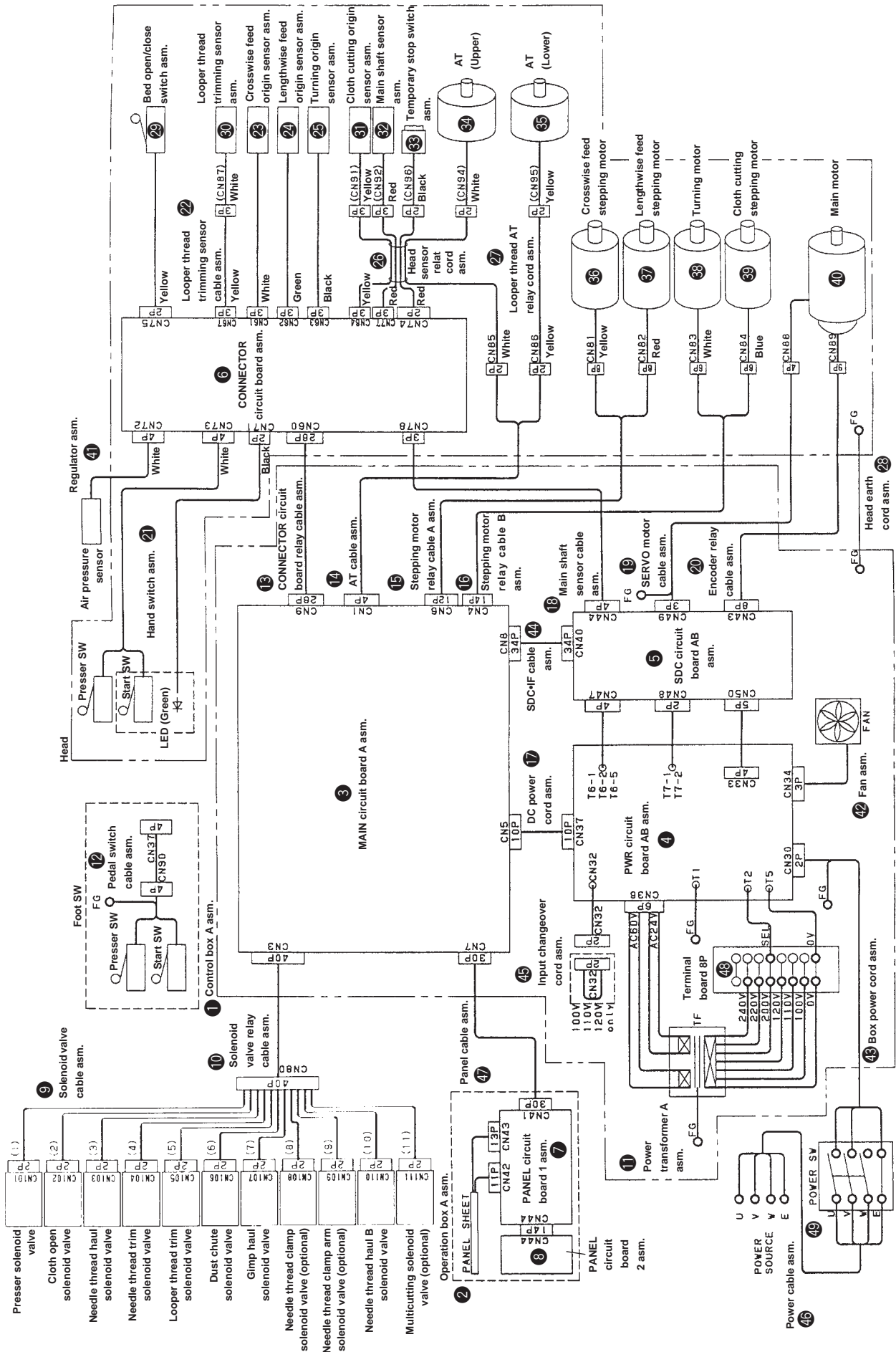

(3) Block diagram (1) 2 / 2

No.	Part No.	Description	Remarks
①	M8501620AA0	Control box A asm.	
②	M8510620AA0	Operation box A asm.	
③	M8601620AA0	MAIN circuit board A asm.	
④	M8620600AAB	PWR circuit board AB asm.	
⑤	M8610610AAB	SDC circuit board AB asm.	
⑥	M86026200A0	CONNECTOR circuit board asm.	
⑦	M86036200A0	PANEL circuit board 1 asm.	
⑧	M86046200A0	PANEL circuit board 2 asm.	
⑨	M90156200A0	Solenoid valve cable asm.	
⑩	M90016200A0	Solenoid valve relay cable asm.	
⑪	M8901620AA0	Power transformer A asm.	
⑫	M90146200A0	Pedal switch cable asm.	
⑬	M90136200A0	CONNECTOR circuit board relay cable asm.	
⑭	M90116200A0	AT cable asm.	
⑮	M90026200A0	Stepping motor relay cable A asm.	
⑯	M90036200A0	Stepping motor relay cable B asm.	
⑰	M90076200A0	DC power cord asm.	
⑱	M90106200A0	Main shaft sensor cable asm.	
⑲	M90046200A0	SERVO motor cable asm.	
⑳	M90056200A0	Encoder relay cable asm.	
㉑	32076655	Hand switch asm.	
㉒	32078654	Looper thread trimming sensor cable asm.	
㉓	32078057	Crosswise feed origin sensor asm.	
㉔	32076853	Lengthwise feed origin sensor asm.	
㉕	32077059	Turning origin sensor asm.	
㉖	32077950	Head sensor relay cord asm.	
㉗	32053357	Looper thread AT relay cord asm.	
㉘	M90206200A0	Head earth cord asm.	
㉙	32002255	Bed open/close switch asm.	
㉚	32017451	Looper thread trimming sensor asm.	
㉛	32077356	Cloth cutting origin sensor asm.	
㉜	32077653	Main shaft sensor asm.	
㉝	32002354	Temporary stop switch asm.	
㉞	32054900	AT (Upper)	
㉟	32053209	AT (Lower)	
㊱	KM000000320	Crosswise feed stepping motor	
㊲	KM000000310	Lengthwise feed stepping motor	
㊳	KM000000330	Turning motor	
㊴	KM000000300	Cloth cutting stepping motor	
㊵	KM000000340	Main motor	
㊶	B47152150A0	Regulator asm.	
㊷	M85405900A0	Fan asm.	
㊸	M85216000A0	Box power cord asm.	
㊹	M85316000A0	SDC•IF cable asm.	
㊺	M85236000A0	Input changeover cord asm.	
㊻	M90175800A0	Power cable asm.	
㊼	M85020600A0	Panel cable asm.	
㊽	HK026650080	Terminal board 8P	
㊾	HA004250000	Power switch	

(4) Block diagram (2) 1 / 2

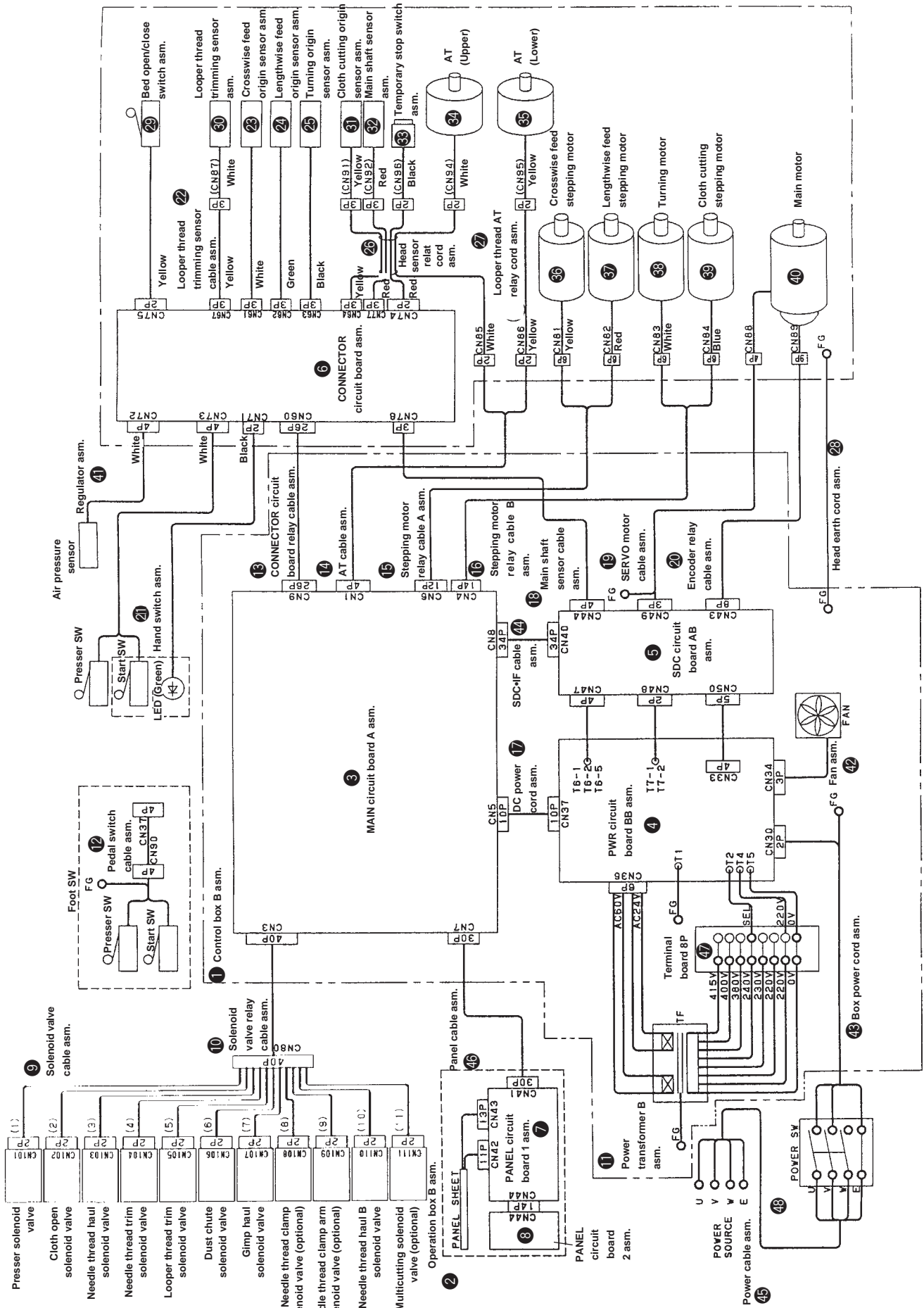

(4) Block diagram (2) 2 / 2

No.	Part No.	Description	Remarks
①	M8501620BA0	Control box B asm.	
②	M8510620BA0	Operation box B asm.	
③	M8601620AA0	MAIN circuit board A asm.	
④	M8620600BAB	PWR circuit board BB asm.	
⑤	M8610610AAB	SDC circuit board AB asm.	
⑥	M86026200A0	CONNECTOR circuit board asm.	
⑦	M86036200A0	PANEL circuit board 1 asm.	
⑧	M86046200A0	PANEL circuit board 2 asm.	
⑨	M90156200A0	Solenoid valve cable asm.	
⑩	M90016200A0	Solenoid valve relay cable asm.	
⑪	M8901620BA0	Power transformer B asm.	
⑫	M90146200A0	Pedal switch cable asm.	
⑬	M90136200A0	CONNECTOR circuit board relay cable asm.	
⑭	M90116200A0	AT cable asm.	
⑮	M90026200A0	Stepping motor relay cable A asm.	
⑯	M90036200A0	Stepping motor relay cable B asm.	
⑰	M90076200A0	DC power cord asm.	
⑱	M90106200A0	Main shaft sensor cable asm.	
⑲	M90046200A0	SERVO motor cable asm.	
⑳	M90056200A0	Encoder relay cable asm.	
㉑	32076655	Hand switch asm.	
㉒	32078354	Looper thread trimming sensor cable asm.	
㉓	32078057	Crosswise feed origin sensor asm.	
㉔	32076853	Lengthwise feed origin sensor asm.	
㉕	32077059	Turning origin sensor asm.	
㉖	32077950	Head sensor relay cord asm.	
㉗	32053357	Looper thread AT relay cord asm.	
㉘	M90206200A0	Head earth cord asm.	
㉙	32002255	Bed open/close switch asm.	
㉚	32017451	Looper thread trimming sensor asm.	
㉛	32077356	Cloth cutting origin sensor asm.	
㉜	32077653	Main shaft sensor asm.	
㉝	32002354	Temporary stop switch asm.	
㉞	32054900	AT (Upper)	
㉟	32053209	AT (Lower)	
㊱	KM000000320	Crosswise feed stepping motor	
㊲	KM000000310	Lengthwise feed stepping motor	
㊳	KM000000330	Turning motor	
㊴	KM000000300	Cloth cutting stepping motor	
㊵	KM000000340	Main motor	
㊶	B47152150A0	Regulator asm.	
㊷	M85405900A0	Fan asm.	
㊸	M85226000A0	Box power cord asm.	
㊹	M85316000A0	SDC•IF cable asm.	
㊺	M90175800A0	Power cable asm.	
㊻	M85020600A0	Panel cable asm.	
㊼	HK054250040	Terminal board 4P	2 pcs. used
㊽	HA004250000	Power switch	

(5) Block diagram (3) 1 / 2

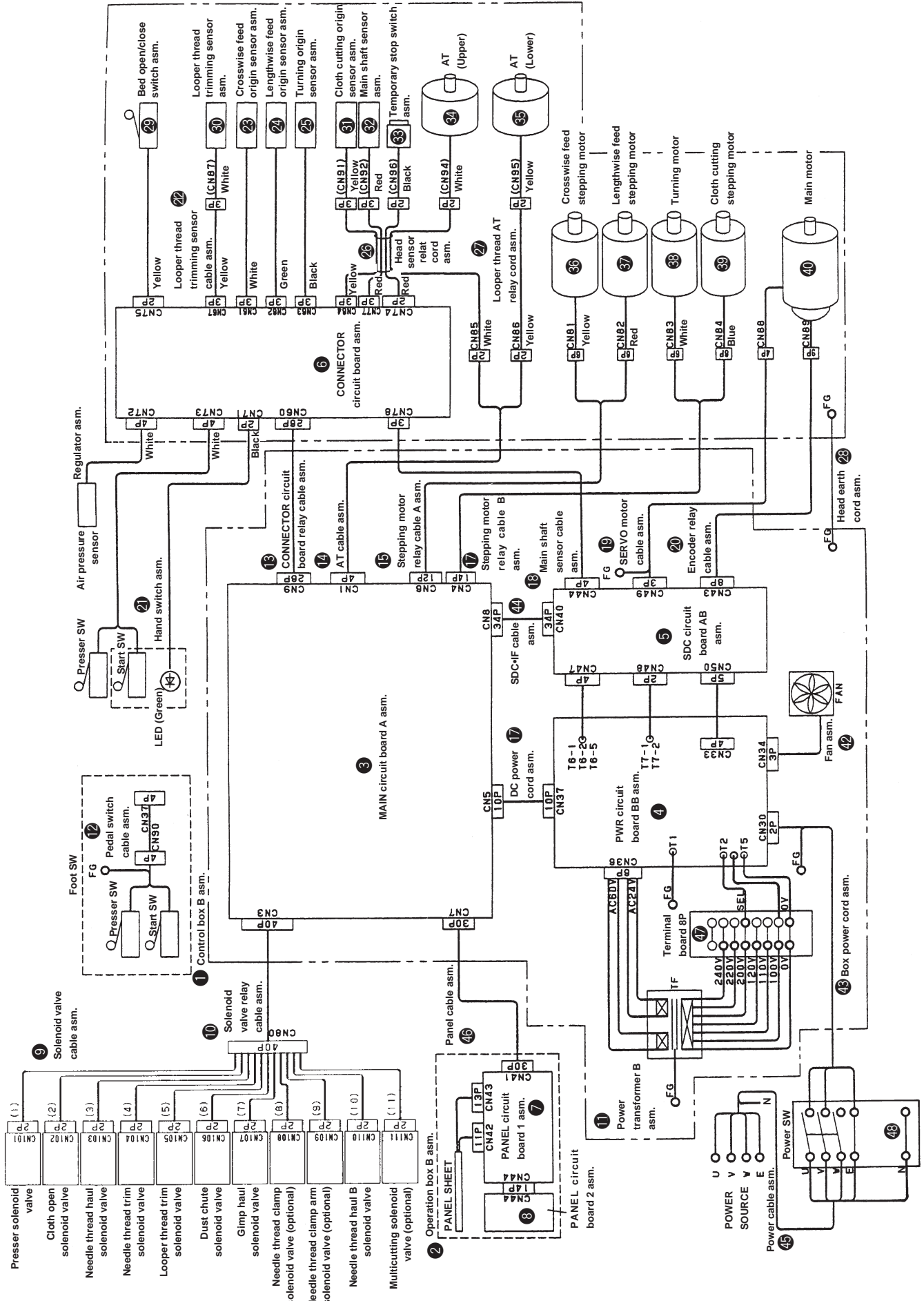

(5) Block diagram (3) 2 / 2

No.	Part No.	Description	Remarks
①	M8501620CA0	Control box C asm.	
②	M8510620BA0	Operation box B asm.	
③	M8601620AA0	MAIN circuit board A asm.	
④	M8620600BAB	PWR circuit board BB asm.	
⑤	M8610610AAB	SDC circuit board AB asm.	
⑥	M86026200A0	CONNECTOR circuit board asm.	
⑦	M86036200A0	PANEL circuit board 1 asm.	
⑧	M86046200A0	PANEL circuit board 2 asm.	
⑨	M90156200A0	Solenoid valve cable asm.	
⑩	M90016200A0	Solenoid valve relay cable asm.	
⑪	M8901620BA0	Power transformer B asm.	
⑫	M90146200A0	Pedal switch cable asm.	
⑬	M90136200A0	CONNECTOR circuit board relay cable asm.	
⑭	M90116200A0	AT cable asm.	
⑮	M90026200A0	Stepping motor relay cable A asm.	
⑯	M90036200A0	Stepping motor relay cable B asm.	
⑰	M90076200A0	DC power cord asm.	
⑱	M90106200A0	Main shaft sensor cable asm.	
⑲	M90046200A0	SERVO motor cable asm.	
⑳	M90056200A0	Encoder relay cable asm.	
㉑	32076655	Hand switch asm.	
㉒	32078354	Looper thread trimming sensor cable asm.	
㉓	32078057	Crosswise feed origin sensor asm.	
㉔	32076853	Lengthwise feed origin sensor asm.	
㉕	32077059	Turning origin sensor asm.	
㉖	32077950	Head sensor relay cord asm.	
㉗	32053357	Looper thread AT relay cord asm.	
㉘	M90206200A0	Head earth cord asm.	
㉙	32002255	Bed open/close switch asm.	
㉚	32017451	Looper thread trimming sensor asm.	
㉛	32077356	Cloth cutting origin sensor asm.	
㉜	32077653	Main shaft sensor asm.	
㉝	32002354	Temporary stop switch asm.	
㉞	32054900	AT (Upper)	
㉟	32053209	AT (Lower)	
㊱	KM000000320	Crosswise feed stepping motor	
㊲	KM000000310	Lengthwise feed stepping motor	
㊳	KM000000330	Turning motor	
㊴	KM000000300	Cloth cutting stepping motor	
㊵	KM000000340	Main motor	
㊶	B47152150A0	Regulator asm.	
㊷	M85405900A0	Fan asm.	
㊸	M85226000A0	Box power cord asm.	
㊹	M85316000A0	SDC•IF cable asm.	
㊺	M90285800A0	Power cable asm.	
㊻	M85020600A0	Panel cable asm.	
㊼	HK054250040	Terminal board 4P	2 pcs. used
㊽	HA00303000A	Power switch	

(6) Stepping motor circuit diagram

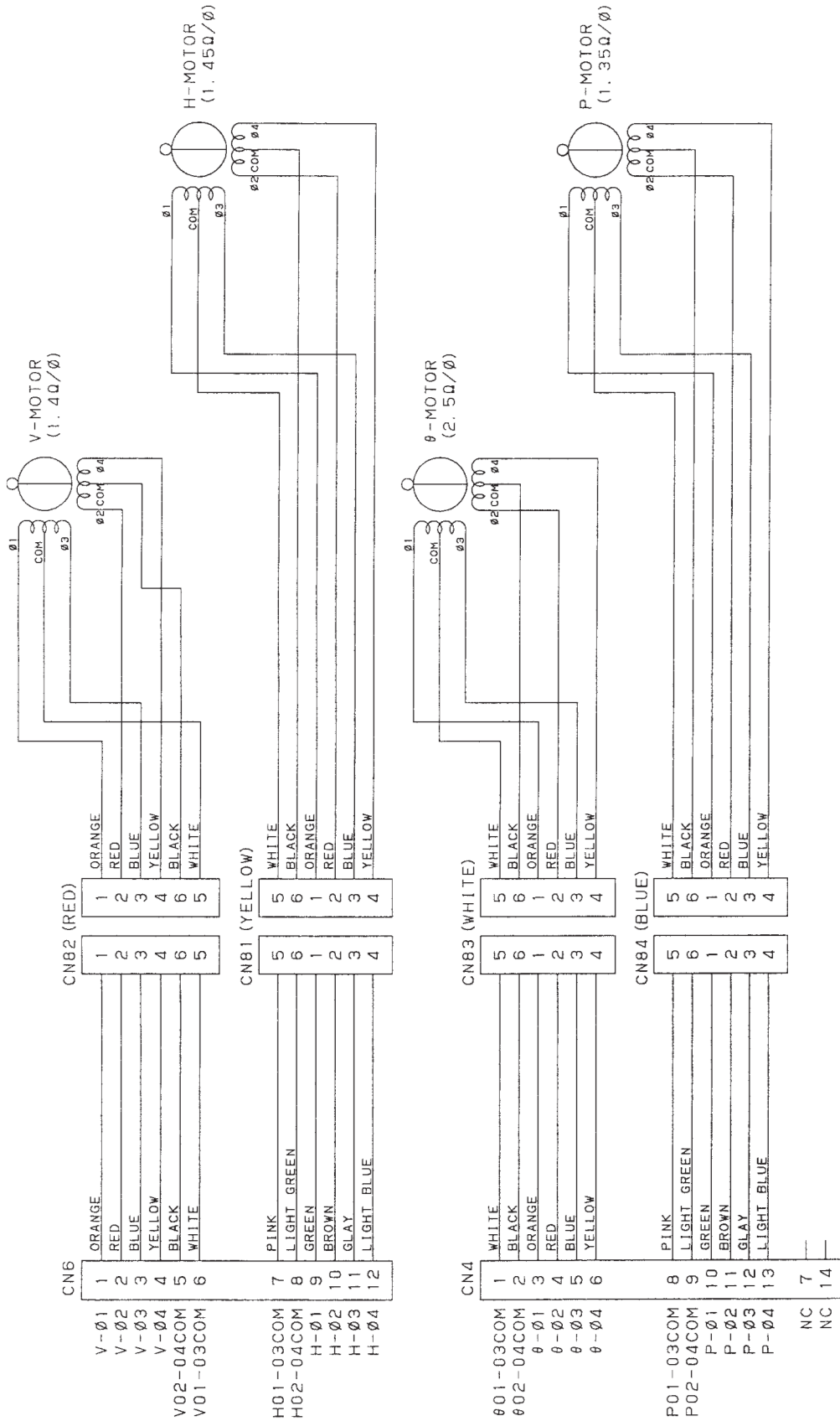

(7) Sensor circuit diagram

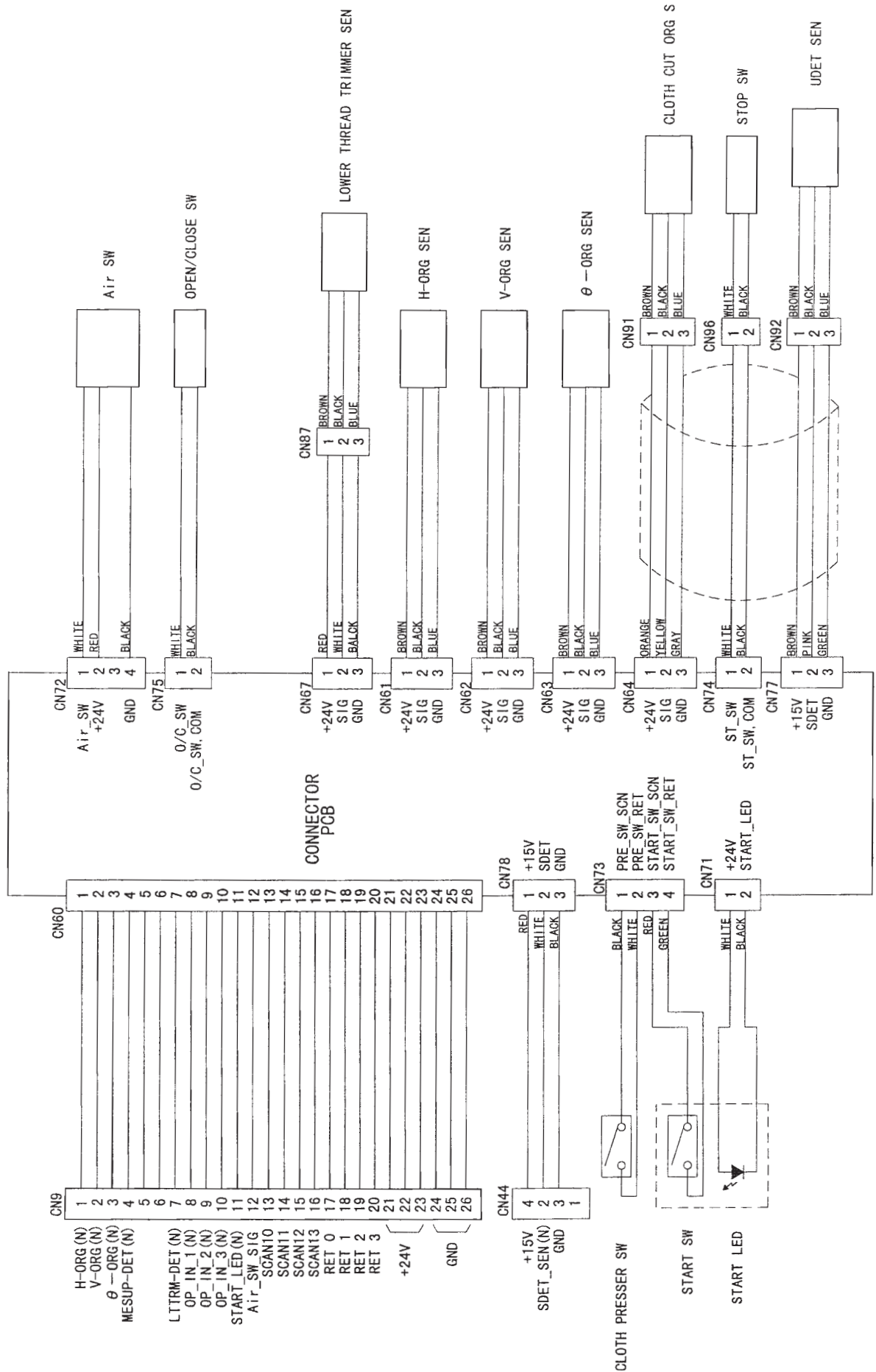

(8) Power source circuit diagram 100V, 200V

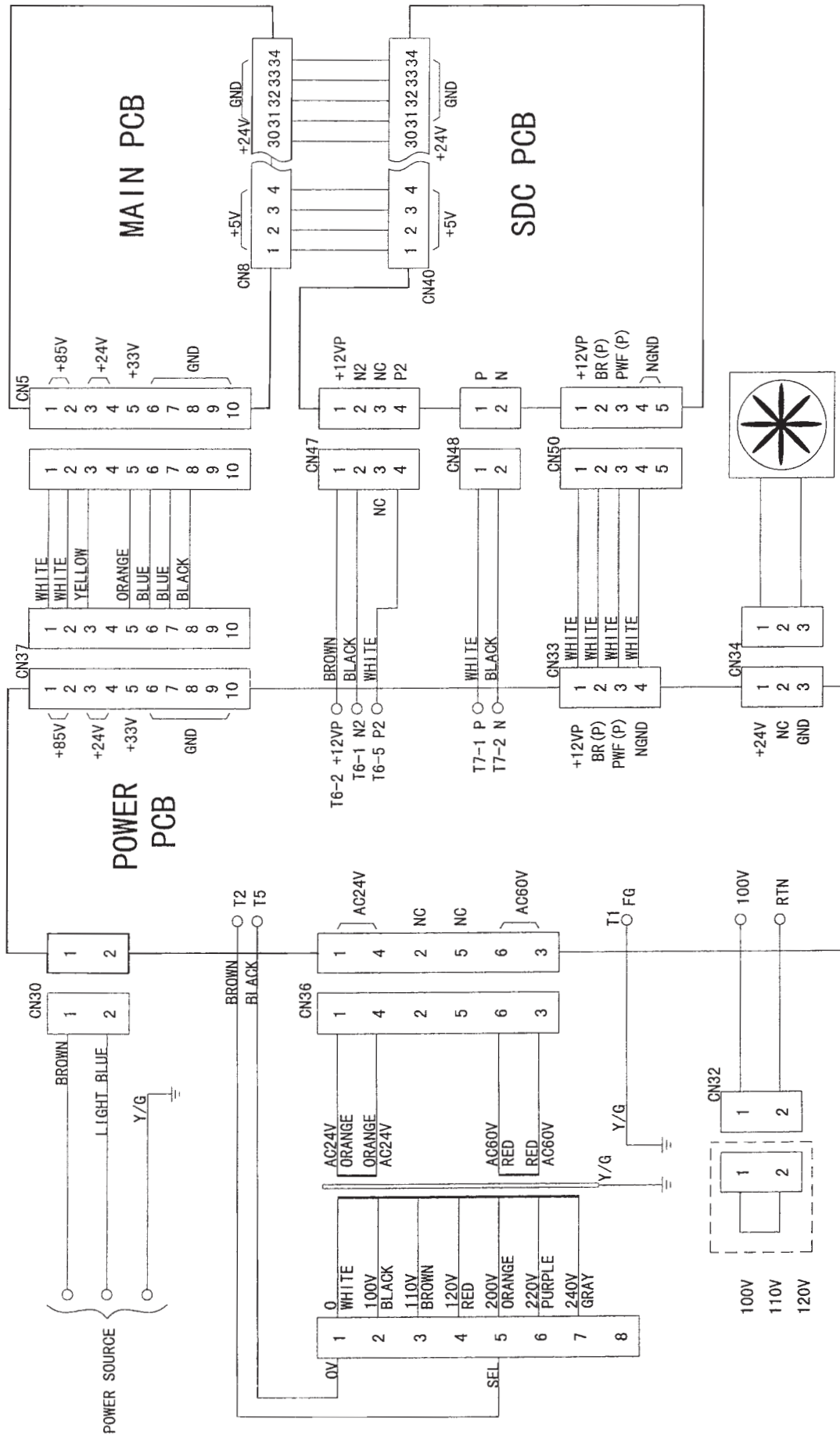

(9) Power source circuit diagram 380V

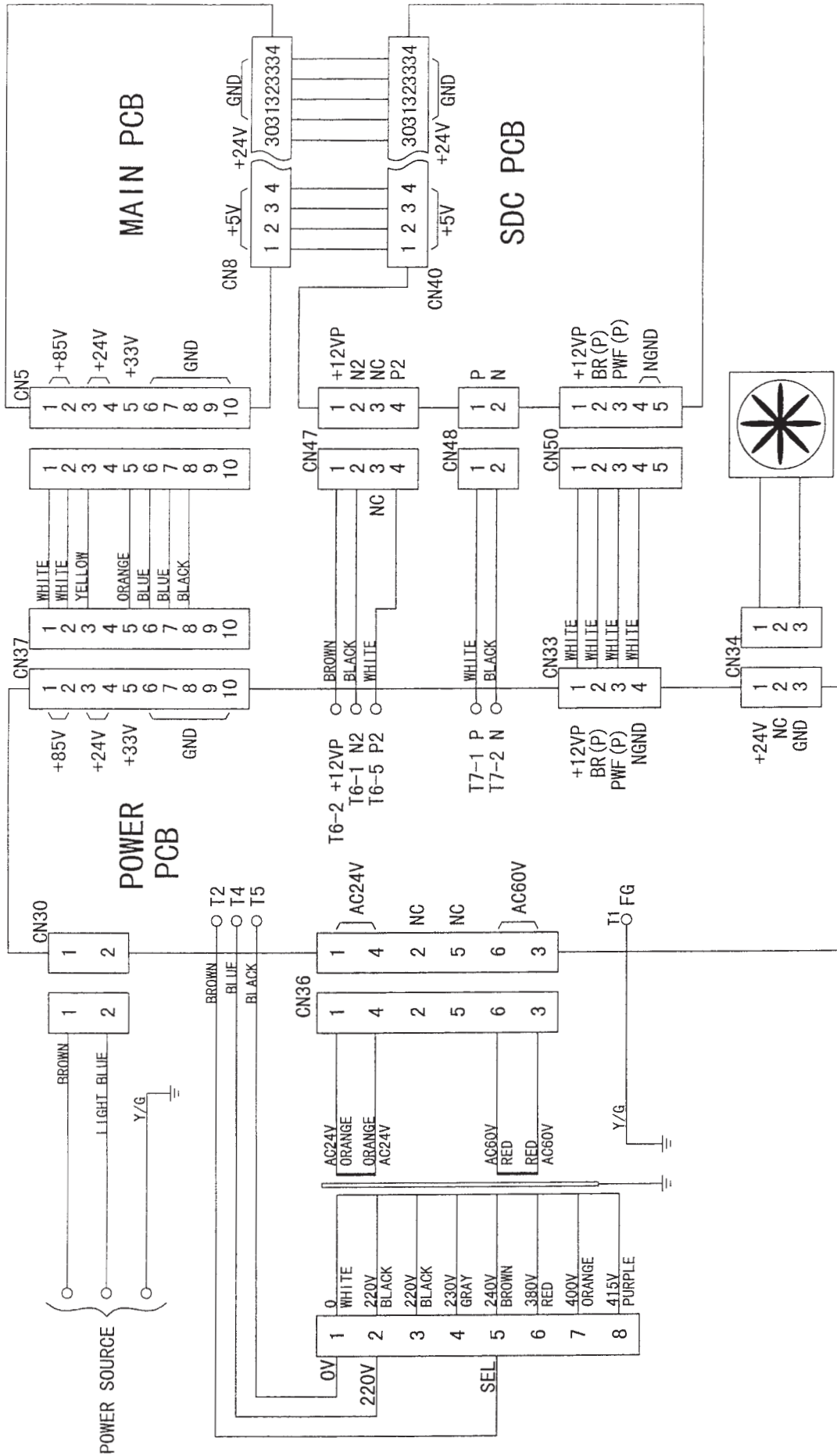

(10) Solenoid valve circuit diagram

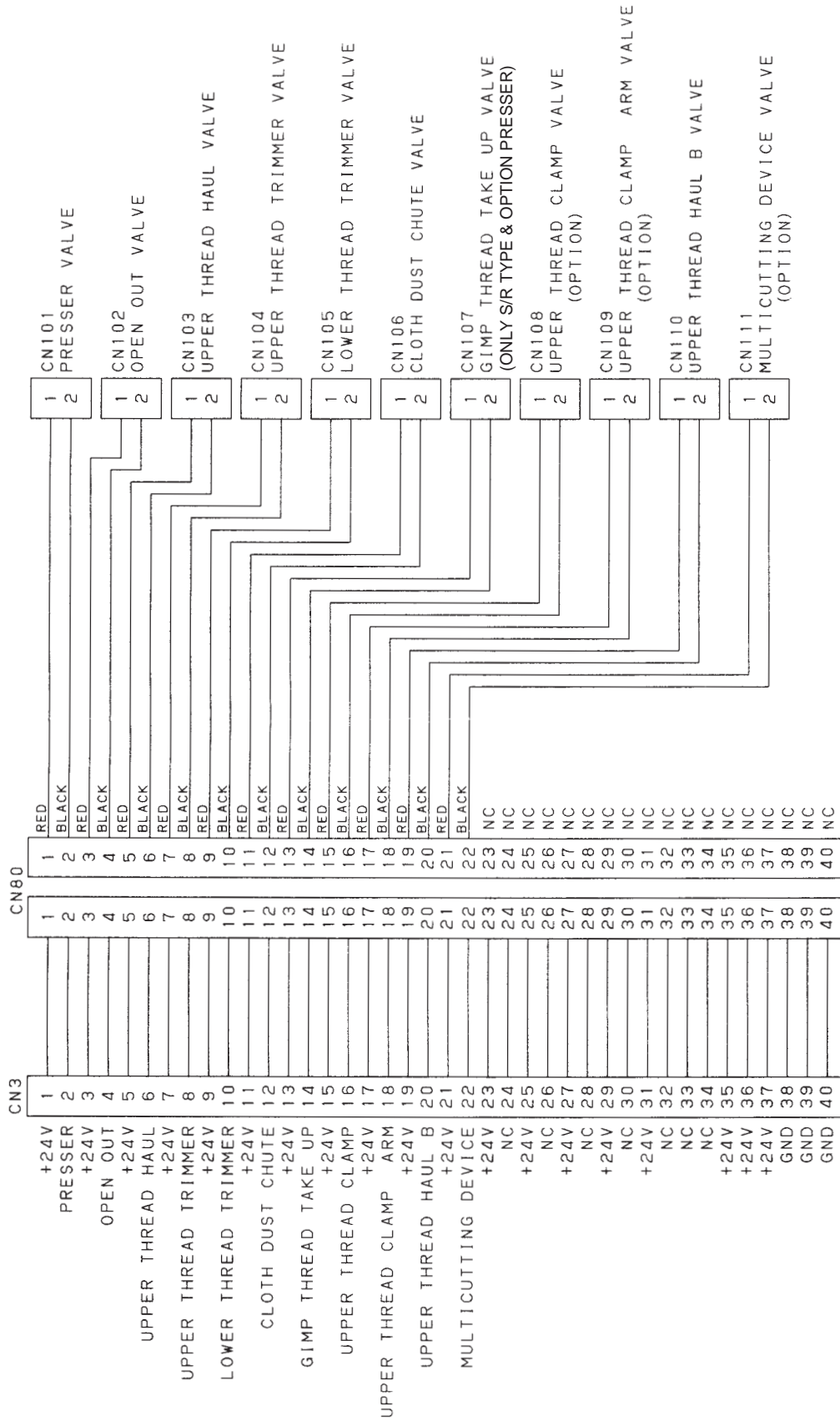

(11) Active tension curcuit diagram

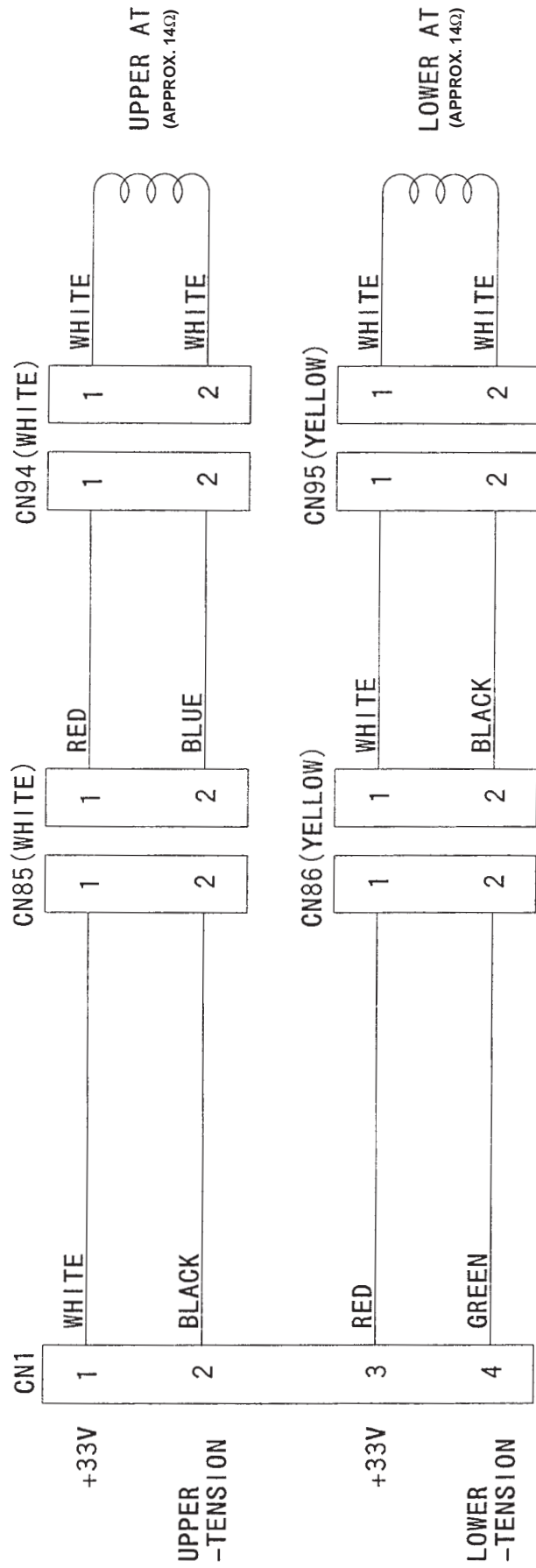

(12) Servo motor circuit diagram

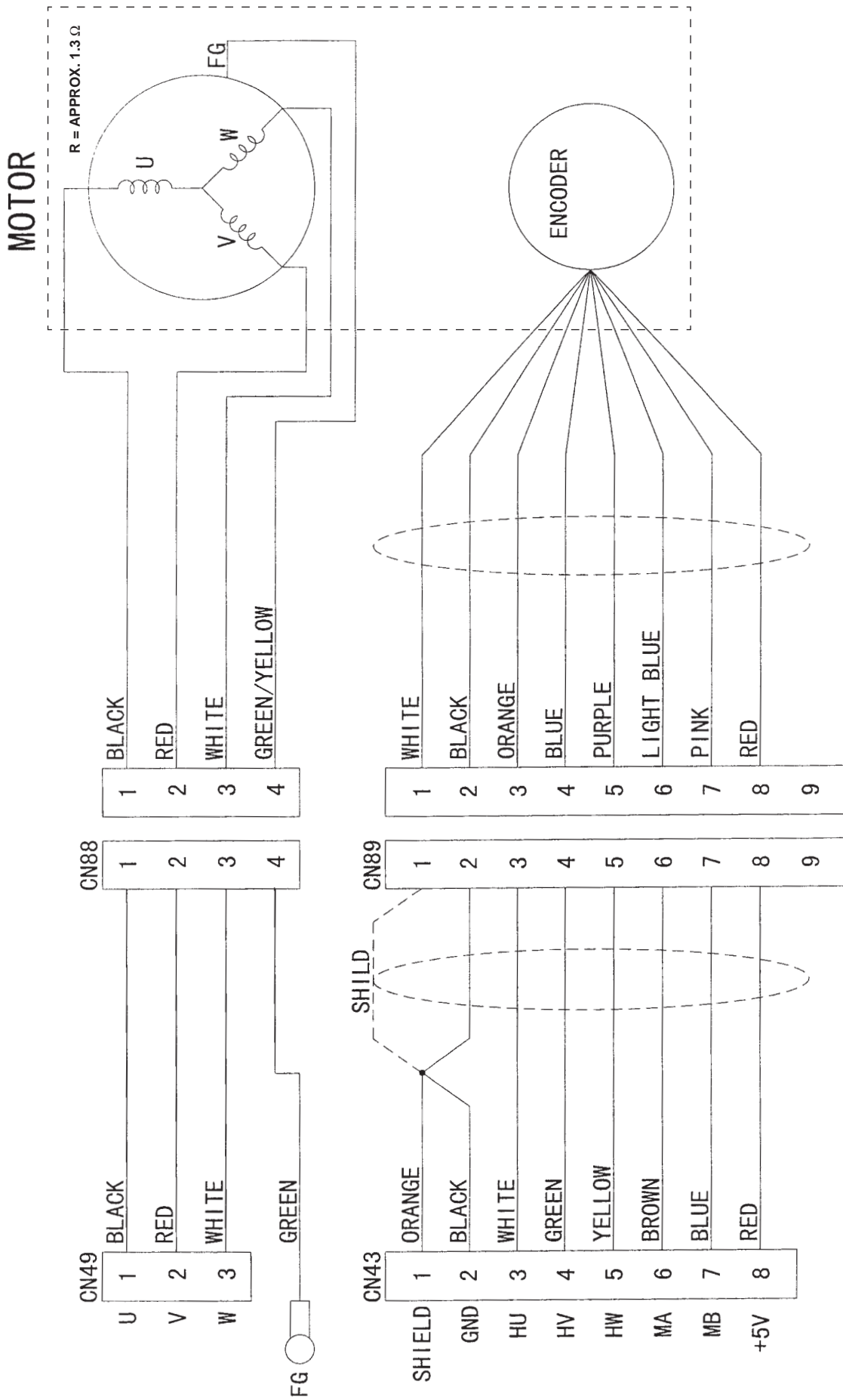

15. MULTICUTTING DEVICE

CONTENTS

(1) SPECIFICATIONS	136
(2) INSTALLING THE MULTICUTTING DEVICE	138
1) Removing the cloth cutting knife base	138
2) Installing the cloth chip suction device asm.	138
3) Installing the cloth cutting knife base A asm.	140
4) Changing the position of the knife stopper	142
(3) CONNECTING THE PNEUMATIC COMPONENTS	144
1) Piping the knife base cylinder	144
2) Piping the cloth chip suction device	146
(4) ADJUSTING THE MULTICUTTING DEVICE	148
1) Adjusting the knife	148
① Adjusting the longitudinal position of the cloth cutting knife	148
② Adjusting the lateral position of the cloth cutting knife	148
③ Adjusting the inclination of the cloth cutting knife	150
2) Timing between the needle and the looper	150
① Adjusting the inclination of the cloth cutting knife (eyelet)	150
② Adjusting the lateral position of knife holder	152
(5) ADJUSTING THE PNEUMATIC COMPONENTS	154
1) Adjusting the speed controller	154
(6) SETTING THE DIP SWITCH	154
(7) REPLACING THE CLOTH CUTTING KNIFE	156
1) Replacing the cloth cutting knife (eyelet)	156
2) Replacing the cloth cutting knife (straight)	156
(8) ADJUSTING THE CLOTH CUTTING KNIFE PRESSURE	158
1) Adjusting the knife pressing amount	158
(9) SETTING THE PATTERN DATA	160
1) Setting the knife No.	160
2) Cut length compensation	160
3) Plural times selection	162
4) Decorative buttonhole offset	164
(10) MEMORY SWITCH	164
(11) REPLACEMENT GAUGE	168

15. MULTICUTTING DEVICE

(1) Specifications

Specifications	SS M type
Application	Men's and ladies' wear
Sewing speed	400 to 2,200 rpm (adjustable in 100 rpm steps)
Stitch length (Cautions 1 and 2)	10 to 38 mm (with looper thread trimmer) 10 to 50 mm (in case of removing looper thread trimming device)
Stitch bite width (Cautions 3 and 4)	2.0 to 3.2 mm
Taper bar length	0 mm, 3 to 15 mm
Lift of presser foot	13 mm (Max. 16 mm)
Method of changing sewing shape	Program selection method
Buttonhole cutting system (Caution 5)	Cut-before knife, cut-after knife, without knife
Feed system	Intermittent feed by stepping motor
Cloth cutting drive	Vertical drive by stepping motor
Needle (Caution 3)	DO x 558 #90 to 110
Safety device	Temporary stop switch and automatic stop function at the time of detection of trouble
Lubricating oil	JUKI New Defrix Oil No. 2 (Equivalent to ISO VG32)
Air pressure	0.49 Mpa
Air consumption	6 ℓ /min (8-cycle/min)
Noise level	81.5 dB/max. speed 2,200 rpm
Dimensions	1,060 mm (W) x 790 mm (L) x 1,230 mm (H) (Excluding thread stand)
Power consumption	550 VA
Gross weight	185 kg

Caution 1. Stitch length becomes as follows in accordance with the knife holder.

With looper thread trimmer (Memory switch No. 22 = 1)

Part No.	Knife holder length (mm)	Max. stitch length		Min. stitch length		Shape knife holder
		Eyelet buttonhole (mm)	Decorative buttonhole (mm)	Eyelet buttonhole (mm)	Decorative buttonhole (mm)	
32087801 *	18	38 (*)	38 (*)	18	10	Without step
32087702	26	38 (*)	38 (*)	26	16	
32087603	32	38 (*)	38 (*)	32	22	
32088106	18	38 (*)	38 (*)	10	10	With step
32088007	26	38 (*)	38 (*)	16	16	
32087900	32	38 (*)	38 (*)	22	22	

* : Provided as standard

(*) : When stitch length exceeds 32 mm at the time of straight bartacking and round bartacking, defective clamping or defective cutting of looper thread, and gimp may occur.

Without looper thread trimmer (Memory switch No. 22 = 0)

Knife holder length (mm)	Max. stitch length	
	Eyelet buttonhole (mm)	Decorative buttonhole (mm)
18	38	38
26	46	46
32	50	50

* Min. stitch length is the same as that with looper thread trimmer.

Caution 2. Be sure to use the knife holders exclusive for the multicutting device (32087801, 32087702, 32087603, 32088106, 32088007 and 32087900).

In addition, be careful of the clearances between the knife holder and the right/left presser feet. (The knife holder may come in contact with the presser holding plate at the time of cloth cutting.)

Caution 3. Stitch bite width and needle No. are set as follows at the time of delivery from the factory.

Stitch bite width : 2.8 mm

Needle No. : #100

(When changing the stitch bite width or the needle No., make sure of the installing positions of needle and looper, and the spreaders, the timing to open/close the spreaders, and the clearance between the needle and the needle guard.)

Caution 4. The range of stitch bite width can be changed from 2.0 to 3.2 mm to 2.6 to 4.0 mm by changing the optional left looper and the optional left spreader.

Caution 5. When the cut-before knife is selected, the knife holder may come in contact with the presser and the presser holding plate if the clearances between the knife holder and the right/left presser feet are small.

Caution 6. When installing the multicutting device after set-up of the machine, replace the ROM with one described below. (Part No. : HL010523011, Rev : 011G)

(2) Installing the multicutting device

Standard Adjustment

1) Removing the cloth cutting knife base

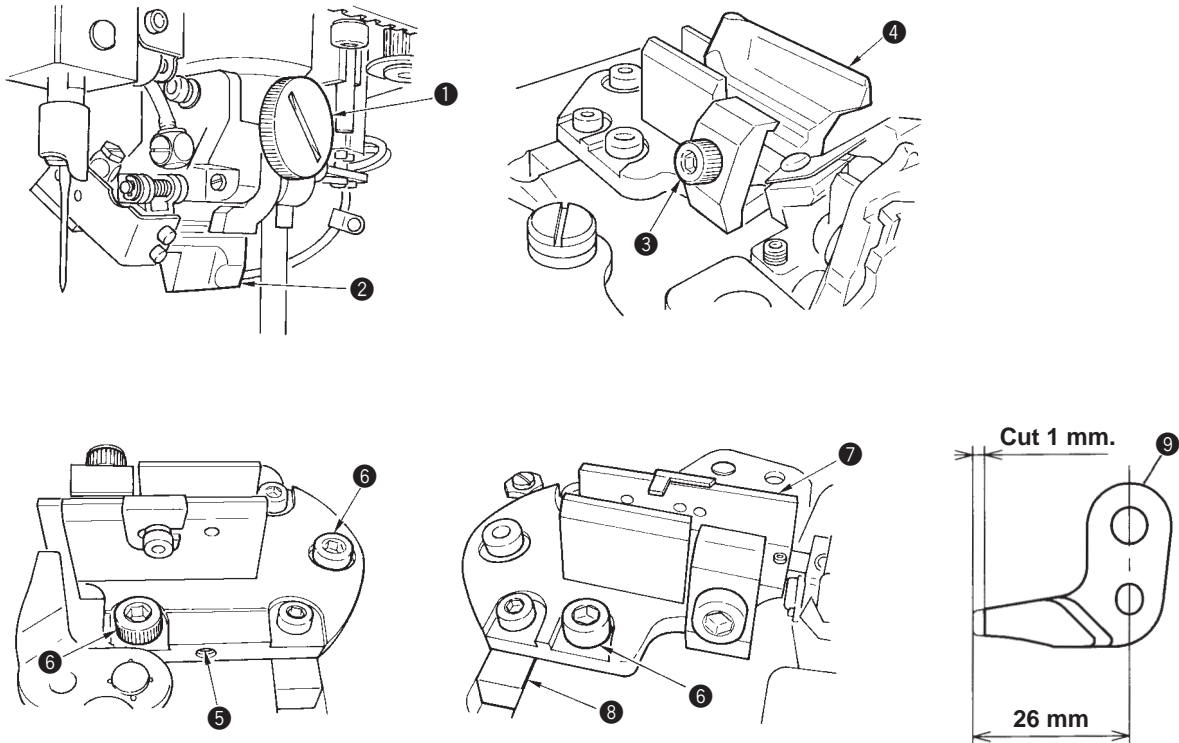

2) Installing the cloth chip suction device asm.

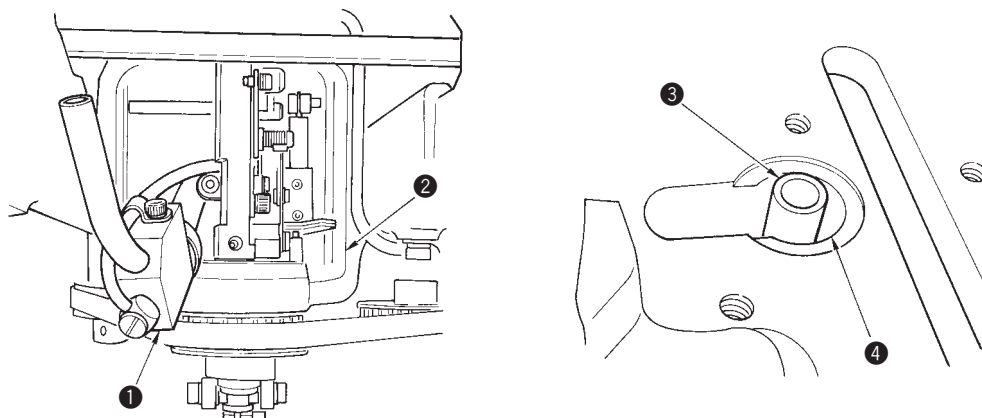

Adjustment Procedures	Results of Improper Adjustment
<p>1) Removing the cloth cutting knife base (Remove the hose of the cloth chip chute connected to the base.)</p> <p>* Check the base since there are a new and an old parts. Further, in case of the old part, replace it with a new part. Refer to “15 - (2) -4) Changing the position of the knife stopper”.</p> <ol style="list-style-type: none"> 1. Turn OFF the power and the air to the machine. 2. Loosen fixed screw ❶ and remove knife holder ❷. 3. Loosen setscrew ❸ and remove cloth cutting knife ❹. 4. Loosen setscrew ❺. 5. Remove three setscrews ❻ in the knife base and remove cloth cutting knife base ❼ (together with knife base key ❽) from the machine bed. (Remove the piping connected to the base as well.) 6. When the dimension, 26 mm of needle thread trimming vertical arm ❾ is longer, cut the top end by 1 mm. <p>(Caution) Three setscrews ❻ in the knife base are used again. Keep them without losing.</p>	
<p>2) Installing the cloth chip suction device asm.</p> <ol style="list-style-type: none"> 1. Remove the cloth chip chute hose from the bottom cover. 2. Insert cloth chip suction device asm. ❶ to machine bed ❷ and adjust so that cloth chip chute A ❸ appears from hole ❹ of the machine bed. (It is possible to insert it from the rear side.) [Pass the air tube (black) of the cloth chip suction device ❶ and the cloth chip hose (white) up to the rear side of the machine bed ❷.] 3. Attach the cloth chip chute hose of the cloth chip suction device asm. ❶ to the bottom cover after connecting with the cloth cutting knife base A. (When the diaphragm elbow [Part No. : PJ304120002] is assembled to the bottom cover, remove it and replace it with cloth chip bush [Part No. : 32006504].) 	

Standard Adjustment

3) Installing the cloth cutting knife base A asm.

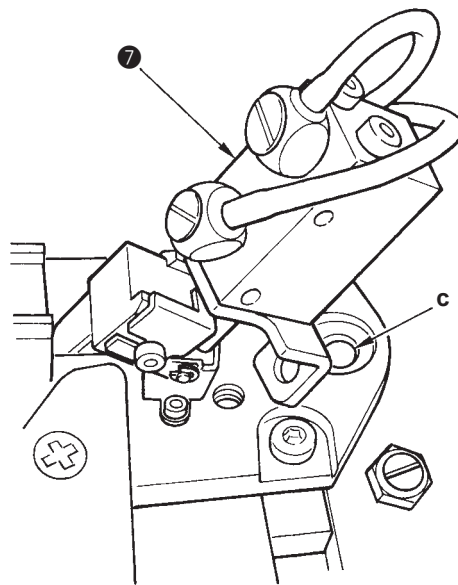
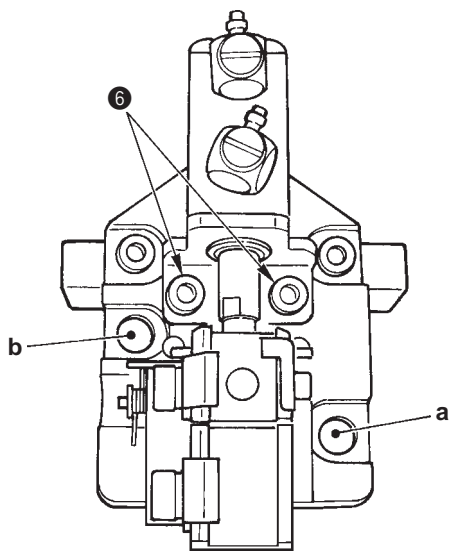
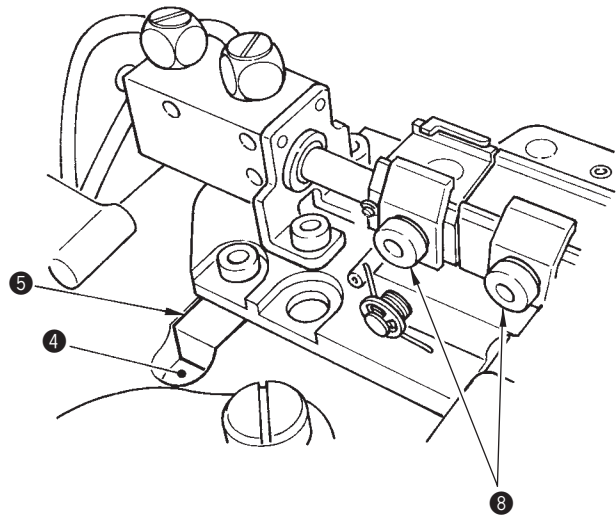
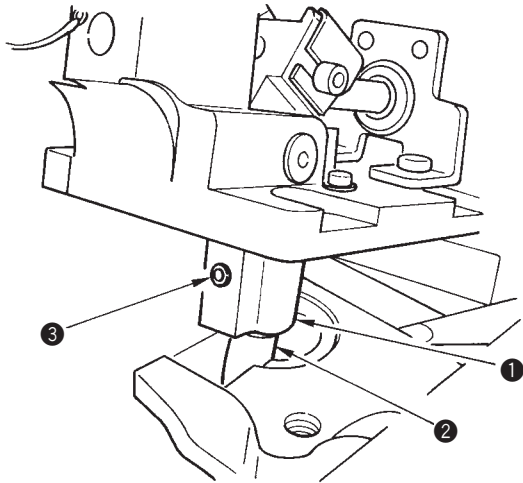

Adjustment Procedures	Results of Improper Adjustment
<p>3) Installing the cloth cutting knife base A asm.</p> <ol style="list-style-type: none"> 1. Loosen two setscrews ⑧ and remove cloth cutting knife (eyelet) and cloth cutting knife (straight) from the device. (Refer to “7. REPLACING THE CLOTH CUTTING KNIFE”.) 2. Insert cloth chip chute A ② into cloth chip chute boss ① and fix it with setscrew ③. <p>(Caution) Fix the cloth chip chute asm. so that it does not tilt.</p> <ol style="list-style-type: none"> 3. Put cloth cutting knife base key ⑤ in key slot ④ of the machine bed. 4. Put two setscrews in the knife base which have been removed in the process (4) - 1) in the mounting holes, a and b. Then fix them after checking the lateral position of the device “(4) - 1) Adjusting the knife dropping position”. 5. Remove two setscrews ⑥ and raise knife base cylinder ⑦. 6. Put a setscrew ⑧ in the knife base which has been removed in the process (4) - 1) in the mounting hole, c. Then fix it after checking “(4) - 1) Adjusting the knife dropping position”. 7. Return knife base cylinder ⑦ to its home position and fix it with two setscrews ⑥. 	

Standard Adjustment

4) Changing the position of the knife stopper

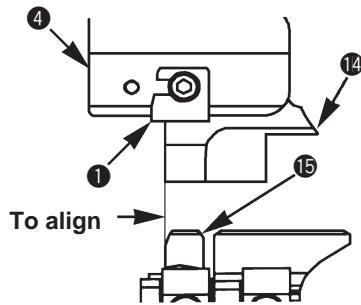
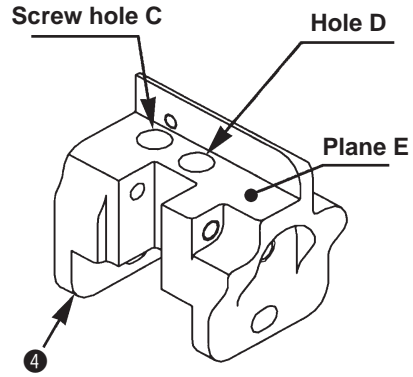
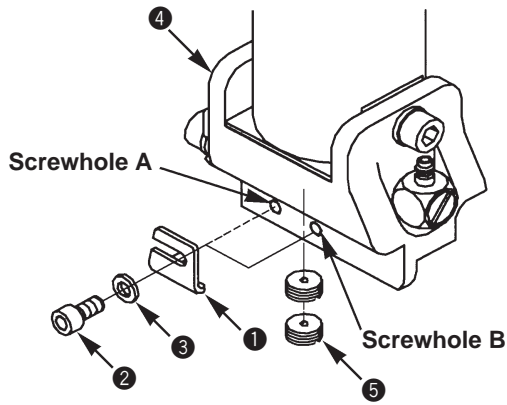

New parts

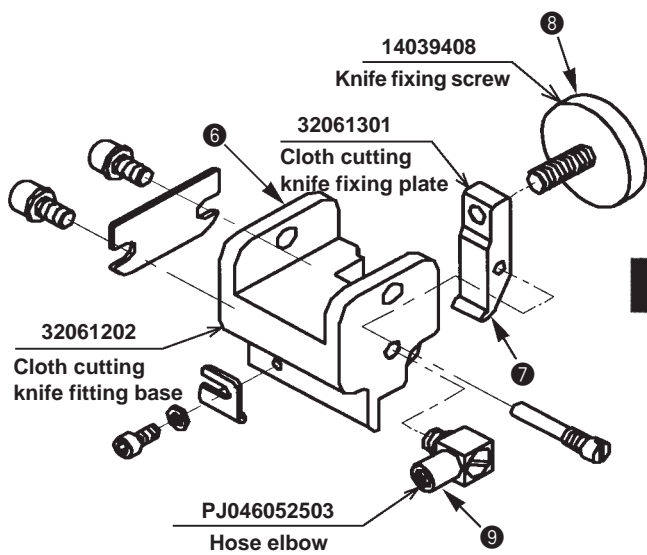

Old parts

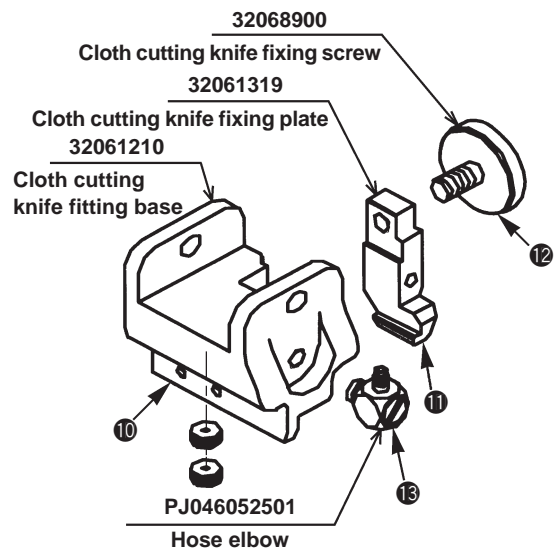

Adjustment Procedures	Results of Improper Adjustment
<p>4) Changing the position of the knife stopper</p> <ol style="list-style-type: none"> 1. Remove knife stopper ❶ of knife fitting base ❷, setscrew ❸ and washer ❹, and change from screw hole A to screw hole B. 2. Attach two stop plugs ❺ to screw hole C so that the stop plugs do not protrude from the knife fitting plane E. 3. Adjust the position of knife stopper ❶ so that the back of cloth cutting knife (eyelet) ❻ and that of knife holder ❼ align with each other. <p>(Caution) When old parts below (❹, ❺, ❻ and ❼) are assembled into the sewing machine, replace all of them with new parts (❽, ❾, ❿ and ⓫). (Assemble the other old parts in the illustration into new parts without replacing them.)</p>	

(3) Connecting the pneumatic components

Standard Adjustment

1) Piping the knife base cylinder

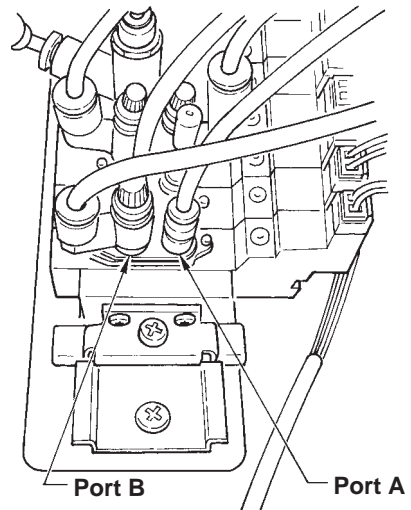
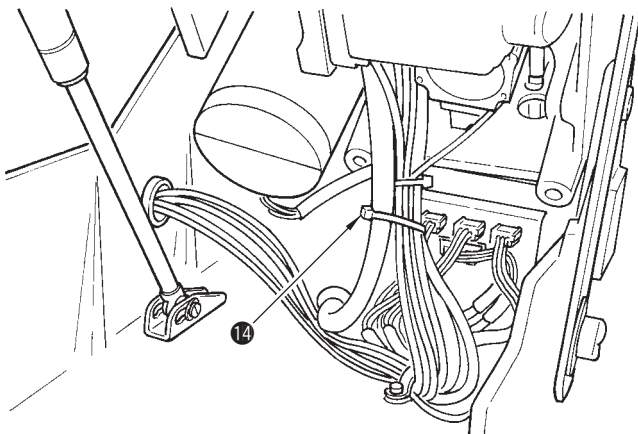
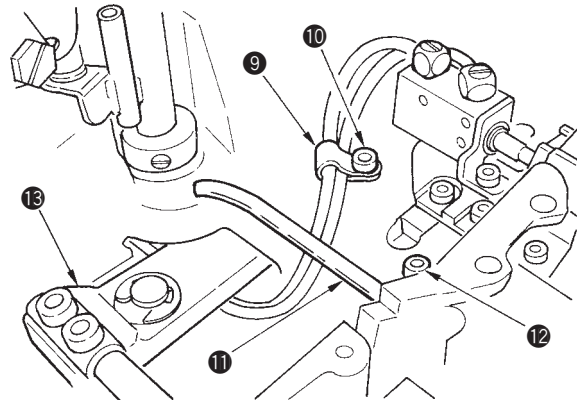
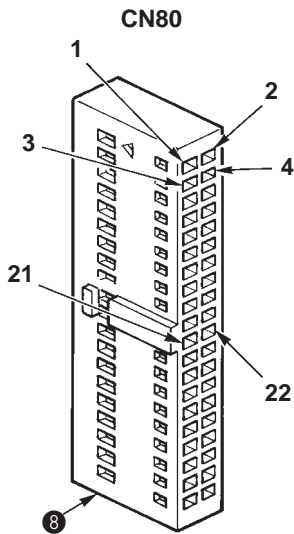
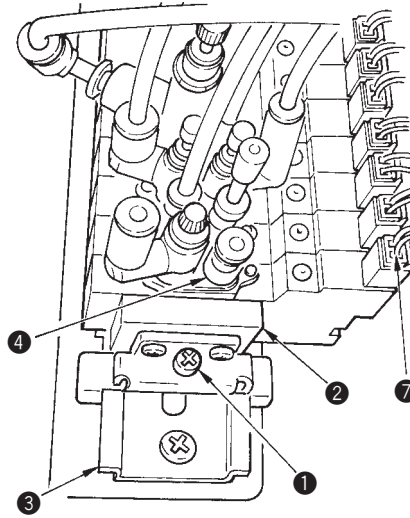
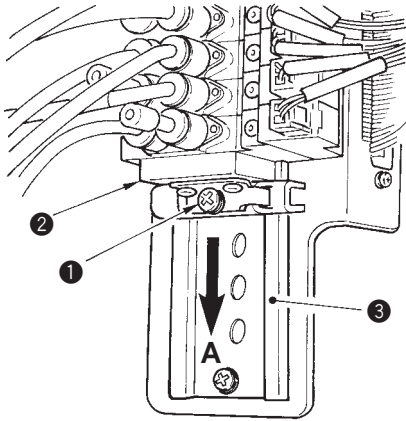

Adjustment Procedures

Results of Improper Adjustment

1) Piping the knife base cylinder

1. Loosen setscrew ① in the end block, draw end block ② in the direction A, and draw it out from rail ③.
2. Attach three bushes supplied with the device as accessories to solenoid valve ④ and insert solenoid valve ④ into rail ③.
3. Insert end block ② into rail ③ and making the solenoid valve ④ come in close contact with it, tighten setscrew ①.

(Caution) 1. When tightening setscrew ①, air leakage will be caused unless the respective solenoid valves come in close contact with each other. Be careful that there is no clearance between them.

- 2. Check that the bushes supplied with the device as accessories are put between the respective solenoid valves and the end block ②.**

4. Connect solenoid valve cable ⑦ to solenoid valve ④.
5. Insert the pins of solenoid valve cable ⑦ to the designated places of connector ⑧.

Cable color	Connector No.
Red	21
Black	22

6. Fix the air tubes with cable clip ⑨ and setscrew ⑩ supplied with the device as accessories, loosen two gimp pipe B setscrews ⑫ and pass the air tubes between gimp pipe B ⑪ and the machine bed.
7. Pass them under lengthwise feed guide shaft fixing base ⑬ and insert them into the inside of the machine bed.
8. Perform piping of the air tubes up to the bottom of the machine table as shown in the illustration and fix them with the air tube of the cloth chip suction device with the clip band ⑭ supplied with the device as accessories.
9. Connect the air tube on the side where the cloth cutting knife (eyelet) tilts to port A.
10. Connect the air tube on the side where the cloth cutting knife (eyelet) rises to port B.

Standard Adjustment

2) Piping the cloth chip suction device

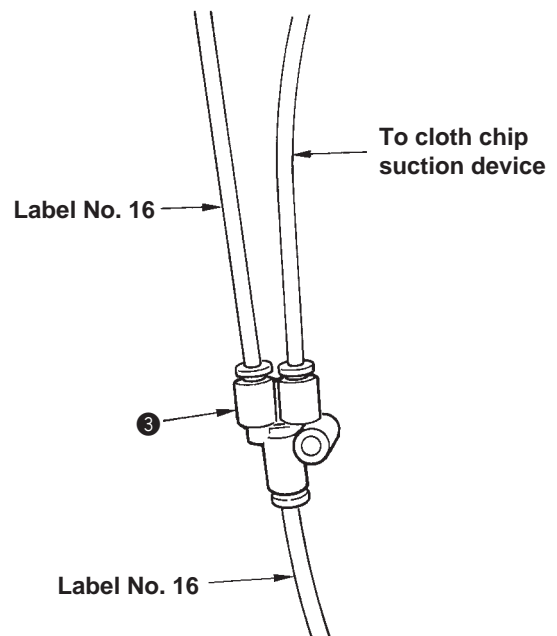
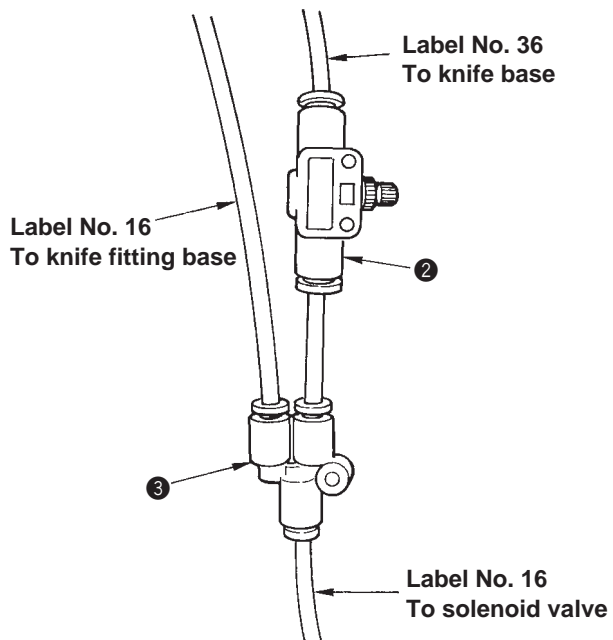
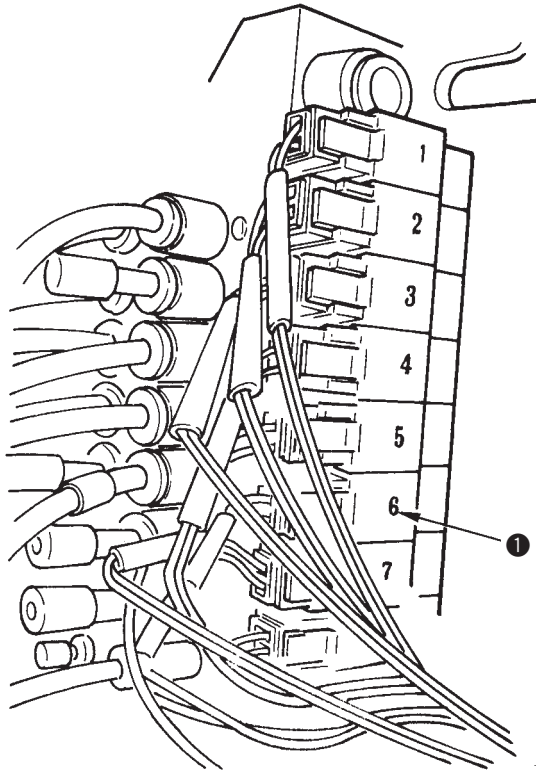

Adjustment Procedures	Results of Improper Adjustment
<p>2) Piping the cloth chip suction device</p> <ol style="list-style-type: none">1. Remove the piping of label No. 36 (to knife base) of solenoid valve No. 6 (cloth chip blow) ❶ from the end of Y joint ❸. (Including speed controller ❷)2. Insert the piping from the cloth chip device into Y joint ❸ from which the piping has been removed.	

(4) Adjusting the multicutting device

1) Adjusting the knife

Standard Adjustment

① Adjusting the longitudinal position of the cloth cutting knife

Adjust the distance from the top of eyelet to the center of the needle bar at the time of cloth cutting to 54 mm. (As a substitute characteristic, adjust the distance from the center of the needle bar to the edge of stopper section of knife stopper ❶ to 55.9 mm to nearly obtain the target value.)

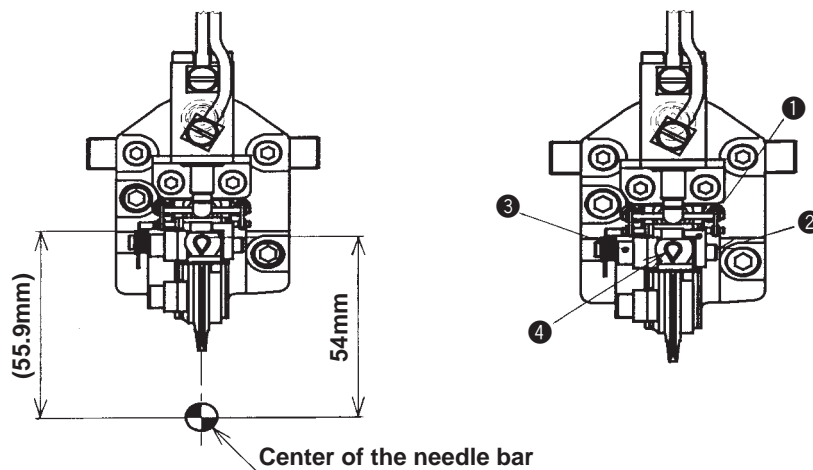

② Adjusting the lateral position of the cloth cutting knife

Adjust knife base ❸ so that cloth cutting section is laterally equal to the stitches of parallel section.

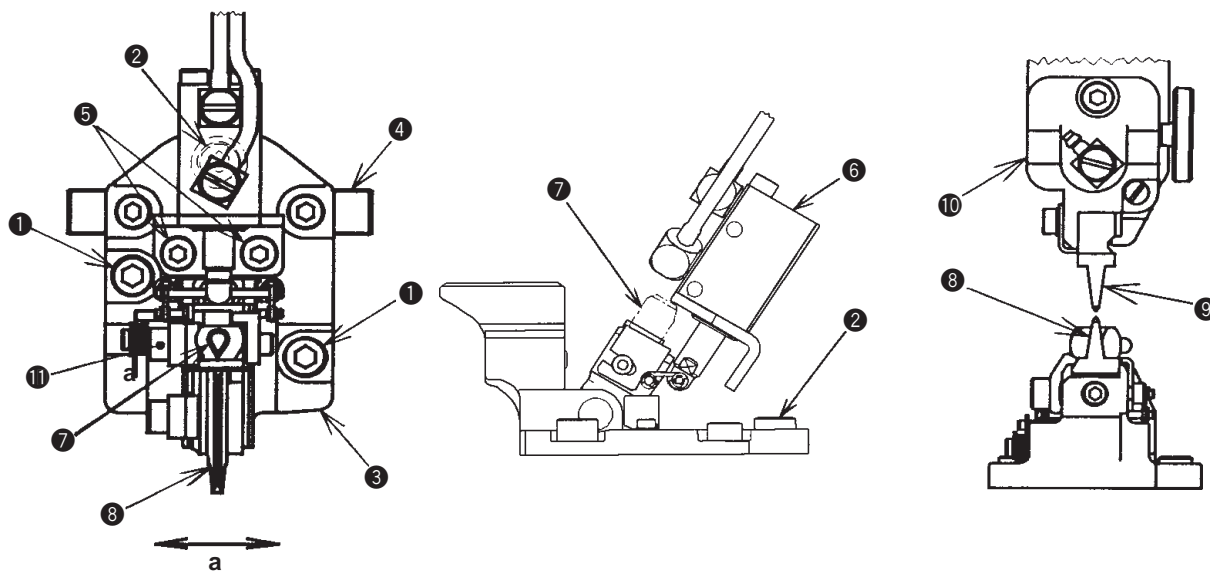

Adjustment Procedures	Results of Improper Adjustment
<ol style="list-style-type: none"> 1. Loosen setscrew ② in the knife stopper. 2. Loosen setscrew ③ in the knife fixing plate and adjust the position of cloth cutting knife (eyelet) ④ so that the portion where cloth cutting knife (eyelet) ④ comes in contact with knife stopper ① is 55.9 mm from the center of the needle bar. Then tighten setscrew ③ in the knife fixing plate. 3. Push knife stopper ① to cloth cutting knife (eyelet) and tighten setscrew ② in the knife stopper to fix it. 	<p>When the cloth cutting knife is longitudinally out of place :</p> <ul style="list-style-type: none"> ○ In case of the cut-after knife, the seams at the top of eyelet or seams at the narrow section of eyelet are cut. ○ In case of the cut-before knife, seams near the top of eyelet are deformed.
<ol style="list-style-type: none"> 1. Cut off the air of the regulator. 2. Loosen setscrew ⑪ in the knife fixing plate and remove cloth cutting knife (eyelet) ⑦. 3. Remove two setscrews ⑤ in the cylinder installing plate and put cloth cutting cylinder ⑥ in the raised state. 4. Loosen two setscrews ① and one setscrew ② in the knife base, and make knife base ③ and knife base key ④ move in one body. 5. Return cloth cutting cylinder ⑥ to its home position, temporarily tighten two setscrews ⑤ in the cylinder installing plate, and supply the air of regulator. 6. Move knife base ③ and knife base key ④ in one body to the right and left as the arrow mark a to adjust the position of the knife. 7. When the position is determined, fix two setscrews ① in the knife base. 8. Remove two setscrews ⑤ in the cylinder installing plate and put cloth cutting cylinder ⑥ in the raised state. Then fix one setscrew ② in the knife base. 9. Return cloth cutting cylinder ⑥ to its home position and fix two setscrews ⑤ in the cylinder installing plate. <p>(Caution) When changing from the standard cloth cutting knife to the multicutting device, install cloth cutting knife (decorative buttonhole) ⑨ on knife installing base ⑩, and making this as the standard, adjust cloth cutting knife (straight) ⑧ to cloth cutting knife (decorative buttonhole) ⑨ to comparatively perform the adjustment with ease.</p>	<p>When the cloth cutting knife is laterally out of place :</p> <ul style="list-style-type: none"> ○ In case of the cut-after knife, seams of eyelet section and parallel section are cut. ○ In case of the cut-before knife, seams of parallel section and eyelet section are deformed.

Standard Adjustment

③ Adjusting the inclination of the cloth cutting knife

Adjust knife base ③ so that the cutting section is parallel to the stitches of parallel section.

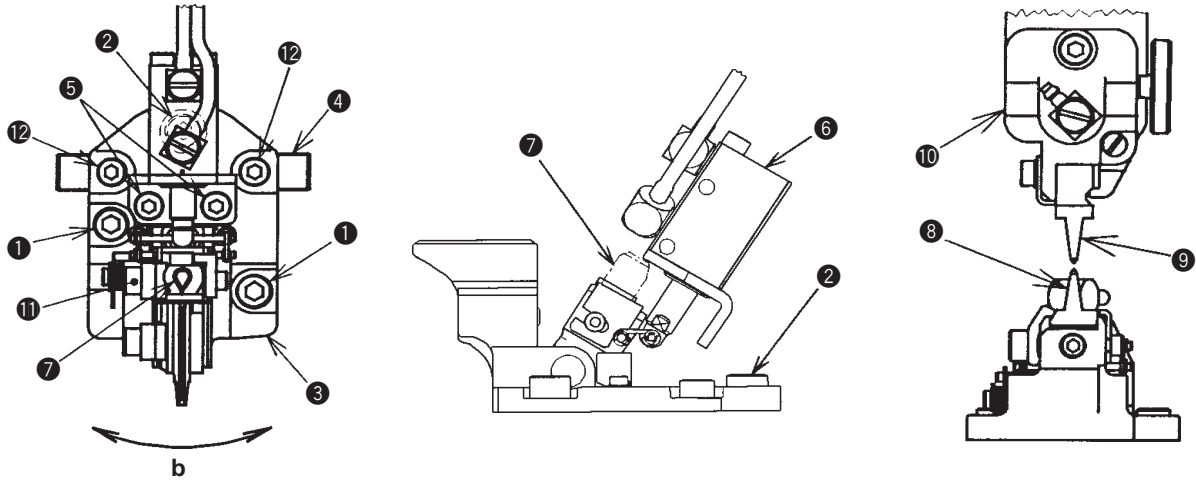

2) Timing between the needle and the looper

Standard Adjustment

① Adjusting the inclination of the cloth cutting knife (eyelet)

Adjust knife base B ⑤ so that the cutting edge plane (plane Y) of cloth cutting knife (eyelet) ① is parallel to the installing plane (plane Z) of knife base ④.

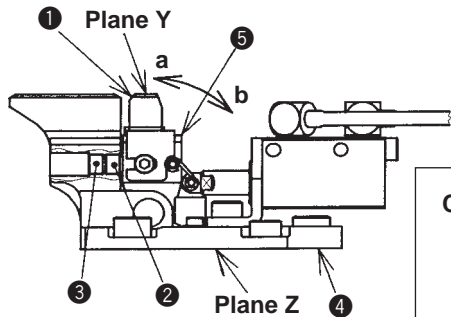

Cutting state of eyelet section according to the inclination of knife



Normal

OK



Inclined in the direction b

NG



Inclined in the direction a

NG

— : Eyelet section is cut.
- - - : Eyelet section is not cut.

Adjustment Procedures	Results of Improper Adjustment
<ol style="list-style-type: none"> 1. Cut off the air of the regulator. 2. Loosen setscrew ⑪ in the knife fixing plate and remove cloth cutting knife (eyelet) ⑦. 3. Remove two setscrews ⑤ in the cylinder installing plate and put cloth cutting cylinder ⑥ in the raised state. 4. Loosen two setscrews ① and one setscrew ② in the knife base, and two setscrews ⑫ in the knife base key. 5. Return cloth cutting cylinder ⑥ to its home position, temporarily tighten two setscrews ⑤ in the cylinder installing plate, and supply the air of the regulator. 6. Move knife base ③ to the right and left as the arrow mark b and adjust the inclination. 7. When the position is determined, fix two setscrews ① in the knife base. 8. Remove two setscrews ⑤ in the cylinder installing plate and put cloth cutting cylinder ⑥ in the raised state. Then fix one setscrew ② in the knife base. 9. Return cloth cutting cylinder to its home position and fix two setscrews ⑤ in the cylinder installing plate. <p>(Caution) When changing from the standard cloth cutting knife to the multicutting device, install cloth cutting knife (decorative buttonhole) ⑨ on knife installing base ⑩, and making this as the standard, adjust cloth cutting knife (straight) ⑧ to cloth cutting knife (decorative buttonhole) ⑨ to comparatively perform the adjustment with ease.</p>	<p>When the cloth cutting knife is inclined :</p> <ul style="list-style-type: none"> ○ In case of the cut-after knife, seams of eyelet section and parallel section are cut. ○ In case of the cut-before knife, seams of parallel section and eyelet section are deformed.

Adjustment Procedures	Results of Improper Adjustment
<ol style="list-style-type: none"> 1. Remove adjusting screw ③ in the knife base from knife base ④. 2. Turn adjusting screw ② in the knife base and adjust so that the cutting edge plane (plane Y) of cloth cutting knife (eyelet) ① is parallel to the installing plane (plane Z) of knife base ④. 3. Insert adjusting screw ③ in the knife base into knife base ④ and fix adjusting screw ② in the knife base so that it does not move. <p>(Caution)</p> <ol style="list-style-type: none"> 1. When adjusting screw ② in the knife base is tightened, knife base B ⑤ is inclined in the direction b. 2. When adjusting screw ② in the knife base is loosened, knife base B ⑤ is inclined in the direction a. 3. When tightening adjusting screw ③ in the knife base, adjusting screw ② in the knife base moves and the inclination of knife base B ⑤ may change. 4. To check that plane Y and plane Z are parallel to each other, cut the material which is actually sewn and check the parallelism. 	<p>When the cloth cutting knife (eyelet) is inclined :</p> <ul style="list-style-type: none"> ○ Eyelet section is not partially cut. ○ Cloth cutting knife (eyelet) may be broken.

Standard Adjustment

② Adjusting the lateral position of knife holder

Adjust the height of cloth cutting knife (straight) ② so that the difference in level between the cutting edge plane (plane A) of cloth cutting knife (straight) ② and the cutting edge plane (plane B) of cloth cutting knife (eyelet) ① is 0.03 mm or less.

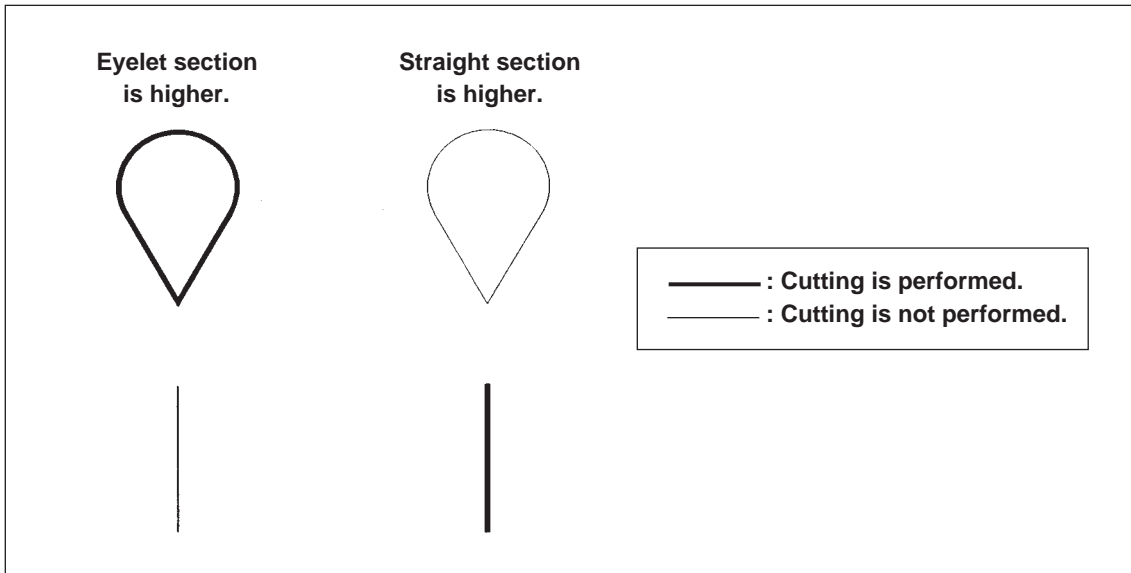
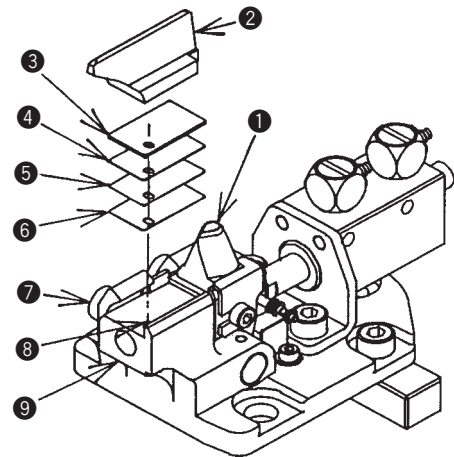
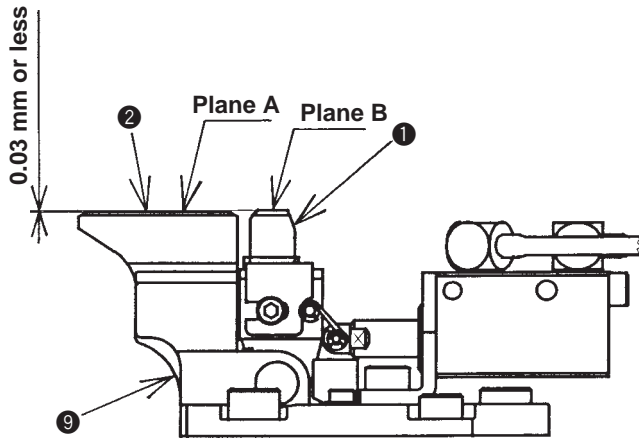

No.	Part No.	Part Name	Thickness
③	32086605	Cloth cutting knife base spacer A	0.6 mm
④	32086704	Cloth cutting knife base spacer B	0.1 mm
⑤	32086803	Cloth cutting knife base spacer C	0.12 mm
⑥	32086902	Cloth cutting knife base spacer D	0.15 mm

Adjustment Procedures	Results of Improper Adjustment
<ol style="list-style-type: none"> 1. Loosen setscrew ⑦ in the knife fixing plate and remove cloth cutting knife (straight) ②. 2. Remove cloth cutting knife base spacer A ③. 3. Combine cloth cutting knife base spacers B ④, C ⑤ and D ⑥ with each other so that the difference in level between the cutting edge section of cloth cutting knife (eyelet) ① and that of cloth cutting knife (straight) ② is 0.03 mm or less. 4. Adjust the long hole sections of cloth cutting knife base spacers B to D (④ to ⑥) to spring pin ⑧ and set them to knife base ⑨. 5. Adjust the long hole section of cloth cutting knife base spacer A ③ to spring pin ⑧ and set it on cloth cutting knife base spacers B to D (④ to ⑥). 6. Set cloth cutting knife (straight) ② and tighten setscrew ⑦ in the knife fixing plate. <p>(Caution)</p> <ol style="list-style-type: none"> 1. For the difference in level between cloth cutting knife (eyelet) ① and cloth cutting knife (straight) ②, actually cut the material which is sewn and combine cloth cutting knife base spacers A to D (③ to ⑥) with each other so that both eyelet section and straight section can be cut. 2. Be sure to adjust the long holes of cloth cutting knife base spacers A to D (③ to ⑥) to spring pin ⑧ and set them. 	<p>When the difference in level between the respective cloth cutting knives :</p> <ul style="list-style-type: none"> ○ Either eyelet section or straight section is not cut. ○ Press mark of knife holder is not equally attached.

(5) Adjusting the pneumatic components

Standard Adjustment

1) Adjusting the speed controller

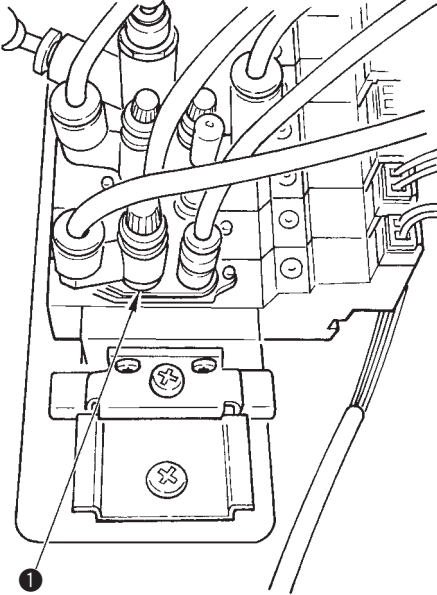

The diagram shows a detailed view of the speed controller assembly. It includes several pneumatic cylinders, hoses, and electrical connections. A callout '1' points to a specific adjustment point on the assembly.

(6) Setting the DIP switch

Standard Adjustment

Cloth cutting type can be changed with DIP-SW 4 located on the back of machine head.

OFF

1

2

3

4

5

6

7

8

DIP-SW 4	Cloth cutting type
OFF	Standard
ON	Multicutting

Adjustment Procedures	Results of Improper Adjustment
<p>1) Adjusting the speed controller</p> <p>Adjust speed controller ❶ to such an extent that there is shock when returning the cloth cutting knife (eyelet) from the tilted state.</p> <p>(Standard : Adjust the adjustment screw of the speed controller ❶ to the open by approximately one turn from the full close. <Speed controller has been factory-adjusted at the time of delivery.>)</p> <p>(Caution) When the return speed of cloth cutting knife (eyelet) is too fast, the position of cloth cutting knife may slip.</p>	

Adjustment Procedures	Results of Improper Adjustment
<p>1. Turn ON DIP-SW 4 to select the multicutting.</p>	

(7) Replacing the cloth cutting knife

Standard Adjustment

1) Replacing the cloth cutting knife (eyelet)

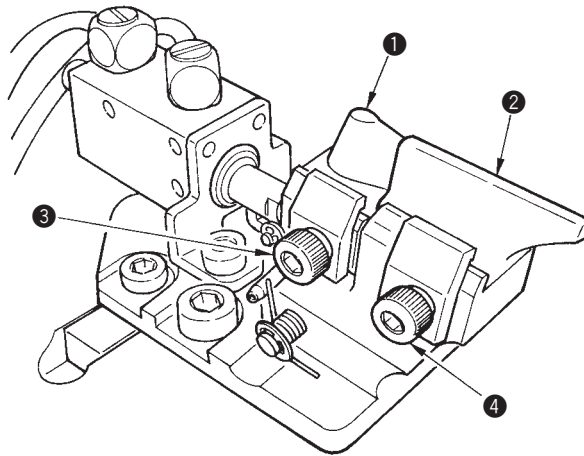

2) Replacing the cloth cutting knife (straight)

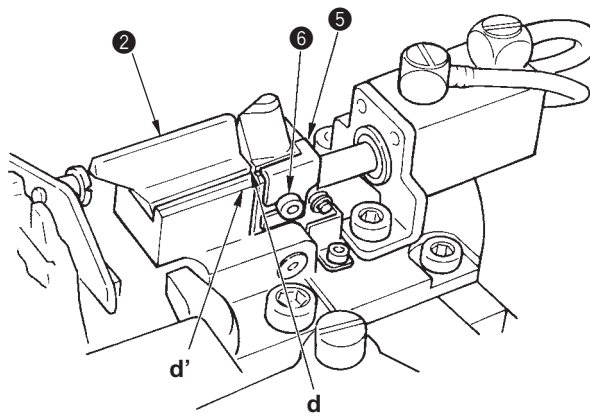

Adjustment Procedures	Results of Improper Adjustment
<p>1) Replacing the cloth cutting knife (eyelet)</p> <ol style="list-style-type: none"> 1. Loosen setscrew ③ and remove cloth cutting knife (eyelet) ①. 2. Press the knife you desire to replace to stopper ⑤ and tighten setscrew ③ to fix the knife. <p>(Caution) Do not loosen screw ⑥ since stopper ⑤ is for positioning.</p>	<ul style="list-style-type: none"> ○ When setscrew ③ is excessively tightened, cloth cutting knife (eyelet) ① may be broken.
<p>2) Replacing the cloth cutting knife (straight)</p> <ol style="list-style-type: none"> 1. Loosen setscrew ④ and remove cloth cutting knife (straight) ②. 2. Adjust edge “d” of the knife you desire to replace to edge “d” of knife base A and tighten setscrew ④ to fix the knife. 	<ul style="list-style-type: none"> ○ When setscrew ④ is excessively tightened, cloth cutting knife (straight) ② may be broken.

(8) Adjusting the cloth cutting knife pressure

Standard Adjustment

1) Adjusting the knife pressing amount

- Knife pressing amount of the cloth cutting knife can be changed.
- When replacing the cloth cutting knife or the knife holder, or sewing material is changed, it is necessary to adjust the knife pressing amount or the stopping time of the knife lower position (refer to Instruction Manual for MEB-3200).
- Perform the change of set value after fully performing checking of the knife holder face and the knife.
- Gradually increase any set value from the small amount while checking the set value.

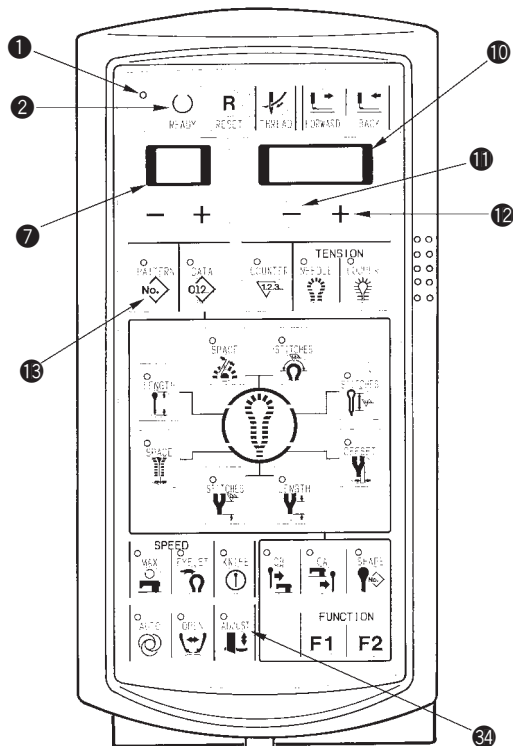

When panel display is a. ① and b. ①

<Display of panel>

a. Knife holder No. when pattern setting is unacceptable :

① Knife adjustment of eyelet + parallel section

② Knife adjustment of parallel section only

b. Knife holder No. when pattern setting is acceptable :



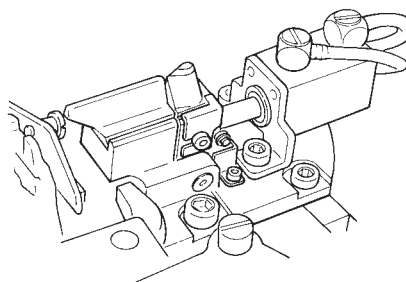

① Knife adjustment of eyelet + parallel section

② Knife adjustment of parallel section only

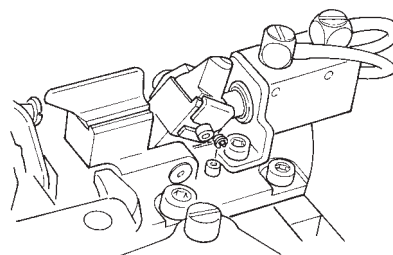

When panel display is a. ② and b. ②



Adjustment Procedures	Results of Improper Adjustment
<p>1) Adjusting the knife pressing amount</p> <ol style="list-style-type: none"> 1. Pressing ADJUST key 34, turn ON the power to the machine. 2. State of the knife to be adjusted is displayed in 2-digit LED 7 and the pressing amount set is displayed in 4-digit LED 10. 3. Press READY key 2 to light up the sewing LED 1. (At this time, feed base, looper bracket and cloth cutting knife perform origin retrieval.) 4. Display of 2-digit LED 7 is changed over by pressing PATTERN key 13 and the state of the knife to be adjusted (eyelet + parallel section or parallel section) (When display of 2-digit LED 7 is "1." : Eyelet + parallel section When display of 2-digit LED 7 is "2." : Parallel section only) <Refer to display of panel a. ① and ②.> 5. The pressing amount can be set with RIGHT  key 11 or RIGHT  key 12. (The setting range is – 100 to 300. The more the number is, the higher the cloth cutting knife pressure becomes.) 6. Lower the presser with the presser switch and press the start switch to actuate the knife. The pressing amount can be set again using RIGHT  key 11 or RIGHT  key 12 with the presser raised. 7. Perform the adjustment of knife for "eyelet + parallel section" or "parallel section only". 8. After completion of the setting, press ADJUST key 34 to complete the knife adjustment mode and to change to the sewing mode. 10 kinds of the knife pressing amounts can be set to the pattern data with memory switch No. 40. (Refer to "10.-(8) Setting the pattern data of cloth cutting knife pressing amount" of the Instruction Manual for MEB-3200.) At this time, the display of panel is as shown in b. ① and ②. <p>(Caution)</p> <ol style="list-style-type: none"> 1. The set value is stored in memory when the knife is actuated by the start switch or ADJUST key 34 is pressed. When turning OFF the power without performing either operation, the set value is not stored in memory. 2. Set the knife pressing amount as small as possible in order to protect the knife and the knife holder, and maintain the durability. 	<ul style="list-style-type: none"> ○ If the pressing amount is excessively large, malfunction of the drive motor or breakage of the knife will be caused.

(9) Setting the pattern data

Standard Adjustment

1) Setting the knife No.

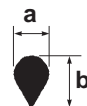
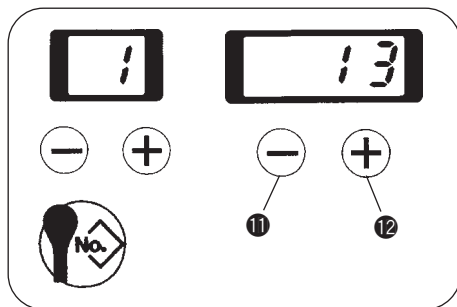





13 or 16 ... Eyelet
(Setting : 11 to 16)

(⊙ : Standard)

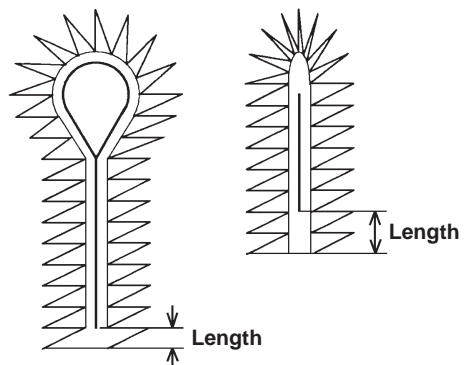
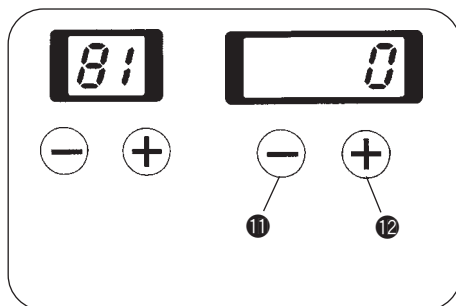
No.	a x b
11	2.1 x 3.2
12	2.5 x 3.8
⊙ 13	2.9 x 4.4
14	3.0 x 4.6
15	3.2 x 5.4
16	2.7 x 5.1

2) Cut length compensation



Adjustment Procedures	Results of Improper Adjustment
<p>1) Setting the knife No.</p> <ol style="list-style-type: none"> 1. Set the knife No. of the same form as that of the knife mounted on the sewing machine and determine the multicutting operation. 2. Set the knife No. with RIGHT  key ⑪ or RIGHT  key ⑫. In case of the multicutting device set 13 (standard) or 16 (optional). However, setting can be performed up to No. 11 to 16 in the list and by setting the optional knife No., it is possible to perform sewing by increasing or decreasing the eyelet shape in terms of the form of eyelet knife mounted on the sewing machine. [When performing the decorative buttonhole sewing, set "Plural times selection : data No. 83" to "1" and change the respective sewing data without changing the knife No. to perform the sewing.] <p>(Caution) In case of setting knife Nos. 0 to 6, the knife operates only once.</p>	
<p>2) Cut length compensation</p> <ol style="list-style-type: none"> 1. Cut length in terms of the sewing length can be shortened. 2. Set the cut length with RIGHT  key ⑪ or RIGHT  key ⑫. The length can be set in increments of 1 mm up to 0 (cut length - knife holder length). 	

Standard Adjustment

3) Plural times selection

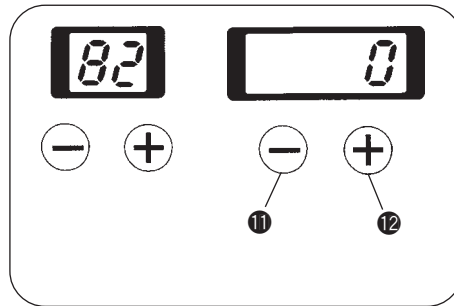

0 : Eyelet buttonhole



1 : Decorative buttonhole

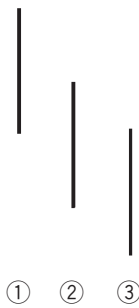

2 : Eyelet buttonhole

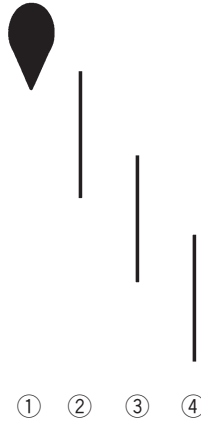

3 : Eyelet buttonhole only





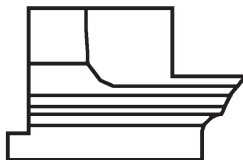



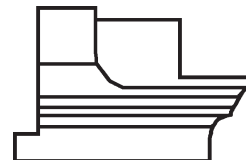

Shape of the knife holder : Without step
(Parts No. 32087603, 32087702, 32087801)



Shape of the knife holder : With step
(Parts No. 32087900, 32088007, 32088106)



Adjustment Procedures	Results of Improper Adjustment
<p>3) Plural times selection</p> <ol style="list-style-type: none"> 1. Set the operation pattern of the cloth cutting knife. 2. The pattern can be set with RIGHT  key  or RIGHT  key . <p style="margin-left: 40px;">When using knife holder without step : 0 or 1 When using knife holder with step : 1, 2 or 3</p> <p>[In case of using the knife holder with step, the knife operation may be more than the case of using the knife holder without step at the time of the same cutting length.]</p> <ol style="list-style-type: none"> 3. The order of operation of the cloth cutting knife is shown in the order of , ,  and . <p>(Caution) In case of using the knife holder with step, be careful of the thickness of material. (In case of thick material, not only the eyelet buttonhole but also the straight portion may be cut.)</p>	

Standard Adjustment

4) Decorative buttonhole offset

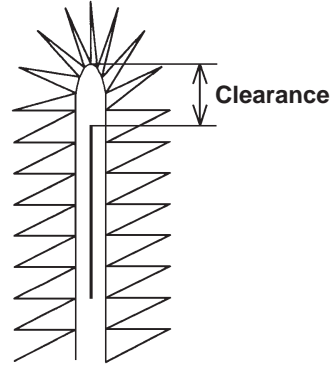
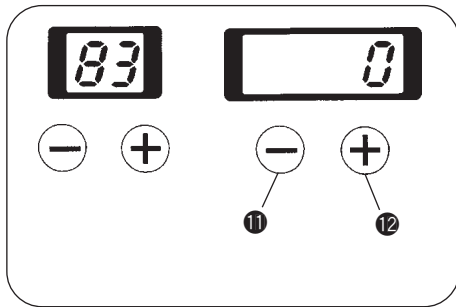

(10) Memory switch

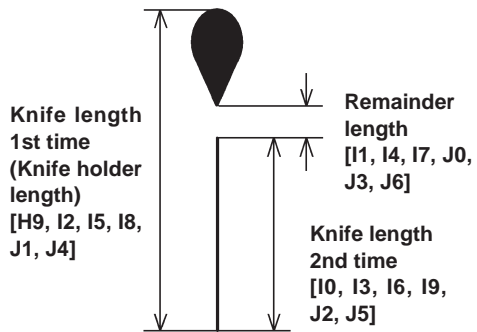

Standard Adjustment

Setting place of memory switch Nos. H9 to J6



(⊙ : Provided as standard)

Knife No.	Memory switch No.	Knife holder (Part No.)			Remarks
		32087801 32088106	32087702 32088007	32087603 32087900	
—	H9, I2, I5, I8, J1, J4	18	26	32	Without step With step
—	I0, I3, I6, I9, J2, J5	8	16	22	
11	I1	6	6	6	
12	I4	5	5	5	
⊙ 13	I7	5	5	5	
14	J0	5	5	5	
15	J3	4	4	4	
16	J6	4	4	4	

Adjustment Procedures	Results of Improper Adjustment
<p>4) Decorative buttonhole offset</p> <ol style="list-style-type: none"> 1. Clearance from the top of the stitches of decorative buttonhole to the cutting position can be set. 2. Set the clearance with RIGHT  key 11 or RIGHT  key 12. <p>The clearance can be set in increments of 1 mm up to 0 (cut length - knife holder length - cut length compensation value). It is effective only when the data No. 82 is "1".</p>	

Adjustment Procedures	Results of Improper Adjustment
<ol style="list-style-type: none"> 1. Start the memory switch. (READY key + Power ON) 2. Set the memory switch Nos. H9 to J6 in accordance with the knife holder length and knife No. as listed in the table below. (Standard value at the time of knife holder length = 18 mm) <p>(Caution) It is effective only when knife Nos. 11 to 16 are selected.</p>	

Memory switch

No.	Function	Description	Standard value	Setting range	Unit	Level
40	Knife holder No. Pattern setting acceptable	0 : Setting knife holder No. to pattern data unacceptable 1 : Setting acceptable	0	0 to 1	–	1
41	Knife adjustment value 1	Knife adjustment value 1 Adjustment value 1 of number of pulses of knife moving at the time of cloth cutting of eyelet section (Knife holder No. 1)	0	–100 to 300	Pulse	1
42	Knife adjustment value 2	Knife adjustment value 2 Adjustment value 1 of number of pulses of knife moving at the time of cloth cutting of eyelet section (Knife holder No. 2)	0	–100 to 300	Pulse	1
43	Knife adjustment value 3	Knife adjustment value 3 Adjustment value 1 of number of pulses of knife moving at the time of cloth cutting of eyelet section (Knife holder No. 3)	0	–100 to 300	Pulse	1
44	Knife adjustment value 4	Knife adjustment value 4 Adjustment value 1 of number of pulses of knife moving at the time of cloth cutting of eyelet section (Knife holder No. 4)	0	–100 to 300	Pulse	1
45	Knife adjustment value 5	Knife adjustment value 5 Adjustment value 1 of number of pulses of knife moving at the time of cloth cutting of eyelet section (Knife holder No. 5)	0	–100 to 300	Pulse	1
46	Knife adjustment value 6	Knife adjustment value 6 Adjustment value 1 of number of pulses of knife moving at the time of cloth cutting of eyelet section (Knife holder No. 6)	0	–100 to 300	Pulse	1
47	Knife adjustment value 7	Knife adjustment value 7 Adjustment value 1 of number of pulses of knife moving at the time of cloth cutting of eyelet section (Knife holder No. 7)	0	–100 to 300	Pulse	1
48	Knife adjustment value 8	Knife adjustment value 8 Adjustment value 1 of number of pulses of knife moving at the time of cloth cutting of eyelet section (Knife holder No. 8)	0	–100 to 300	Pulse	1
49	Knife adjustment value 9	Knife adjustment value 9 Adjustment value 1 of number of pulses of knife moving at the time of cloth cutting of eyelet section (Knife holder No. 9)	0	–100 to 300	Pulse	1
50	Knife adjustment value 0	Knife adjustment value 0 Adjustment value 1 of number of pulses of knife moving at the time of cloth cutting of eyelet section (Knife holder No. 0)	30	–100 to 300	Pulse	1
G0	Plural times knife 11, width of eyelet	Knife No.=11 of width of eyelet	2.1 mm	1.0 to 4.0	0.1 mm	2
G1	Plural times knife 11, length of eyelet	Knife No.=11 of length of eyelet	3.2 mm	1.0 to 8.0	0.1 mm	2
G2	Plural times knife 12, width of eyelet	Knife No.=12 of width of eyelet	2.5 mm	1.0 to 4.0	0.1 mm	2
G3	Plural times knife 12, length of eyelet	Knife No.=12 of length of eyelet	3.8 mm	1.0 to 8.0	0.1 mm	2
G4	Plural times knife 13, width of eyelet	Knife No.=13 of width of eyelet	2.9 mm	1.0 to 4.0	0.1 mm	2
G5	Plural times knife 13, length of eyelet	Knife No.=13 of length of eyelet	4.4 mm	1.0 to 8.0	0.1 mm	2
G6	Plural times knife 14, width of eyelet	Knife No.=14 of width of eyelet	3.0 mm	1.0 to 4.0	0.1 mm	2
G7	Plural times knife 14, length of eyelet	Knife No.=14 of length of eyelet	4.6 mm	1.0 to 8.0	0.1 mm	2
G8	Plural times knife 15, width of eyelet	Knife No.=15 of width of eyelet	3.2 mm	1.0 to 4.0	0.1 mm	2
G9	Plural times knife 15, length of eyelet	Knife No.=15 of length of eyelet	5.4 mm	1.0 to 8.0	0.1 mm	2
H0	Plural times knife 16, width of eyelet	Knife No.=16 of width of eyelet	2.7 mm	1.0 to 4.0	0.1 mm	2
H1	Plural times knife 16, length of eyelet	Knife No.=16 of length of eyelet	5.1 mm	1.0 to 8.0	0.1 mm	2
H9	Plural times knife 11, knife length 1st time	1st time knife length of knife No. 11	18	10 to 38	mm	1
I0	Plural times knife 11, knife length 2nd time	2nd time knife length of knife No. 11	8	5 to 38	mm	1
I1	Plural times knife 11, remainder cut amount	Remainder cut length between eyelet and parallel section of knife No. 11	6	0 to 20	mm	1
I2	Plural times knife 12, knife length 1st time	1st time knife length of knife No. 12	18	10 to 38	mm	1
I3	Plural times knife 12, knife length 2nd time	2nd time knife length of knife No. 12	8	5 to 38	mm	1
I4	Plural times knife 12, remainder cut amount	Remainder cut length between eyelet and parallel section of knife No. 12	5	0 to 20	mm	1
I5	Plural times knife 13, knife length 1st time	1st time knife length of knife No. 13	18	10 to 38	mm	1

No.	Function	Description	Standard value	Setting range	Unit	Level
I6	Plural times knife 13, knife length 2nd time	2nd time knife length of knife No. 13	8	5 to 38	mm	1
I7	Plural times knife 13, remainder cut amount	Remainder cut length between eyelet and parallel section of knife No. 13	5	0 to 20	mm	1
I8	Plural times knife 14, knife length 1st time	1st time knife length of knife No. 14	18	10 to 38	mm	1
I9	Plural times knife 14, knife length 2nd time	2nd time knife length of knife No. 14	8	5 to 38	mm	1
J0	Plural times knife 14, remainder cut amount	Remainder cut length between eyelet and parallel section of knife No. 14	5	0 to 20	mm	1
J1	Plural times knife 15, knife length 1st time	1st time knife length of knife No. 15	18	10 to 38	mm	1
J2	Plural times knife 15, knife length 2nd time	2nd time knife length of knife No. 15	8	5 to 38	mm	1
J3	Plural times knife 15, remainder cut amount	Remainder cut length between eyelet and parallel section of knife No. 15	4	0 to 20	mm	1
J4	Plural times knife 16, knife length 1st time	1st time knife length of knife No. 16	18	10 to 38	mm	1
J5	Plural times knife 16, knife length 2nd time	2nd time knife length of knife No. 16	8	5 to 38	mm	1
J6	Plural times knife 16, remainder cut amount	Remainder cut length between eyelet and parallel section of knife No. 16	4	0 to 20	mm	1
K6	Plural times knife, gimp and bobbin thread haul delay time	Time from gimp and bobbin thread haul to bobbin thread trimming ON at the time of long thread trimming	150	0 to 1000	ms	2
K7	Plural times knife, multicutting delay time	Time from multicutting ON to start of lowering of cloth cutting knife	100	0 to 1000	ms	2
K8	Plural times knife, multicutting cloth chip chute time	Time from dust chute ON to move of feed base at the time of multicutting ON	200	0 to 1000	ms	2
K9	Plural times knife, multicutting ON cloth cutting knife position	Cloth cutting knife lifting position to make multicutting ON	1000	0 to 1500	Pulse	2
L0	Plural times knife, parallel section knife adjustment value 0	Plural times knife, knife adjustment value of parallel section 0 (Knife holder No. 0)	20	-100 to 300	Pulse	1
L1	Plural times knife, parallel section knife adjustment value 1	Plural times knife, knife adjustment value of parallel section 1 (Knife holder No. 1)	0	-100 to 300	Pulse	1
L2	Plural times knife, parallel section knife adjustment value 2	Plural times knife, knife adjustment value of parallel section 2 (Knife holder No. 2)	0	-100 to 300	Pulse	1
L3	Plural times knife, parallel section knife adjustment value 3	Plural times knife, knife adjustment value of parallel section 3 (Knife holder No. 3)	0	-100 to 300	Pulse	1
L4	Plural times knife, parallel section knife adjustment value 4	Plural times knife, knife adjustment value of parallel section 4 (Knife holder No. 4)	0	-100 to 300	Pulse	1
L5	Plural times knife, parallel section knife adjustment value 5	Plural times knife, knife adjustment value of parallel section 5 (Knife holder No. 5)	0	-100 to 300	Pulse	1
L6	Plural times knife, parallel section knife adjustment value 6	Plural times knife, knife adjustment value of parallel section 6 (Knife holder No. 6)	0	-100 to 300	Pulse	1
L7	Plural times knife, parallel section knife adjustment value 7	Plural times knife, knife adjustment value of parallel section 7 (Knife holder No. 7)	0	-100 to 300	Pulse	1
L8	Plural times knife, parallel section knife adjustment value 8	Plural times knife, knife adjustment value of parallel section 8 (Knife holder No. 8)	0	-100 to 300	Pulse	1
L9	Plural times knife, parallel section knife adjustment value 9	Plural times knife, knife adjustment value of parallel section 9 (Knife holder No. 9)	0	-100 to 300	Pulse	1

(Caution) Memory switch Nos. 40 to 50 and L0 to L9 are set in “15 - (8) ADJUSTING THE CLOTH CUTTING KNIFE PRESSURE”.

(11) Replacement gauge

Knife holder (For both eyelet and decorative buttonhole) (⊙ : Provided as standard, No mark : optional)

Shape of knife holder	Length of knife holder (mm)	Part No.	Max. sewing length (mm)		Min. sewing length (mm)		Sewing type
			Eyelet	Decorative buttonhole	Eyelet	Decorative buttonhole	S
Without step	32	32087603	38	38	32	22	
	26	32087702	38	38	26	16	
	18	32087801	38	38	18	10	⊙
With step	32	32087900	38	38	22	22	
	26	32088007	38	38	16	16	
	18	32088106	38	38	10	10	

Cloth cutting knife (eyelet)

Multicutting type				
Name of eyelet	Part No.	Shape (mm)		Sewing type
		X	Y	S
3A	32087202	2.9	4.4	⊙
6A	32087306	2.7	5.0	

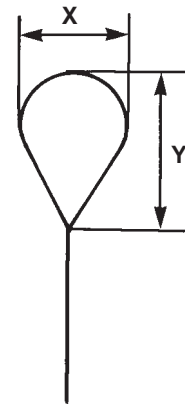

JUKI[®]

JUKI CORPORATION

INTERNATIONAL SALES H.Q.
8-2-1, KOKURYO-CHO,
CHOFU-SHI, TOKYO 182-8655, JAPAN
PHONE : (81)3-3430-4001 to 4005
FAX : (81)3-3430-4909 • 4914 • 4984
TELEX : J22967

Copyright © 2000-2003 JUKI CORPORATION.
All rights reserved throughout the world.

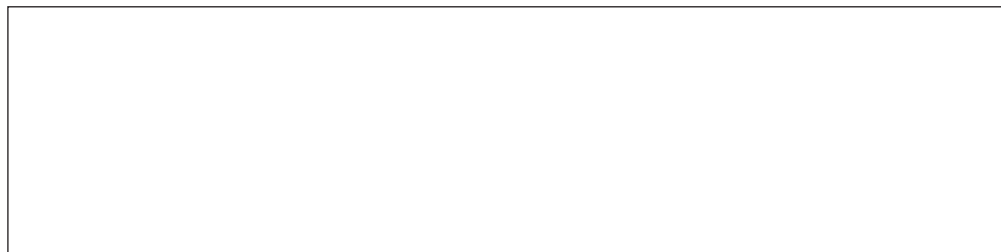

Please do not hesitate to contact our distributors or agents in your area for further information when necessary.
*** The description covered in this engineer's manual is subject to change for improvement of the commodity without notice.**