

SINGER
231-34 AND 231-35

USE ONLY SINGER OILS and LUBRICANTS

*They insure freedom from lubricating trouble and
give longer life to sewing equipment*

“Singer Oil for High Speed Sewing Machines”

(Cloth and Leather)

For all manufacturing sewing machines except where a stainless oil is desired.

“Singer Stainless Oil for High Speed Sewing Machines”

For all manufacturing sewing machines where a stainless oil is desired.

“Singer Motor Oil”

For oil-lubricated motors, power tables, transmitters and machinery in general.

“Singer Stainless Thread Lubricant”

For lubricating the needle thread of sewing machines for stitching fabrics or leather where a stainless thread lubricant is required.

NOTE: All of the above oils are available in 1 quart, 2 quart, 1 gallon and 5 gallon cans or in 55 gallon drums, and can also be supplied in customer's containers.

“Singer Gear Lubricant”

This specially prepared grease is recommended for gear lubrication on manufacturing sewing machines.

“Singer Ball Bearing Lubricant”

This pure grease is specially designed for the lubrication of ball bearings and ball thrust bearings of motors and electric transmitters, ball bearing hangers of power tables, etc.

NOTE: The above greases are furnished in ¼ lb. tubes and 1 lb. and 4 lb. tins.

Copyright, U. S. A., 1923, 1931, 1935 and 1938,
by The Singer Manufacturing Company
All Rights Reserved for all Countries

19073

INSTRUCTIONS FOR USING AND ADJUSTING SINGER SEWING MACHINES 231-34 and 231-35 Feed - Off - The - Arm

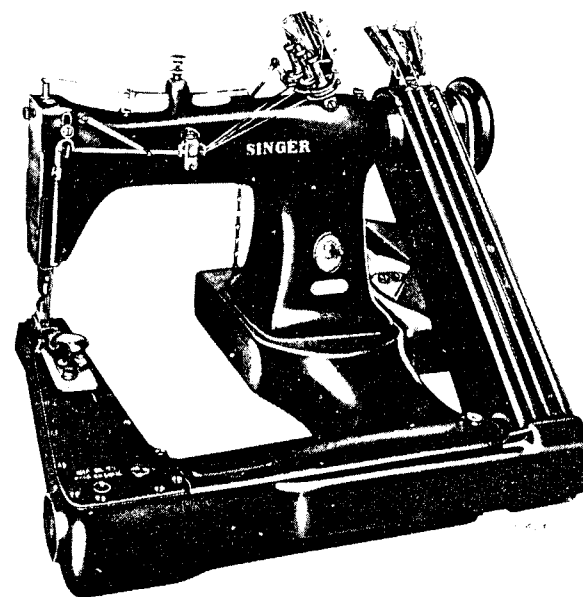

THREE NEEDLES AND THREE LOOPERS
TWO-THREAD CHAIN STITCH

THE SINGER MANUFACTURING CO.

To all whom it may concern:

The placing or renewal of the name "Singer" (Reg. U. S. Pat. Off.) or any of the trade marks of The Singer Manufacturing Company on any machine that has been repaired, rebuilt, reconditioned, or altered in any way whatsoever outside a Singer factory or an authorized Singer agency is forbidden.

THE IMPORTANCE OF USING
GENUINE SINGER PARTS AND NEEDLES
IN SINGER MACHINES

The successful operation of Singer machines can only be assured if genuine Singer parts and needles are used. Supplies are available at all Singer Shops for the Manufacturing Trade and mail orders will receive prompt attention.

Genuine Singer Needles should be used
in Singer Machines.
These Needles and their Containers
are marked with the
Company's Trade Mark "SIMANCO." 1

Needles in Containers marked
"For Singer Machines"
are not Singer made needles. 2

DESCRIPTION

FEED-OFF-THE-ARM MACHINE 231-34 has three needles and three loopers and makes the two-thread chain stitch for lap seam felling work shirts, overalls, etc. of medium weight materials.

The distance between the first and second, and second and third needles may be from 1/8 to 3/16 inch as ordered, the maximum distance between the two outside needles being 3/8 inch.

The machine has a needle bar stroke of 1 3/16 inches and makes from 6 to 18 stitches to the inch.

A splash oiling system oils the feed and looper mechanism, and the needle bar driving mechanism is oiled from a reservoir at the center of the balance wheel.

MACHINE 231-35 is similar to Machine 231-34 except that it has a needle bar stroke of 1 5/16 inches which adapts it for lap seam felling work shirts, overalls, etc. of medium and medium-heavy weight materials.

CAUTION

After setting up, do not start the machine, not even to test the speed, until it has been thoroughly oiled, as instructed on pages 5, 6 and 7.

SPEED

The maximum speed recommended for Machine 231-34 is 3800 R.P.M., and for Machine 231-35, 3600 R.P.M.

The machines should be driven at a speed of approximately 200 R.P.M. less than their maximum speed for the first two or three days, after which they can be driven up to their maximum speed, depending upon the nature of the work and the ability of the operator. When the machine is in operation, the top of the balance wheel turns toward the operator.

Setting Up

Unpack and thoroughly clean the machine. Attach the counterweight to the machine bed as shown in Fig. 5. Insert the two rubber cushions (O, Fig.2) into the holes in the base of the machine. Place the machine in position with the edge of the machine base in line with the edge of the table as shown below, and see that the hole (N) for the presser bar lifter chain is in line with the hole in the table plank.

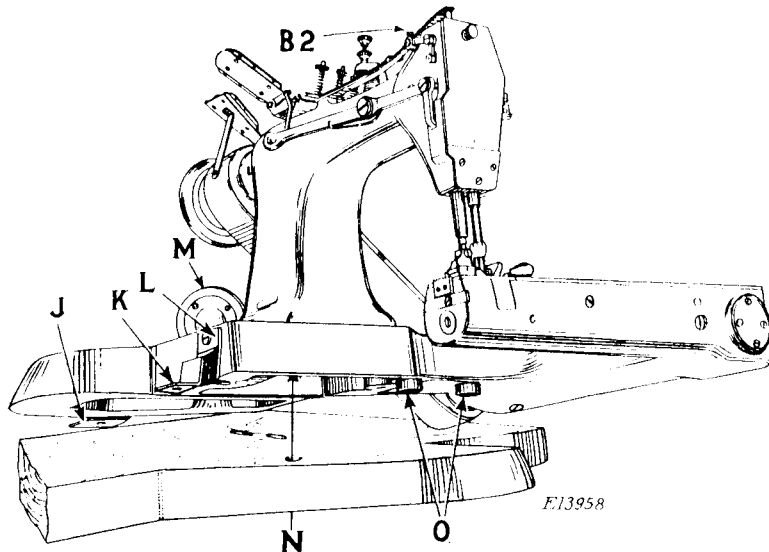

Fig. 2

The two vibration dampeners (J and K, Fig. 2) are placed at the rear of the machine base and at the right of the counterweight as shown in Fig. 2. Attach the straight straps (L) to the machine base and counterweight, then locate and drill holes in the table and fasten the angle straps (K) of the dampeners to the table with 1/4 X 2 1/4 inch bolts.

The cylinder arm cover of the machine should be levelled by placing shims under the rubber cushions or the vibration dampeners. Place a spirit level crosswise on the cylinder arm cover plate, and set the machine with its arm rotary shaft PERFECTLY LEVEL so that the oil will not flood the needle bar driving mechanism in the head. Then place the spirit level lengthwise on the flat cover plate and set the cylinder arm of the machine level. Check the setting occasionally to keep the machine level.

When the machine is operated on a Singer Electric Transmitter Power Table or a Low Shaft Power Table, the idler pulley (M, Fig. 2) is attached to the machine counterweight as shown in Fig. 5.

Needles

Needles for Machines 231-34 and 231-35 are of the following Class and Variety numbers:

149x3 (cloth point) for regular work.

149x4 (leather point) is used for overalls and similar work.

Both of these needles are furnished in sizes 16, 17, 18, 19, 21, 22 and 23.

The size of the needles to be used should be determined by the size of the thread, which must pass freely through the eyes of the needles. If rough or uneven thread is used, or if it passes with difficulty through the eyes of the needles, the machine cannot stitch perfectly.

Orders for needles must specify the QUANTITY required, the SIZE number, and the CLASS and VARIETY numbers separated by the letter x.

The following is an example of an intelligible order:

"100 No. 19, 149x4 Needles"

The best stitching results will be obtained when using the needles furnished by the Singer Sewing Machine Company.

To Set the Needles

Turn the balance wheel over toward you until the needle bar moves up to its highest position and loosen the three set screws in the needle clamp. Place the needles up into the needle clamp as far as they will go, with the single continuous groove in each needle toward you, then tighten the three set screws.

Oiling the Machine

Use only Singer "Stainless Oil for High Speed Sewing Machines" for the lubrication of these machines.

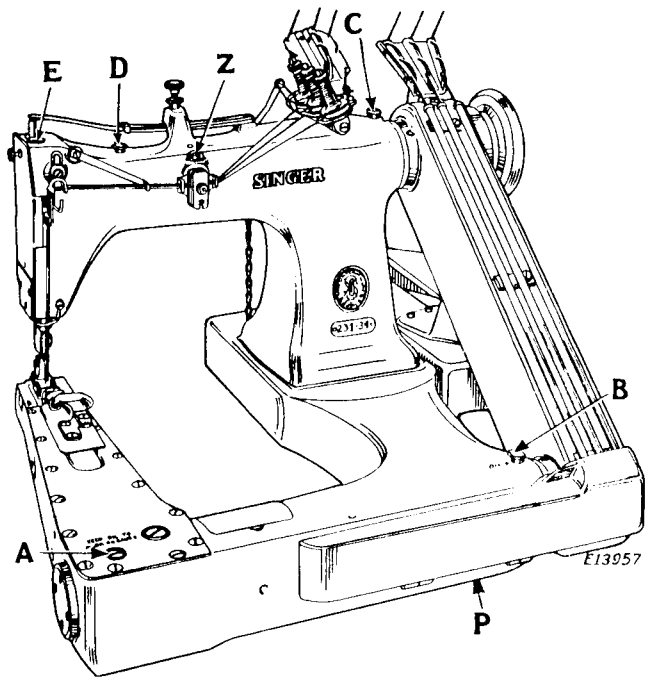

Fig. 3.

All of the oil is drained from the arm reservoir before the machines are shipped from the factory, therefore it is absolutely necessary that the machines be thoroughly oiled according to the following instructions before they are started in operation:

1. After the machine has been set up so that its cylinder arm cover is level, lift out the gauge (A, Fig. 3) and fill the arm reservoir to the level of the mark on the gauge. Run the machine a few minutes, then wipe off the gauge and recheck the oil level. THIS RESERVOIR SHOULD BE FILLED ABOUT TWICE A WEEK OR OFTEN ENOUGH TO KEEP THE OIL LEVEL UP TO THE MARK ON THE GAUGE.

2. Turn the balance wheel to bring the screw plug (F, Fig. 4) to the top, remove this plug and fill the reservoir practically

to the top. THE OIL LEVEL IN THIS RESERVOIR SHOULD NEVER BE ALLOWED TO GO BELOW THE HOLE AT THE CENTER OF THE ARM SHAFT. If the oil is down to the bottom of this hole, add oil before starting. Otherwise run the machine a few minutes before adding oil to this reservoir.

3. Place about 5 drops of oil in each of the three cups (B, C and D, Fig. 3) which lubricate the ball bearings, and in the cup (G, Fig. 5) on the idler pulley underneath the balance wheel. DO THIS ABOUT ONCE A WEEK.

4. Place a drop of oil once a day in the oil hole (Z, Fig. 3) directly above the nipper.

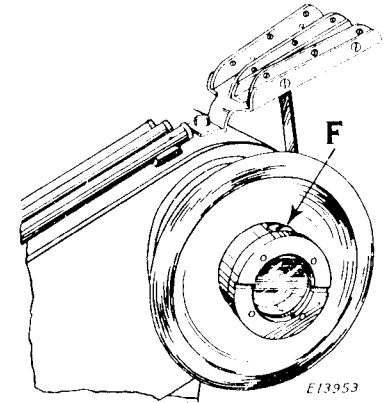

Fig. 4.

NOTICE: When the machine is first set up, or after it has stood idle for some time, put a few drops of oil in the top of the needle bar guide pin (E, Fig. 3) before starting the machine.

OIL DRAIN: Surplus oil from the bearings drains into the wells at the rear of the base (H, Fig. 5) and in the head of the arm (LL, Fig. 17). These wells may be kept empty by soaking out the oil with waste or similar material.

Oil which accumulates in the front of the arm under the rotary shaft should be drained out occasionally by removing the screw plug at (P, Fig. 3) in the bottom of the bed, to prevent oil from getting on the looper thread take-up.

Note: If an excessive amount of oil should flow into the reservoir (LL, Fig. 17), see instructions for replacing the wicking in the arm shaft crank on page 23.

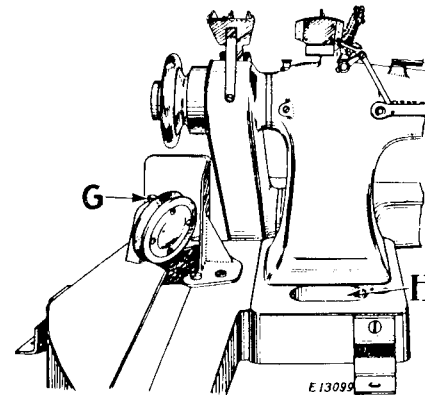

Fig. 5.

Threading the Needles

Turn the balance wheel until the needle bar is at its highest position.

TO THREAD THE LEFT NEEDLE, bring the thread from spool (A1, Fig.6) on the unwinder, down through hole (A2) in the thread guide bar, then down through each of the eyelets (A3,A4 and A5, Fig.7) in the thread straightener as shown. Pass the thread through eyelet (A6), around and between rear tension discs (A7), through eyelet (A8), through needle thread nipper guide (9, Fig.8), between the third and fourth tension plates of nipper (10), through nipper guide (11), through rear eyelet in slack thread regulator (12) and take-up thread guides (13 and 14), down under the retainer plate and through the rear eyelet in take-up (15), down behind wire guide (16), and from front to back through the eye of the left needle (A17).

TO THREAD THE CENTER NEEDLE, bring the thread from spool (B1, Fig.6) on the unwinder, down through hole (B2) in the thread guide bar, then through each of the eyelets (B3,B4 and B5, Fig.7) in the thread straightener as shown. Pass the thread through eyelet (B6), around and between center tension discs (B7), through eyelet (B8), through needle thread nipper guide (9, Fig.8), between the second and third tension plates of nipper (10), through nipper guide (11), through center eyelet in slack thread regulator (12) and take-up thread guides (13 and 14), down under the retainer plate and through the center eyelet in take-up (15), down behind wire guide (16), and from front to back through the eye of the center needle (B17).

TO THREAD THE RIGHT NEEDLE, bring the thread from spool (C1, Fig.6) on the unwinder, down through hole (C2) in the thread guide bar, then down through each of the eyelets (C3,C4 and C5, Fig.7) in the thread straightener as shown. Pass the thread through eyelet guide (CC), through eyelet (C6), around and between front tension discs (C7), through eyelet (C8), through needle thread nipper guide (9, Fig.8), between the first and second plates of nipper (10), through nipper guide (11), through the front eyelet in slack thread regulator (12) and take-up thread guides (13 and 14), down under the retainer plate and through the front eyelet in take-up (15), down behind wire guide (16), and from front to back through the eye of the right needle (C17).

Draw about two inches of thread through the eyes of the needles with which to commence sewing.

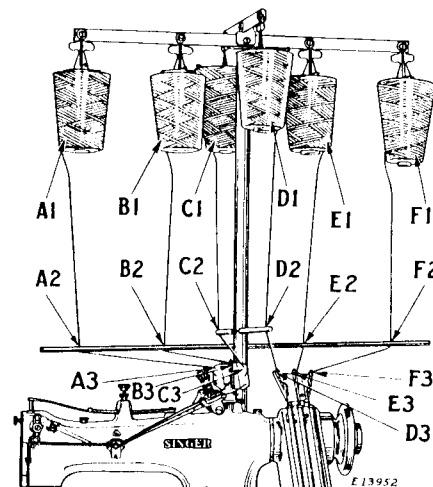

Fig. 6

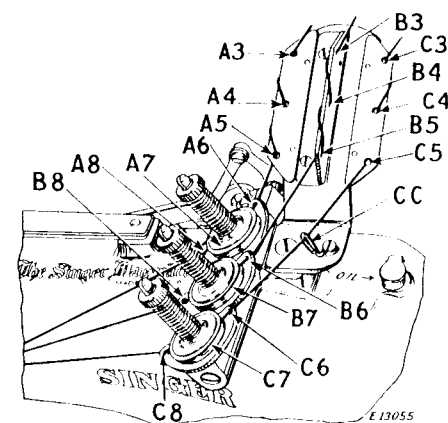

Fig. 7

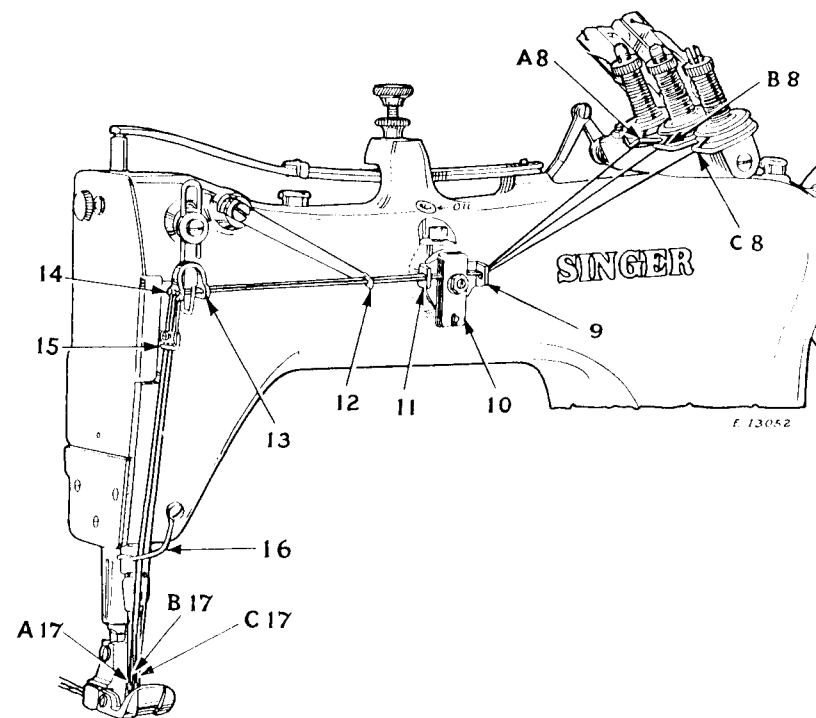

Fig. 8

Threading the Loopers

Turn the balance wheel until the needle bar is at its lowest position to bring the loopers into position for threading. Swing open the cover plates at the right of the throat plate and on the front and top of the horizontal arm

TO THREAD THE FRONT LOOPER (nearest operator), bring the thread from the spool (F1, Fig. 6) on the unwinder, down through

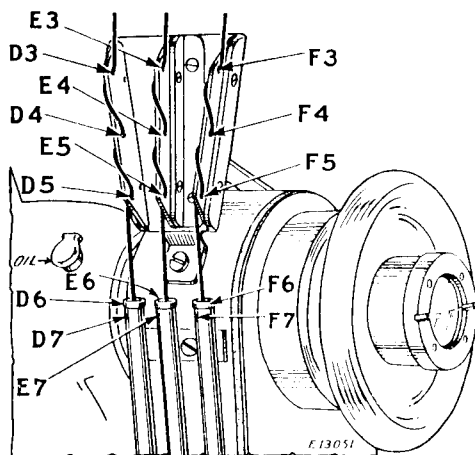

Fig. 9

the hole (F2) in the thread guide bar, then downward through each of the eyelets (F3, F4 and F5, Fig. 9) in the thread straightener as shown. Pass the thread through the ferrule at the end of the

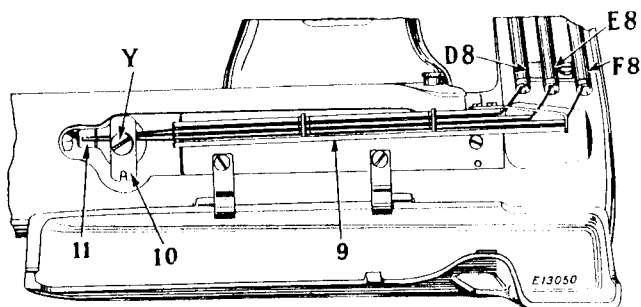

Fig. 10

thread tube (F6) and out through the hole at (F7), then pass it from the hole at (F8, Fig. 10) down through the lower ferrule of the thread tube, as shown in Fig. 10. The thread will automatically slip through the spiral slot into the tube. Then pass the

thread along the lower slot and in back of the three pins of the looper thread guide (9) as shown in Fig. 10, between the first and second plates of the looper thread tension (10), through the front eyelet of the guide (11), through the hole in the casting

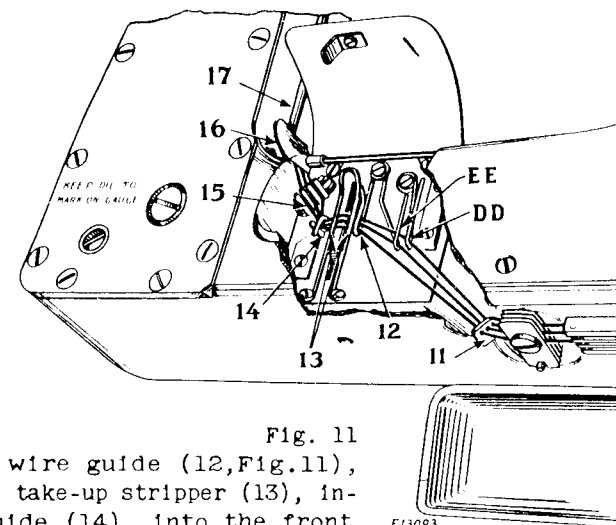

Fig. 11

into the wire guide (12, Fig. 11), under the take-up stripper (13), into the guide (14), into the front slot of the thread separator (15) and under the wire guard, down behind the thread retaining plate (16), through the thread tube (17), through the front hole

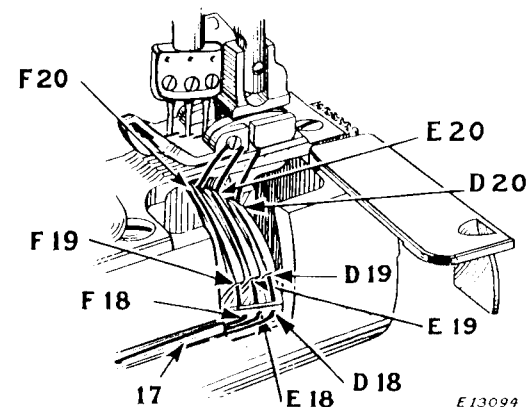

Fig. 12

(F18, Fig. 12) in the looper thread guide, through the hole (F19) in the heel of the front looper, and from front to back through the eye (F20) of the looper.

TO THREAD THE CENTER LOOPER, bring the thread from the spool (E1, Fig. 6) on the unwinder, down through the hole (E2) in the thread guide bar, then downward through each of the eyelets (E3, E4 and E5, Fig. 9) in the thread straightener as shown. Pass the thread through the ferrule at the end of the thread tube (E6) and out through the hole at (E7), then pass it from the hole at (E8, Fig. 10) down through the lower ferrule of the thread tube, as shown in Fig. 10. The thread will automatically slip through the spiral slot into the tube. Then pass the thread along the center slot and in back of the three pins of the looper thread guide (9), as shown in Fig. 10, between the second and third plates of the looper thread tension (10), through the center eyelet of the guide (11), through the hole in the casting into the wire guide (EE, Fig. 11), through the wire guide (12), under the take-up stripper (13), into the guide (14), into the center slot of the thread separator (15) and under the wire guard, down behind the thread retaining plate (16), through the thread tube (17), through the center hole (E18, Fig. 12) in the looper thread guide, through the hole (E19) in the heel of the center looper, and from front to back through the eye (E20) of the looper.

TO THREAD THE REAR LOOPER, bring the thread from the spool (D1, Fig. 6) on the unwinder, down through the hole (D2) in the thread guide bar, then downward through each of the eyelets (D3, D4 and D5, Fig. 9) in the thread straightener as shown. Pass the thread through the ferrule at the end of the thread tube (D6) and out through the hole at (D7), then pass it from the hole at (D8, Fig. 10) down through the lower ferrule of the thread tube, as shown in Fig. 10. The thread will automatically slip through the spiral slot into the tube. Then pass the thread along the upper slot and in back of the three pins of the looper thread guide (9), as shown in Fig. 10, between the third and fourth plates of the looper thread tension (10), through the rear eyelet of the guide (11), through the hole in the casting into the wire guides (DD and EE, Fig. 11) through the wire guide (12), under the take-up stripper (13), into the guide (14), into the rear slot of the thread separator (15) and under the wire guard, down behind the thread retaining plate (16), through the thread tube (17), through the rear hole (D18, Fig. 12) in the looper thread guide, through the hole (D19) in the heel of the rear looper, and from front to back through the eye (D20) of the looper.

Draw about two inches of thread through the eye of each looper with which to commence sewing.

To Regulate the Pressure on the Material

The pressure of the presser foot on the material should be heavy enough so that the feed will move the work evenly. To in-

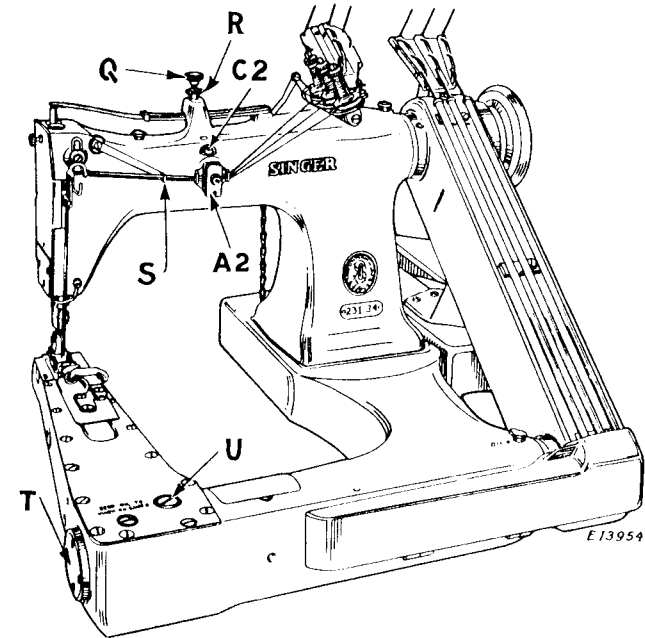

Fig. 13

crease the pressure, loosen the lock nut (R, Fig. 13) and turn the thumb screw (Q) downward. To decrease the pressure, turn the thumb screw (Q) upward. Then tighten the lock nut.

To Regulate the Tensions

The tension on the needle threads is regulated by the thumb nuts above the tension discs at the top of the machine. The needle threads require sufficient tension to set the stitch properly in the goods.

The tension on the looper threads is regulated by turning the screw (Y, Fig. 10) at the front of the looper thread tension plates to the right for more tension or to the left for less tension. The looper threads should have only enough tension to control the thread.

To Regulate the Length of Stitch

The length of the stitch is controlled by the feed eccentric, which may be adjusted by removing the screw plug (U, Fig. 13) in

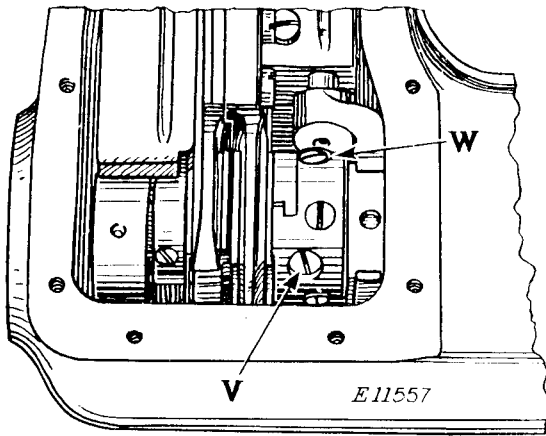

Fig. 14

the front end of the cylinder arm cover. First turn the balance wheel to bring the lock screw (V, Fig. 14) underneath the hole, and loosen this lock screw. Then turn the large screw (W) which projects beyond the body of the eccentric, to the left or outward for a longer stitch, or to the right for a shorter stitch. Tighten the lock screw (V) and replace the screw plug.

INSTRUCTIONS FOR ADJUSTERS AND MECHANICS

To Time and Set the Loopers in Relation to the Needles

The loopers should be at the end of their backward stroke, with the points farthest from the needles, at the same time that the needle bar is at its lowest point. In this position, the point of the front looper should be about 9/64 inch from the center of the front needle. The loopers may be moved to this position after loosening the clamping screw (CC, Fig. 15). The looper timing is set by having the first (when turning toward the operator) of the two set screws in the looper eccentric (S-2, Fig. 21) bear against a flat on the shaft.

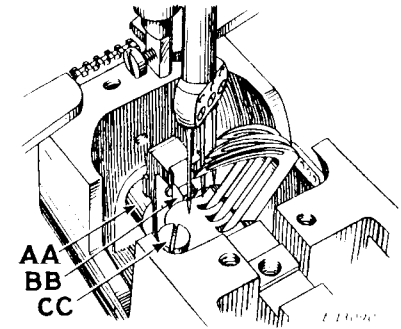

Fig. 15

If the belt has been removed or disturbed, the lower shaft must be timed by loosening the two set screws and the cap screw (E-2 and F-2, Fig. 20) in the lower belt pulley, and turning the lower shaft until the loopers are correctly timed with the needles. Tighten the cap screw (E-2) first, then the two set screws.

To Time the Needle-Avoiding Motion of the Loopers

The sidewise or needle-avoiding motion is produced by the eccentric at the right of the feed eccentric, on the lower shaft. The loopers should just clear the back of the needles on their forward stroke, and should clear the front of the needles on the backward stroke. A change in the timing of the eccentric will make the loopers come closer to or farther from the needles and therefore a different setting is required for different sizes of needles.

To adjust the eccentric, remove the cylinder arm cover and turn the balance wheel until one of the two set screws appears under the hole (V-2, Fig. 21). Loosen this screw about a quarter-turn, leaving it below the surface of the eccentric so that it will not score the inside of the bearing. Bring the other set screw under the hole, loosen it and leave the screwdriver in the slot to hold the eccentric while turning the shaft to obtain the desired adjustment.

To bring the loopers the same distance from the needles on their forward and backward strokes, they may be moved sideways on the looper shaft after loosening clamping screw (CC, Fig. 15).

To Set the Needle Guard

The function of the needle guard (BB, Fig. 15) is to prevent the needles springing into the path of the loopers when the loopers are on their forward stroke. The needle guard should be set as close as possible to the needles without touching them. To set the needle guard, loosen the set screw (FF, Fig. 16) underneath the end of the cylinder arm and move the needle guard to the correct position.

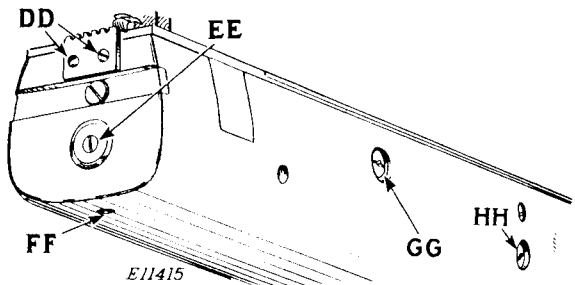

Fig. 16

To Set the Feed Dog at the Correct Height

When the feed dog is at its highest position practically the full depth of the teeth should project through the slots in the throat plate. The feed dog may be raised or lowered by turning the eccentric pin (GG, Fig. 16) a part of a turn in either direction. It is not necessary to lock this eccentric pin, as the necessary friction is provided by pressure of a set screw and lock nut inside the bed.

Thread Cutter

To remove the thread cutter blade for honing, take out the two screws (DD, Fig. 16).

To Set the Needle Bar

When the points of the loopers reach the centers of the needles on the upward stroke of the needle bar, the eyes of the needles should be about 1/8 inch below the looper points, so that the eyes of the needles and the eyes of the loopers will be in

perfect alignment when they pass each other.

The needle bar may be raised or lowered after loosening the clamping screw (MM, Fig. 17).

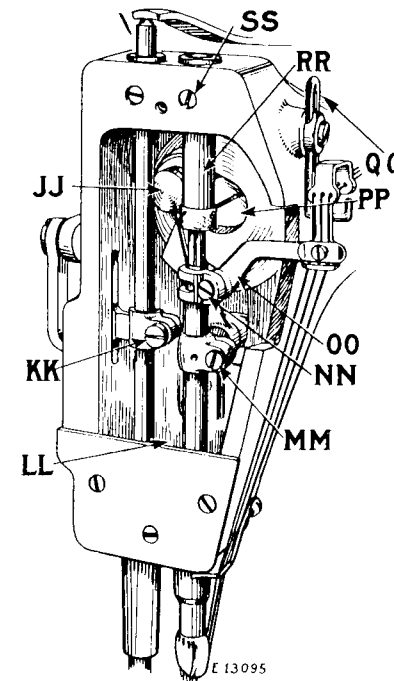

Fig. 17

To Set the Needle Thread Take-up

The needle thread take-up (OO, Fig. 17) is usually set so that the top of its clamp is about 1/16 inch below the top of the needle bar.

Adjustment of the Auxiliary Thread Take-up

The auxiliary thread take-up (QQ, Fig. 17) at the front of the machine should be set high enough so that it takes up the slack of the needle threads after the loopers have shed the needle loops and as the needle bar finishes its downward stroke and the stitch is set.

For some threads it will be necessary to set the auxiliary thread take-up at a height different from that required by others, owing to the differences in finish, twist, elasticity, etc.

To Adjust the Slack Thread Regulator

The slack thread regulator (S, Fig. 13) should be set so that when the loopers are shedding the needle loops on their backward stroke, the thread will not snap off the points of the loopers nor be drawn through the tension discs with enough tension to break the thread.

To set the slack thread regulator, it is best to start it in a low position and continue raising it until the loopers back out of the needle loops with a little tension on the thread.

To make this adjustment, loosen the clamping screw (B2, Fig. 2) and raise or lower the slack thread regulator as may be required, then securely tighten the clamping screw (B2).

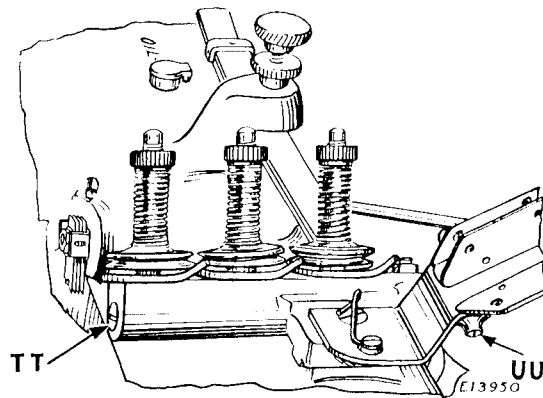

Fig. 18

To Adjust the Needle Thread Tension Releaser

The function of the needle thread tension releaser is to release the tension on the needle threads when the presser foot is raised. If the tension releaser does not release the threads when the presser foot is raised, or if the tension is partially released when the presser foot is down, loosen the set screw (UU, Fig. 18) and turn the shaft (TT) to the right or left until the correct adjustment is obtained, then tighten the set screw.

To Adjust the Needle Thread Nipper

The automatic thread nipper (A2, Fig. 13) at the front of the machine makes it possible to set the stitch tightly without using a heavy tension on the needle threads.

The nipper plates should open wide enough to allow the thread to pass freely between the plates, and should close and nip the

thread immediately after the loopers have cast off the needle loops on the downward stroke of the needle bar. To adjust the nipper, loosen the set screw (C2, Fig. 13) in the arm above the nipper plates and slide the nipper body inward or away from you for a greater opening of the plates, or outward for a smaller opening and earlier closing of the plates. When the desired adjustment is obtained, tighten the set screw (C2).

To Time the Looper Thread Take-up

The straight part of the take-up (VV, Fig. 19) should touch the thread between the take-up stripper wires (WW) just as the loopers

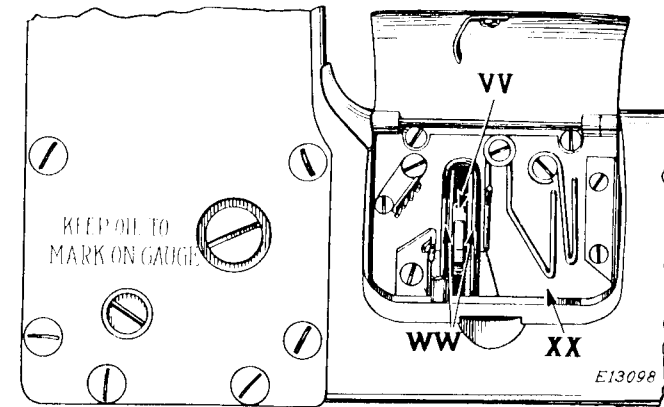

Fig. 19

start their backward or loop-shedding motion. The take-up acts also as a thread pull-off and should draw most of the thread through the tension discs on the backward stroke of the loopers, so that the loopers on their forward stroke will just draw the thread taut or pull a small amount of thread.

The take-up may be advanced to draw more thread during the back stroke, or retarded to draw less thread, after loosening the set screw in the hub of the take-up.

To Time the Feed

The set screw (T-2, Fig. 21) in the feed eccentric should bear against the flat on the shaft.

The feed lifting eccentric is connected to the looper eccentric and is timed as instructed on page 17.

To Remove and Replace the Arm Shaft Connection Belt

Remove the needles to prevent damage while the needles and loopers are out of time. Unscrew the balance wheel oil reservoir from the shaft. Loosen the two set screws in the balance wheel belt groove, and remove the balance wheel. Take out the two screws which hold the belt guard cover and remove the cover. The belt may be easily slipped off the lower belt pulley, then the upper pulley.

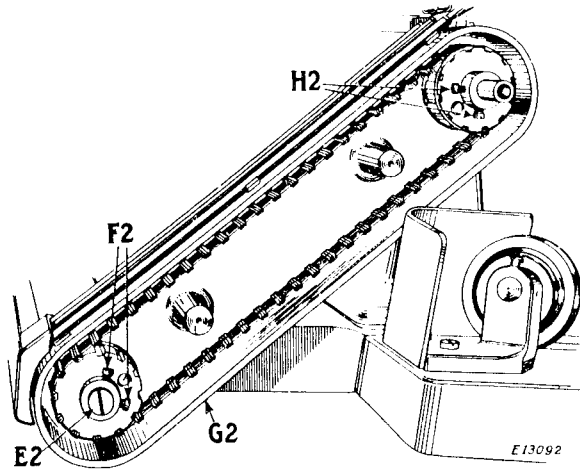

Fig. 20

When replacing the belt, first place it over the upper pulley, having the needle bar at its highest position. Turn the lower pulley until the feed dog is up and the loopers all the way forward. Keeping the pulleys in time with each other, place the belt on the lower pulley.

If the upper pulley is removed or disturbed, it should be reset as follows when replacing the belt. Turn one of the set screws (H-2, Fig. 20) lightly into the groove in the arm shaft, then place the belt on the pulleys and hang the belt guard cover over the shaft. Place the balance wheel on the shaft and turn one of the set screws in the belt groove lightly into the groove in the shaft. Insert and tighten the arm shaft oil reservoir to draw the pulley against the ball bearing. Tighten the two set screws (H-2) in the upper pulley and also those in the belt groove of the balance wheel. The belt guard cover may be swung out of the way without removing the balance wheel, in order to reach the lower pulley for timing the lower shaft.

To Remove the Arm Shaft

(See Fig. 17)

Remove face plate, presser foot and needles. Remove the balance wheel, belt guard cover and belt, as instructed on page 22. Remove the upper belt pulley. Loosen the presser bar lifter bracket clamp screw (KK, Fig. 17) and withdraw the presser bar from the top. Loosen clamp screws (MM and NN), remove the thread take-up and allow the needle bar to drop downward. Loosen set screw (SS) and tap the needle bar guide pin (RR) out through the top. Then tap the shaft out through the needle bar end, with the crank, oil retainer ring and ball bearing.

TO REMOVE ONLY THE ARM SHAFT CRANK, lower the needle bar and remove the presser bar as instructed above, take out the large cap screw (PP, Fig. 17) in the crank, and loosen the two large set screws in its perimeter which are accessible through the hole in the rear of the casting. The smaller screw which is also visible through the hole in the casting should not be molested. The crank may then be removed from the shaft.

When replacing the arm shaft crank, it is important to have the pin (JJ) opposite the oil hole in the shaft, in which position the two set screws will be opposite flats on the shaft. Turn the set screws loosely against the flats, tighten the large cap screw (PP), then tighten the set screws.

To Replace the Wicking in the Needle Bar Link Hinge Stud

The supply of oil in the reservoir at the center of the balance wheel should ordinarily last for about two days before it goes below the center of the hole in the shaft. If too much oil is lost into the well around the needle bar, a longer piece of wicking should be packed in the needle bar link pin in the arm shaft crank.

Remove the presser bar and drop the needle bar as instructed above, then remove the needle bar link. The wick may be replaced without removing the arm shaft crank.

To Remove the Lower Rotary Shaft

Remove the arm shaft connection belt, the belt pulleys and the belt guard (G-2, Fig. 20). Remove the looper thread guide at the front of the bed, and loosen the set screw underneath it which holds the right ball bearing case. Remove the take-up stripper plate (XX, Fig. 19) and loosen the set screw in the take-up (VV, Fig. 19). Loosen the two set screws in the intermediate

ball bearing hub, which is just to the left of the take-up. Loosen one of the set screws in the looper avoiding-motion eccentric (V-2, Fig. 21), but do not back the screw out far enough to score the bearing when the shaft is turned to bring the other set screw under the hole. Back out the second screw into the hole in the sleeve to hold the eccentric in position when the shaft is removed. Loosen the two set screws (T-2 and U-2) in the feed eccentric, also the two set screws in the feed lifting and looper motion eccentric (S-2). Remove the plate (T, Fig. 13) and take out the cap screw at the left end of the shaft. Withdraw the shaft, with the right bearing case, from the pulley end.

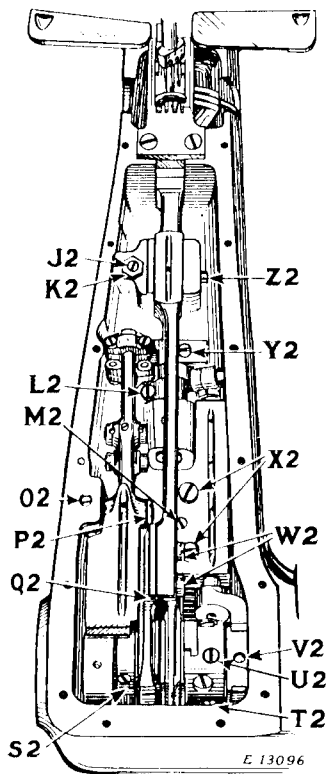

Fig. 21

To Remove the Feed Bar

Remove the presser foot, throat plate and feed dog. Loosen nut (K-2, Fig. 21) and back out the friction screw (J-2) until the eccentric pin (Z-2) can be pushed out. Swing the feed bar upright and take out the two screws (W-2). Slide the feed lifting fork (Q-2) upward and off, then lower the feed bar to a horizontal position and lift it off the eccentric block.

To Remove the Looper Mechanism

Loosen screws (EE and FF, Fig. 16), remove the needle guard and the needle guard holder (AA, Fig. 15). Loosen the clamping screw (CC, Fig. 15) and remove the looper holder from the looper shaft. Loosen the clamping screws (L-2 and Y-2, Fig. 21) in the looper driving arm and the adjustable collar. The looper shaft may be withdrawn through the needle guard holder opening at the looper end of the bed.

To remove the looper driving mechanism complete, first remove the lower rotary shaft. Loosen the set screw (O2, Fig. 21) and drive out the top pin (P2). Loosen the two set screws in the collar directly under the pin (P2), and the set screw (M2), then unscrew the lower pin (HH, Fig. 16). The entire assembly may now be lifted out.

Remove the two screws (X-2) and lift out the block with the looper avoiding-motion shaft and fork.

Genuine Singer Needles should be used
in Singer Machines.
These Needles and their Containers
are marked with the
Company's Trade Mark "SIMANCO." 1

Needles in Containers marked
"For Singer Machines"
are not Singer made needles. 2