

BAS-511

Automatic Lock Stitch Button Holer



Specifications

| | | | |
|-------------------------|---|--|--|
| Machine head | LH4-B816NP (Lockstitch button holer <clutch-less type>) | | |
| Sewing speed | 4,000 rpm (Normally 3,600 rpm) | | |
| Feed mechanism | Clamp feeding by DC motor drive | | |
| Height of stepping foot | 10 mm | | |
| Button-hole width | 2 - 4.6 mm | | |
| Button-hole length | 11 - 22 mm | | |
| No. of holes | 2-20 pcs. | | |
| Max. number of stitches | 58 - 347 | | |
| Size | A | 55 - 399 mm (Settings can be made within a range of 45 - 389 mm.) | |
| | B | 7-20 mm | |
| | C | 150-600 mm when the standby feature is not used 150-1,150 mm when the standby feature is used | |
| | D | 25-600 mm | |
| | E | 45 mm or more | |
| | L | 350-1,400 mm | |
| | W | 200-400 mm | |
| No. of memory patterns | 20 patterns | | |
| Minimum feeding | 1 mm | | |
| Safety device | Lower thread waning by means of the lower thread counter Inoperable cutter due to upper thread cutting | | |
| Air pressure | 0.5 Mpa 10 l / min | | |
| Power source | Three phase : 220 V, 380 V, 415 V 600 VA | | |
| Machine dimensions | 2,040(L) × 760(W) × 1,900(H)mm | | |
| Weight | 220 kg | | |

GAUGE PARTS LIST

Change gear

| Number of stitches | Change gear L | Change gear R | Number of stitches | Change gear L | Change gear R |
|--------------------|-----------------|-----------------|--------------------|-----------------|-----------------|
| 347 | (54) 141388-000 | (22) 141372-001 | 127 | (36) 141379-000 | (40) 141381-000 |
| 306 | (52) 141387-000 | (24) 141373-001 | 114 | (34) 141378-000 | (42) 141382-000 |
| 271 | (50) 141386-000 | (26) 141374-000 | 103 | (32) 141377-000 | (44) 141383-000 |
| 242 | (48) 141385-000 | (28) 141375-000 | 92 | (30) 141376-000 | (46) 141384-000 |
| 216 | (46) 141384-000 | (30) 141376-000 | 82 | (28) 141375-000 | (48) 141385-000 |
| 194 | (44) 141383-000 | (32) 141377-000 | 73 | (26) 141374-000 | (50) 141386-000 |
| 174 | (42) 141382-000 | (34) 141378-000 | 65 | (24) 141373-001 | (52) 141387-000 |
| 157 | (40) 141381-000 | (36) 141379-000 | 58 | (22) 141372-001 | (54) 141388-000 |
| 141 | (38) 141380-000 | (38) 141380-000 | | | |

Needle plate

| 1.2mm S | S01269-001 | 1.4mm S | 159759-001 | 1.2mm L | S01963-001 |
|--|---|-----------------------------|------------|---------|------------|
| <p>For needle #80 (#12)</p> | <p>For needle #90 (#14)</p> | <p>For needle #80 (#12)</p> | | | |
| 1.4mm L | S01964-001 | Plastic plate | S01270-001 | | |
| <p>Standard part</p> <p>For needle #90 (#14)</p> | <p>For needle plate 1.2mm S <For flat cutter></p> | | | | |

Base plate

| S19861-001 | S19809-001 |
|---|----------------------|
| <p>For needle plate 1.2mm S <For flat cutter></p> | <p>Standard part</p> |

Cutter

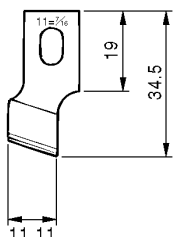
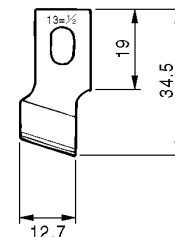
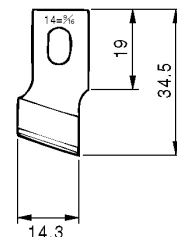
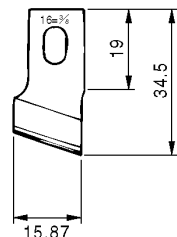
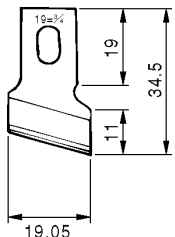
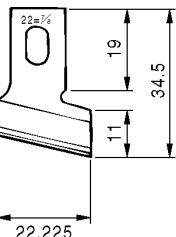
| 7/16 | 1/2 | 9/16 | 5/8 | 3/4 | 7/8 |
|---|---|---|---|---|---|
| 107204-001 | 107200-001 Standard part | S03278-001 | 107205-001 | 107207-001 | 109838-001 |
|  |  |  |  |  |  |
| 7/16 | 1/2 | 9/16 | 5/8 | 3/4 | 7/8 |

Upper claming foot assy

Upper claming foot

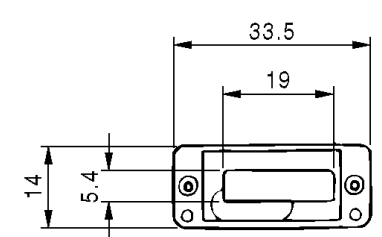
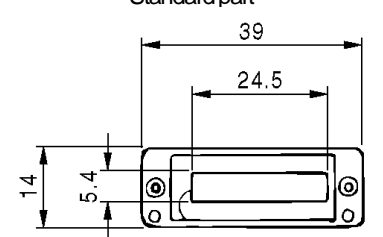
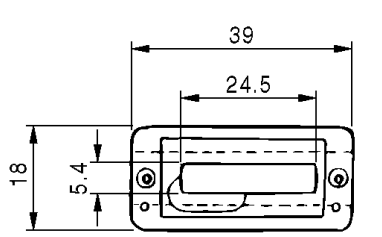
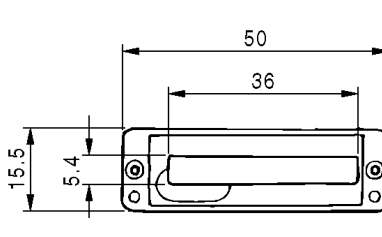
| 12.7mm R | S03291-101 S03292-001 | 16mm R | 158982-101 159581-001 | 16mm RS | 159764-101 159761-001 |
|--|-----------------------------|--------|---|---|--------------------------|
|  | Standard part | |  |  | |
| Finger guard SS (S00660-000) | Finger guard S (159079-000) | | Finger guard S (159079-000) | | |
| 25mm R | 159217-101 159582-001 | | | | |
|  | | | | | |
| Finger guard M (159080-000) | | | | | |

Gauge

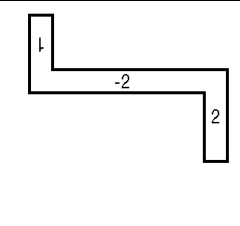
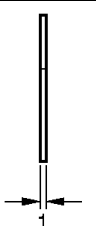
| Gauge 815-2 | S13595-001 |
|---|---|
|  |  |
| For needle plate 1.2mm S & 1.4mm S | |

Option parts

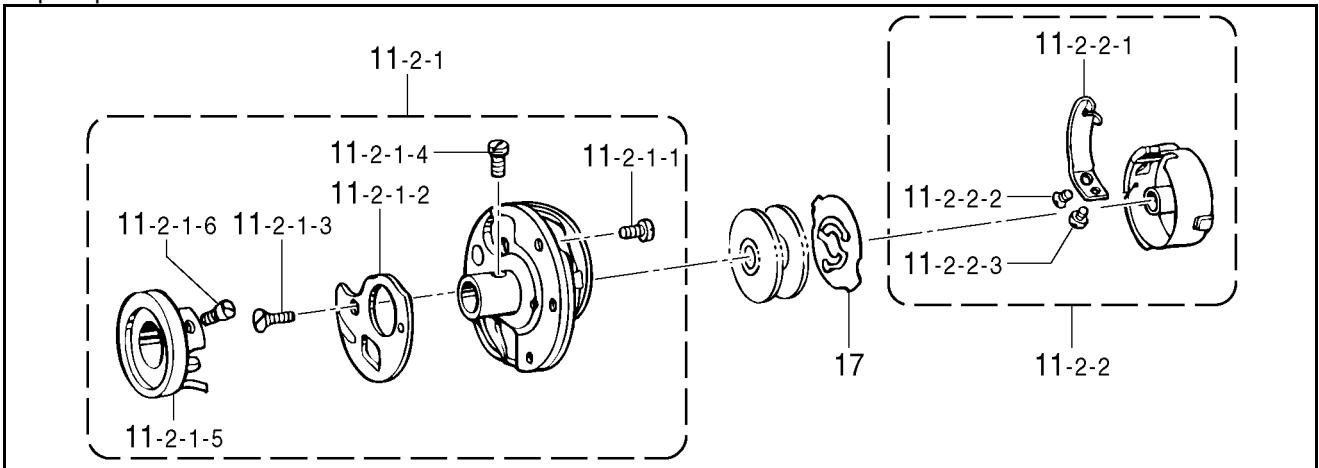

| Ref. No. | Part name | Part code | Q'ty |
|----------|------------------------------|------------|------|
| 11-2 | Rotary hook bobbin case assy | S19899-001 | 1 |
| 11-2-1 | Rotary hook assy | S19897-001 | 1 |
| 11-2-1-1 | Screw | 183526-001 | 3 |
| 11-2-1-2 | Rotary hook rear plate | 183596-001 | 1 |
| 11-2-1-3 | Screw | 183598-001 | 1 |
| 11-2-1-4 | Outer rotary hook set screw | 183490-001 | 2 |
| 11-2-1-5 | Ring | S19894-001 | 1 |
| 11-2-1-6 | Set screw | S20014-001 | 2 |
| 11-2-2 | Bobbin case assy (P) | S01870-001 | 1 |
| 11-2-2-1 | Spring | S09477-001 | 1 |
| 11-2-2-2 | Screw | 180721-001 | 1 |
| 11-2-2-3 | Adjust screw | 183507-001 | 1 |
| 17 | Spring | S01109-001 | 1 |

* The above parts are only for purl stitches. (Bobbin case hole : 1)