

# BAS-511

## Automatic Lock Stitch Button Holer



### Specifications

Machine head	LH4-B816NP (Lockstitch button holer <clutch-less type>)		
Sewing speed	4,000 rpm ( Normally 3,600 rpm)		
Feed mechanism	Clamp feeding by DC motor drive		
Height of stepping foot	10 mm		
Button-hole width	2 - 4.6 mm		
Button-hole length	11 - 22 mm		
No. of holes	2-20 pcs.		
Max. number of stitches	58 - 347		
Size	A	55 - 399 mm (Settings can be made within a range of 45 - 389 mm.)	
	B	7-20 mm	
	C	150-600 mm when the standby feature is not used 150-1,150 mm when the standby feature is used	
	D	25-600 mm	
	E	45 mm or more	
	L	350-1,400 mm	
	W	200-400 mm	
No. of memory patterns	20 patterns		
Minimum feeding	1 mm		
Safety device	Lower thread waning by means of the lower thread counter Inoperable cutter due to upper thread cutting		
Air pressure	0.5 Mpa 10 l / min		
Power source	Three phase : 220 V, 380 V, 415 V 600 VA		
Machine dimensions	2,040(L) × 760(W) × 1,900(H)mm		
Weight	220 kg		

# GAUGE PARTS LIST

## Change gear

Number of stitches	Change gear L	Change gear R	Number of stitches	Change gear L	Change gear R
347	(54) 141388-000	(22) 141372-001	127	(36) 141379-000	(40) 141381-000
306	(52) 141387-000	(24) 141373-001	114	(34) 141378-000	(42) 141382-000
271	(50) 141386-000	(26) 141374-000	103	(32) 141377-000	(44) 141383-000
242	(48) 141385-000	(28) 141375-000	92	(30) 141376-000	(46) 141384-000
216	(46) 141384-000	(30) 141376-000	82	(28) 141375-000	(48) 141385-000
194	(44) 141383-000	(32) 141377-000	73	(26) 141374-000	(50) 141386-000
174	(42) 141382-000	(34) 141378-000	65	(24) 141373-001	(52) 141387-000
157	(40) 141381-000	(36) 141379-000	58	(22) 141372-001	(54) 141388-000
141	(38) 141380-000	(38) 141380-000			

## Needle plate

1.2mm S	S01269-001	1.4mm S	159759-001	1.2mm L	S01963-001
<p>For needle #80 (#12)</p>		<p>For needle #90 (#14)</p>		<p>For needle #80 (#12)</p>	
1.4mm L	S01964-001	Plastic plate	S01270-001		
<p>Standard part</p> <p>For needle #90 (#14)</p>		<p>For needle plate 1.2mm S &lt;For flat cutter&gt;</p>			

## Base plate

S19861-001	S19809-001
<p>For needle plate 1.2mm S &lt;For flat cutter&gt;</p>	<p>Standard part</p>

Cutter

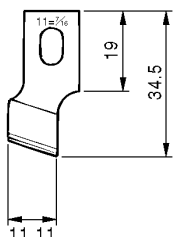
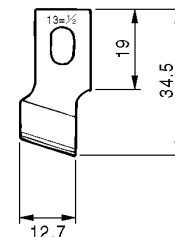
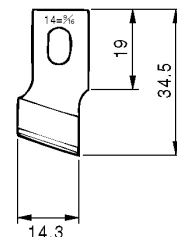
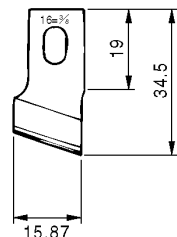
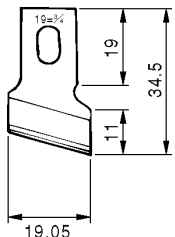
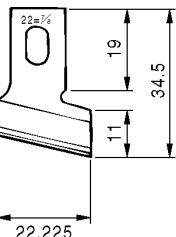
7/16	1/2	9/16	5/8	3/4	7/8
107204-001	107200-001 Standard part	S03278-001	107205-001	107207-001	109838-001
					
<b>7/16</b>	<b>1/2</b>	<b>9/16</b>	<b>5/8</b>	<b>3/4</b>	<b>7/8</b>

Upper claming foot assy

Upper claming foot

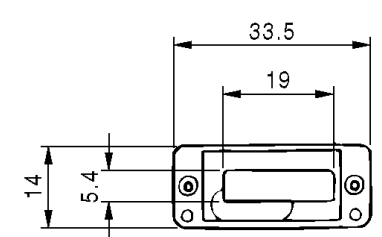
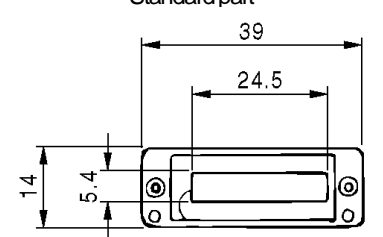
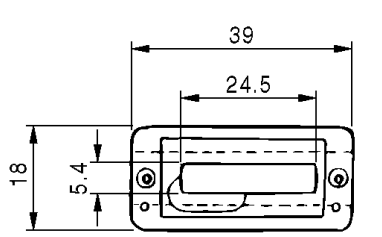
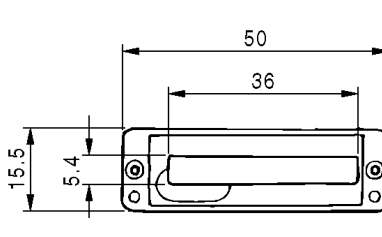
12.7mm R	S03291-101 S03292-001	16mm R	158982-101 159581-001	16mm RS	159764-101 159761-001
	Standard part				
Finger guard SS (S00660-000)	Finger guard S (159079-000)		Finger guard S (159079-000)		
25mm R	159217-101 159582-001				
	Finger guard M (159080-000)				

Gauge

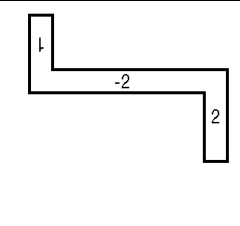
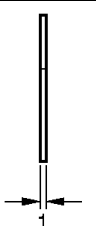
Gauge 815-2	S13595-001
	
For needle plate 1.2mm S & 1.4mm S	

Option parts

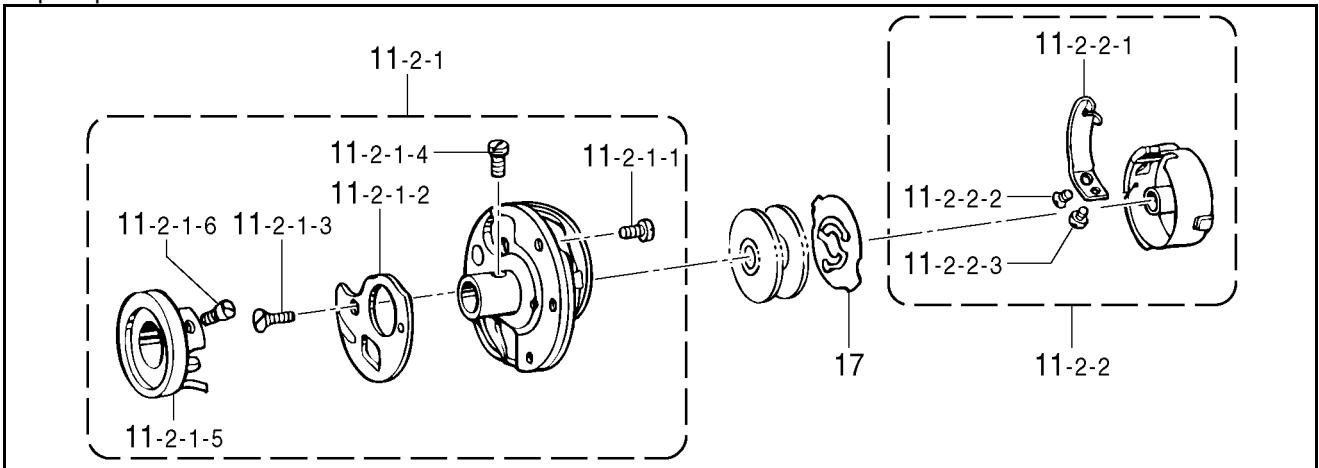

Ref. No.	Part name	Part code	Q'ty
11-2	Rotary hook bobbin case assy	S19899-001	1
11-2-1	Rotary hook assy	S19897-001	1
11-2-1-1	Screw	183526-001	3
11-2-1-2	Rotary hook rear plate	183596-001	1
11-2-1-3	Screw	183598-001	1
11-2-1-4	Outer rotary hook set screw	183490-001	2
11-2-1-5	Ring	S19894-001	1
11-2-1-6	Set screw	S20014-001	2
11-2-2	Bobbin case assy (P)	S01870-001	1
11-2-2-1	Spring	S09477-001	1
11-2-2-2	Screw	180721-001	1
11-2-2-3	Adjust screw	183507-001	1
17	Spring	S01109-001	1

\* The above parts are only for purl stitches. (Bobbin case hole : 1)