

Please read this manual before using the machine.
Please keep this manual within easy reach for quick reference.

AUTOMATIC POCKET SETTER <JEANS>

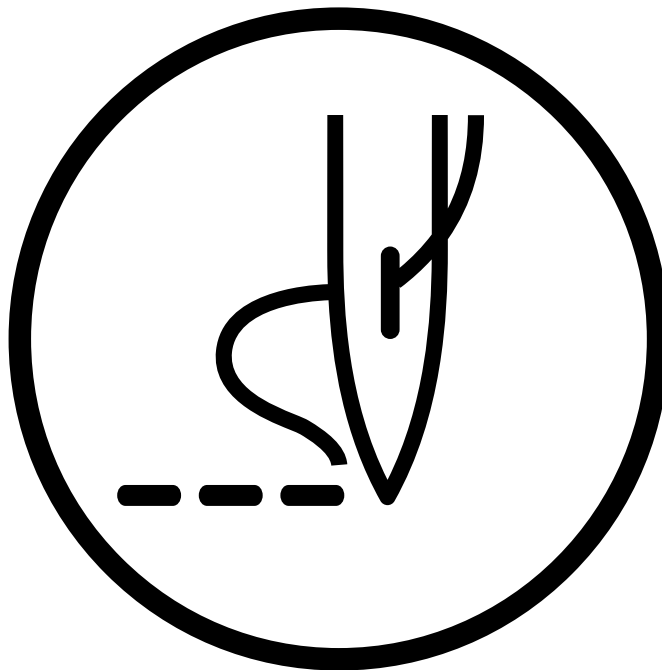

Thank you very much for buying a BROTHER sewing machine. Before using your new machine, please read the safety instructions below and the explanations given in the instruction manual.



With industrial sewing machines, it is normal to carry out work while positioned directly in front of moving parts such as the needle and thread take-up lever, and consequently there is always a danger of injury that can be caused by these parts. Follow the instructions from training personnel and instructors regarding safe and correct operation before operating the machine so that you will know how to use the machine correctly.

SAFETY INSTRUCTIONS

1 Safety indications and their meanings

This instruction manual and the indications and symbols that are used on the machine itself are provided in order to ensure safe operation of this machine and to prevent accidents and injury to yourself or other people. The meanings of these indications and symbols are given below.

Indications

 DANGER	<p>The instructions which follow this term indicate situations where failure to follow the instructions will almost certainly result in death or severe injury.</p>
 CAUTION	<p>The instructions which follow this term indicate situations where failure to follow the instructions could cause injury when using the machine or physical damage to equipment and surroundings.</p>

Symbols



..... This symbol (△) indicates something that you should be careful of. The picture inside the triangle indicates the nature of the caution that must be taken.
(For example, the symbol at left means "beware of injury".)



..... This symbol (⊘) indicates something that you must not do.



..... This symbol (●) indicates something that you must do. The picture inside the circle indicates the nature of the thing that must be done.
(For example, the symbol at left means "you must make the ground connection".)

2 Notes on safety

DANGER











Wait at least 5 minutes after turning off the power switch and disconnecting the power cord from the wall outlet before opening the face plate of the control box.

Touching areas where high voltages are present can result in severe injury.





CAUTION



Installation

-  Machine installation should only be carried out by a qualified technician.
-  Contact your Brother dealer or a qualified electrician for any electrical work that may need to be done.
-  The sewing machine weighs more than 400 kg. The installation should be carried out by two or more people.
-  Do not connect the power cord until installation is complete, otherwise the machine may operate if the start switch is pressed by mistake, which could result in injury.
-  Be sure to connect the ground. If the ground connection is not secure, you run the risk of receiving a serious electric shock.

-  Be sure to wear protective goggles and gloves when handling the lubricating oil and grease, so that they do not get into your eyes or onto your skin, otherwise inflammation can result.
Furthermore, do not drink the oil or eat the grease under any circumstances, as they can cause vomiting and diarrhoea.
Keep the oil out of the reach of children.
-  Avoid setting up the sewing machine near sources of strong electrical noise such as high-frequency welding equipment.
If this precaution is not taken, incorrect machine operation may result.
-  Have two people present to hold the machine head with both their hands when tilting it back or returning it to its original position.

Sewing

-  This sewing machine should only be used by operators who have received the necessary training in safe use beforehand.
-  The sewing machine should not be used for any applications other than sewing.
-  Attach all safety devices before using the sewing machine.
If the machine is used without these devices attached, injury may result.
-  Turn off the power switch at the following times, otherwise the machine may operate if the start switch is pressed by mistake, which could result in injury.
 - When not using the machine
 - When leaving the machine unattended

-  Do not touch any of the moving parts or press any objects against the machine while sewing, as this may result in personal injury or damage to the machine.
-  If an error occurs in machine operation, or if abnormal noises or smells are noticed, immediately turn off the power switch. Then contact your nearest Brother dealer or a qualified technician.
-  If the machine develops a problem, contact your nearest Brother dealer or a qualified technician.

CAUTION

Cleaning

 Turn off the power switch before starting any cleaning work, otherwise the machine may operate if the start switch is pressed by mistake, which could result in injury.

 Be sure to wear protective goggles and gloves when handling the lubricating oil and grease, so that they do not get into your eyes or onto your skin otherwise inflammation can result.

Furthermore, do not drink the oil or eat the grease under any circumstances, as they can cause vomiting and diarrhoea.

Keep the oil out of the reach of children.

Maintenance and inspection

 Maintenance and inspection of the sewing machine should only be carried out by a qualified technician.

 Ask your Brother dealer or a qualified electrician to carry out any maintenance and inspection of the electrical system.

 Turn off the power switch and disconnect the power cord from the wall outlet at the following times, otherwise the machine may operate if the start switch is pressed by mistake, which could result in injury.

When carrying out inspection, adjustment and maintenance

When replacing consumable parts such as the rotary hook and knife

 Disconnect the air hoses from the air supply and wait for the needle on the pressure gauge to drop to "0" before carrying out inspection, adjustment and repair of any parts which use the pneumatic equipment.

 If the power switch and air need to be left on when carrying out some adjustment, be extremely careful to observe all safety precautions.

 Use only the proper replacement parts as specified by Brother.

 If any safety devices have been removed, be absolutely sure to re-install them to their original positions and check that they operate correctly before using the machine.

 Any problems in machine operation which result from unauthorized modifications to the machine will not be covered by the warranty.

 Have two people present to hold the machine head with both their hands when tilting it back or returning it to its original position.

3 Warning labels

The following warning labels appear on the sewing machine.

Please follow the instructions on the labels at all times when using the machine. If the labels have been removed or are difficult to read, please contact your nearest Brother dealer.

1

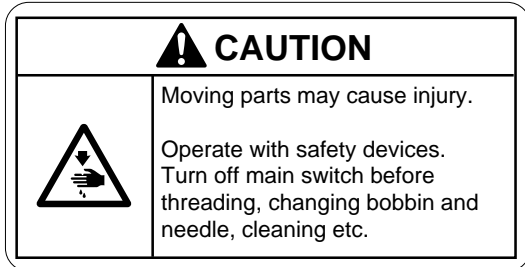

3

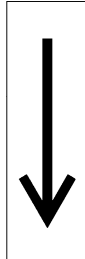

Safety devices: Thread take-up cover,
Guard bar, Belt cover, etc.

2

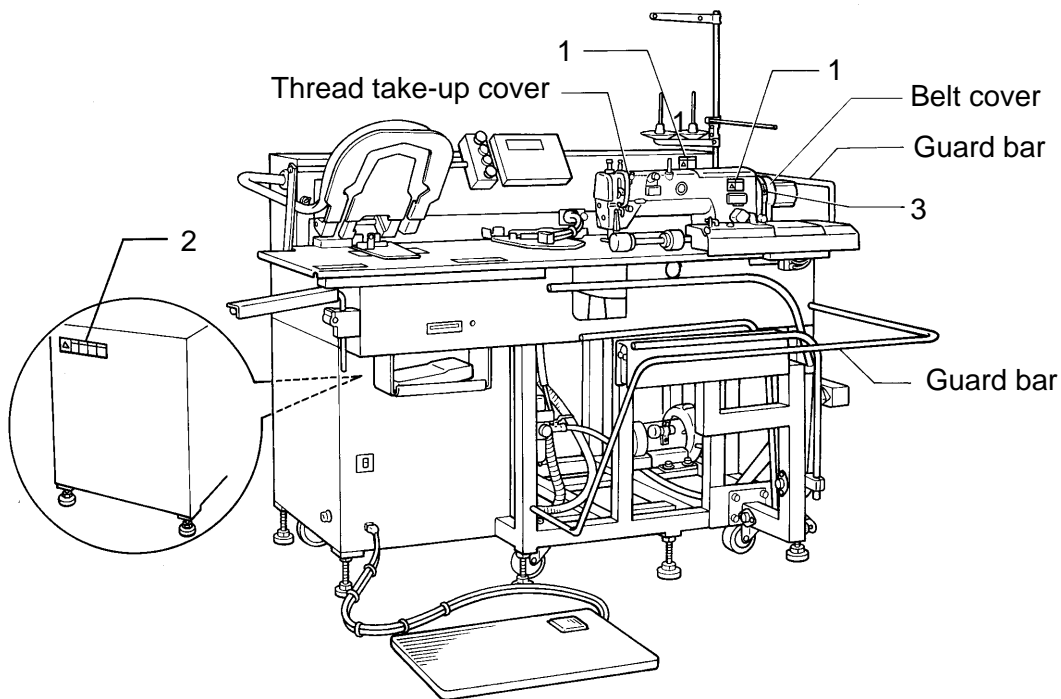
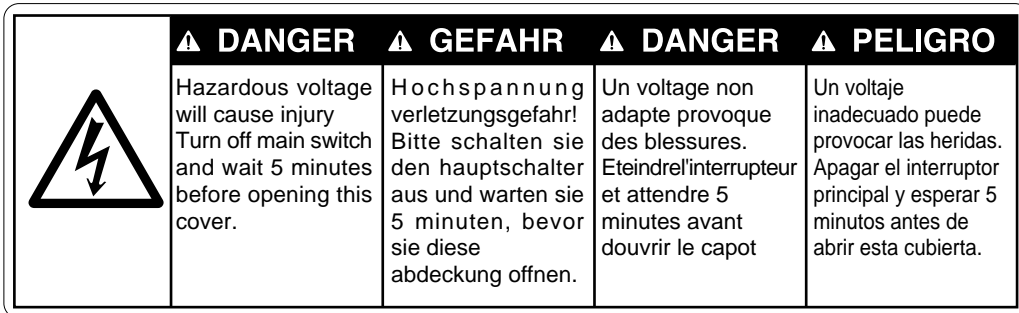

CONTENTS

1. Names of Machine Components	1
2. Specifications	2
3. Installation	3
3-1. Installation of the machine table	3
3-2. Removal of the fixing bolts from the machine	4
3-3. Installation of the spool stand	4
3-4. Connection of the foot-switch connector	5
3-5. Connection of the air hose	5
3-6. Positioning of the front supporter	5
3-7. Installation positions for operation box and switch box	6
3-8. Installation of the folding group assembly	7
4. Lubrication	8
5. Correct operation	9
5-1. Installing the needle	9
5-2. Upper threading	9
5-3. Bobbin case threading	10
5-4. Bobbin thread winding	11
5-5. Thread tension	12
6. Button functions	13
6-1. Operation box panel buttons	13
6-2. Switch box panel buttons	16
6-3. Foot switch	17
6-4. RESTART buttons	17
7. Setting before sewing	18
7-1. Setting the folder mode	18
7-2. Setting the sewing speed and the bar tacking speed	18
7-3. Setting the lower thread counter	20
7-4. Setting the piece counter	21
7-5. Setting the stacker roller feed amount	21
7-6. Setting the date and time	22
8. Preparation for sewing	23
9. Sewing	25
9-1. Sewing with the folder in automatic mode	25
9-2. Sewing with the folder in pattern matching mode	26
9-3. Sewing with the folder in label attachment mode	27
9-4. Sewing with the folder in step mode	28
9-5. Test feeding	29
9-6. Emergency stop	30
10. Standard adjustments	31
10-1. Needle-bar height adjustment	31
10-2. Needle and rotary hook timing	32
10-3. Presser foot height adjustment	32
10-4. Removal of the fixed knife and the movable knife	33
10-5. Stacker position adjustment	34
10-6. Sewing clamp assembly number selection	35
11. Using the DIP switches	36
12. Table of error code	38

1. Names of Machine Components

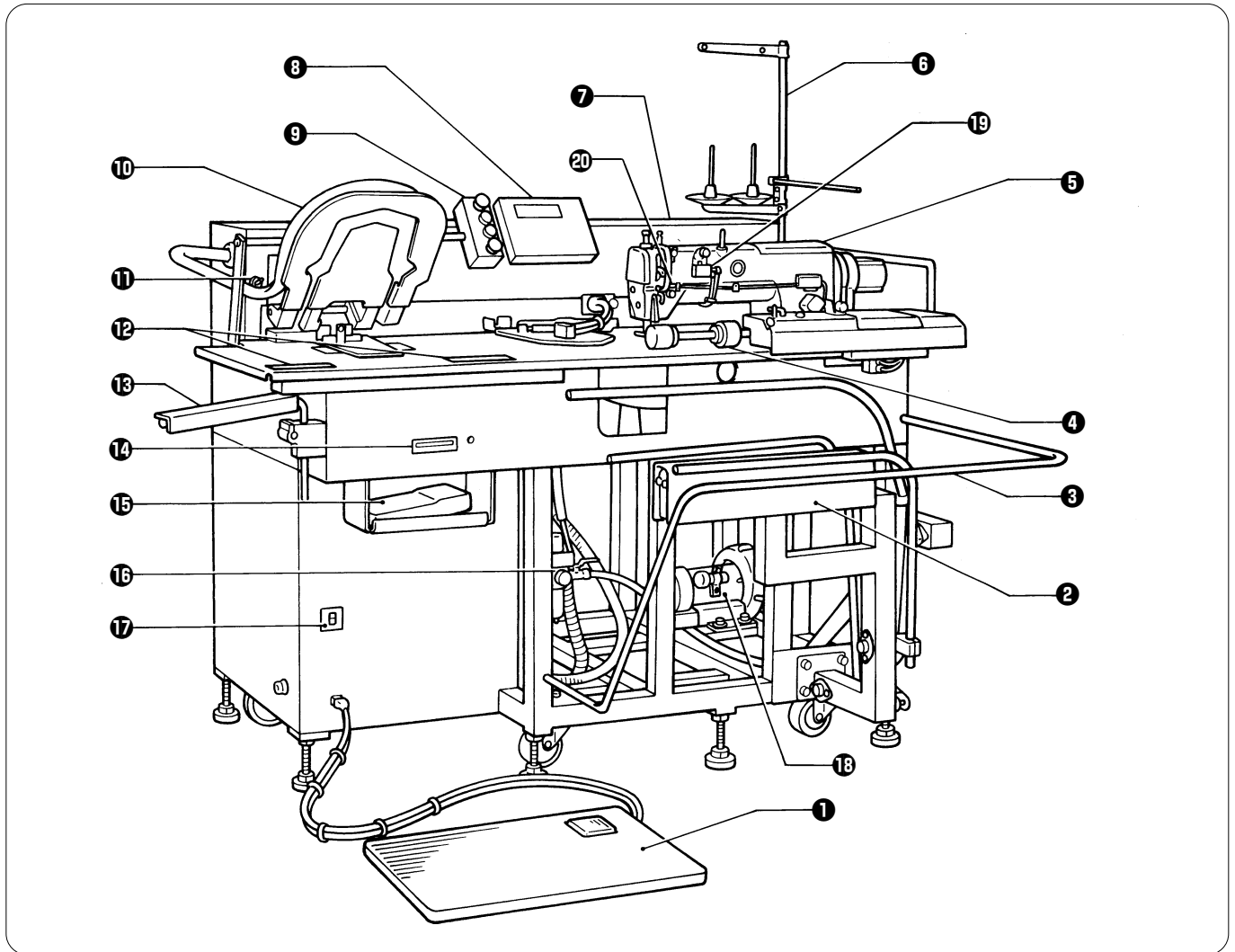











- | | | |
|--------------------------------|----------------------------|-------------------|
| ❶ Foot-switch | ❷ Stacker | ❸ Guard bar |
| ❹ Feed roller | ❺ Machine head | ❻ Spool stand |
| ❼ Top cover | ❽ Control box | ❼ Switch box |
| ❿ Folding group assembly | ⓫ Mechanical valve | ⓬ RESTART buttons |
| Ⓜ Front supporter | ⓮ Floppy drive | ⓯ Programmer |
| Ⓡ Air unit valve | Ⓡ Power switch | Ⓢ Blower Motor |
| Ⓣ 2-Step thread tension device | Ⓣ Thread breakage detector | |

2. Specifications

Applicable machine type	Lock stitch and special cross stitch sewing machine with automatic thread trimmer
Use	Sewing pockets on the various types of jeans
Cycle time	9 seconds approx. (depending on the pitch and rpm)
Sewing speed	500 – 4250rpm (9-step button selectable; limited by sewing condition)
Bar tacking speed	500 – 3500rpm (7-step button selectable; cannot exceed sewing speed)
Sewing range	250 (X) mm × 250 (Y) mm Standard (when not using retractable work clamp)
	250 (X) mm × 200 (Y) mm For retractable work clamp (restrictions may occur because of shape)
Sewing pitch	0.05 – 6.00mm
Needle racking width at first bar tacking	Maximum of 3.5 mm
Cloth setting	Overlapping possible
Machine head drive	AC servo direct motor type
Machine body drive	X-axis for a clamp shift, Y-axis for a machine shift, AC servo motor (750W).
Memory medium	3.5-2HD inch floppy disk
	64 patterns (Maximum of 1,000 stitches for each pattern)
Jig attaching/detaching method	Air chuck; one-touch operation requiring less than 2 minutes
Stacker	Included (Stacking capacity 60 pieces)
Programmer	Included
Power source	3-phase 200V, 220V, 380V, 400V, 415V (900W)
Air pressure	0.44 – 0.54MPa
Machine dimensions	(W) 2.108mm, (L) 1.919mm, (H) 970mm
Weight	400kg
Upper-thread breakage detector	Included
Label attachment device	Included (option)

3. Installation

 CAUTION	
<p> Machine installation should only be carried out by a qualified technician.</p> <p> Contact your Brother dealer or a qualified electrician for any electrical work that may need to be done.</p> <p> The sewing machine head weights more than 400 kg. The installation should be carried out by two or more people.</p> <p> Do not connect the power cord until installation is complete, otherwise the machine may operate if the foot switch is depressed by mistake, which could result in injury.</p> <p> Be sure to connect the ground. If the ground connection is not secure, you run the risk of receiving a serious electric shock.</p> <p> Do not place any objects on top of the top cover, otherwise such objects may fall down onto the machine. If you need to put something on top of the top cover, place it inside a box or similar to secure it so as to stop it from falling down.</p>	<p> Be sure to wear protective goggles and gloves when handling the lubricating oil and grease, so that they do not get into your eyes or onto your skin, otherwise inflammation can result. Furthermore, do not drink the oil or eat the grease under any circumstances, as they can cause vomiting and diarrhoea. Keep the oil out of the reach of children.</p> <p> Avoid setting up the sewing machine near sources of strong electrical noise such as high-frequency welding equipment. If this precaution is not taken, incorrect machine operation may result.</p> <p> Hold the machine head with both hands when tilting it back or returning it to its original position. Furthermore, after tilting back the machine head, do not push the face plate side or the pulley side from above, as this could cause the machine head to topple over, which may result in personal injury or damage to the machine.</p>

Note:

- This sewing machine has a movable machine head and work clamp. Be careful not to place other objects within the moving range of these parts.
- Supply power directly from a receptacle for the machine's exclusive use.
- Be sure to power off when installing.

3-1. Installation of the machine table

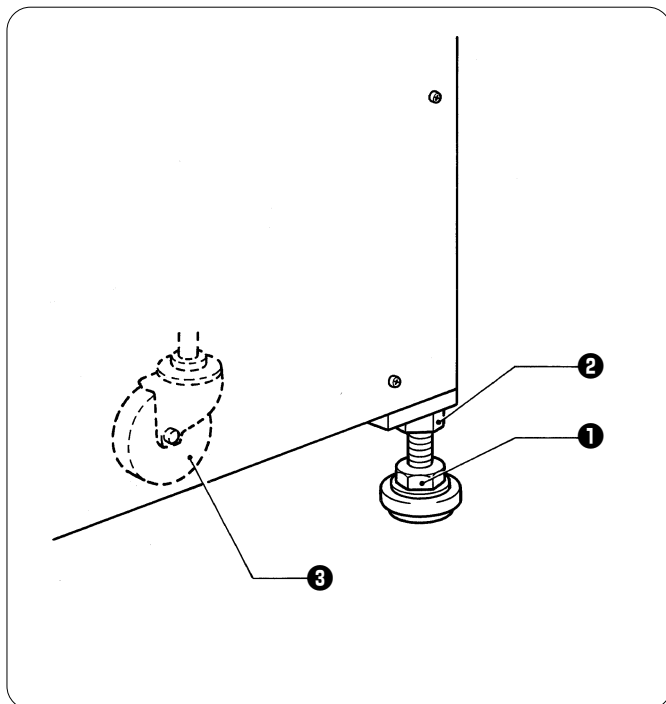

1. Secure the level adjusters **1** so that the table top remain level.
2. The table has eight level adjusters. If the table does not sit well, loosen nuts **2** and turn the level adjusters **1** to level the table.

Note:

There are eight adjusting points.

To move the machine, turn up adjusters **1**, and the table can be moved on its machine body casters **3**.

3-2. Removal of the fixing bolts from the machine

The machine head and the sewing clamp arm are fixed with bolts to secure them during transportation.

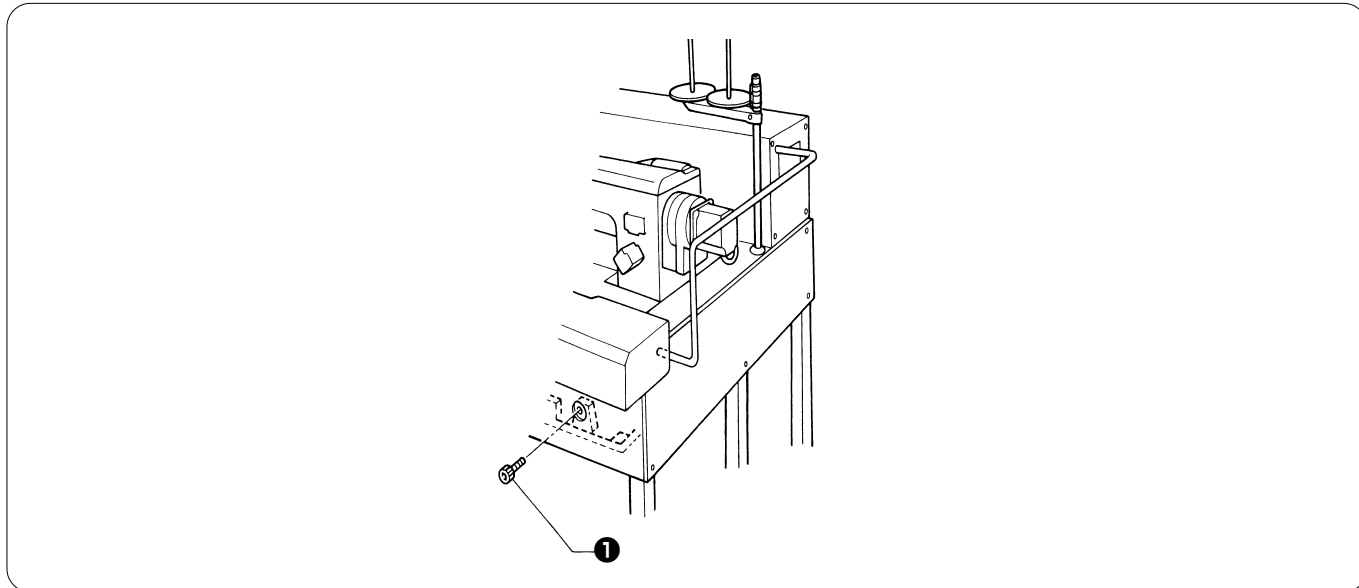

Remove fixing bolt ❶ on the machine head through the hole in the front cover.

Note:

- Save removed fixing bolts ❶ for future use.
- Before transporting the machine be sure to secure it with the fixing bolts.

3-3. Installation of the spool stand

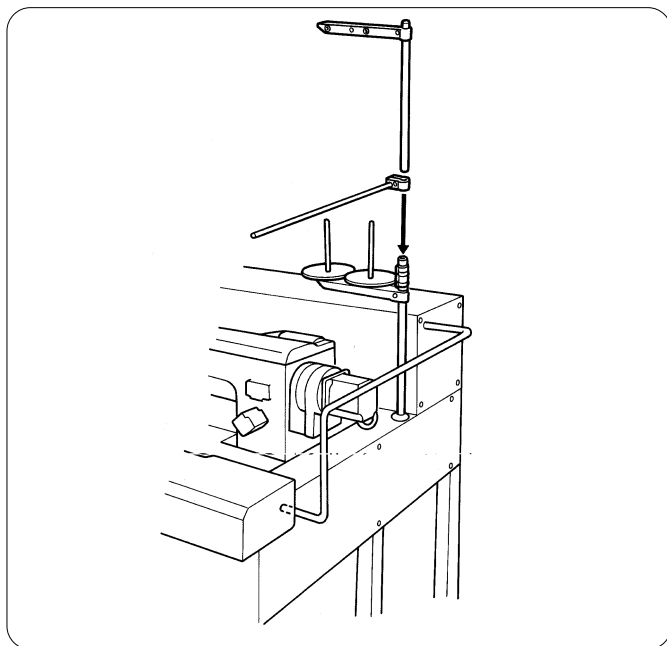

Install the spool stand as shown in the illustration at left.

3. Installation

3-4. Connection of the foot-switch connector

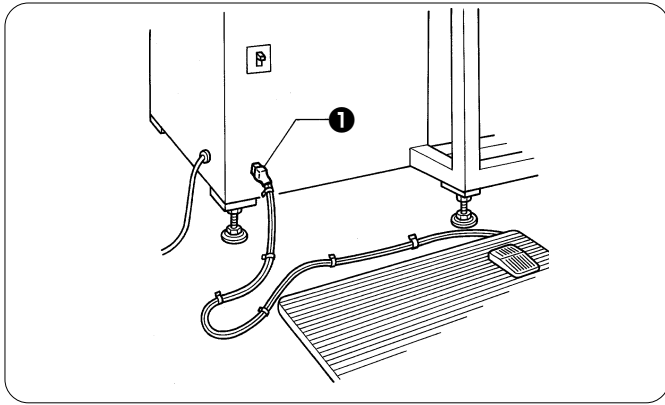

Connect connector **1** securely.

3-5. Connection of the air hose

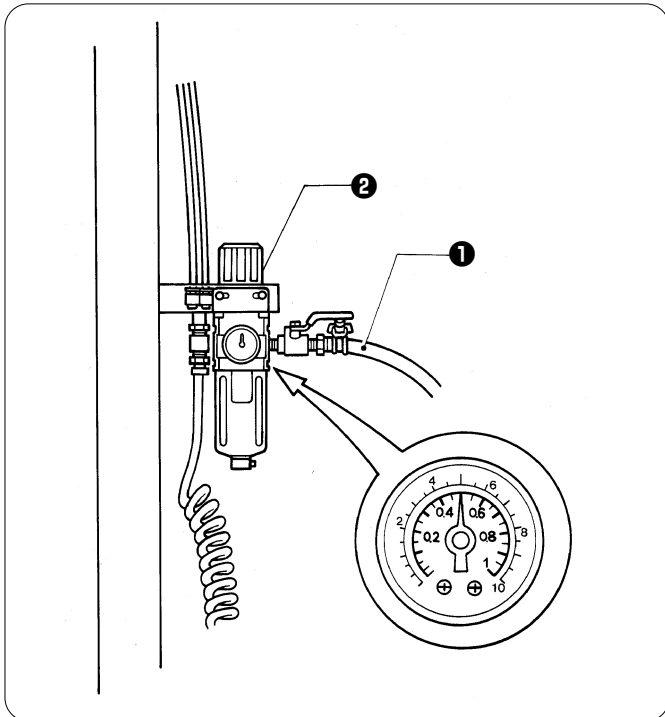

1. Attach air hose **1** to air unit valve **2**.
2. Move the upper cap of air unit valve **2** upward and adjust the air pressure to 0.49 MPa. (5 kgf/cm².)
3. After adjustment, move the cap downward and lock.

3-6. Positioning of the front supporter

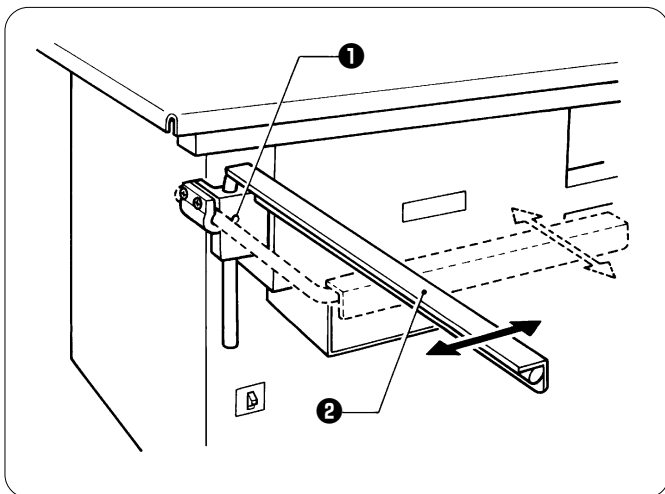

1. Loosen bolts **1** and position front supporter **2** in the most appropriate position.
2. Tighten bolts **1** to secure the supporter **2**.

3-7. Installation positions for operation box and switch box

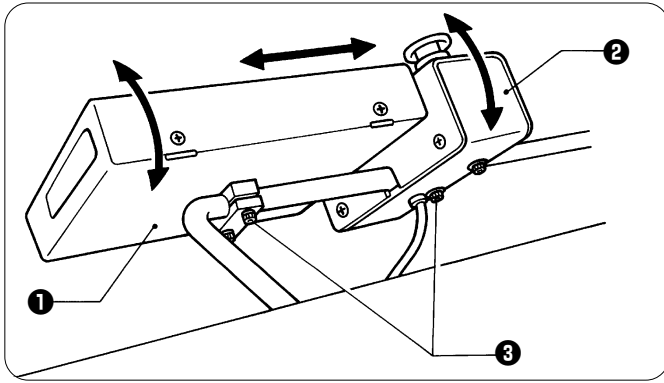

Loosen the mounting bolts **3** for the operation box **1** and switch box **2**, and move them in the direction of the arrow to a position where they are comfortable to operate.

3-8. Installation of the folding group assembly

Before installation

- Apply air pressure.
- Turn on power switch **1** to return the machine to the home position.
- Turn valve switch **2** to OFF (lower) side and "E-820" will flash on the display.

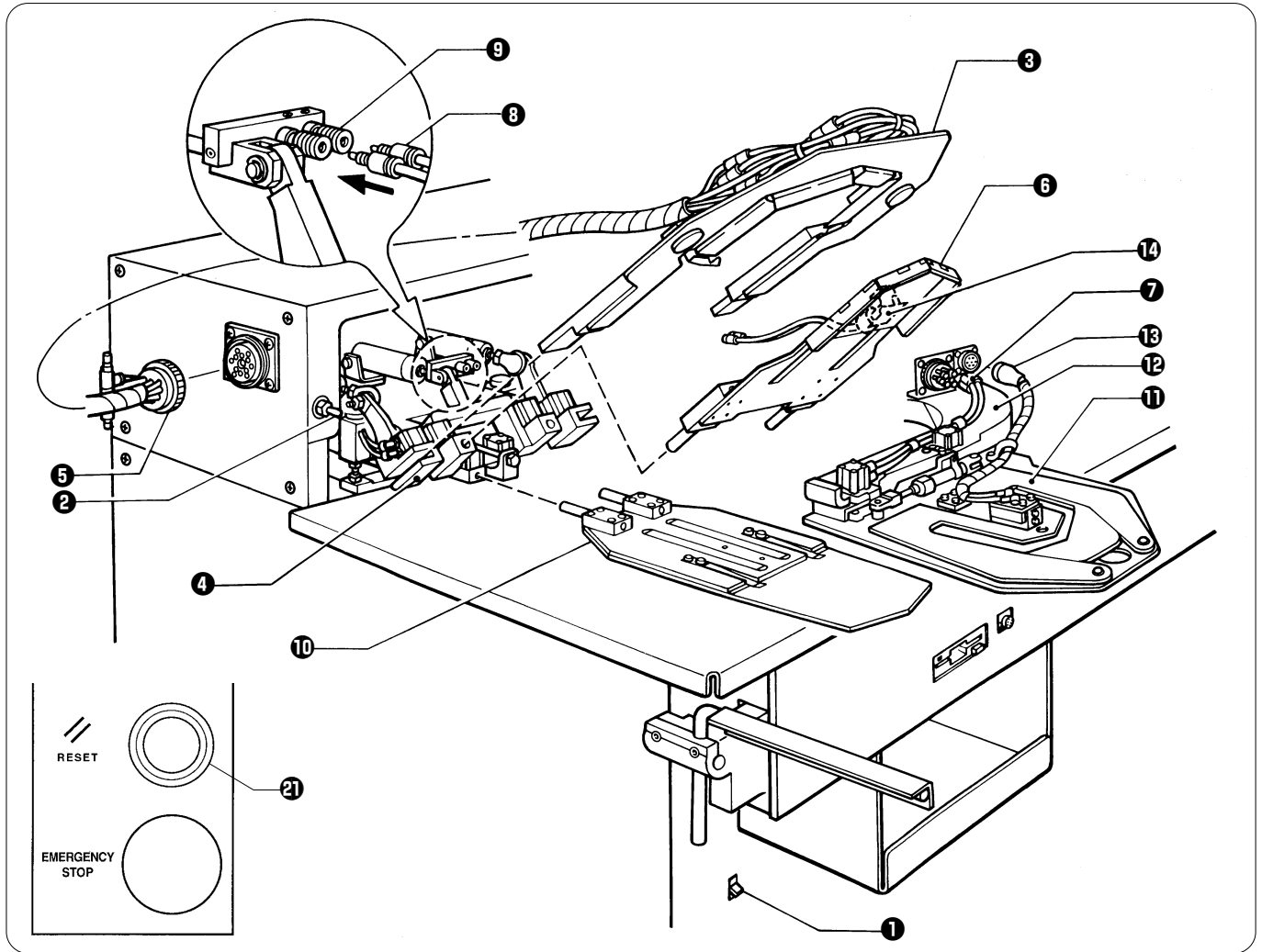

1. Install folding clamp assembly **3** onto folding base **4**.
2. Attach multi-connector **5**.
3. While pushing the folding clamp assembly **3** downwards with your hand, install the inner clamp assembly **6** to the folding base **4**. For models with a label attachment device **7**, install the plug **8** of the label attachment device **7** to the socket **9**.
At this time, set the label attachment device **7** so that it is in a ready condition on top of the inner clamp assembly. (Refer to page 27.) If it is reversed, it will turn downward.
4. Install center blade assembly **10** on folding base **4**.
5. Install sewing clamp assembly **11** on sewing clamp assembly arm base **12**.
6. Install the multi-connector **14** and the dual sensor harness assembly **13**.
7. Set the valve switch **2** to ON (up position).
The "E-820" indication will disappear from the display panel and the panel will return to its previous condition.
8. Move folding clamp assembly **3**, inner clamp assembly **6**, center blade assembly **10** and sewing clamp assembly **11** back and forth, and right and left, to ensure they are secured.

4. Lubrication

Note:

Check for sufficient oil through oil gauge windows A and B on the machine head and the table.
If the oil amount is not sufficient, be sure to replenish it.

How to oil the machine head

Replenish the oil through oil port ❶.

How to oil the machine table

- 1 Move the machine head forward so that the lubrication hole ❸ in the needle plate bracket RR ❷ and the lubrication port ❹ in the machine bed are aligned.
- 2 Apply oil to the lubrication port ❹ in the machine bed through the lubrication hole ❸ in the needle plate bracket RR ❷.

Note:

Before initial operation of the machine or after a long interval, be sure to drip a few drops of oil onto the arrowed lubrication point C.

How to drain oil from the machine body

Remove poly-oiler ❺ and drain the oil.

Rotary hook lubrication control

Turn the rotary hook lubrication adjustment valve ❻ to adjust the lubrication amount.

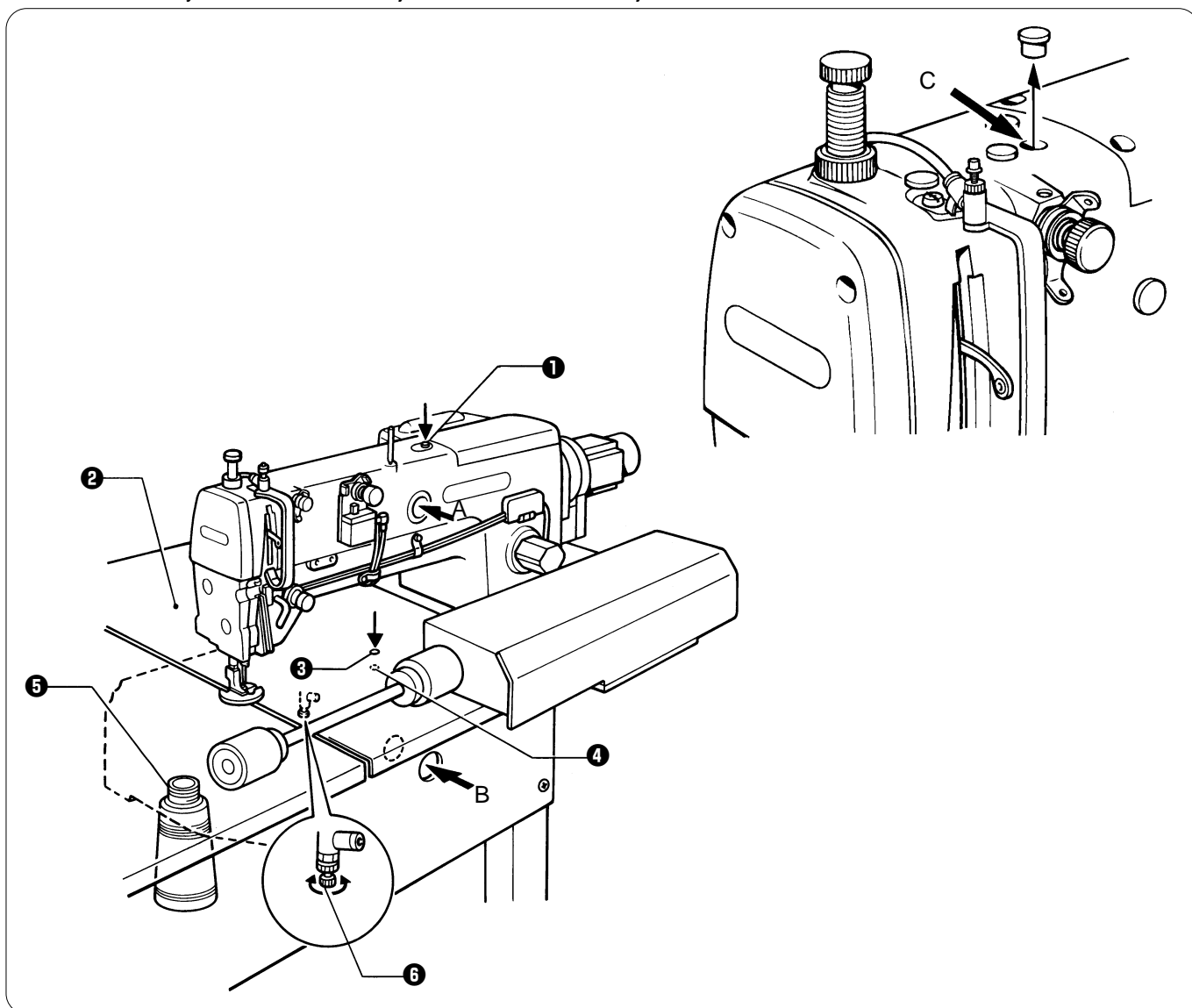

5. Correct operation

5-1. Installing the needle

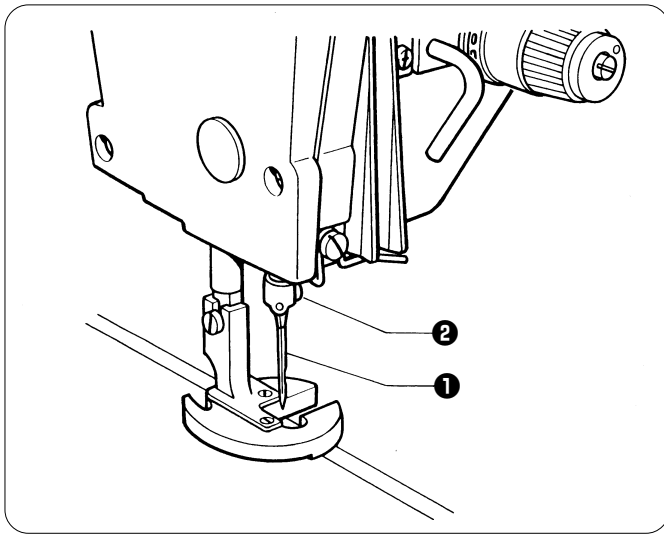

Fully insert needle **1**, with its long groove to the left, and secure it with screw **2**.

Note:

If the angle is incorrect, the needle and rotary hook will lock when the needle bar is at its lowest position, so make sure that the needle and rotary hook do not lock.

5-2. Upper threading

1. Apply air pressure and turn on power switch.
2. Press the FOLDER RESET button **19** to move the machine head back to the home position.
3. Press FOOT button **11** and lower presser foot **2**.
4. Pass the upper thread as illustrated below. After threading, be sure to press FOOT button **11** and lift presser foot **2**.
5. After threading, turn the pulley and lift the needle-bar to the uppermost position.

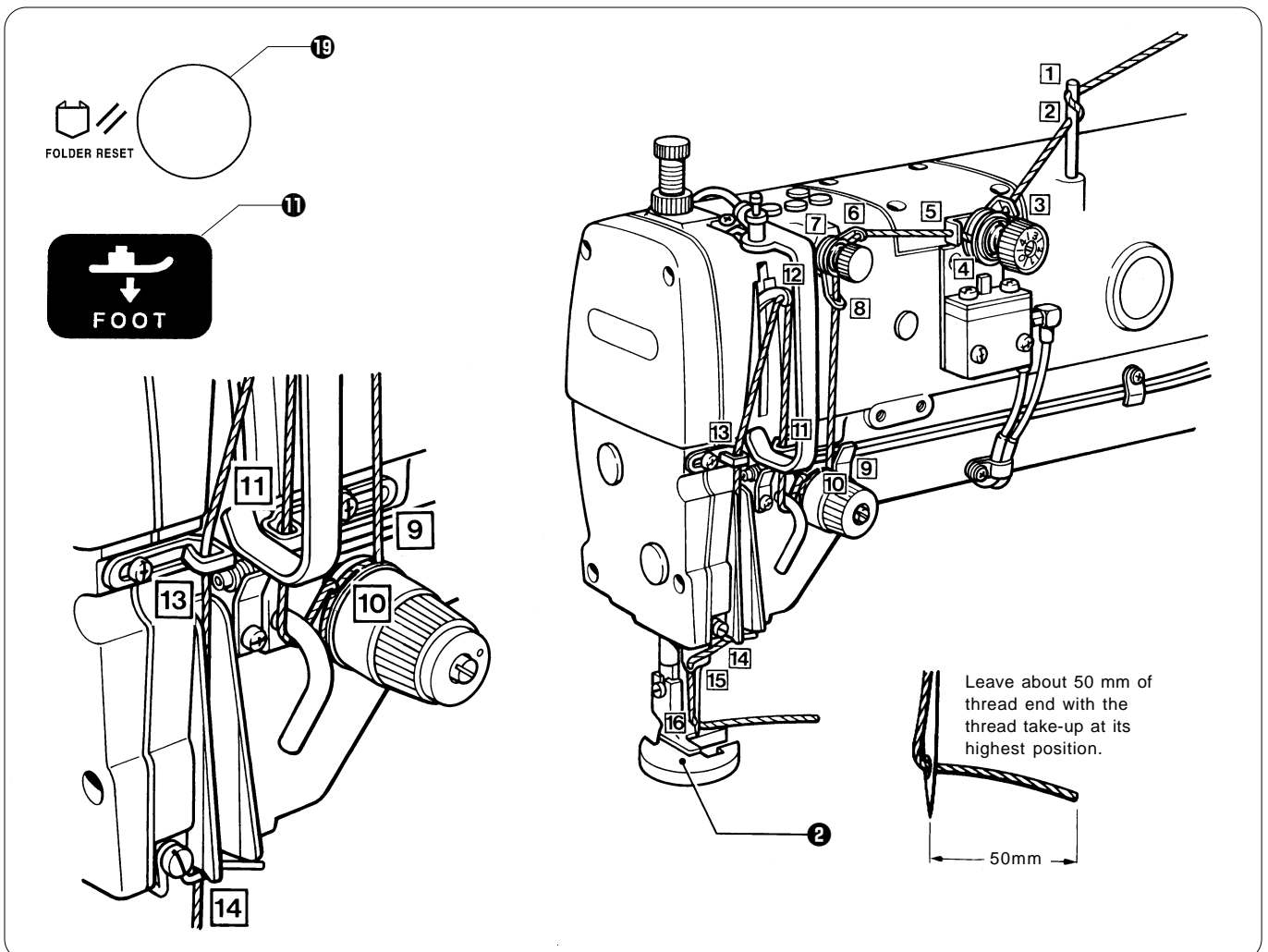

5-3. Bobbin case threading

■ Removal of the bobbin case

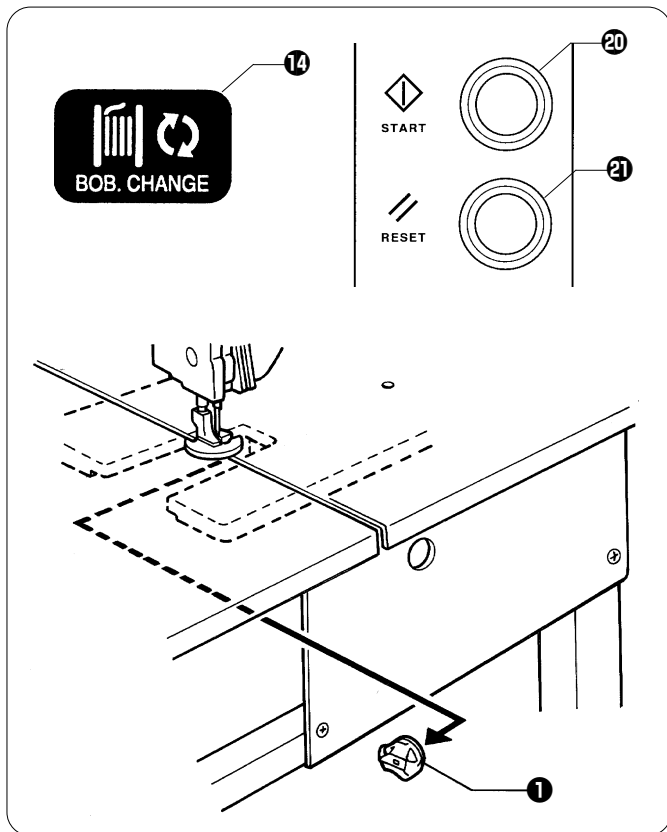

1. Press BOBBIN CHANGE button 14 and the machine will move toward you and stop;
2. Take out bobbin case 1. Replace the bobbin.
3. If the RESTART buttons 20 are pressed after the RESET button 21 has been pressed, the machine head will move back to the home position.

■ Removal of the bobbin

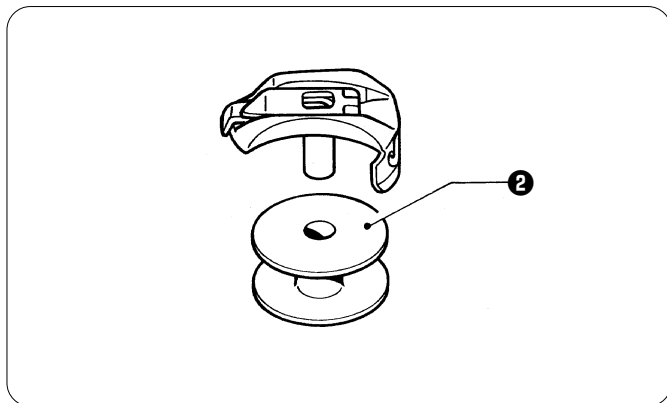

Bobbin 2 can be removed when the latch is released.

■ Bobbin case threading

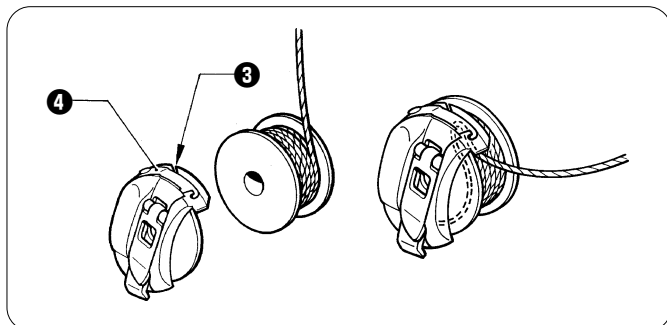

1. Insert the bobbin into the bobbin case.
2. Pass the thread through slot 3 and under adjustment spring 4.
3. Pull the thread out from adjustment spring 4.

5-4. Bobbin thread winding

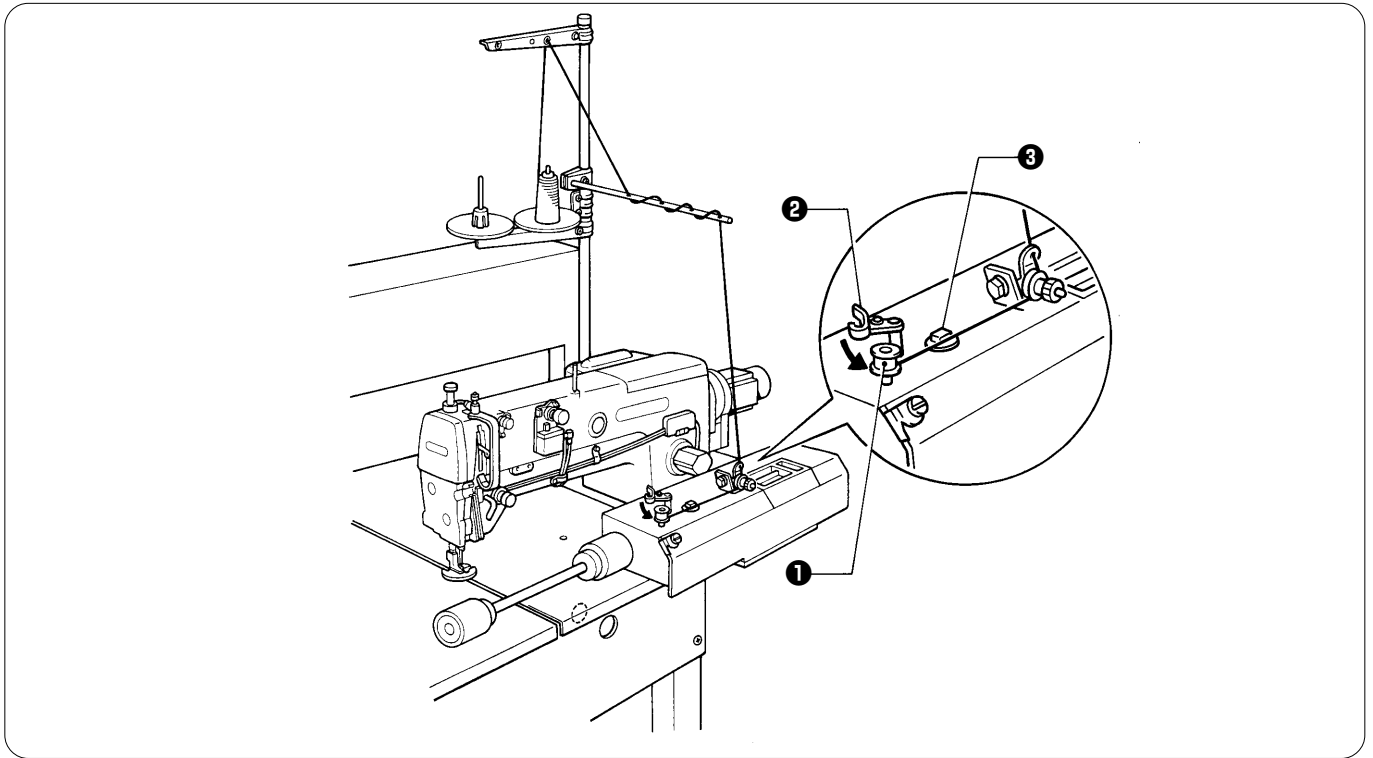

1. Pass the bobbin thread from the spool stand as illustrated below.
2. Wind the thread around the bobbin ❶ as arrowed.
3. Press lever ❷ against the bobbin ❶.
4. After completing bobbin ❶ thread winding, cut the thread.

Note:

Check for any idle rotation of the bobbin ❶. The motor may overheat, if the bobbin ❶ idles for a long time or if it rotates without a bobbin. At this time, protector ❸ will go up and the bobbin thread winding motor will not start. If protector ❸ is pressed after about 20 seconds has elapsed, bobbin thread winding can be restarted.

5-5. Thread tension

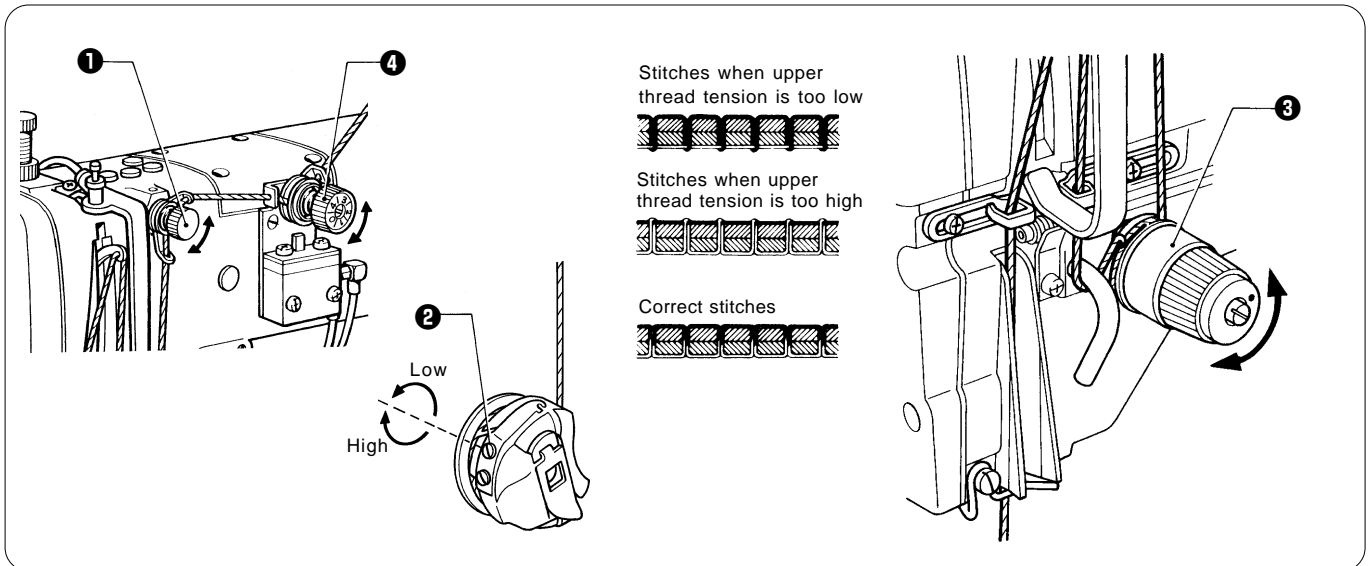

1. When the thread take-up lever is in the highest position after thread trimming, adjust the upper thread beyond the needle eye so as it is 35 to 40 mm long, by turning tension nut **1**. (50 - 70 g is standard).
2. Adjust the lower thread tension by turning tension regulating screw **2**. (30 - 40 g is standard.)
3. Adjust the upper thread tension by turning tension nut **3** and **4** after lowering the presser foot.

Note:

Then adjust the tension 30 - 40 g by turning tension nut **4**.
Main adjust is performed by using tension nut **3**. (150 - 200 g is standard).

■ Thread take-up spring

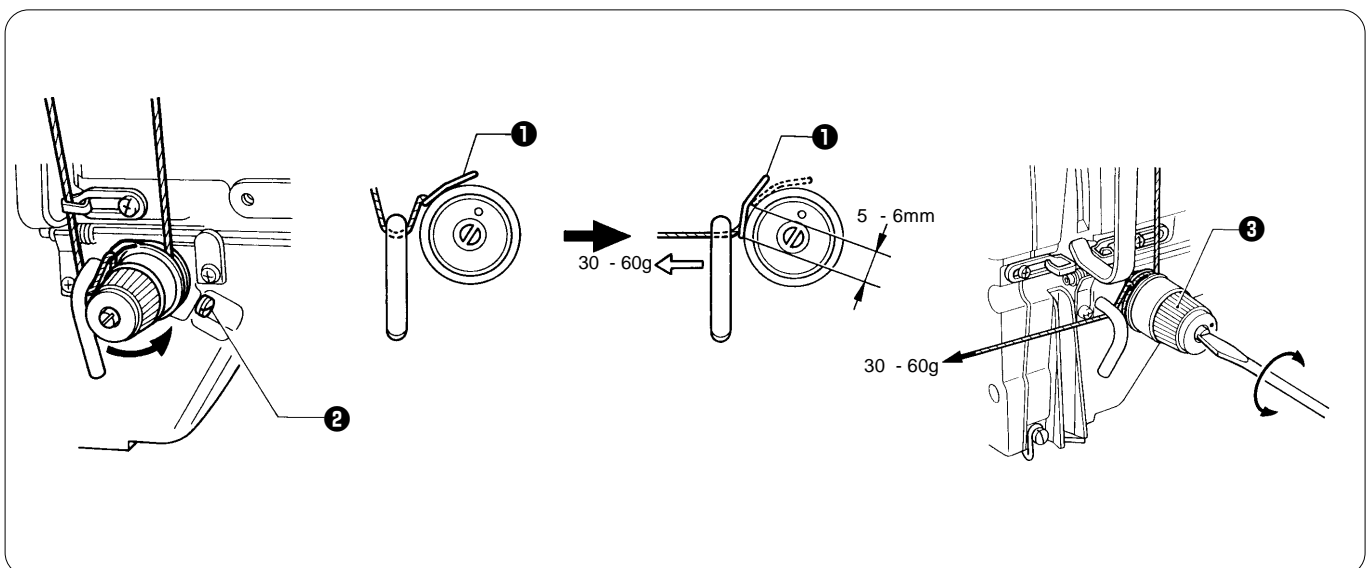

1. The standard height of the thread take-up spring **1** is when the stroke is 5 to 8 mm. In addition, the standard tension in the thread take-up spring is 50 g to 60 g. (The tension in the thread take-up spring is about 40 g when it is pulling the upper thread straight to the side at the point where the spring starts to move.)
2. To adjust the thread take-up spring height, loosen set-screw **2** and turn the whole unit of the tension regulator assembly.
3. To adjust the thread take-up spring force, insert a screwdriver tip into the groove of tension stud **3** and turn it as much as is appropriate.

6. Button functions

6-1. Operation box panel buttons

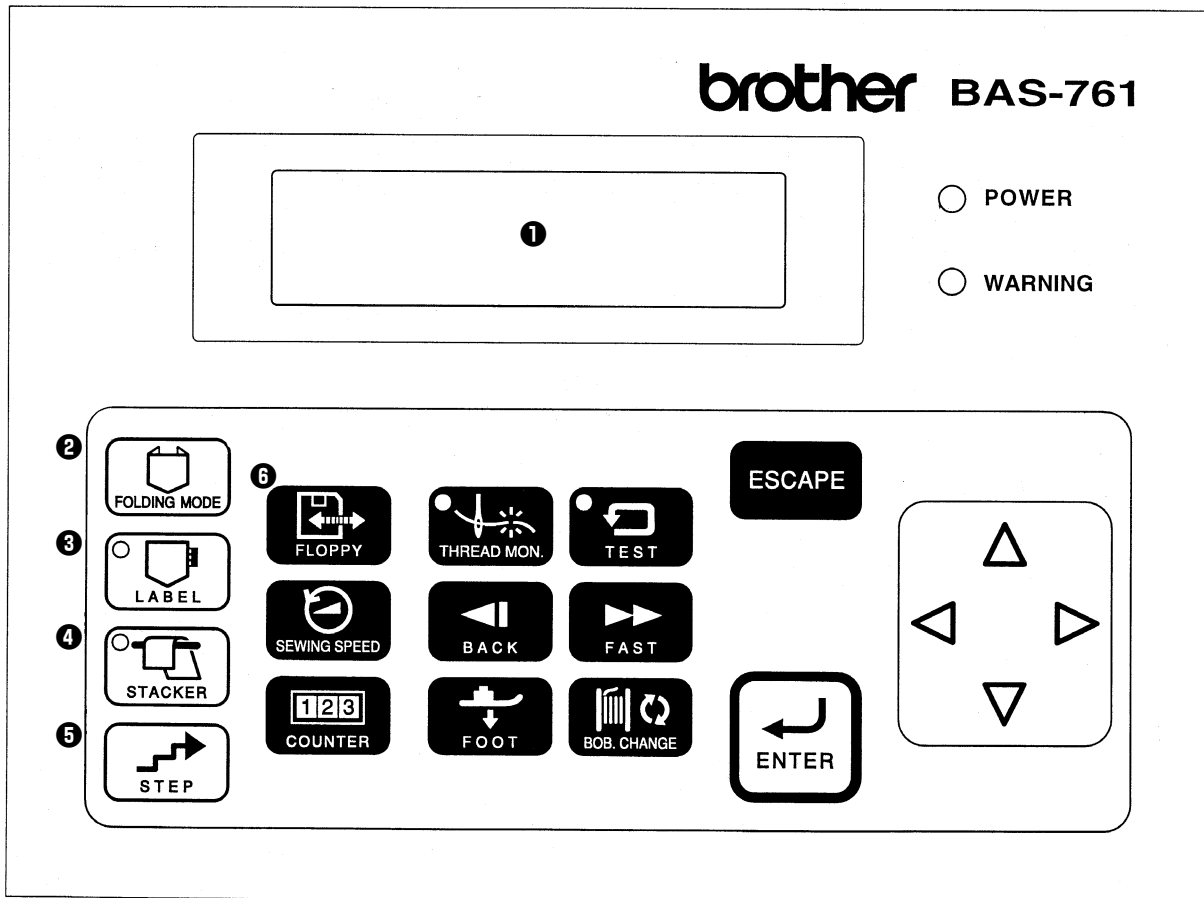

- 1** LCD screen
Displays sewing information and error messages.
- 2** FOLDING MODE button
This button is used to change the operating mode of the folder. Folder operating modes include automatic mode, pattern matching mode, label attachment mode and step mode.
- 3** LABEL button (LABEL indicator)
When the folder is in label attachment mode (for alternate label attachment) or in step mode, this button is used to set whether label attachment operations are carried out or not. The indicator at the side of the button illuminates and switches off each time the button is pressed.
When the indicator is illuminated, label attachment operations are carried out.
- 4** STACKER button (STACKER indicator)
This button is used to set whether stacking operations are carried out after sewing. The indicator at the side of the button illuminates and switches off each time the button is pressed.
When the indicator is illuminated, stacking operations are carried out.
- 5** STEP button
When the folder is in step mode, it can be moved forward one step at a time each time this button is pressed, in order to check the folding operation. If this button is pressed while the foot switch  is being depressed, the folder will move in reverse.
- 6** FLOPPY button
This button is used to store and retrieve sewing programs using a floppy disk.

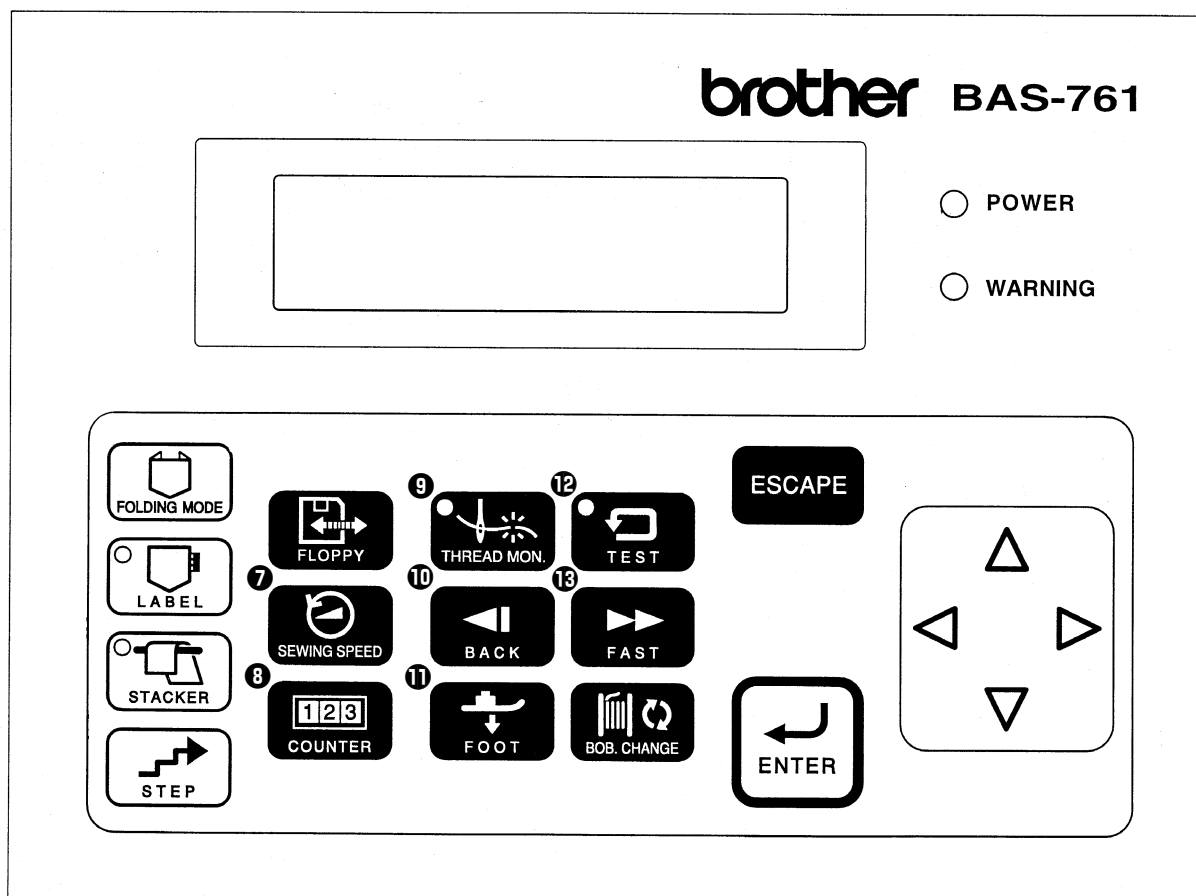

- 7 SEWING SPEED button**
This button is used to set the sewing speed and bar tacking speed. The sewing speed can be set in 9 steps from 500 to 4,250 rpm, and the bar tacking speed can be set in 7 steps from 500 to 3,500 rpm.
- 8 COUNTER button**
This button is used to set the lower thread counter, piece counter decrement (cleared when 0), stacker roller feed amount, date and time. The setting item changes each time this button is pressed.
- 9 THREAD MONITOR button (THREAD MONITOR indicator)**
This button is used to set whether or not sewing stops automatically when an upper thread breakage occurs. The indicator at the side of the button illuminates and switches off each time the button is pressed. When the indicator is illuminated, upper thread breakages are detected.
- 10 STEP BACK button**
This button is used to resume sewing after an upper thread breakage occurs. The feed mechanism moves in reverse while this button is being pressed.
- 11 FOOT button**
This button is used to raise and lower the presser foot. The presser foot moves up and down each time this button is pressed.
- 12 TEST button (TEST indicator)**
This button is used to carry out test feeding in order to check the number of stitches. Feeding is carried out without the machine head operating. The indicator at the side of the button illuminates and switches off each time the button is pressed. When the indicator is illuminated, test operation is being carried out. When the indicator is switched off, normal sewing is carried out.
- 13 FAST button**
This button is used to increase the speed of step back or test operation. The feed mechanism moves faster while this button is being pressed. In addition, this button can also be used to set the piece counter to 0 (cleared).

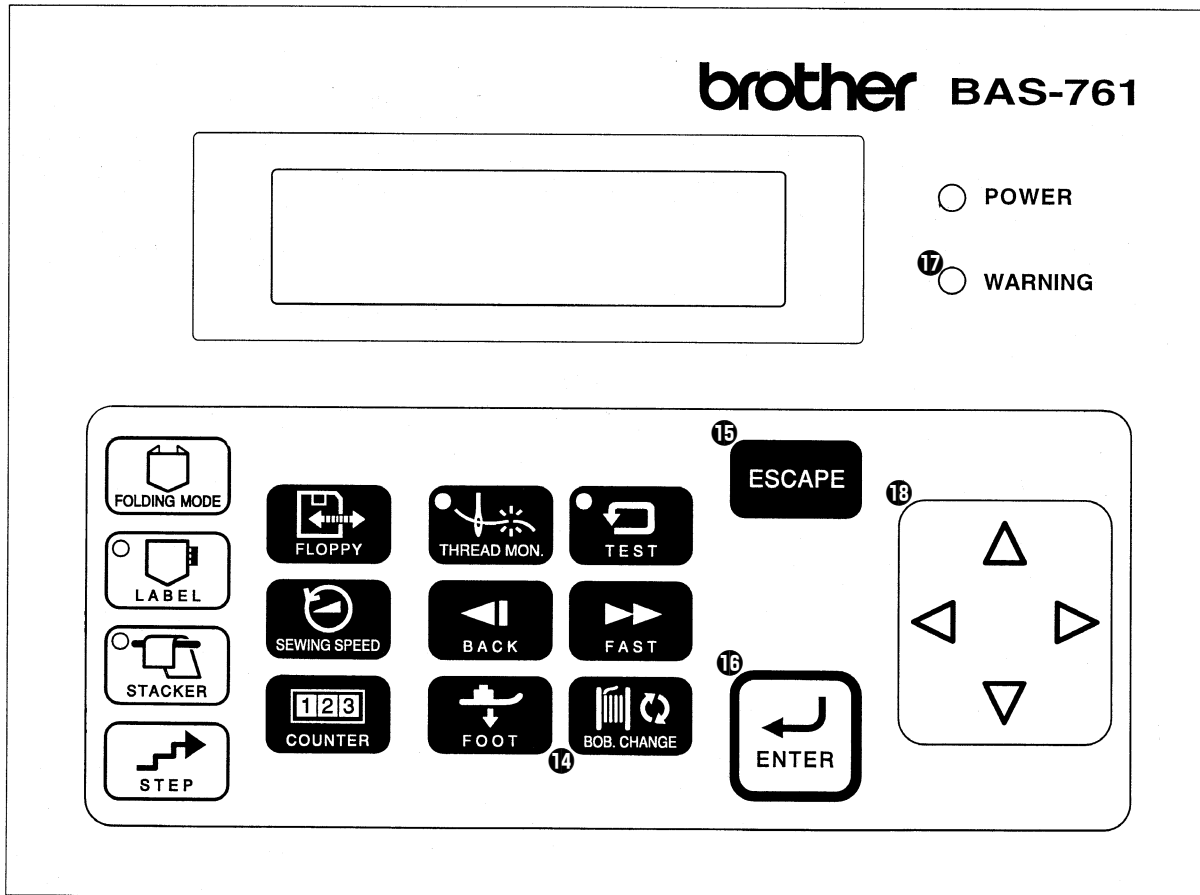

- 14** **BOBBIN CHANGE** button
 If this button is pressed when changing the bobbin, the machine head can be moved forward to make bobbin changing easier.
- 15** **CANCEL** button
 If this button is pressed during folder mode setting, while data is being saved to or read from a floppy disk, while the sewing speed is being set or if the COUNTER button is being used to change a setting, the setting changes or operations will be canceled and the setting mode will be exited.
- 16** **ENTER** button
 If this button is pressed during folder mode setting, while data is being saved to or read from a floppy disk, while the sewing speed is being set or if the COUNTER button is being used to change a setting, the setting changes will then become effective.
- 17** **Warning indicator**
 This indicator illuminates when an abnormality occurs or when the EMERGENCY STOP button has been pressed.
- 18** **Arrow keys**
 If this button is pressed during screen selection, folder mode setting, while data is being saved to or read from a floppy disk, while the sewing speed is being set or if the COUNTER button is being used to change a setting, the setting value or mode can be changed.

6-2. Switch box panel buttons

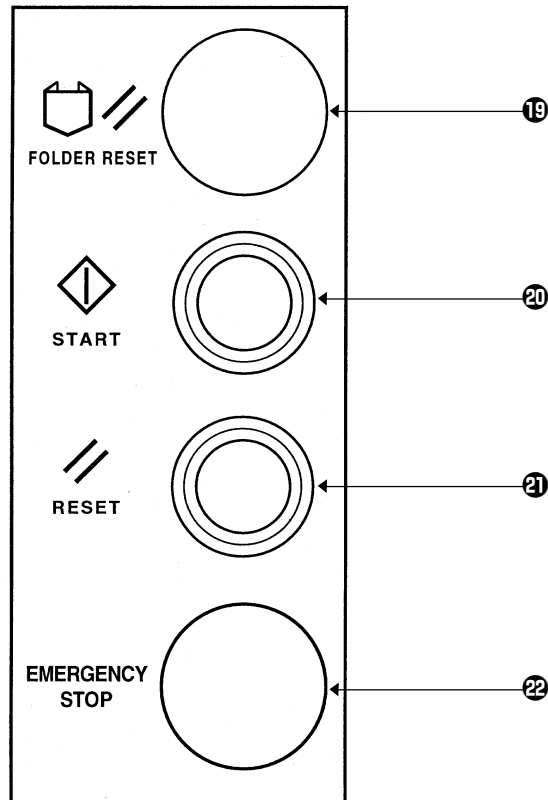

- 19** FOLDER RESET button (carries out positioning when the power is turned on)
 This button is used to stop the folder while folding is in progress and to reset the folding condition. When the button is pressed once, folding is stopped, and when it is pressed twice, the folder is reset, and the workpiece and the pocket can then be set.
- 20** START button
 This button is used to resume sewing after an emergency stop has occurred during sewing or after an upper thread breakage has occurred. It should be pressed after the RESET button has been pressed. In addition, if an error has occurred, this button is used to continue operation after the cause of the error has been eliminated.
- 21** RESET button
 This button is used to trim the thread after an emergency stop has occurred during sewing or after an upper thread breakage has occurred. In addition, if an error has occurred, this button is used to clear the error status after the cause of the error has been eliminated.
- 22** EMERGENCY STOP button
 This button is used to stop all operations.

6-3. Foot switch

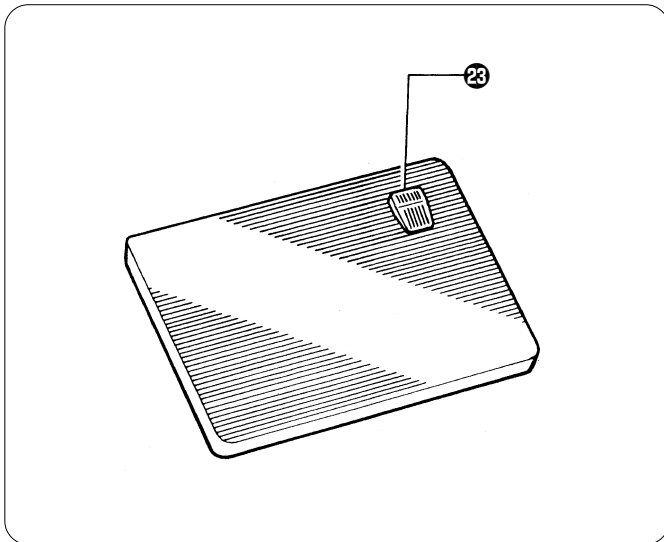

Foot switch 23

When the folder is in automatic mode, this switch is used to operate the vacuum system.

When the folder is in pattern matching mode, this switch is used to raise and lower the folder table to carry out pattern matching.

When the folder is in label attachment mode, this switch is used to carry out label attaching.

When the folder is in step mode, this switch operates in the same way as in label attachment mode or automatic mode, depending on whether label attachment operations are being carried out or not.

6-4. RESTART buttones

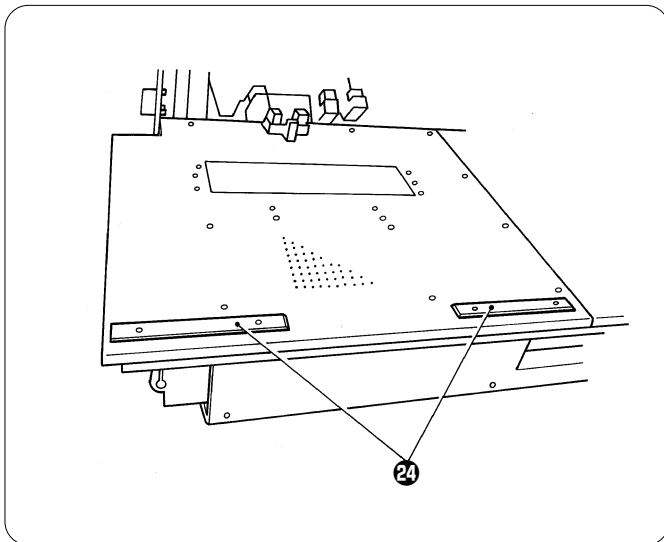

RESTART buttones 24

When these buttones are pressed simultaneously, the folder starts operating.

7. Settings before sewing

Press FOLDER RESET SW
to start searching for home
position.

7-1. Setting the folder mode

FOLDING MODE **AUTO**
PATTERN
LABEL
STEP

Screen 1

Note

Background color of the selected mode
turns reverse on display.

1. Turn on the air pressure and then turn on the power switch.
The screen shown at left will be displayed on the panel.
2. Press the FOLDER RESET button **19**. The machine head will move to the home position and then stop in the standby condition.

1. Press the FOLDING MODE button **2**. Screen 1 will then be displayed.



2. Press the arrow keys **18** to select the mode.



If the CANCEL button **15** or FOLDING MODE button **2** is pressed once more, the mode will not be changed and the screen will return to the original display.



3. Press the ENTER button **19**. The new mode will be set and the screen will return to the original display.



7-2. Setting the sewing speed and the bar tacking speed

- These settings can be made when the machine head is at the standby position, while the bobbin is being replaced and while sewing is stopped.
- The bar tacking speed cannot be greater than the sewing speed. If the bar tacking speed is set to a faster speed than the sewing speed, the bar tacking speed will become the same as the sewing speed when sewing is actually carried out.

Change sewing speed.
SEWING SPEED 4000 rpm

Screen 2-1

1. Press the SEWING SPEED button **7**. Screen 2-1 will then be displayed.



2. Press the arrow keys **18** to select the desired sewing speed.



The sewing speed can be set in 9 steps from 500 to 4,250 rpm.

* If the CANCEL button **15** is pressed, the sewing speed will not be changed and the screen will return to the original display.



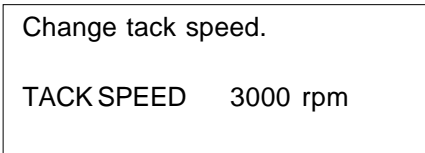

Screen 2-2

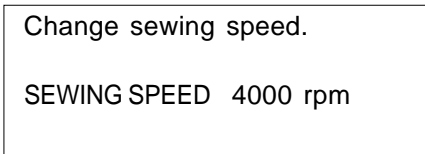

Screen 2-1

* If the SEWING SPEED button **7** is pressed once more, the sewing speed will not be changed, and screen 2-2 for changing the bar tacking speed will be displayed.



3. Press the ENTER button **19**. The sewing speed will be changed to the new setting, and screen 2-2 for changing the bar tacking speed will be displayed.



4. Press the arrow keys **18** to select the desired bar tacking speed.



The bar tacking speed can be set in 7 steps from 500 to 3,500 rpm.

* If the CANCEL button **15** or SEWING SPEED button **7** is pressed, the bar tacking speed will not be changed and the screen will return to the original display.



5. Press the ENTER button **19**. The bar tacking speed will be changed to the new setting, and the screen will return to the initial display.



• The maximum number of stitches is limited by the sewing pitch in the sewing data as shown in the table below.

Pitch	Max. sewing speed
– 3.5mm	4250rpm
3.55 – 4.5mm	3500rpm
4.55 – 5.0mm	3000rpm
5.05 – 6.0mm	2500rpm

7-3. Setting the lower thread counter

- The lower thread counter determines how many workpieces can be produced according to the amount of lower thread which has been wound inside the bobbin case.
- This setting can be made when the machine head is at the standby position and while the bobbin is being replaced.

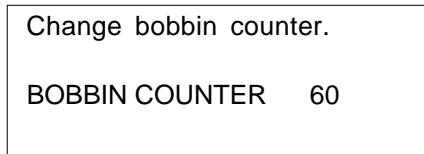

Screen 3

1. Press the COUNTER button **8** once. Screen 3 will then be displayed.



2. Use the arrow keys **13** to change the counter setting. Use the [<] and [>] keys to select the column, and use the [Δ] and [∇] keys to change the digit.

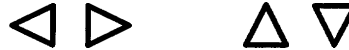

If the CANCEL button **15** is pressed, the lower thread counter will not be changed and the screen will return to the original display.



3. Press the ENTER button **16**. The lower thread counter will be changed to the new setting, and the screen will return to the initial display.



■ Replacing the lower thread

When the value for the lower thread counter becomes "0", the machine head automatically moves forward. After the bobbin is replaced and the reset operation is carried out, the value for the counter returns to the setting value.

NOTE:

If the BOBBIN CHANGE button is pressed manually, and the above operation is carried out, the lower thread counter will not return to the setting value. In addition, if the value is set to "0", the lower thread counter will not operate.

7-4. Setting the piece counter

- This setting can be made when the machine head is at the standby position and while the bobbin is being replaced.
- The piece counter can be set to "0" (reset), or it can be decremented by 1. It cannot be incremented.

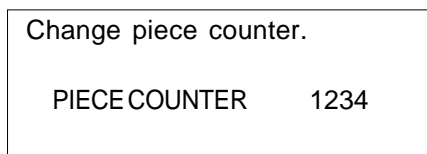

Screen 4

1. Press the COUNTER button **8** twice. Screen 4 will then be displayed.



2. Press the FAST button **13** to reset the piece counter to "0".



Press the arrow key **13** once to decrement the piece counter by 1.



* If the CANCEL button **15** is pressed, the piece counter value will not be changed and the screen will return to the original display.



3. Press the ENTER button **16**. The piece counter will be changed to the new setting, and the screen will return to the initial display.



7-5. Setting the stacker roller feed amount

- This setting can be made when the machine head is at the standby position and while the bobbin is being replaced.

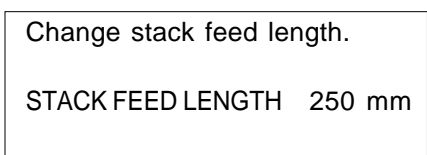

Screen 5

1. Press the COUNTER button **8** three times. Screen 5 will then be displayed.



2. Press the arrow keys **13** to select the desired stacker roller feed amount.



The setting can be made in 9 steps from 0 mm to 400 mm, with each step being 50 mm.

3. Press the ENTER button **16**. The stacker roller feed amount will be changed to the new setting, and the screen will return to the initial display.



7-6. Setting the date and time

This setting can be made when the machine head is at the standby position and while the bobbin is being replaced.

Change date.	
DATE	1998/10/1

Screen 6-1

Change time.	
TIME	15:30:00

Screen 6-2

1. Press the COUNTER button **8** four times. Screen 6-1 will then be displayed.



2. Press the [◀] and [▶] arrow keys **18** to select the year, month or day, and press the [▽] and [△] arrow keys **19** to change the setting for the selected item.

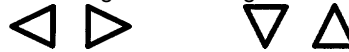

- * If the CANCEL button **15** is pressed, the date will not be changed and the screen will return to the original display.



- * If the COUNTER button **8** is pressed, the date will not be changed and the screen will change to screen 6-2 for setting the time.



3. Press the ENTER button **16**. The date will be changed to the new setting, and the screen will change to screen 6-2 for setting the time.



4. Press the [◀] and [▶] arrow keys **18** to select the hour or minutes, and press the [▽] and [△] arrow keys **19** to change the setting for the selected item.



- * If the CANCEL button **15** or COUNTER button **8** is pressed, the time will not be changed and the screen will return to the original display.



5. Press the ENTER button **16**. The time will be changed to the new setting, and the screen will return to the initial display. The seconds will be reset to "0" at the point where the ENTER button **16** is pressed.





8. Preparation for sewing

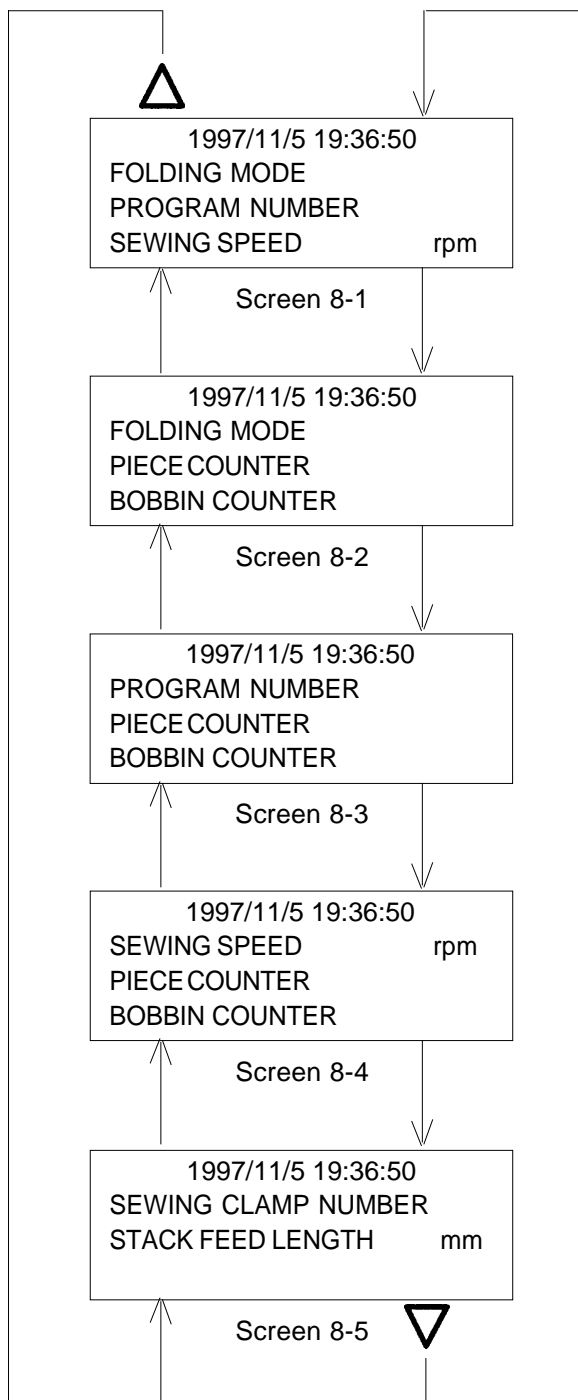

Press FOLDER RESET SW
to start searching for home position.

Screen 7

1. Apply air pressure and turn on power switch. Screen 7 will then be displayed on the panel.
2. Press the FOLDER RESET button . The machine head will move to the home position and then stop in the standby condition.



3. Select the normal display screen. The screen displayed will change in the following order each time the arrow key  is pressed. Screen 8-1 → screen 8-2 → ... It will change in the following order each time the arrow key  is pressed.

Screen 8-5 → screen 8-4 → ...
 

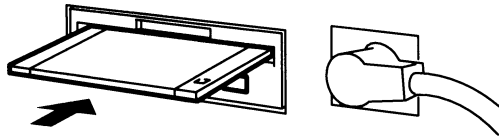

4. Insert a floppy disk.

Note:

Insert a floppy disk straight into the slot.
The label side of the disk must face the front.

5. Press the FLOPPY button **6**. Screen 9 will then be displayed.



Use the arrow keys **13** to select the same number as the work clamp assembly. Then use the [<] and [>] arrow keys **13** to select the column, and use the [Δ] and [∇] arrow keys **13** to change the values.

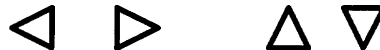

Refer to page 35 for details on setting the work clamp assembly number.

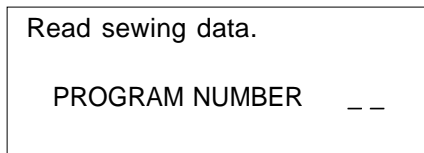

Screen 9

6. Press the ENTER button **15**. The sewing data which corresponds to the number specified will then be read from the floppy disk.

* The sewing data will be backed up even when the power is turned off. The number for the backed-up sewing data can be checked by viewing the program number on screen 8-1 or screen 8-3.

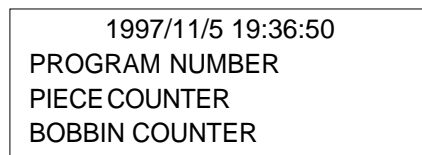

Screen 8-3

NOTE:

If there is no backup data, the display will be blank.

7. Check that the THREAD MONITOR indicator **9** is illuminated. If it is switched off, press the THREAD MONITOR button **9** until the indicator is illuminated.



NOTE:

If the indicator is switched off, the machine head will not stop automatically if an upper thread breakage is detected during sewing.

8. If starting to sew with a new bobbin, set the lower thread counter by following the steps given on page 20.

9. Follow the steps given on page 21 to reset the piece counter to "0" if required.

10. Follow the steps given on page 18 to set the sewing speed if required.

11. If the STACKER indicator **4** is switched off, press the STACKER button **4** so that the indicator illuminates.



NOTE:

If the indicator is switched off, the workpieces will not be stacked after they have been sewn.

9. Sewing

9-1. Sewing with the folder in automatic mode

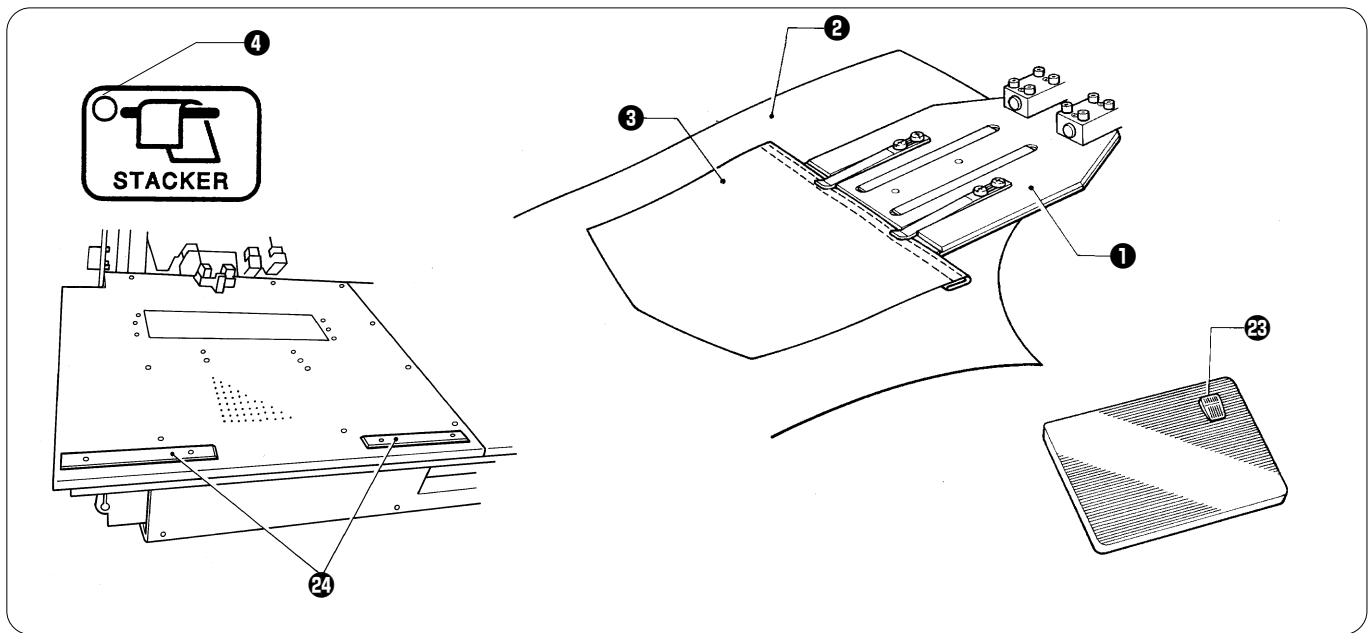

1. Turn on the air pressure and then turn on the power switch. The following screen will be displayed on the panel.

Press FOLDER RESET SW
to start searching for home position.

2. Press the FOLDER RESET button 19. The machine head will move to the home position and then stop in the standby condition.



3. Set the folder mode to automatic mode.

NOTE:

Refer to page 18 for details on how to set the folder mode.

4. Press the STACKER button 4 so that the STACKER indicator is illuminated.
5. Place the workpiece 2 under the gauge assembly 1. (*1)
6. Depress the foot switch 23. The vacuum system will start operating to hold the workpiece 2 in place.

NOTE:

If the foot switch 23 is depressed once more, the vacuum system will turn off while the foot switch 23 is being depressed, allowing the workpiece to be positioned more easily.

7. Place the pocket material 3 on top of the gauge assembly 1.
8. Press the RESTART buttones 24 simultaneously. The pocket material 3 will be folded by the folder and the workpiece 2 and the pocket material 3 will then be moved to the machine head and sewing will start. (*2)
9. Once sewing is finished, the stacker will operate and the workpiece 2 will be stacked. The machine head and the work clamp will then return to the standby positions.

- *1 If DIP switch D-1 has been set to ON, the gauge assembly 1 will retract. The gauge assembly 1 moves forward at the same time the vacuum system starts operating when the foot switch 23 is depressed.
- *2 If DIP switch A-1 has been set to ON, operation stops momentarily after folding has been completed so that the folding can be checked. When the RESTART buttones 24 are pressed again simultaneously, operation continues as before.

9-2. Sewing with the folder in pattern matching mode

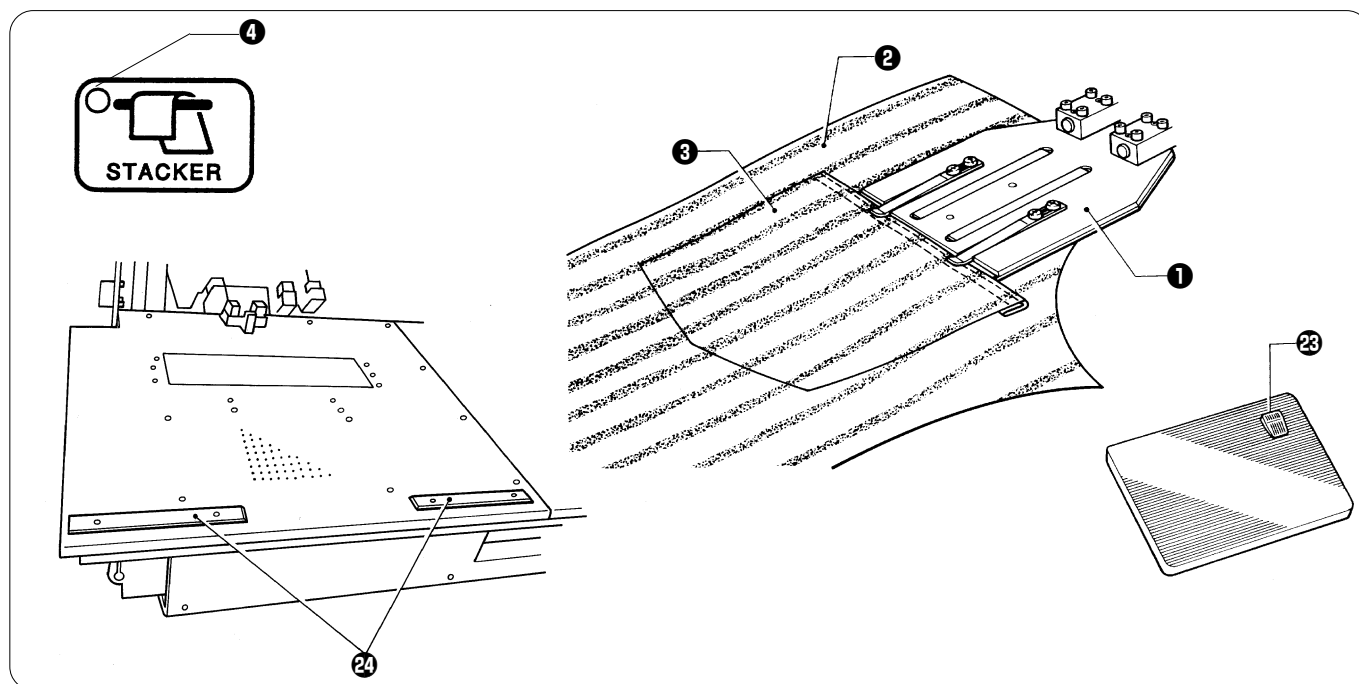

1. Turn on the air pressure and then turn on the power switch. The following screen will be displayed on the panel.

Press FOLDER RESET SW
 to start searching for home
 position.

2. Press the FOLDER RESET button (19). The machine head will move to the home position and then stop in the standby condition.

3. Set the folder mode to pattern matching mode.

NOTE:

Refer to page 18 for details on how to set the folder mode.

4. Press the STACKER button (4) so that the STACKER indicator is illuminated.
5. Place the workpiece (2) under the gauge assembly (1). (*1)
6. Depress the foot switch (23). The vacuum system will start operating to hold the workpiece (2) in place.
7. Place the pocket material (3) on top of the gauge assembly (1).
8. When the foot switch (23) is released from being depressed, the gauge assembly (1) will drop to its lowest position. If the pattern on the pocket material (3) is not aligned with the pattern on the workpiece (2) at this time, depress the foot switch (23) once more. The vacuum system will turn off and the gauge assembly (1) will move one step upward so that the patterns can be matched.
9. Press the RESTART buttons (24) simultaneously. The pocket material (3) will be folded by the folder and the workpiece (2) and the pocket material (3) will then be moved to the machine head and sewing will start. (*2)
10. Once sewing is finished, the stacker will operate and the workpiece (2) will be stacked. The machine head and the work clamp will then return to the standby positions.

- *1 If DIP switch D-1 has been set to ON, the gauge assembly (1) will retract. The gauge assembly (1) moves forward at the same time the vacuum system starts operating when the foot switch (23) is depressed.
- *2 If DIP switch A-1 has been set to ON, operation stops momentarily after folding has been completed so that the folding can be checked. When the RESTART buttons (24) are pressed again simultaneously, operation continues as before.

9-3. Sewing with the folder in label attachment mode

- Two types of label attachment mode can be used: when DIP switch D-2 is set to OFF, alternate label attachment is carried out, and when DIP switch D-2 is set to ON, continuous label attachment is carried out.
- With alternate label attachment, the folder switches alternately between label attachment mode and automatic mode once for each sewing operation. During label attachment mode, the LABEL indicator ❸ illuminates. If you would like to switch over the modes, press the LABEL button ❸.
- With continuous label attachment, label attachment mode is active all the time. (The LABEL indicator ❸ will remain illuminated.)

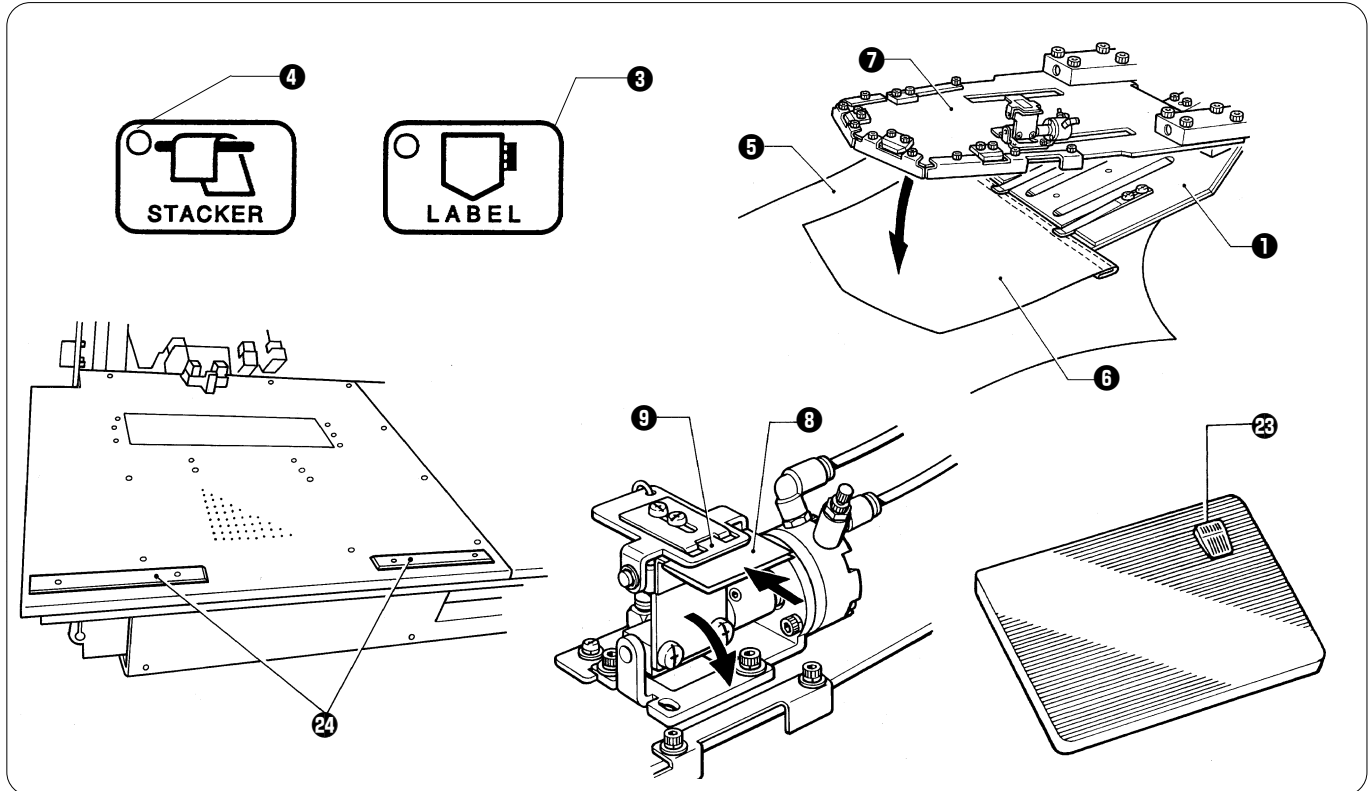

1. Set the folder mode to label attachment mode.

NOTE:

Refer to page 18 for details on how to set the folder mode.

2. Press the STACKER button ❹ so that the STACKER indicator is illuminated.
3. Place the workpiece ❺ under the gauge assembly ❶. (*1)
4. Depress the foot switch ❽. The vacuum system will start operating to hold the workpiece ❺ in place.
5. Place the pocket material ❻ on top of the gauge assembly ❶.
6. Depress the foot switch ❽, and hold it in that condition. The intermediate work clamp ❷ will be set down on top of the gauge assembly ❶ and label setting will be possible. Place the label ❸ into the clamp ❹ of the label attacher. After setting the label ❸ in place, release the foot switch ❽. The clamp ❹ of the label attacher will clamp the label ❸ and then rotate to the folding position. If you would like to reclamp the label ❸, depress the foot switch ❽ once more and keep it depressed. The label can then be reset.
7. Press the RESTART buttones ❿ simultaneously. The pocket material ❻ will be folded by the folder and the workpiece ❺ and the pocket material ❻ will then be moved to the machine head and sewing will start. (*2)
8. Once sewing is finished, the stacker will operate and the workpiece ❺ will be stacked. The machine head and the work clamp will then return to the standby positions.

* If the LABEL indicator e is switched off, it means that automatic mode is active.

*1 If DIP switch D-1 has been set to ON, the gauge assembly ❶ will retract. The gauge assembly ❶ moves forward at the same time the vacuum system starts operating when the foot switch ❽ is depressed.

*2 If DIP switch A-1 has been set to ON, operation stops momentarily after folding has been completed so that the folding can be checked. When the RESTART buttones ❿ are pressed again simultaneously, operation continues as before.

9-4. Sewing with the folder in step mode

- In step mode, the folder operates in a step-by-step manner, so that checking can be carried out during folding.
- If the LABEL indicator ③ is switched off, automatic mode is followed during step mode operation. If the LABEL indicator ③ is illuminated, label attachment mode is followed.

NOTE:

Selecting the mode to be followed is carried out by using the LABEL button ③.



Press FOLDER RESET SW
to start searching for home
position.

1. Turn on the air pressure and then turn on the power switch.
The screen shown at left will be displayed on the panel.
2. Press the FOLDER RESET button ⑩. The machine head will move to the home position and then stop in the standby condition.



3. Set the folder to step mode.

NOTE:

Refer to page 18 for details on how to set the folder mode.

4. Press the STACKER button ④ so that the STACKER indicator is illuminated.



5. Place the workpiece ① under the gauge assembly ①.
(*1)
6. Depress the foot switch ⑳. The vacuum system will start operating to hold the workpiece ① in place.
7. Place the pocket material ③ on top of the gauge assembly ②.

8. The folder operates one step at a time each time the STEP button ⑤ is pressed.



9. If you continue to press the STEP button ⑤ after folding has been completed, the work clamp assembly will move to the folder side and operation will continue from transporting to sewing.

NOTE:

At any point up until the folder is released, the folder can be moved in reverse by depressing and holding the foot switch ⑳ while pressing the STEP button ⑤.

*1 If DIP switch D-1 has been set to ON, the gauge assembly ② will retract. The gauge assembly ② moves forward at the same time the vacuum system starts operating when the foot switch ⑳ is depressed.

9-5. Test feeding



Test feeding should always be carried out a new program is created or when changes are made to existing data.

NOTE:



Check that the needle does not touch the work clamp.

1. Carry out the sewing preparation as far as step 6.
2. Press the TEST button  and check that the TEST indicator is illuminated.







3. Operate the folder in the same way as for normal sewing. The folder can be set to any mode.
4. After folding is complete, the work clamp assembly will transport the workpiece to the machine head, and feeding will then continue stitch by stitch according to the program contents without the machine head motor operating. If the FAST button  is pressed during feeding, the feeding speed will become faster for as long as the FEED button  is being pressed.





5. If the TEST button  is pressed during the above feeding operation, feeding will stop and the TEST indicator  will switch off.



At this time:

- If the TEST button  is pressed once more, the TEST indicator  will illuminate and feeding will start again.
- If the STEP BACK button  is pressed, the feeding will be carried out in reverse for as long as the STEP BACK button  is being pressed. If it is pressed together with the FAST button , the feeding speed will become faster.



- If the RESTART button  is pressed without pressing the TEST button , sewing will start from the current stopping position.



6. Once feeding is complete, the machine head and the work clamp will then return to the standby positions.

9-6. Emergency stop

To stop the machine during sewing

If you would like to stop the machine head during sewing, press the EMERGENCY STOP button ⑳. The machine head will stop and the error message "E-801" will appear on the panel screen.

If the RESET button ㉑ is then pressed, the thread will be trimmed and the screen will return to the normal display.



To continue sewing

1. Press the STEP BACK button ㉒ to return to the place from where you would like sewing to resume.



2. Press the RESTART button ㉓ to start sewing again.



To interrupt sewing and return to the standby position

1. Press the EMERGENCY STOP button ㉔ during sewing to stop the sewing machine. Then press the RESET switch ㉑ so that a normal screen is displayed, and press the EMERGENCY STOP button ㉔ once more. The error message "E-801" will appear on the panel display. Press the EMERGENCY STOP button ㉔ once more. The error message "E-801" will appear on the panel display.

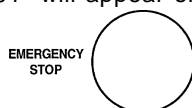

2. Press the RESET button ㉑. Screen 7 (Refer to page 23) will be displayed.



3. Press the FOLDER RESET button ㉕. The machine head will return to the home position and stop in standby mode.



If a thread breakage occurs during sewing

If the thread breaks during sewing, the machine head will stop and error message "E-520" will appear on the panel display. When the RESET button ㉑ is pressed, thread trimming will be carried out, and the screen will return to the normal display.







1. Thread the upper thread and move the thread take-up lever to its highest position.
2. Press the STEP BACK button ㉒ to return to the place from where you would like sewing to resume.



3. Press the RESTART button ㉓ to start sewing again.



10. Standard adjustments

⚠ CAUTION	
<p> Maintenance and inspection of the sewing machine should only be carried out by a qualified technician.</p> <p> Ask your Brother dealer or a qualified electrician to carry out any maintenance and inspection of the electrical system.</p> <p> Turn off the power switch and disconnect the power cord from the wall outlet at the following times, otherwise the machine may operate if the foot switch is depressed by mistake, which could result in injury.</p> <ul style="list-style-type: none"> • When carrying out inspection, adjustment and maintenance • When replacing consumable parts such as the rotary hook and knife 	<p> Hold the machine head with both hands when tilting it back or returning it to its original position. Furthermore, after tilting back the machine head, do not push the face plate side or the pulley side from above, as this could cause the machine head to topple over, which may result in personal injury or damage to the machine.</p> <p> If the power switch needs to be left on when carrying out some adjustment, be extremely careful to observe all safety precautions.</p> <p> If any safety devices have been removed, be absolutely sure to re-install them to their original positions and check that they operate correctly before using the machine.</p>

Note:

- Turn the power switch off if the adjustment does not need power to be supplied.
- If the power switch is turned on, take sufficient safety measures, such as to make E-800 (emergency stop) come on in the manual mode.

10-1. Needle-bar height adjustment

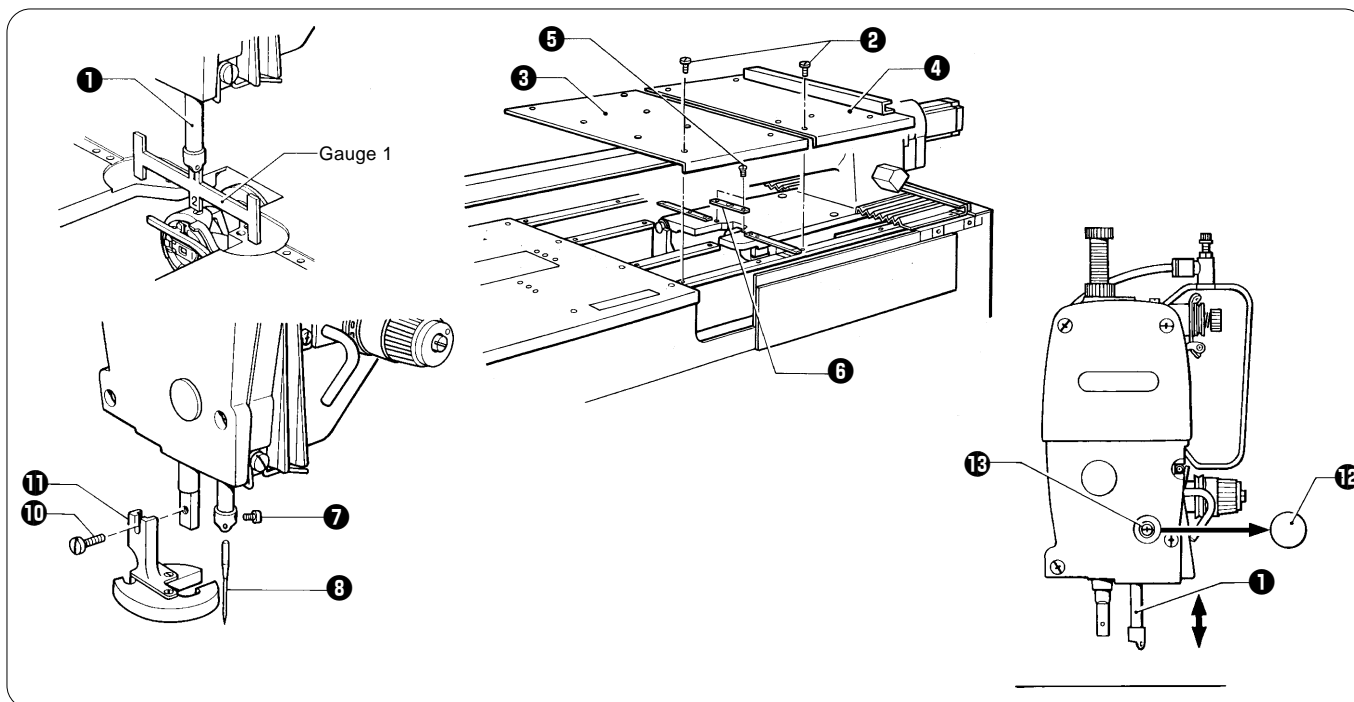

When needle-bar ① is at its lowest position, the lower end of needle-bar ① must be matched the end of gauge 1.

1. Remove flat-head screws ② and then needle plate RR ③ and needle plate RL ④.
2. Loosen the screw ⑦ and then remove the needle ⑧.
3. Remove screws ⑤ and then bottom-plunger ⑥.
4. Remove screw ⑩ and then presser foot assembly ⑪.
5. Remove oil cap ⑫ and screw ⑬, adjust the height by moving needle-bar ① up and down.

10-2. Needle and rotary hook timing

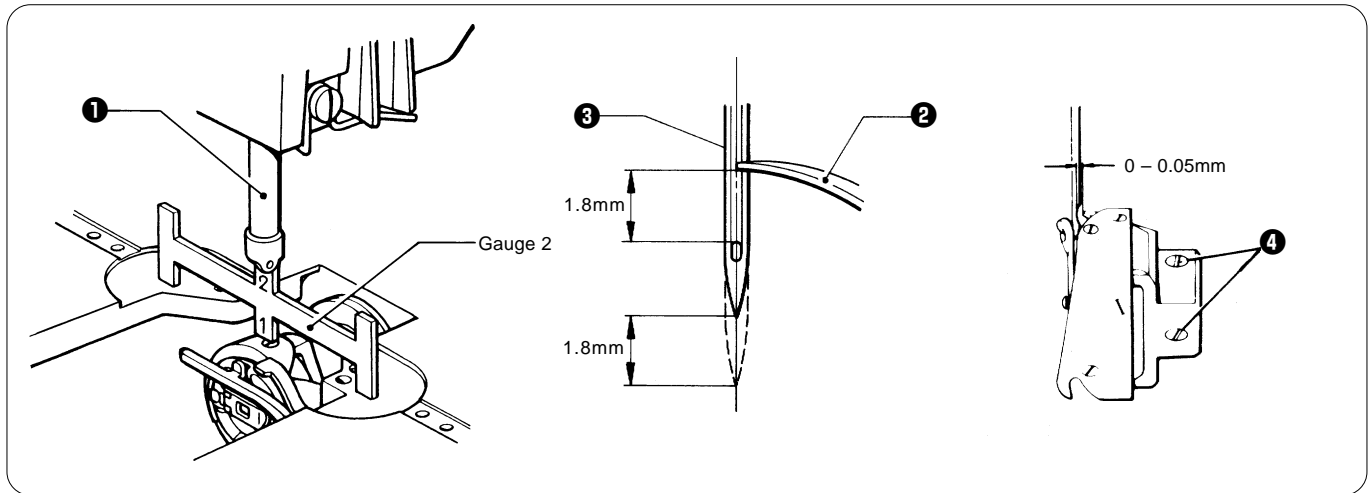

- After needle-bar **1** is raised from its lowest position, rotary hook point **2** must be aligned with the center of needle **3** when the lower end of needle-bar **1** is matched the end of gauge **2**.
- If rotary hook point **2** is not aligned with the center of needle **3**, loosen screws **4** and align the center of needle **3** with rotary hook point **2**.

10-3. Presser foot height adjustment

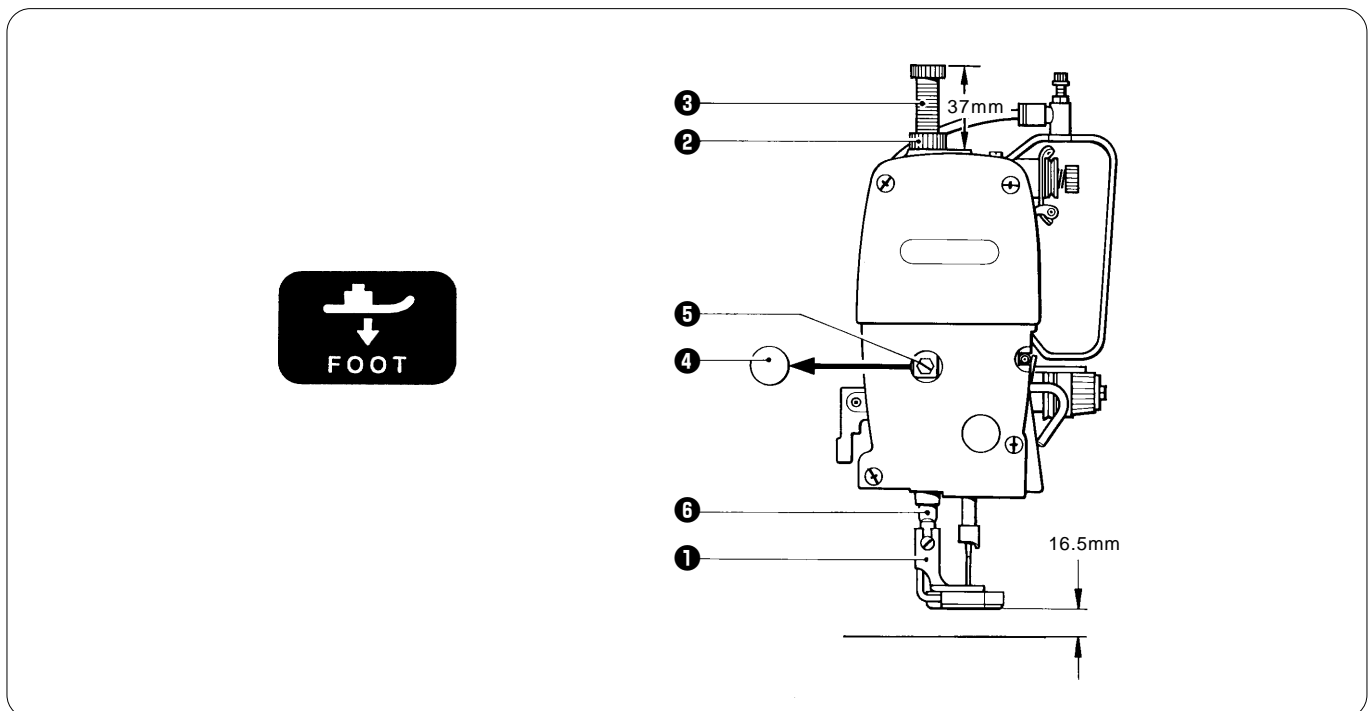

The standard presser foot height is 14.5 mm above the needle plate when presser foot **1** is raised.

1. Loosen nut **2** and then pressure adjusting screw **3**.
2. Press the FOOT button to raise working presser foot **1**.
3. Remove face-plate oil cap **4** and loosen screw **5**. Adjust the height by moving presser bar **6**.

The standard spring tension for the sewing clamp spring is obtained when the height of the presser foot adjustment screw is 37 mm.

10-4. Removal of the fixed knife and the movable knife

Note:

Turn off the power switch.

■ Removal of the fixed knife

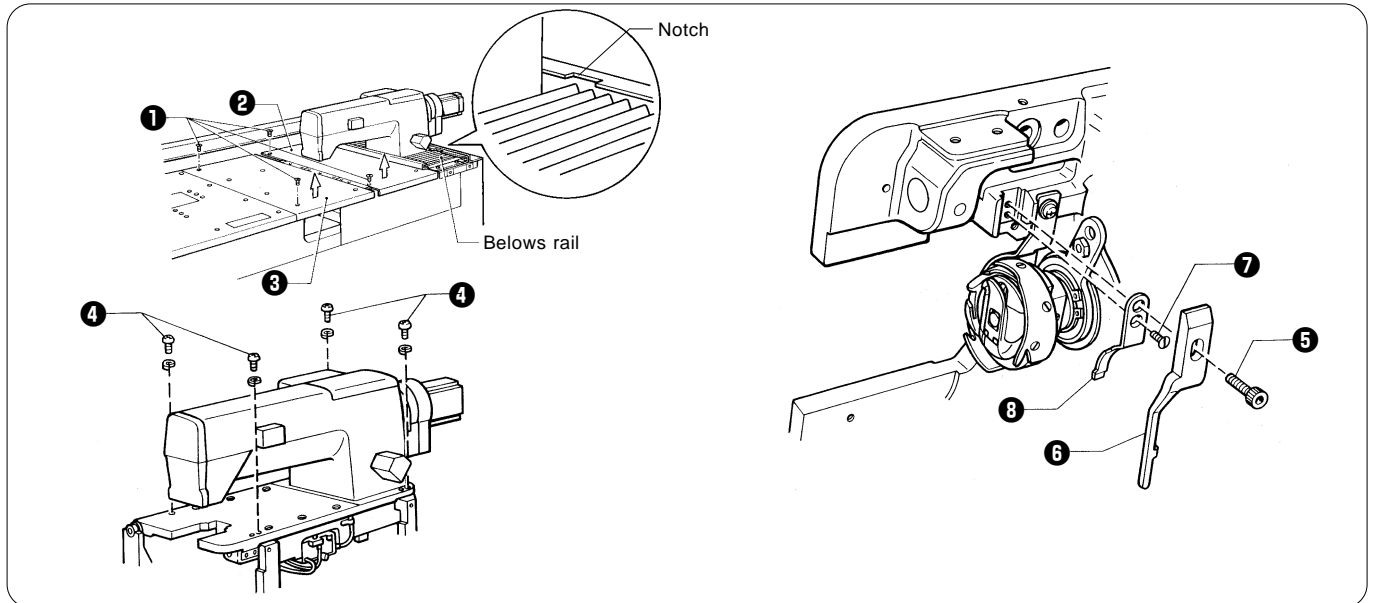

1. Remove flat-head screws ① and then needle plate RR ② and needle plate RL ③.

2. Remove clamping screws ④ and then tilt the machine head.

NOTE:

At this time, adjust the position of the machine head so that it is aligned with the notch in the bellows rail.

3. Remove clamping bolt ⑤ and then bobbin case holder position bracket ⑥.

4. Remove flat-head screw ⑦ and then fixed knife ⑧.

- When the fixed knife ⑧ becomes blunt, sharpen it as illustrated at right.

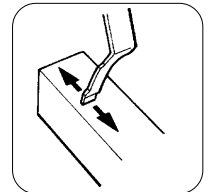

■ Removal of the movable knife

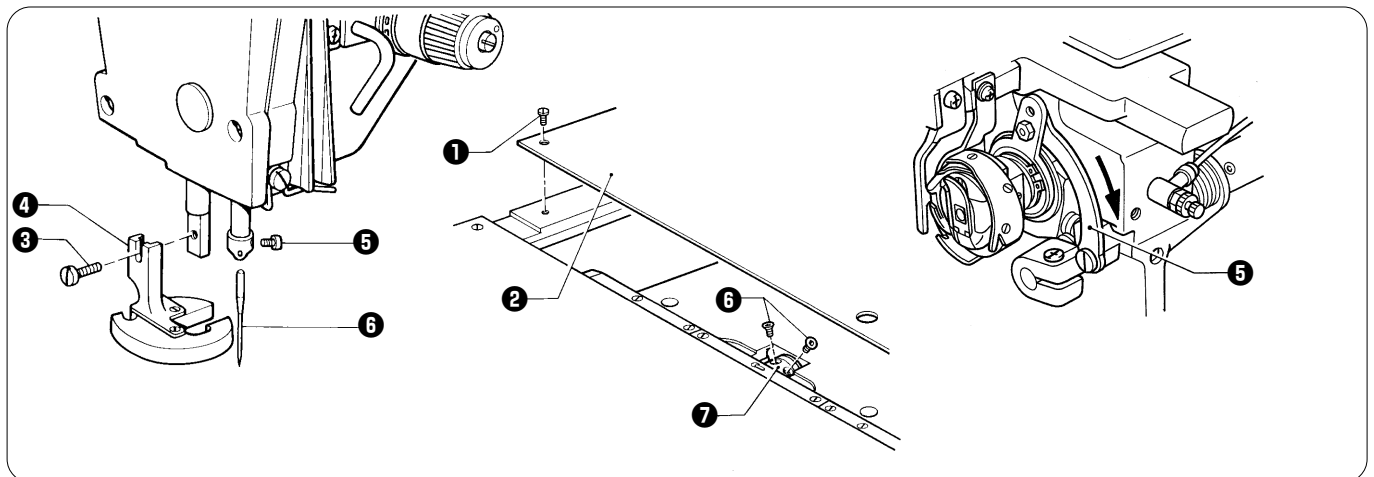

1. Remove flat-head screws ① and then needle plate RR ②.

2. Remove clamping screw ③ and then presser foot assembly ④.

3. Turn the pulley and stop the needle bar at its highest position.

4. Remove screw ⑤ and then needle ⑥.

5. Push thread trimming rod ⑤ in the arrowed direction and stop where flat-head screws ⑥ can be seen.

6. Remove flat-head screws ⑥ and then movable knife ⑦.

Note:

To reassemble, reverse the above procedures.

10-5. Stacker position adjustment

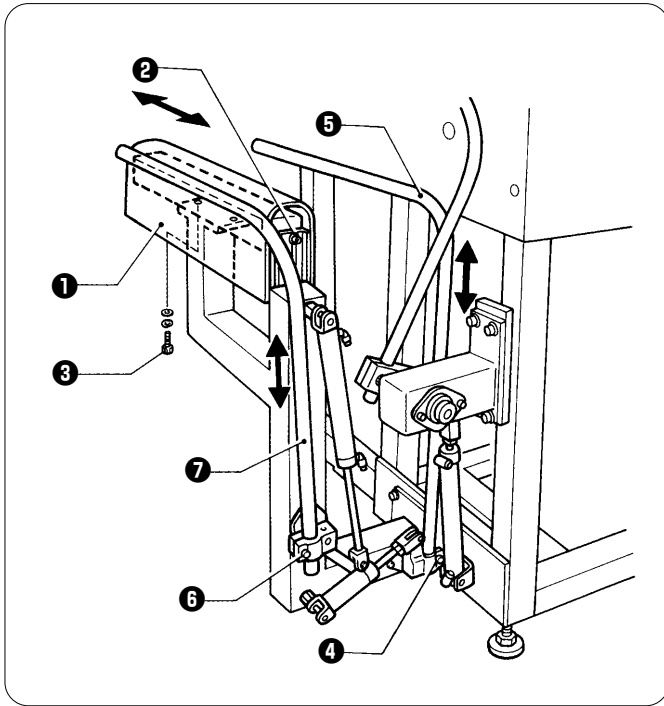

1. Loosen the four bolts **2** and adjust the height of the stacker base **1** so that the workpieces stack neatly onto the stacker base **1**.
2. Loosen the two bolts **3**, and then adjust the vertical position of the stacker base **1** so that the workpieces stack neatly onto the stacker base **1**. Then tighten the bolts **3**.
3. Loosen the bolt **4** and adjust the height of the inner work clamp bar **5**.
4. Loosen the bolt **6** and adjust the height of the outer work clamp bar **7**.

10-6. Sewing clamp assembly number selection

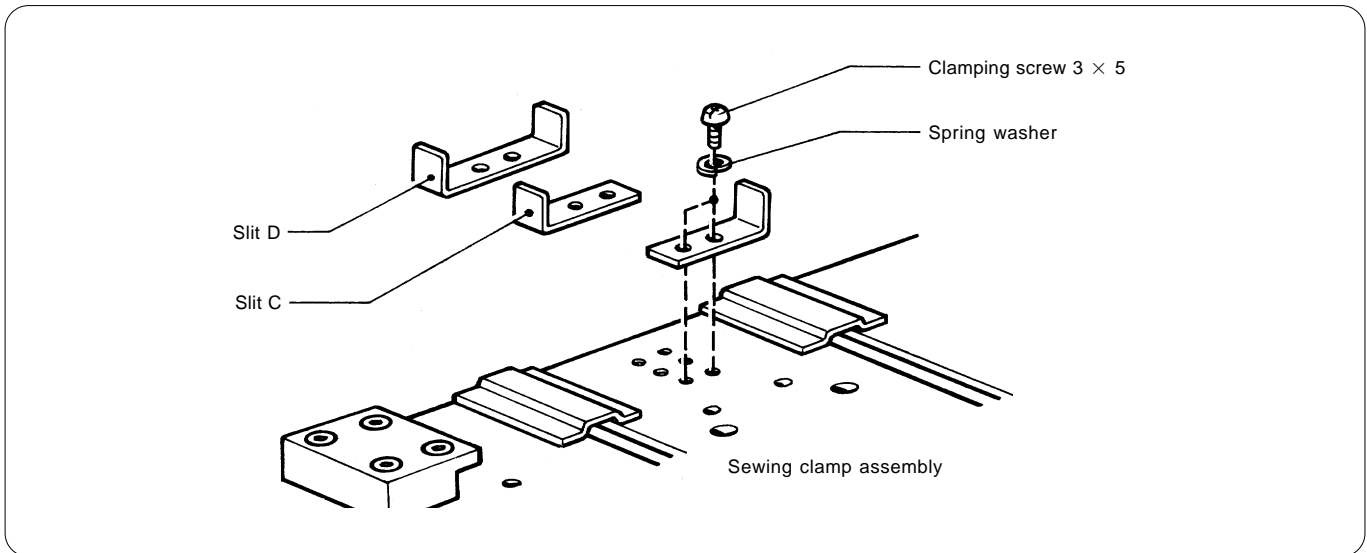

- Attach slit C and Slit D to the sewing clamp assembly by a clamping screw and a spring washer. See the table below for the sewing clamp assembly numbers.

■ Sewing clamp assembly number

NOTE:

- For retractable clamps, set jumpers 0 to 31.
- For single clamps, set jumpers 32 to 63.

0	1	2	3	4	5	6	7	8	9	10	11
○ ○ ○ ○ ○ ○	○ ○ ○ ○ ● ●	○ ○ ● ● ○ ○	○ ○ ● ● ● ●	● ● ○ ○ ○ ○	● ● ○ ○ ● ●	● ● ● ● ○ ○	● ● ● ● ● ●	○ ○ ○ ○ ● ●	○ ○ ○ ○ ● ●	○ ○ ● ● ● ●	○ ○ ● ● ● ●
12	13	14	15	16	17	18	19	20	21	22	23
● ● ○ ○ ● ●	● ● ○ ○ ● ●	● ● ● ● ● ●	● ● ● ● ● ●	○ ○ ● ● ○ ○	○ ○ ● ● ● ●	○ ○ ● ● ○ ○	○ ○ ● ● ● ●	● ● ● ● ● ○	● ● ● ● ● ●	● ● ● ● ○ ○	● ● ● ● ● ●
24	25	26	27	28	29	30	31				
○ ○ ● ● ● ●	○ ○ ● ● ● ●	○ ○ ● ● ● ●	○ ○ ● ● ● ●	● ● ● ● ● ●	● ● ● ● ● ●	● ● ● ● ● ●	● ● ● ● ● ●				
32	33	34	35	36	37	38	39	40	41	42	43
● ● ○ ○ ○ ○	● ● ○ ○ ● ●	● ● ● ● ○ ○	● ● ● ● ● ●	● ● ○ ○ ○ ○	● ● ○ ○ ● ●	● ● ● ● ○ ○	● ● ● ● ● ●	● ● ○ ○ ● ●	● ● ○ ○ ● ●	● ● ● ● ● ●	● ● ● ● ● ●
44	45	46	47	48	49	50	51	52	53	54	55
● ● ○ ○ ● ●	● ● ○ ○ ● ●	● ● ● ● ● ●	● ● ● ● ● ●	● ● ● ● ○ ○	● ● ● ● ● ●	● ● ● ● ○ ○	● ● ● ● ● ●	● ● ● ● ○ ○	● ● ● ● ● ●	● ● ● ● ○ ○	● ● ● ● ● ●
56	57	58	59	60	61	62	63				
● ● ● ● ● ●	● ● ● ● ● ●	● ● ● ● ● ●	● ● ● ● ● ●	● ● ● ● ● ●	● ● ● ● ● ●	● ● ● ● ● ●	● ● ● ● ● ●				

11. Using the DIP switches

DANGER



Wait at least 5 minutes after turning off the power switch and disconnecting the power cord from the wall outlet before opening the face plate of the control box. Touching areas where high voltages are present can result in severe injury.

Note:

- Always be sure to turn the power OFF when changing the settings of the DIP switches.
- The functions of the DIP switches are subject to changes without notification.
- If DIP switches B-1 to B-6 are ON, be sure to check the cylinder movement and data version thoroughly. In some cases a peculiar error may be displayed.

■ DIP switch positions

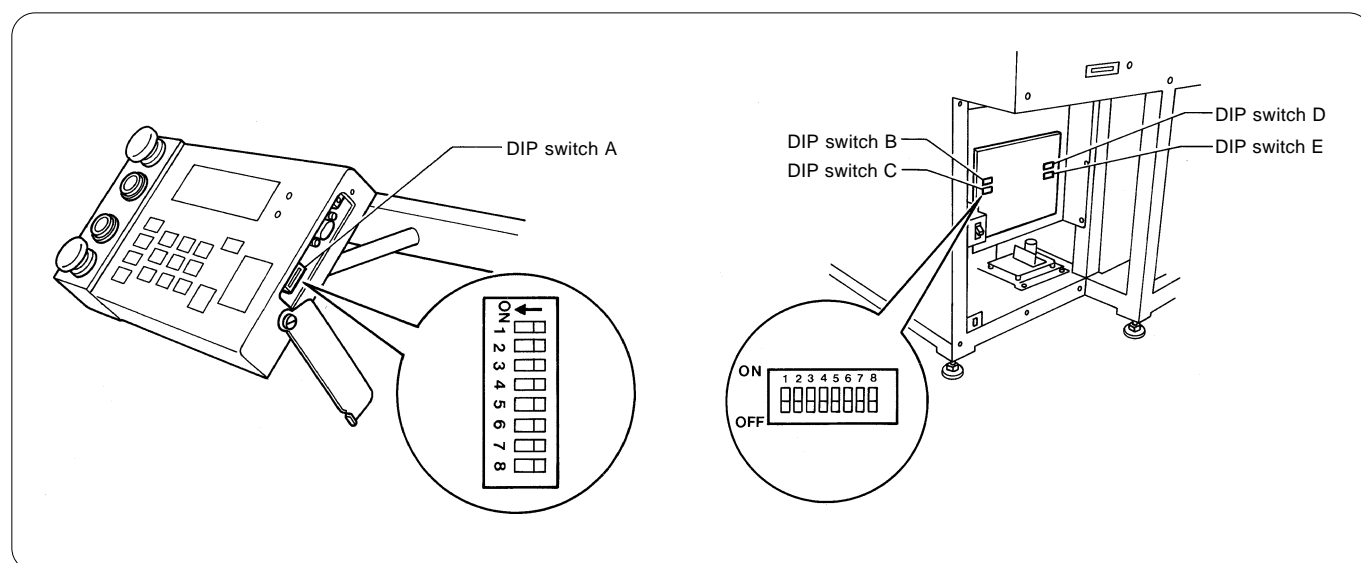

■ Functions of operation panel DIP switches

- DIP switch A

No.	Functions when ON
1	In automatic, pattern matching and label attachment modes, the work clamp stops momentarily before feeding to the home position.
2	Low feeding speed (Machine head → Folder)
3	Low feeding speed (Folder → Machine head)
4	Not available (Should be set to OFF)
5	Not available (Should be set to OFF)
6	Not available (Should be set to OFF)
7	After the power is turned on, three pockets are sewn at 3,000 rpm.
8	Machine head operation check, stacker operation check

■ Functions of DIP switches on main circuit board

- DIP switch B

No.	Functions when ON
1	Mismatches between folder numbers and program numbers are ignored
2	Clamp vertical sensor is ignored
3	Needle racking cylinder sensor is ignored
4	Double cylinder sensor is ignored
5	24 V/36 V power supply voltage check is ignored
6	Single and double clamp data check is ignored
7	Not available (Should be set to OFF)
8	Not available (Should be set to OFF)

• DIP switch C

No.	Functions when ON
1	7 stitches counted before upper thread breakage is detected OFF: 3 stitches counted before upper thread breakage is detected
2	After sewing, the work clamp and machine head return to the previous standby position, even if folding has been completed.
3	Movement to the feed destination occurs immediately when the program data requires it.
4	After sewing, the timer starts 0.2 seconds after the work clamp is raised.
5	Not available (Should be set to OFF)
6	Not available (Should be set to OFF)
7	Not available (Should be set to OFF)
8	Not available (Should be set to OFF)

• DIP switch D

No.	Functions when ON
1	The gauge standby position is always forward. When OFF: The gauge standby position is at the back.
2	Continuous label attachment mode When OFF: Alternate label attachment mode
3	Folder operates at low speed
4	Folder procedure changes
5	Folding is released when base 1.5 is raised
6	Not available (Should be set to OFF)
7	Not available (Should be set to OFF)
8	Not available (Should be set to OFF)

• DIP switch E

No.	Functions when ON
1	Not available (Should be set to OFF)
2	Not available (Should be set to OFF)
3	Not available (Should be set to OFF)
4	Not available (Should be set to OFF)
5	Not available (Should be set to OFF)
6	Not available (Should be set to OFF)
7	Not available (Should be set to OFF)
8	Not available (Should be set to OFF)

12. Table of error code

- If an error occurs which cannot be reset, turn off the power momentarily and eliminate the cause of the problem.
- If an error occurs which can be reset, eliminate the cause of the problem and then press the RESET button.

Error code	Contents	Reset
E – 500	Abnormal rise in 24 V power supply voltage (exceeds +20% of rating)	No
E – 501	Abnormal drop in 24 V power supply voltage (exceeds -20% of rating)	No
E – 502	Abnormal rise in 36 V power supply voltage (exceeds +20% of rating)	No
E – 503	Abnormal drop in 36 V power supply voltage (exceeds -20% of rating)	No
E – 504	Abnormal rise in primary voltage (exceeds +20% of rating)	No
E – 505	Abnormal drop in primary voltage (exceeds -20% of rating)	No
E – 510	Needle bar is not at its highest position at the start of positioning.	Yes
E – 511	Needle bar is not at its highest position at the start of sewing.	Yes
E – 512	Needle bar is not at its highest position during test feeding.	Yes
E – 513	Needle bar is not at its highest position during programming.	Yes
E – 520	Upper thread breakage error	Yes
E – 530	Model and sewing program number do not match.	Yes
E – 535	Retractable are for double (0 to 31) but data does not contain a double switching command.	Yes
E – 536	Model numbers are for single (32 to 63) but data does not contain a single switching command.	Yes
E – 540	Machine head synchronization sensor error or machine head motor error	Yes
E – 550	Needle up stop error	No
E – 560	Presser foot cylinder malfunction or sensor malfunction	No
E – 570	Double sensor error	No
E – 580	Needle racking cylinder malfunction or sensor malfunction	No
E – 600	Machine started with no sewing data	No
E – 700	Error occurred when reading from floppy disk	Yes
E – 701	Error occurred when writing to floppy disk	Yes
E – 710	No sewing data for number specified	Yes
E – 711	Data writing carried out with no sewing data	Yes
E – 720	No disk in floppy disk drive	Yes
E – 730	Floppy disk is write-protected	Yes
E – 740	Insufficient free space on floppy disk	Yes
E – 750	Floppy disk cannot be formatted.	Yes
E – 780	Sewing data exceeds sewing area	Yes
E – 781	No end code in sewing data	Yes

12. Table of error code

Error code	Contents	Reset
E – 800	EMERGENCY STOP button pressed	Yes
E – 801	EMERGENCY STOP button pressed during sewing	Yes
E – 802	EMERGENCY STOP button pressed during programming	No
E – 803	EMERGENCY STOP button pressed during programming	Yes
E – 810	EMERGENCY STOP button is not connected	No
E – 820	No air, or air chuck is turned off	Yes
E – 821	No air, or air chuck is turned off	No
E – 830	X right overtravel switch activated	No
E – 840	X left overtravel switch activated	No
E – 850	Y up overtravel switch activated	No
E – 860	Y down overtravel switch activated	No
E – 870	X motor problem	No
E – 880	Y motor problem	No
E – 890	Machine head motor problem *	No
E – 900	Outer work clamp cylinder malfunction or sensor malfunction	No
E – 901	Inner work clamp cylinder malfunction or sensor malfunction	No
E – 902	Gauge forward/back cylinder malfunction or sensor malfunction	No
E – 903	Base 10 cylinder malfunction or sensor malfunction	No
E – 910	X axis positioning error	No
E – 920	Y axis positioning error	No
E – 960	Clamp-in sensor malfunction	No
E – 970	Clamp malfunction	No

* If the primary-side voltage is lower than the rated level at low temperatures, the error message “E-890” may appear at the sewing start. If this happens, set DIP switch A-7 to ON.

brother[®]

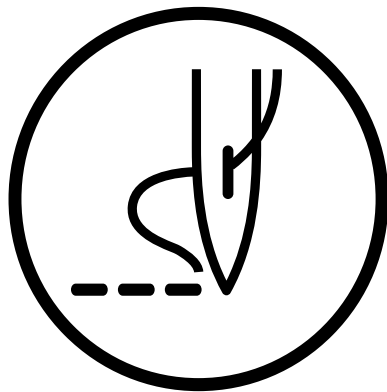

INSTRUCTION MANUAL

BROTHER INDUSTRIES,LTD. NAGOYA,JAPAN

Printed in Japan

151-761
S93761-002
1999.02.B (1)