

LK3-B432EMark II

Electronic Lockstitch Eyelet Buttonhole End Bar Tacker

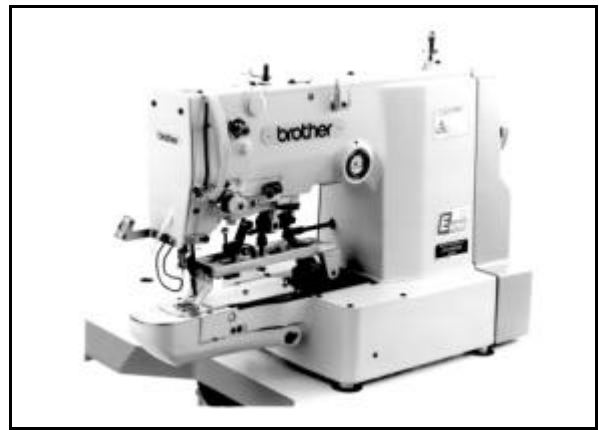



Specifications

Application	Medium materials
Stitch formation	Single needle lock stitch
Max. sewing speed	2,700 rpm
Max. pattern size	Max. 12 × 3 mm
Feed mechanism	R-θintermittent feed mechanism (pulse-motor driven mechanism)
Stitch length	0.1–10.0 mm
No. of stitches	Variable (21, 28, 35 stitches pre-set)
Max. stitch number	20,000 stitches (including 10,000 stitches which can be added)
Work clamp lifter	Solenoid type
Work clamp height	17 mm max.
Hook	Shuttle hook (shuttle hook 2, optional)
Wiper device	Standard equipment
Thread trimmer device	Standard equipment
No. of user programs	16
No. of cycle programs	4
Data storage method	PROM (Any sewing pattern can be added using BAS-PC/300)
No. of stored data	3 sewing patterns are set already. (Up to 100 patterns can be added. Total number of stitches of stored data which can be added is within 10,000.)
Motor	Three-phase 400W induction motor
Weights	Machine head: 47kg, Option panel: 0.6kg, Control box: 9–19kg (depending on destination)
Power supply	Single phase 110, 220–230V Three phase 220, 240, 380, 400V Max. electric power consumption; 600VA

Main use

Bar tacking of eyelet buttonholes for gentlemen's clothes, ladies' clothes and overcoats.

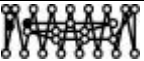
LK3-B432E MarkII List of pre-programmed patterns

No. Program No.	Sewing pattern	No. of stitches	Pattern size X-Y (mm)
01		21	6 × 2
02		28	6 × 2
03		35	6 × 2

Optional device Thread take-up mechanism

< デニム用 (B430E, B433E) / For Denim (B430E, B433E) >

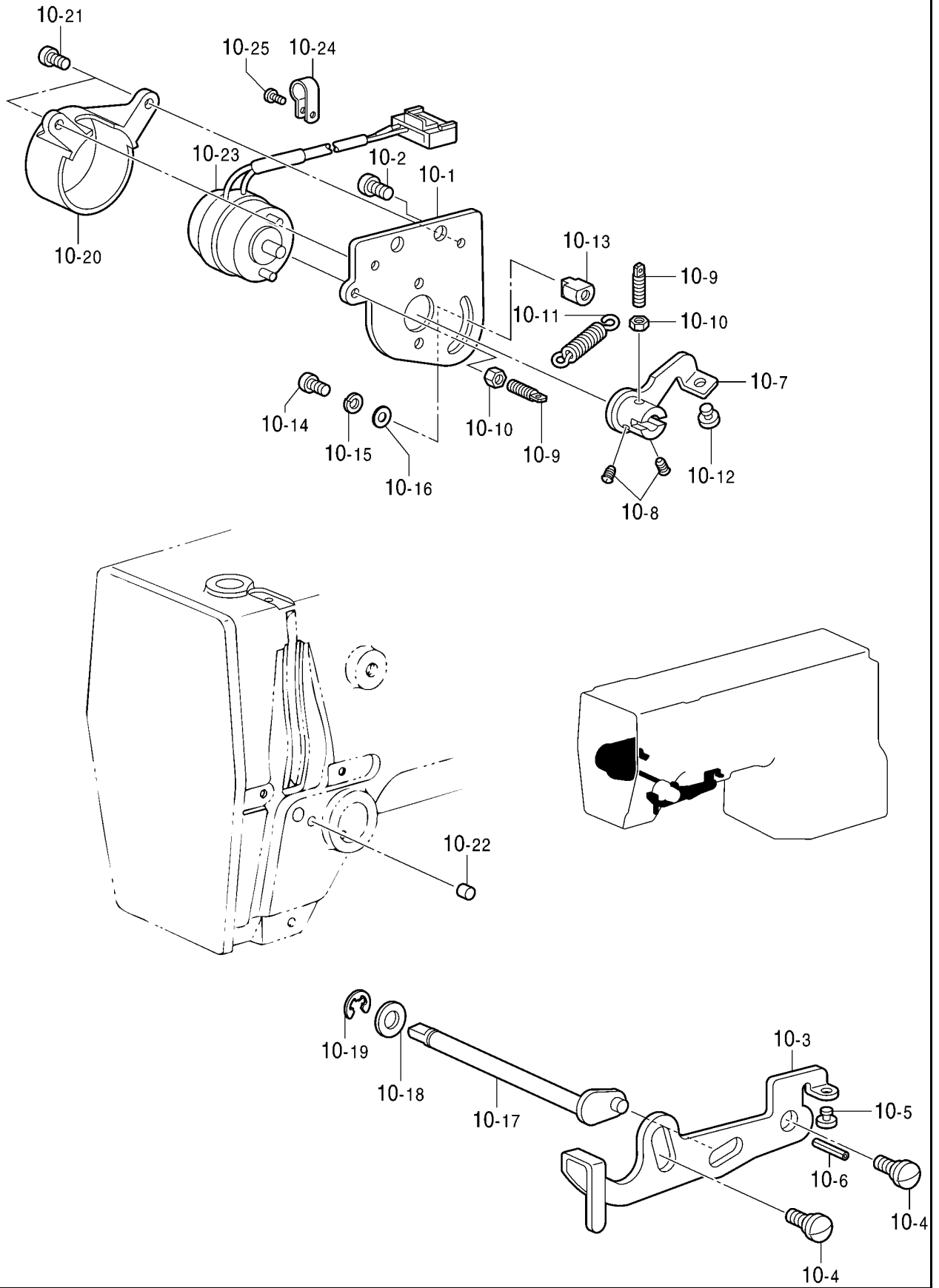





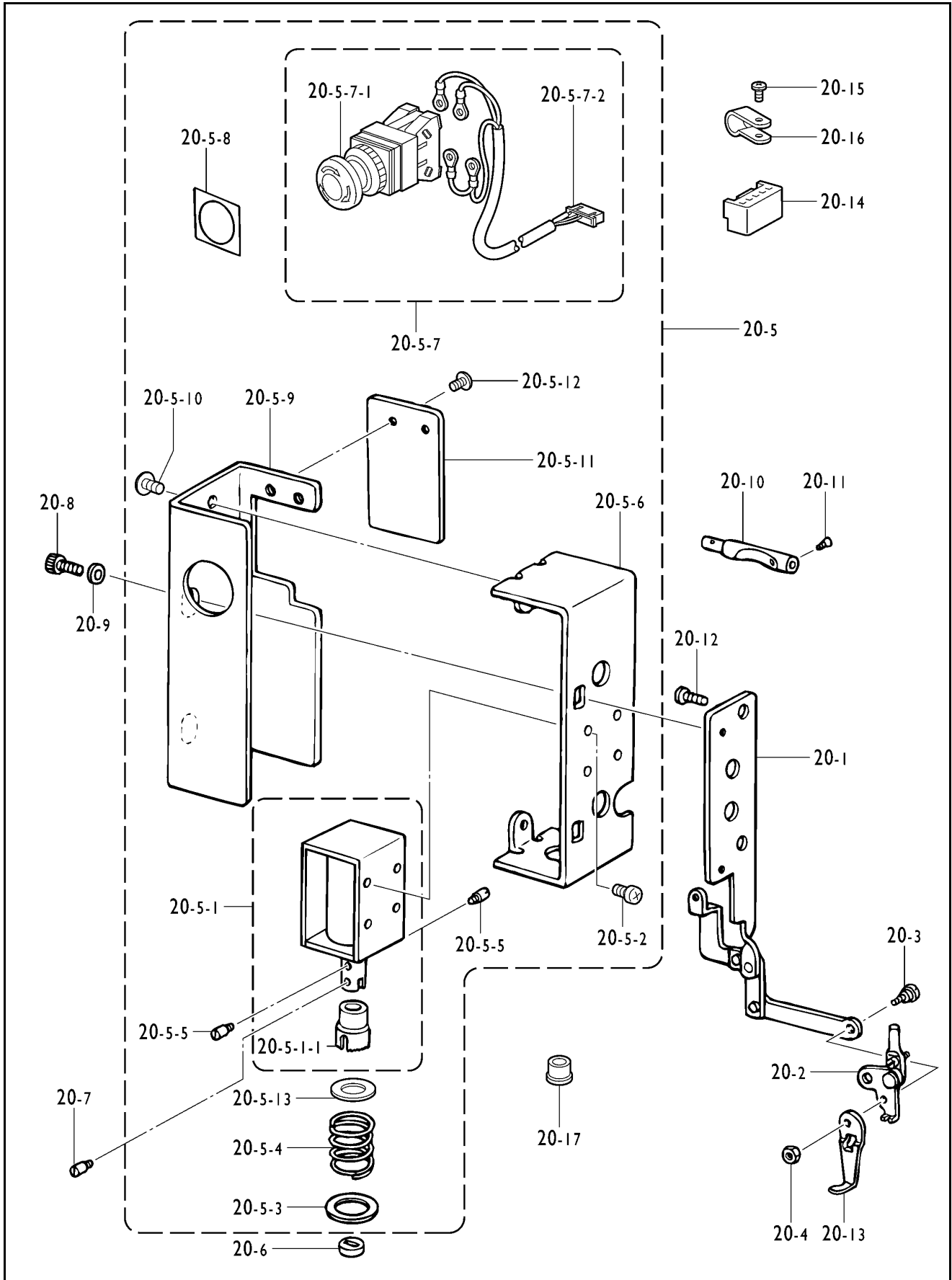









Ref. No.	Part name	Part code	Q'ty
<Option parts for Denim>			
10	Thread take-up device	S49956-001	1
10-1	Solenoid setting plate	S49659-001	1
10-2	Screw, pan SM4.76 – 32×8	062710-812	2
10-3	Thread take-up lever	S49660-001	1
10-4	Shoulder screw, SM4.76	107321-003	2
10-5	Differential crank cushion	S19748-001	1
10-6	Pin, spring roll AW4	047401-442	1
10-7	Thread trimming solenoid joint	S49661-001	1
10-8	Set screw, SM3.57	S01998-001	2
10-9	Spring hook	110251-001	2
10-10	Nut, 1 SM3.57	021670-102	2
10-11	Thread trimmer spring	S34883-001	1
10-12	Differential crank cushion	S19748-001	1
10-13	Nut, SM3.57	S49663-001	1
10-14	Screw, pan SM3.57 – 40×10	062671-012	1
10-15	Washer, spring 2 - 3.5	028350-242	1
10-16	Washer, plain L3.5	025350-332	1
10-17	Crankshaft	S49662-001	1
10-18	Washer, plain	155559-001	1
10-19	Retaining ring, E4	048040-342	1
10-20	Thread take-up solenoid cover	S49664-000	1
10-21	Screw, pan SM3.57 – 40×8	062670-812	2
10-22	Rubber cap, 5.3	S20878-000	1
10-23	Thread take-up solenoid	S49464-000	1
10-24	Cord holder, 5N	S00480-000	3
10-25	Screw, bind SM3.57 – 40×6	060670-612	3

**Optional device
Solenoid thread wiper**



Ref. No.	Part name	Part code	Q'ty
20	Thread wiper solenoid assy	S49615-009	1
20-1	Thread wiper connect rodassy	S41656-001	1
20-2	Thread wiper armassy	S44600-001	1
20-3	Shoulder screw, SM3.57	153112-001	1
20-4	Nut, 2 SM3.57	021670-202	1
20-5	Solenoid box assy	S49616-009	1
20-5-1	Thread wiper solenoid assy	S49619-001	1
20-5-1-1	Plunger rubber	S41204-050	1
20-5-2	Screw, pan M3 x 6	062300-612	4
20-5-3	Washer, plain	S41205-001	1
20-5-4	Spring, t-wiper	S41206-001	1
20-5-5	Plunger pin	S25456-001	2
20-5-6	Setting plate, W-sol.	S42017-109	1
20-5-7	EM-lock switch harness assy	S49482-000	1
20-5-7-1	Switch, AVS311N	S32335-000	1
20-5-7-2	EM-switch harness	S49466-000	1
20-5-8	EM-switch spacer, 3	S37057-001	1
20-5-9	Solenoid cover, W	S42018-109	1
20-5-10	Screw, truss M4 x 6	008400-604	2
20-5-11	Solenoid cover lid, E	S37806-109	1
20-5-12	Screw, truss M4 x 6	008400-604	2
20-5-13	Washer, plain 13	115007-001	1
20-6	Spacer rubber	S41207-000	1
20-7	Plunger pin	S25456-001	1
20-8	Bolt, socket M4 x 6	018400-632	2
20-9	Washer	100645-003	2
20-10	Tension release rod, DW	S41657-001	1
20-11	Screw, flat M3.5 x 6	061350-616	1
20-12	Screw, pan SM4.37-40 x 8	062680-812	2
20-13	Thread wiper, A	156206-001	1
20-14	Connector	S49947-000	1
20-15	Screw, bind SM3.57-40 x 6	060670-612	3
20-16	Cord holder, 7N	149287-000	3
20-17	Rubber cap, 15.5	104449-009	1

Different parts list

		B432E MarkII
Needle hole plate		(φ2.2) S49980-001 FM
Bobbin case assy		159610-201 A ◎
		S15902-401 LA ○
Tensionspring		154339-001 A ◎
		S16074-101 LA ○
Screw		154341-001 ◎
		S16492-101 LA ○
Spring, anti-spin		159612-001 A ◎
		S15667-001 LA ○
Bobbin		159613-051 ◎
		S15665-001 LA ○
Shuttle hook box assy		152685-903 A ◎
		S15662-992 LA ○
Large shuttle hook		152682-101 A ◎
Spring, tension		104525-001 ◎
Spring		145519-001 ◎
Thread guide, needle bar	  A B	S41222-001 B ◎
Needle assy		107415-414
Needle		DP×5 #14 107415-014
Feed plate		432 S51084-001

*◎: Common with the LK3-B430E.

○: Common with the BAS-311E.

Standard parts

Standard size for work clamps and feed plates are as follows:

(The actual sewing area has 1.5 mm margin on every size; inside the lines which the dimensions indicate.)

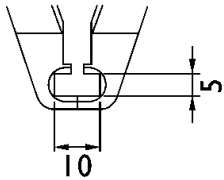
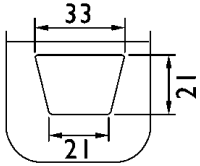
Model	B432E Mark II
R	118249-001
L	118250-001
Work clamp	
Feed plate	S51084-001
	

Standard needle hole plates are as follows.

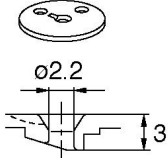
Model	B432E Mark II	
	FM	S49980-001
Needle hole plate		

Gauge parts list (Optional parts)

Needle hole plate

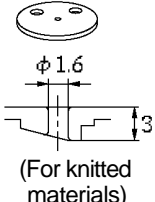
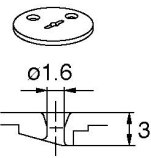
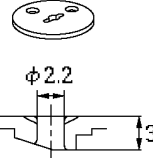
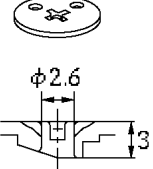
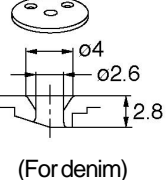
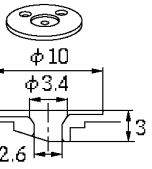
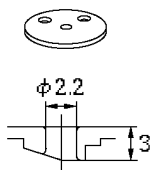
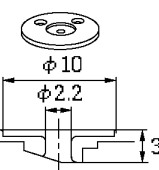
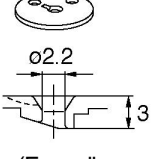
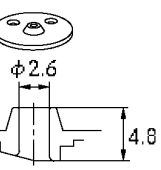
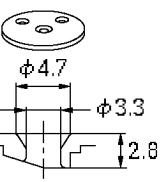
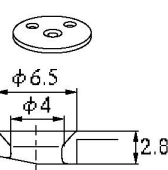
A	S10211-001	AF	S51449-001	BZ	S41013-001	D	S29997-001	E	S10212-101	ED	S30925-001	
						(For knitted materials)						(For denim)
F	S10213-001	FD	S30926-001	FM	S49980-001	H	S30450-001	L	S25127-001	M	S34348-001	
						(For ordinary materials)						