

JUKI

**1-Needle, Unison-feed, Lockstitch Machine
with an Automatic Thread Trimmer**

DNU-241H-5-2B

ENGINEER'S MANUAL

CONTENTS

1. SPECIFICATIONS	1
2. STANDARD ADJUSTMENTS OF THE MAIN UNIT	2
1) Height of the needle bar	2
2) Timing relationship between the needle and hook	2
3) The height and longitudinal position of the feed dog	4
4) Timing of the cloth feed action	6
5) Top feed movement	8
6) Top feed differential	10
7) Timing of the top feed cam	12
8) Lubrication (hook)	12
3. STANDARD ADJUSTMENTS OF ADDITIONAL DEVICES	14
1) Thread trimmer	14
(a) Timing of the thread trimming	14
(b) Position of the rotary knife	16
(c) Position of the needle thread retaining spring	20
(d) Position of the thread trimming cam	20
(e) Thread trimmer solenoid	22
(f) Pressure of the counter knife	24
2) Automatic reverse feed device	24
4. ASSEMBLY/DISASSEMBLY OF THE THREAD TRIMMER COMPONENTS	26
5. MOTOR	28
1) Synchronizer	28
2) Machine start, end back, and soft start	28
3) Selecting the soft start function	30
4) Sewing speed for reverse stitching	30
5) Thread trimming speed	30

6. LIST OF REPLACEMENT PARTS	32
7. PARTS TO BE APPLIED WITH LOCK-TITE PAINT	32
8. OPTIONAL PARTS	32
9. TROUBLESHOOTING (Mechanical parts)	33
10. TROUBLESHOOTING (Sewing condition)	34
11. TROUBLESHOOTING FOR THE ADDITIONAL DEVICES	36
12. POSITION TO FIX THE KNEE LIFTER	39
13. TABLE DIAGRAM	39

1. SPECIFICATIONS

No.	Item	Specification
1	Model number	DNU-241H-5-2B
2	Model name	1-needle, unison-feed, lockstitch machine with an automatic thread trimmer
3	Application	Ordinary fabrics, vinyl leather, leather Medium heavy- to heavy-weight material
4	Sewing speed	Max. 2,400 s.p.m.
5	Needles	DP x 17 #23
6	Thread	#40 to #8
7	Stitch length (normal x reverse)	8 mm x 8 mm
8	Lift of the presser foot	Hand lifter 9 mm, Knee lifter 15 mm
9	Stitch length adjusting mechanism	By a wedge-type dial
10	Reverse stitch selection method	Magnetic outside mounted type (Touch-back type)
11	Thread take-up	Slide type
12	Needle bar stroke	38 mm
13	Vertical stroke of the top feed dog	3 to 6 mm
14	Hook	Horizontal, double-capacity, fully rotational, self-lubricating hook
15	Feed mechanism	Forked link oscillation method
16	Top feed mechanism	Linked to the bottom feed
17	Top and bottom feed actuation mechanism	By bevel gear
18	Lubrication	Manual lubrication Self-lubricating hook with a tank
19	Thread trimming mechanism	Oscillating knife on the end of the hook, scissors type
20	Disk floating mechanism	By the outside-mounted magnet
21	Lubrication oil	New Defrix Oil No. 1
22	Bed size	178 mm x 476.6 mm
23	Depth of the sewing area	264 mm
24	Motor	2P-400W
25	Conducting belt	M-type V-belt

2. STANDARD ADJUSTMENTS OF THE MAIN UNIT

1) Height of the needle bar

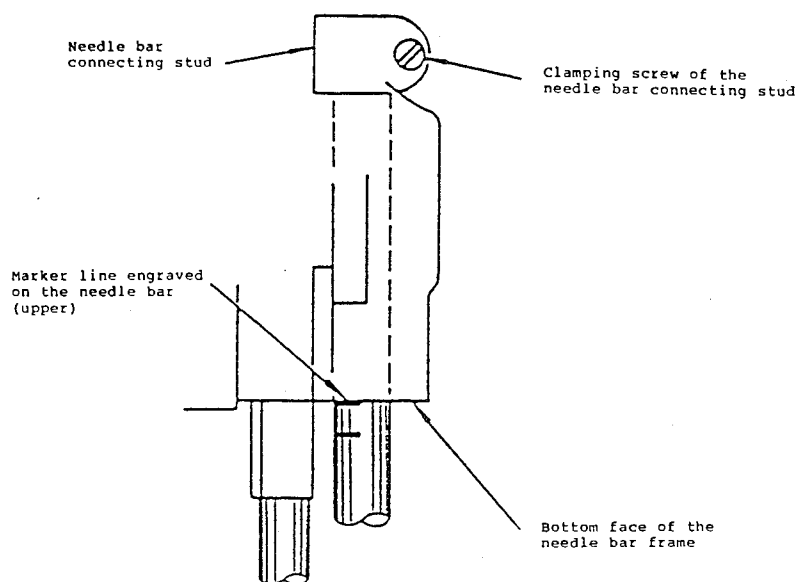

<Conditions>

- o The needle bar is at its lowest position.
- o Set the dial to 0.

2) Timing relationship between the needle and hook

(1) Lift amount of the needle, and the position of the needle and blade point of the hook

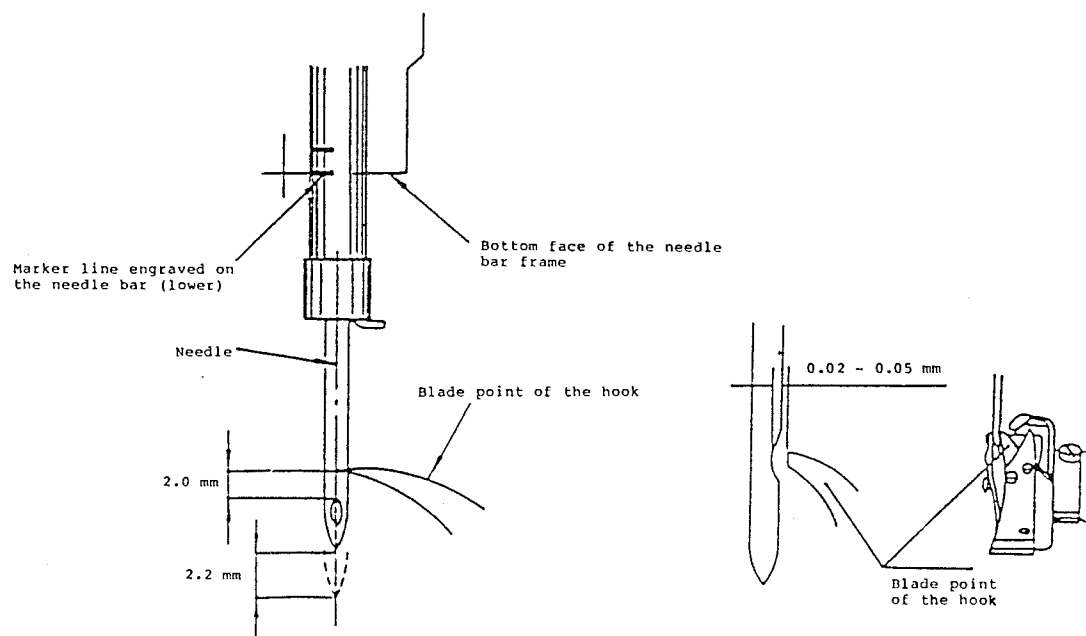

<Conditions>

- o The needle bar goes up from the lowest position of its stroke.
- o Set the dial to 0.

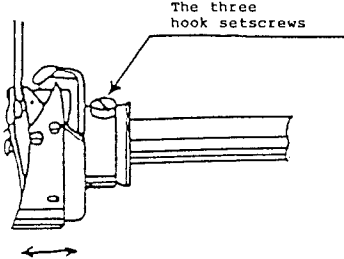
HOW TO ADJUST	RESULTS OF IMPROPER ADJUSTMENT
<ol style="list-style-type: none"> 1. Turn the handwheel so that the needle bar reaches the lowest dead point of its stroke. 2. Loosen the clamping screw of the needle bar connecting stud. 3. Align the needle bar with the engraved upper marker line, and tighten the clamping screw of the needle bar connecting stud. <p>(Caution) Use the marker line engraved on the needle bar only as a reference point when adjusting the distance between the needle and the blade point of the hook. Note that the distance between the upper end of the needle eyelet and the blade point of the hook should be 2.0 mm when the center of the needle is aligned with the blade point of the hook.</p>	<ul style="list-style-type: none"> o Stitch skipping or thread breakage might occur if the distance between the needle and the blade point of the hook is not properly adjusted.
<ol style="list-style-type: none"> 1. Loosen the throat plate setscrew and remove the throat plate. 2. Raise the needle bar by 2.2 mm from its lowest dead point. 3. To adjust the clearance between the needle and the blade point of the hook, loosen the hook setscrews, move the hook in the direction of the arrow until the specified clearance is obtained, and then tighten the setscrew. 4. To adjust the position of the needle and the blade point of the hook, loosen the hook setscrews and turn the hook by hand until the center of the needle is aligned with the blade point of the hook. <div style="text-align: center;">  <p>The three hook setscrews</p> </div>	<ul style="list-style-type: none"> o Irregular stitches, stitch skipping or thread breakage. ● Irregular stitches such as isolated idling loops will be observed if the hook timing is too early or too late. ● Irregular stitches may be prevented if the hook timing is set so that it is relatively late. ● If the hook timing is set late, the thread tension will be decreased. ● Any isolated idling loops in lockstitching will be eliminated if the hook timing is set earlier. o The needle thread may fail to be trimmed.

3) The height and longitudinal position of the feed dog

(1) Height of the feed dog

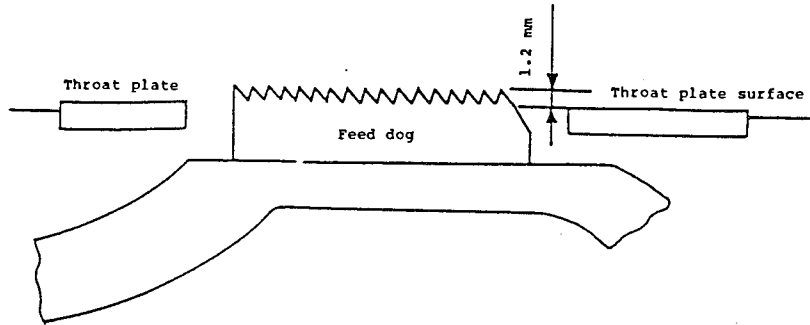

<Conditions>

- o The feed amount is set to 0.
- o The section of the feed dog protruding most should be 1.2 mm higher than the surface of the throat plate.

(2) Longitudinal position

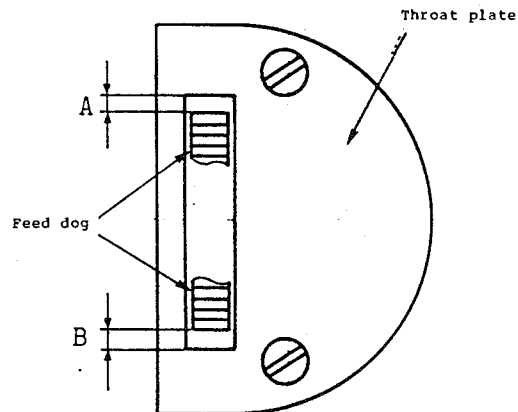

<Conditions>

- o Feed amount: Max. 8 mm
- o Longitudinal clearances A and B between the feed dog and throat plate should be equal (for both cases of normal feeding and reverse feeding).

HOW TO ADJUST

1) Height of the feed dog

1. Set the feed regulating dial to 0.
2. Turn the handwheel until the amount of protrusion of the feed dog from the throat plate is maximized.
3. Loosen the clamping screw of the vertical feed forked connector and move the vertical feed forked connector up and down so that the feed dog is 1.2 mm higher than the surface of the throat plate. Then tighten the clamping screw.

2) Longitudinal position

1. Set the feed regulating dial to 8.
2. Loosen the feed rocker clamping screw and adjust so that the feed dog moves evenly with regard to the groove in the throat plate. Then tighten the feed rocker clamping screw.

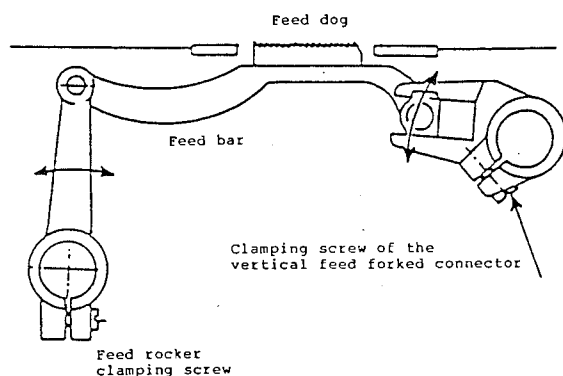

RESULTS OF IMPROPER ADJUSTMENT

If the feed dog is positioned too high:

- o The feed dog may come in contact with the throat plate.
- o The stitch length may actually be larger than the value set by the feed regulating dial.
- o Irregular stitches may be observed.

If the feed dog is positioned too low:

- o The stitch length may actually be smaller than the value set by the feed regulating dial.
- o The feed force may be decreased.
- The counter knife may come in contact with the feed dog.

Longitudinal position

- o As the throat plate comes in contact with the feed dog and the feed rocker comes in contact with the bed, an abnormal noise may be heard.
- o If amount B is inadequate, the counter knife might come in contact with the needle when the feed amount and sewing speed are set to their maximum values.

4) Timing of the feed action

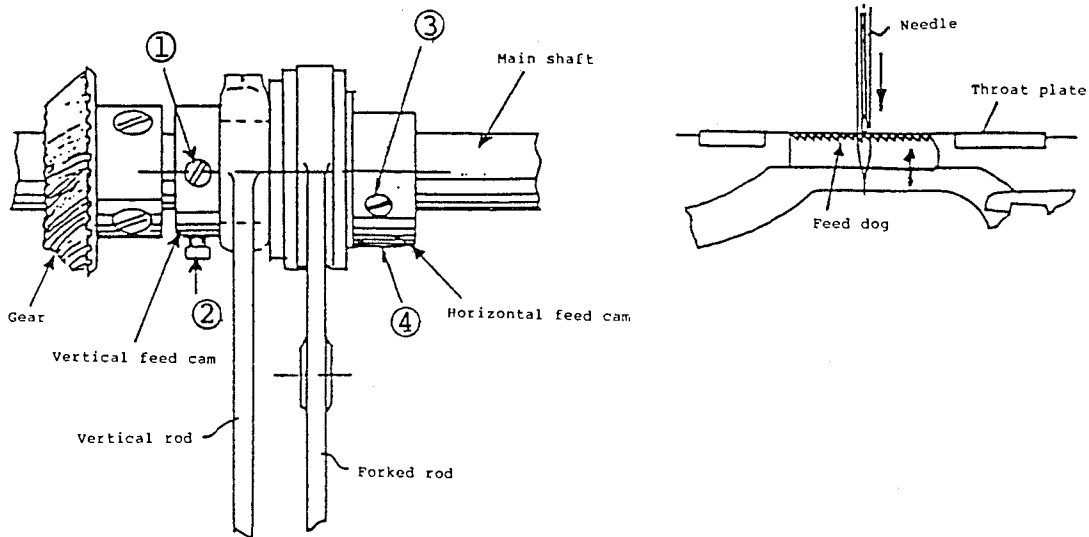

<Conditions>

- o Feed amount: 8 mm
- o The lower end of the needle eyelet should be aligned with the surface of the throat plate when the center of the feed dog is also aligned with the surface of the throat plate.
- o When the needle bar goes up by 1.2 mm from the lowest dead point of its stroke, the feed dog will not move even if the lever is lowered.

HOW TO ADJUST

- 1) Vertical feed cam
 1. Loosen setscrews ① and ② of the vertical feed cam.
 2. Turn the vertical feed cam and adjust so that the following three points are aligned: the surface of the throat plate, the lower end of the needle eyelet, and the tip of the feed dog (at the center section).
- 2) Horizontal feed cam
 1. Loosen setscrews ③ and ④ of the horizontal feed cam.
 2. Turn the horizontal feed cam until the feed dog no longer moves with the lever lowered when the needle bar goes up by 1.2 mm from the lowest position of its stroke.
 3. Make sure that the top feed does not move backward. Then tighten the setscrews.

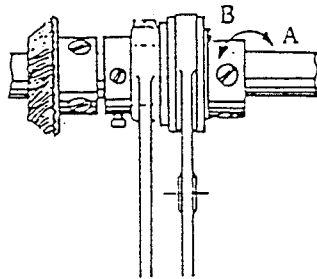

(Caution)

If the cam has been adjusted so that it is moved out of its correct position toward the shaft, smooth cam operation may be hindered.

RESULTS OF IMPROPER ADJUSTMENT

Vertical feed cam

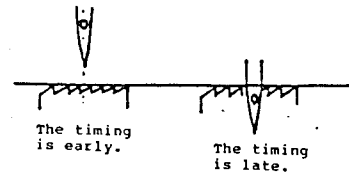

If the timing of the vertical feed cam is too early:

- o Isolated idling loops may be eliminated, but loose stitches may occur.

If the timing of the vertical feed cam is too late:

- o Irregular stitches may be caused, although any loose stitches may be eliminated.
- The needle may break.

The feed dog movement will be changed in accordance with the standard adjustment shown in the figure.

Horizontal feed cam

The stitch length during normal feed or reverse feed may not be of the value set. Irregular stitches may occur.

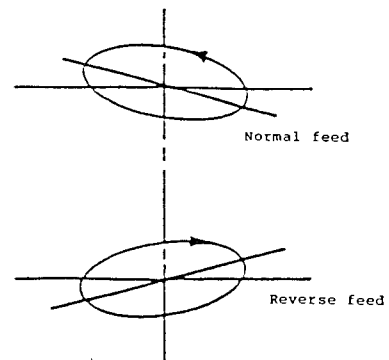

5) Top feed movement

(1) Longitudinal position of the walking foot

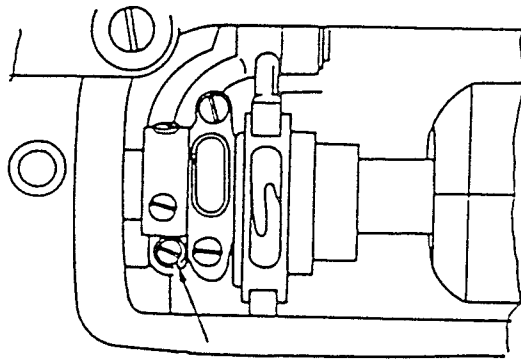

Clamping screw of the rear crank of the frame rocking shaft

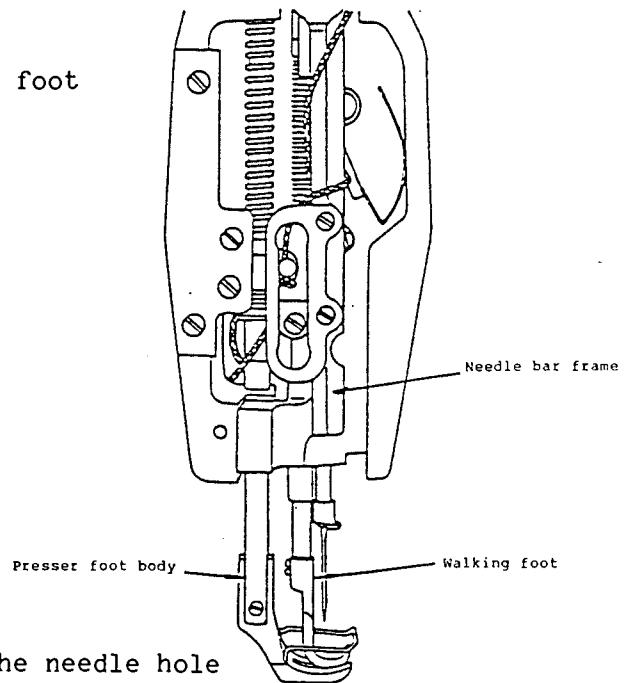

<Conditions>

- o Set the dial to 8.
- o The needle should be aligned with the needle hole in the feed dog.

(2) Alternate momentum

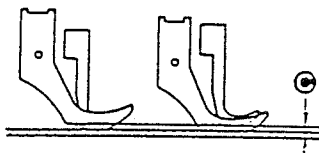

C: equal

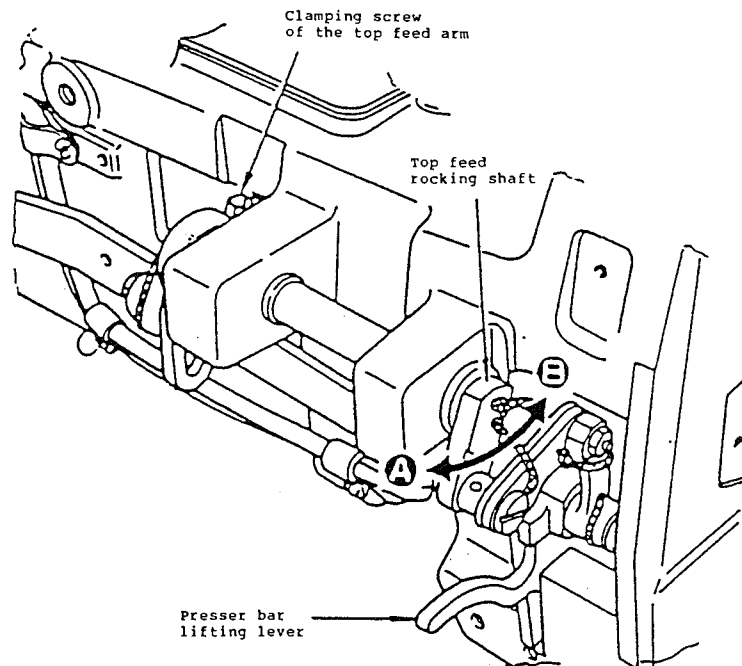

<Conditions>

- o Feeding amount: 0
- o The alternate momentum of the walking foot and presser foot should be equal.

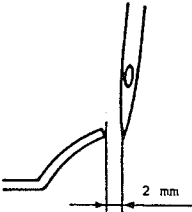
HOW TO ADJUST	RESULTS OF IMPROPER ADJUSTMENT
<ol style="list-style-type: none"> 1. Set the dial to the maximum value (8 mm). 2. Loosen the clamping screw of the rear crank of the frame rocking shaft. 3. Lower the needle bar. Move the needle bar frame so that the needle enters the center of the needle hole in the feed dog. Then firmly tighten the clamping screw. <p>(Caution)</p> <ol style="list-style-type: none"> 1. Check the distance between the presser foot and the walking foot. 2. The clearance between the counter knife and the needle should be 2 mm or more with the dial set to 8. 	<ul style="list-style-type: none"> o If the longitudinal position of the walking foot is significantly different from its correct position. o The walking foot components may come in contact with each other, resulting in abnormal operating noise. o The counter knife may come in contact with the needle, and both may break.
<ol style="list-style-type: none"> 1. Remove the top feed front cover and open the top feed rear cover. 2. Turn the handwheel by hand until the thread take-up reaches the lowest position of its stroke. 3. Lower the presser bar lifting lever. 4. Loosen the clamping screw of the top feed arm. 5. Move the top feed shaft in direction (A). The vertical stroke of the walking foot will be decreased, while that of the walking foot will be increased. 6. Move the top feed shaft in direction (B). The vertical stroke of both the walking foot and the presser foot will be equal. 	<ul style="list-style-type: none"> o Adjust the vertical stroke of the walking foot so that it is larger than that of the presser foot in accordance with the type of material to be sewn. <ul style="list-style-type: none"> o Sewing sponge material o Sewing material with overlapped sections o Piping material o If the alternate vertical strokes of the walking foot and presser foot are considerably different: <ul style="list-style-type: none"> ● The stitch length may actually be different from the value set by the dial. ● The feed efficiency may be decreased. The rate of rotation of the motor must therefore be decreased.

(3) Alternate vertical momentum

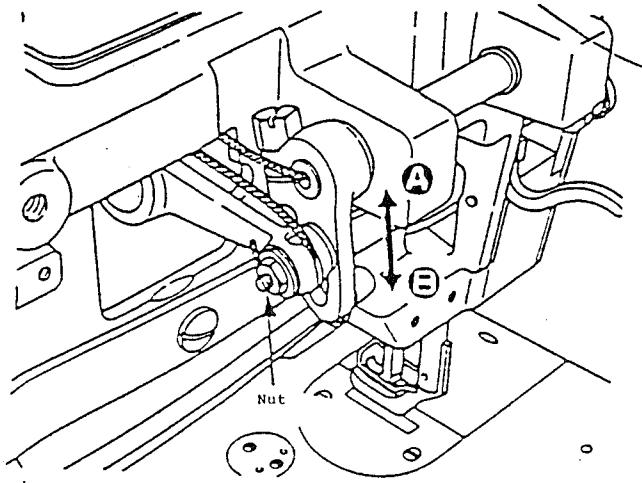

<Condition>

- o Align the boss with the 1/8 engraved marker dot.

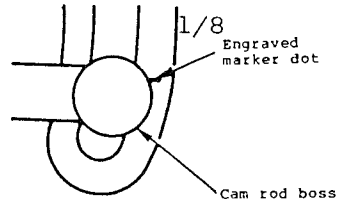

6) Top feed differential

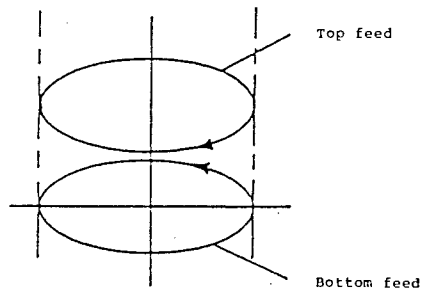
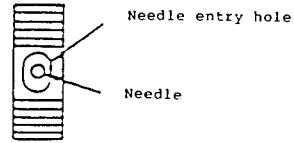
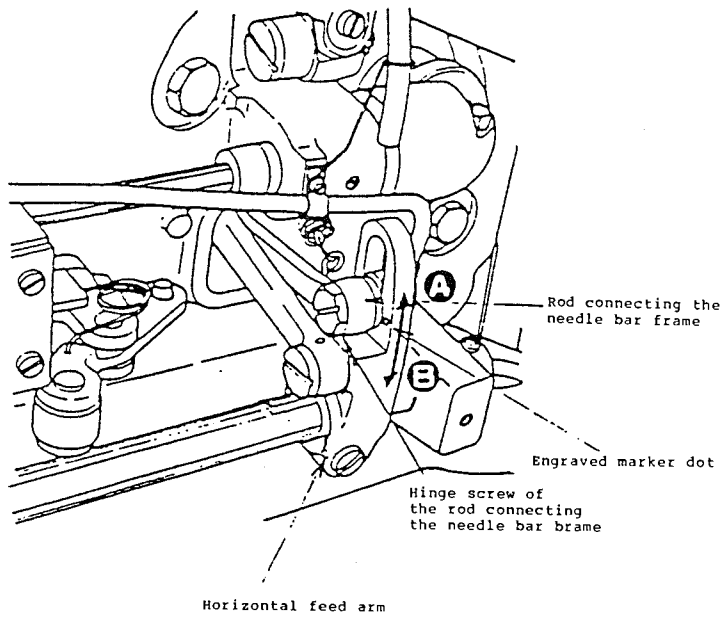

<Standard conditions>

- o The center of the boss of the rod connecting the needle bar frame is aligned with the marker dot engraved on the horizontal feed arm.
- o The ratio of the bottom feed amount to the top feed amount is 1 : 1.

HOW TO ADJUST	RESULTS OF IMPROPER ADJUSTMENT
<ol style="list-style-type: none"> 1. Loosen the screw nut connecting the top feed rod. 2. Adjust the position of the boss on the cam rod by moving the boss up or down. Then tighten the screw nut. <ul style="list-style-type: none"> o If the boss is fixed in the upper section of the long hole (15/64): Amount of movement: Max. 6 mm o If the boss is fixed in the lower section of the long hole (1/8): Amount of movement: Min. 3 mm 	<ul style="list-style-type: none"> o Change the amount of movement in accordance with the type of material to be sewn. <ul style="list-style-type: none"> o Sewing sponge material or the like o Sewing material with overlapped sections <p>If the amount of movement is adjusted so that it is too large:</p> <ul style="list-style-type: none"> ● The stitch length may actually be different from the value set by the dial. ● The feed efficiency may be decreased. The rate of rotation of the motor must therefore be decreased.
<ol style="list-style-type: none"> 1. Loosen the hinge screw of the rod connecting the needle bar frame. 2. Move the connecting rod of the needle bar frame and adjust so that the center of the boss of the rod connecting the needle bar frame is aligned with the marker dot engraved on the horizontal feed arm. 3. Use a wrench to firmly tighten the hinge screw of the rod connecting the needle bar frame. <p>(Caution) Adjust the position of the connecting rod of the needle bar frame inside the needle hole in the feed dog.</p>	<div data-bbox="1019 911 1386 1100" data-label="Image"> </div> <ul style="list-style-type: none"> o If the connecting rod of the needle bar frame is moved in the direction of the arrow, the amount of movement of the walking foot will be increased. <div data-bbox="1062 1394 1338 1680" data-label="Diagram"> </div> <ul style="list-style-type: none"> o Change the position of the connecting rod of the needle bar frame in accordance with the sewing conditions.

7) Timing of the top feed cam

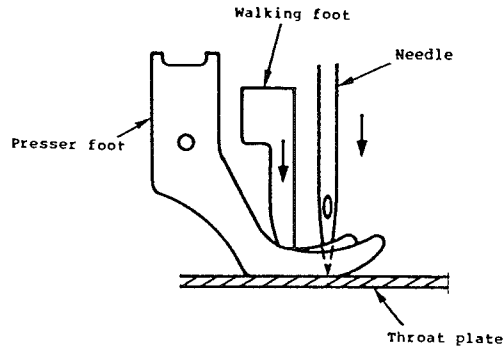

<Condition>

- o The walking foot is aligned with the surface of the feed dog when the needle comes down and the tip of the needle reaches the surface of the throat plate.

8) Lubrication (hook)

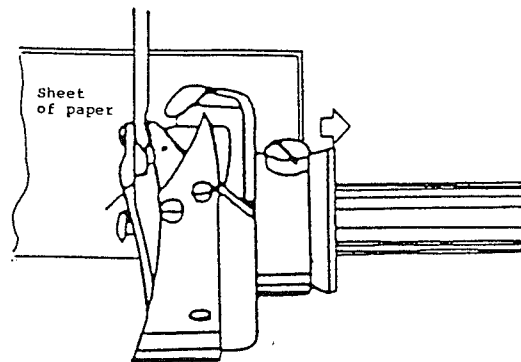
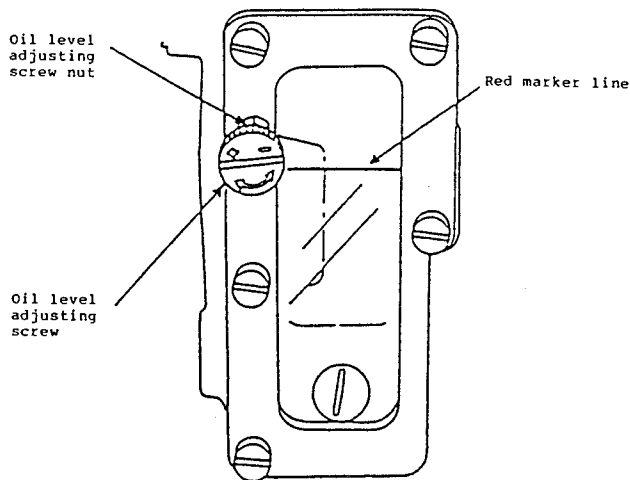

(Caution)

Fill the oil tank with oil up to the red marker line.

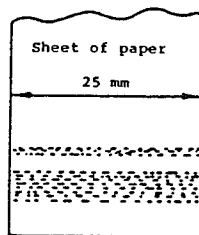

Appropriate amount of oil in the hook

<Conditions>

- o Sewing speed: 2,000 s.p.m.
- o After the sewing machine has been idling for 30 seconds, splash oil should begin collecting in lines on a sheet of paper placed 10 mm away from the peripheral of the hook, lasting for five seconds.
- o Set the dial to 3.

HOW TO ADJUST

1. Loosen the two setscrews of the top feed cam.
2. Turn the top feed cam until the surface of the throat plate, the tip of the needle, and the walking foot (presser face) are aligned with each other. Then tighten the two setscrews of the top feed cam so that the top feed cam is firmly fixed in that position.

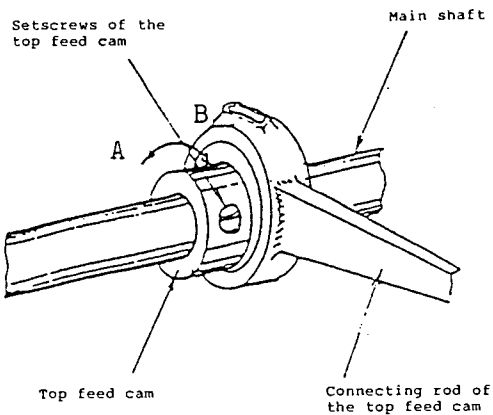

RESULTS OF IMPROPER ADJUSTMENT

- o If the timing of the top feed cam is too early (when the top feed cam is moved in direction A):

- o Loose stitches may be observed.
- o The stitch length may actually be different from the value set by the dial (smaller than the set value).
- o The feed foot may be forced to move in the opposite direction.

- o If the timing of the top feed cam is too late (when the top feed cam is moved in direction B):

- o Loose stitches may be observed.
- o The needle thread is likely to finely split.
- o The stitch length may actually be different from the value set by the dial (larger than the set value).

Adjusting the amount of oil to be supplied to the hook

- o The maximum amount of oil will be supplied to the hook when the oil level adjusting screw is tightened until it will go no further. (The screw is turned in the clockwise direction +.)
1. Loosen the oil level adjusting screw nut.
 2. Turn the oil level adjusting screw and adjust so that the appropriate amount of the oil is supplied to the hook. Then tighten the nut on the oil level adjusting screw.

- o If the amount of oil to be supplied to the hook is inadequate, loose stitches may be formed. The hook might generate heat and is likely to quickly wear out resulting in a burned out hook. Furthermore, an insufficient supply of oil to the hook may cause irregular stitches.
- o On the other hand, if too much oil is supplied to the hook, the thread or material may become stained with oil.

3. STANDARD ADJUSTMENTS OF ADDITIONAL DEVICES

1) Thread trimmer

(a) Timing of the thread trimming

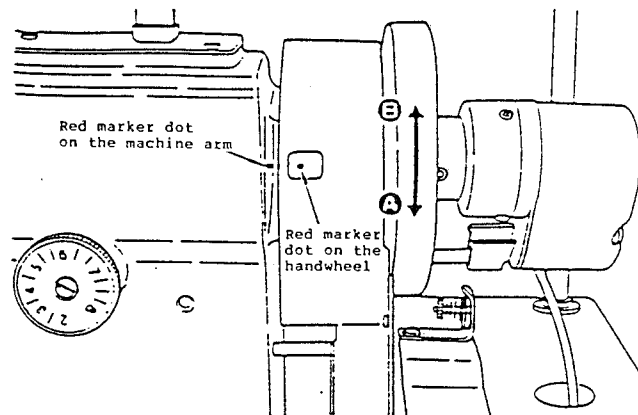
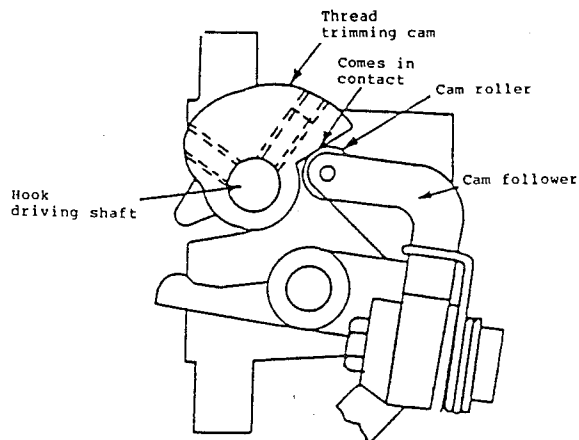

<Conditions>

- o The red marker dot on the machine arm is aligned with the red marker dot on the handwheel when the needle bar comes slightly down from the highest dead point of its stroke and the flat section of the thread trimming cam lightly touches the cam roller.

(Caution)

As the thread trimming cam is mounted on the hook driving shaft, it rotates twice while the handwheel rotates once.

HOW TO ADJUST

1. Loosen the two setscrews of the thread trimming cam.
2. Align the red marker dot on the handwheel with the red marker dot on the machine arm.
3. Adjust the position of the thread trimming cam so that the flat section of the thread trimming cam comes in contact with the cam roller when the rotary cam is in the start position. In this state, fix the thread trimming cam in place.

(Caution)

Be sure to firmly tighten the two setscrews of the thread trimming cam. If they become loose, it may result in faulty thread trimming or knife breakage.

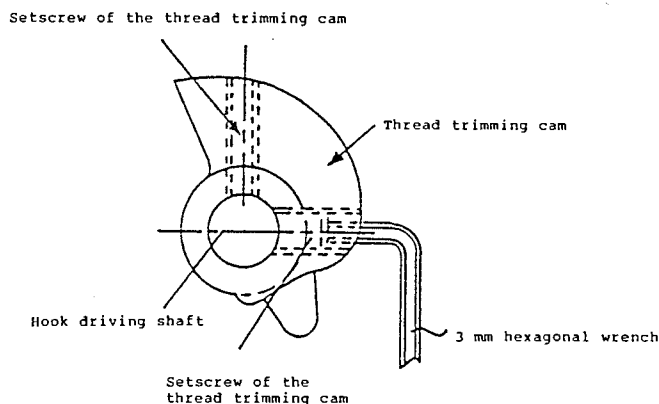

RESULTS OF IMPROPER ADJUSTMENT

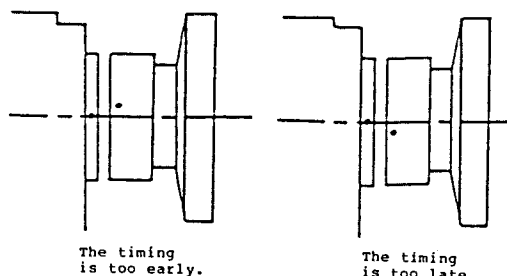

If the timing of the thread trimmer is too early:

- o The needle thread remaining in the needle may be too short.
- o The needle thread may slip off the needle eyelet. (The thread trimming knife may be actuated twice.)

If the timing of the thread trimmer is too late:

- o The needle thread remaining in the needle may be too long.
- o The clearance between the throat plate and the tip of the needle may be decreased when the machine stops with the needle up.
- If the thread trimmer is actuated twice or the thread remaining in the needle is too short, adjust the timing of the thread trimmer so that it is a little late. On the other hand, if the thread remaining in the needle is too long, adjust the timing of the thread trimmer so that it is a little early. As a general rule, adjust the timing of the thread trimmer so that it is early if thin thread is used, on late in the case of thick thread.

(Caution)

- o The distance between the red marker dot on the handwheel and the red marker dot on the machine arm should not exceed 7° (5 mm) when the timing of the thread trimmer has been adjusted.

If the timing of the thread trimmer is adjusted so that it is late, adjust the needle-up stop position by means of the synchronizer.

(b) Position of the rotary knife

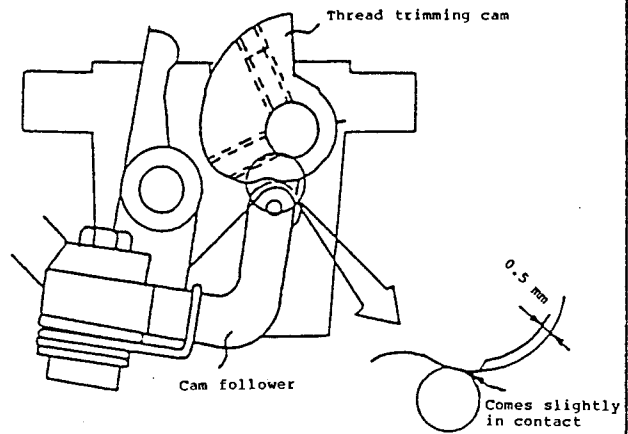
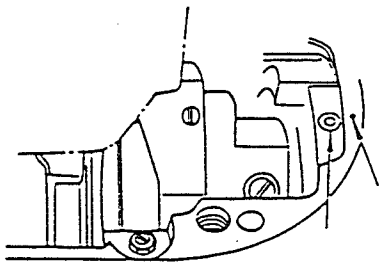

<Conditions>

o Normal condition

(The stopper plate comes in contact with the knife driving arm.) At this time, the lubrication hole in the rotary knife mounting base is aligned with the marker dot engraved on the machine bed.

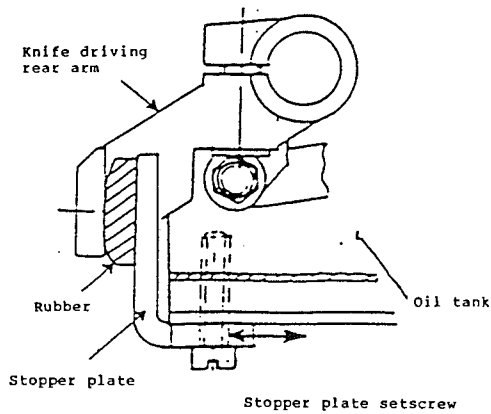
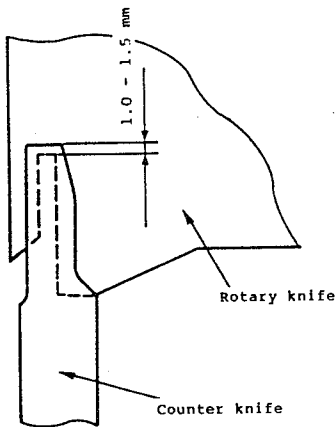

<Conditions>

o The amount of engagement of the rotary knife with the counter knife is 1.0 to 1.5 mm when the rotary knife reaches its forward end.

- o The cam roller comes in light contact with the standing edge of the cam when the stopper plate also comes in light contact with the knife driving rear arm.
- o The clearance between the periphery of the cam and the cam roller should be 0.5 mm.

HOW TO ADJUST

1. Use a 4 mm hexagonal wrench to loosen the clamping screw of the knife driving front arm.
2. Turn the rotary knife mounting base by hand so that the lubrication hole in the rotary knife mounting base is aligned with the marker dot engraved on the machine arm when the knife driving rear arm comes in light contact with the stopper. In this state, fix the rotary knife mounting base in place.

Position of the stopper plate

1. Loosen the stopper plate setscrew.
2. Move the stopper plate in the direction of the arrow and check for correct clearance between the stopper plate and the cam. Once correct clearance is obtained, fix the stopper plate in place by tightening the setscrew.

(Caution)

- o Use the lubrication hole and the marker dot engraved on the bed as reference points when positioning the rotary knife. After making the adjustment, be sure to check that the amount of engagement of the counter knife with the rotary knife is 1.0 to 1.5 mm.

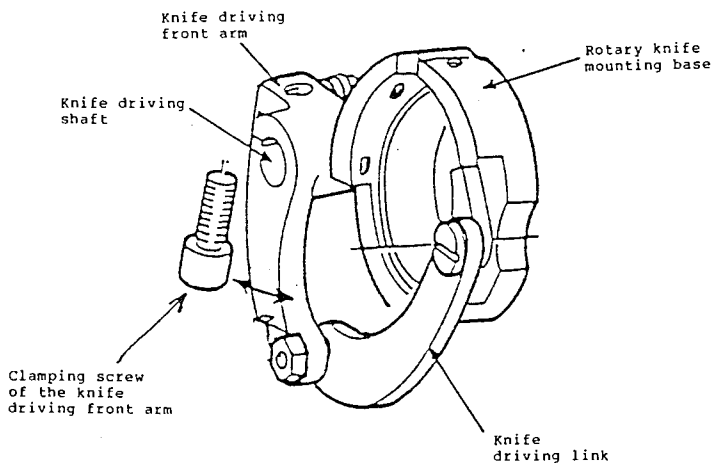

(Caution)

Be sure that there is no play with the knife driving shaft.

RESULTS OF IMPROPER ADJUSTMENT

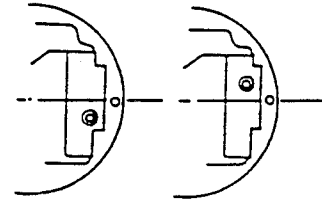

Before the marker dot engraved on the bed.

Beyond the marker dot engraved on the bed.

- If the rotary knife mounting base is positioned before the marker dot engraved on the bed:
 - o The length of the movement of the counter knife and rotary knife will be excessive. This will be good for sharply cutting thick thread, but the timing of the thread trimmer will be too early causing the thread remaining in the needle to become too short or the thread trimming knife to be actuated twice.
- o If the rotary knife mounting base is positioned beyond the marker dot engraved on the bed:
 - o The length of movement of the counter knife and rotary knife will be decreased causing the needle thread and bobbin thread to be poorly cut and a single yarn to remain.
 - o The timing of the thread trimmer will be delayed and the needle thread remaining in the needle will be shortened.
- Stopper plate
 - If there is no clearance between the stopper plate and the cam:
 - o Before the machine runs, the cam will come in contact with the cam roller and an abnormal operating noise may be produced.
 - If there is excessive clearance between the cam and the cam roller:
 - o The stroke of the rotary knife may be adequate causing the thread trimmer to be actuated twice.

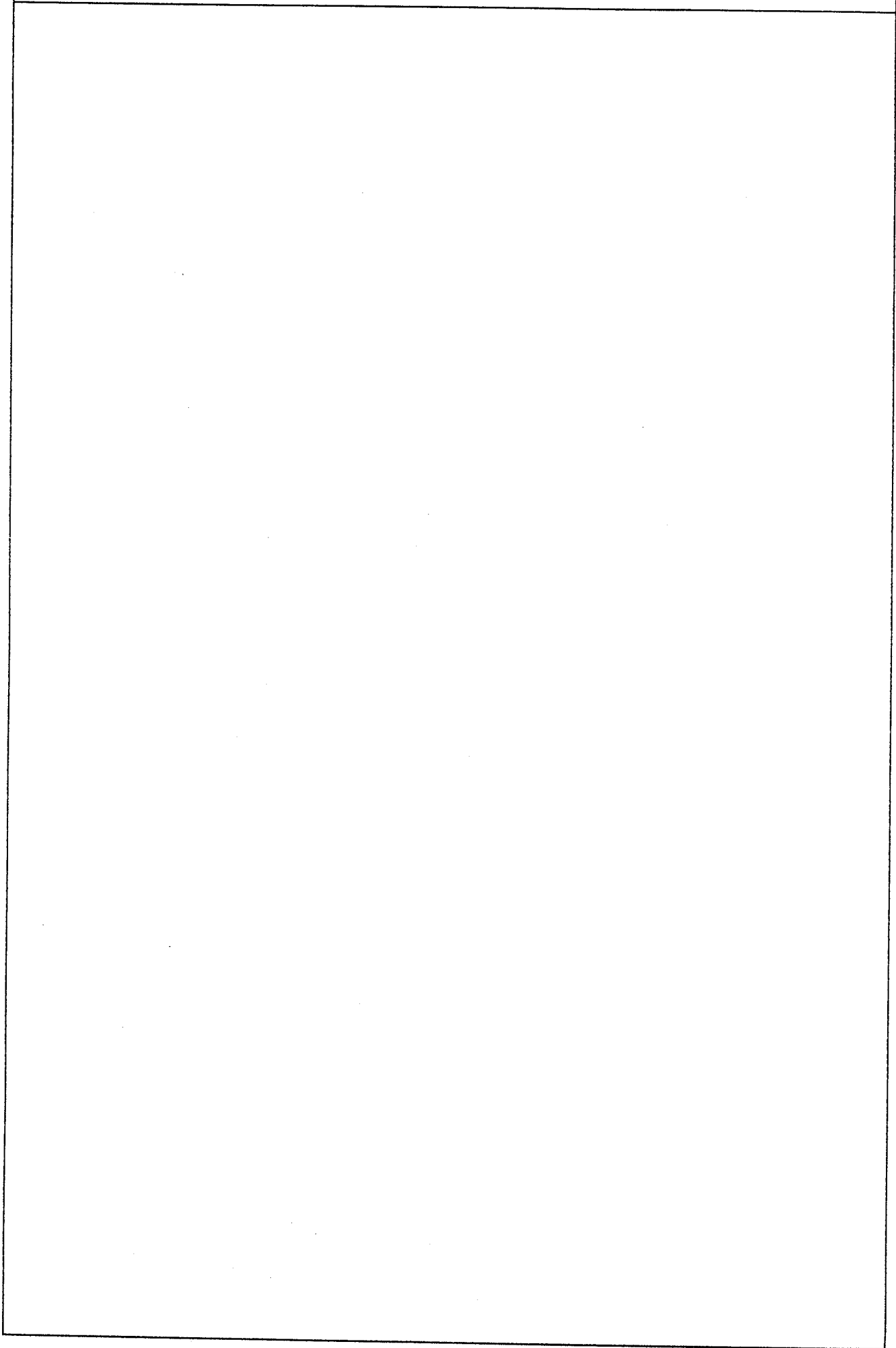

HOW TO ADJUST

RESULTS OF IMPROPER ADJUSTMENT

- Thread trimming point
When the counter knife blade comes in contact with the rotary knife blade, they are at an angle of 23 to 25° with respect to the highest dead point of the needle.
(The distance between marker dot A engraved on the handwheel and the marker dot engraved on the bed is equal to, or slightly greater than, the distance between marker dot B engraved on the handwheel and the dot engraved on the bed.)

Red marker dot engraved
on the handwheel

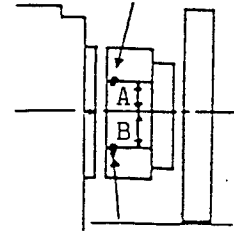

Marker dot engraved
on the handwheel



The blade sections
are aligned.

(c) Position of the needle thread retaining spring

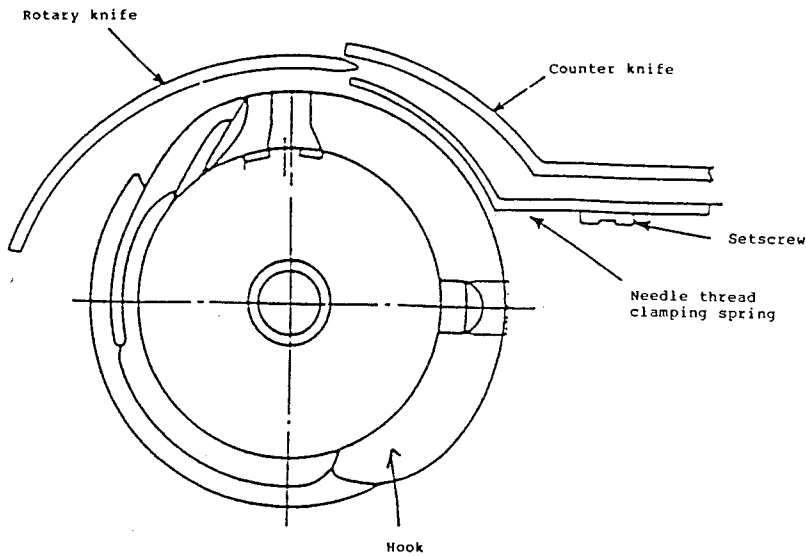

<Condition>

- o Fix the needle thread clamping spring so that it does not come in contact with the periphery of the hook and the rotary knife.

(d) Position of the thread trimming cam

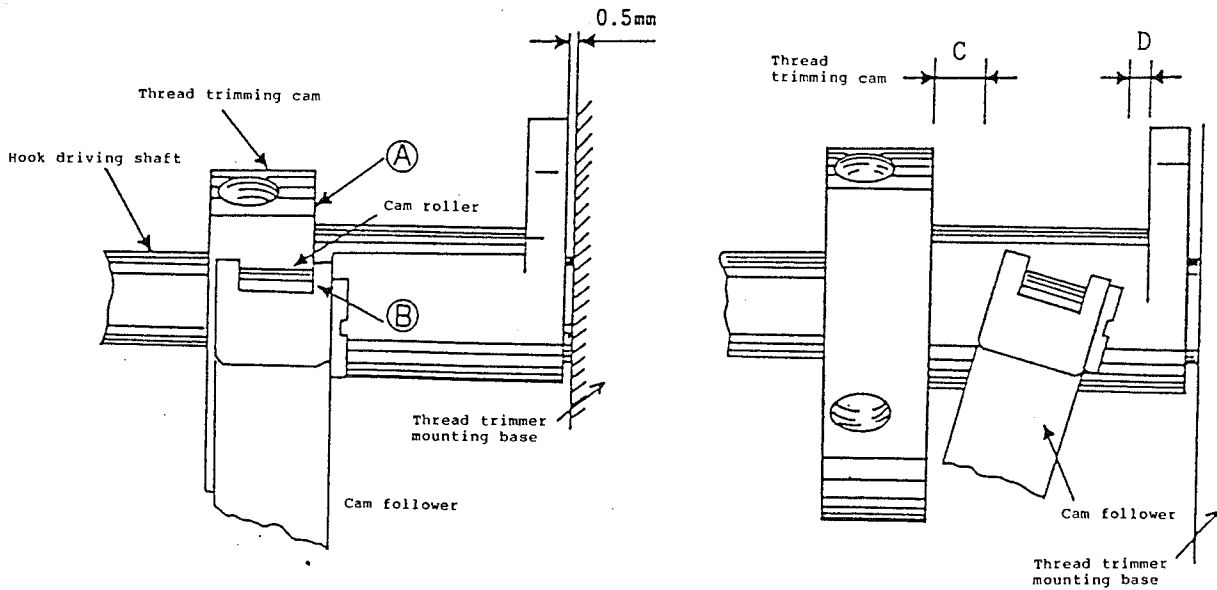

<Conditions>

- o The clearance between the thread trimmer mounting base and the thread trimming cam should be 0.5 mm (standard clearance).
- o Face A of the thread trimming cam engages with face B of the cam roller when the cam follower is positioned at right angles to the hook driving shaft.

<Condition>

- o When the cam follower is in its normal state, it should not come in contact with the thread trimming cam. (Clearances C and D should be obtained.)

HOW TO ADJUST	RESULTS OF IMPROPER ADJUSTMENT
<ol style="list-style-type: none"> 1. Loosen the needle thread clamping setscrew. 2. The needle thread clamping spring moves longitudinally up to 0.3 mm. 3. Fix the needle thread clamping spring in a position where it does not come in contact with the edge of the hook and rotary knife. 	<p>If there is excessive clearance between the needle thread clamping spring and the edge of the hook:</p> <ul style="list-style-type: none"> ● The rotary knife will go under the needle thread clamping spring <ul style="list-style-type: none"> ○ Neither the needle thread nor the bobbin thread will be trimmed. ○ The motor will lock. <p>If there is insufficient clearance between the needle thread clamping spring and the edge of the hook:</p> <ul style="list-style-type: none"> ○ The needle thread clamping spring may come in contact with the edge of the hook causing abnormal operating noise. ○ Irregular stitches (isolated idling loops) may be formed. ○ The hook may become scratched.

<ol style="list-style-type: none"> 1. Loosen the two setscrews of the thread trimming cam. 2. Move the thread trimming cam in the axial direction of the hook driving shaft and then fix the thread trimming cam in place. <p>(Caution)</p> <ul style="list-style-type: none"> ○ Since the timing of the thread trimmer can vary, be sure to check that the timing is correct after making the adjustment. ○ Be sure to firmly tighten the setscrews. 	<ul style="list-style-type: none"> ○ Abnormal operating noise. ○ An excessive load on the thread trimmer may result in faulty thread trimming or may cause the motor to lock.
--	---

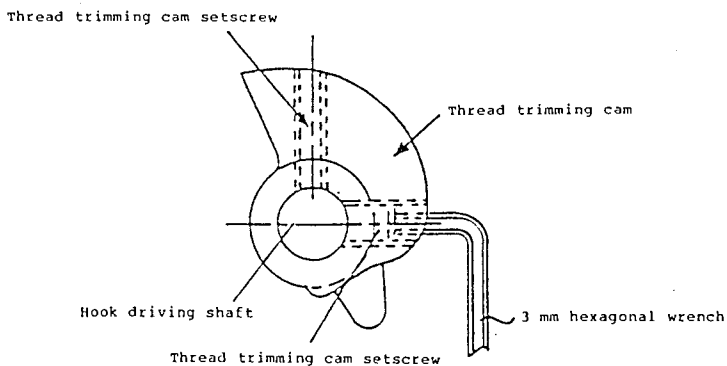

(e) Thread trimmer solenoid

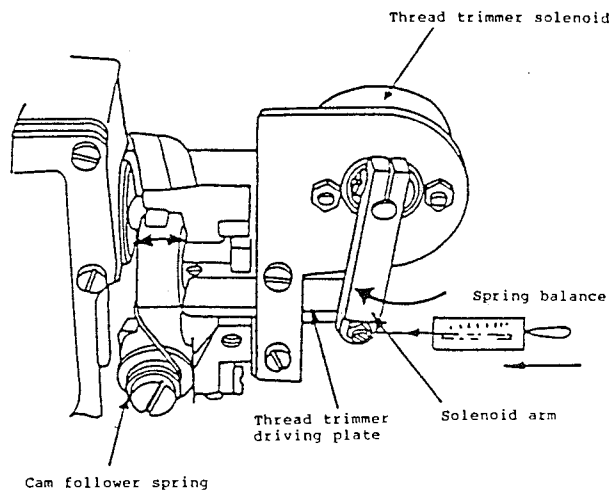
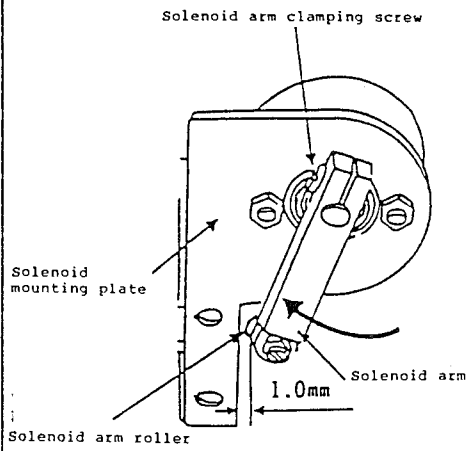

<Conditions>

- o Remove the solenoid mounting plate and turn the solenoid arm in the direction of the arrow until it will go no further. The clearance between the solenoid mounting plate and the solenoid arm roller should now be 1.0 mm.

<Condition>

- o The pressure of the solenoid arm spring should be 400 to 800 g.

HOW TO ADJUST	RESULTS OF IMPROPER ADJUSTMENT
<p>Position of the solenoid arm</p> <ol style="list-style-type: none"> 1. Loosen the solenoid arm clamping screw. 2. Turn the solenoid arm to adjust its position, and then tighten the solenoid arm clamping screw. 	<p>Position of the solenoid arm</p> <p>If the clearance between the solenoid mounting plate and the solenoid arm roller is excessive (1 mm or more):</p> <ul style="list-style-type: none"> o The solenoid stroke will be inadequate, and the thread trimmer components will not be actuated. <p>If there is no clearance between the solenoid mounting plate and the solenoid arm roller:</p> <ul style="list-style-type: none"> o The thread trimmer driving plate will be unable to return to the specified position. The knife may become broken and abnormal operating noise may be produced. <p>Cam follower spring</p> <p>If the spring pressure is too great:</p> <ul style="list-style-type: none"> o If the spring pressure is greater than the suction force of the thread trimming solenoid, the thread trimmer components may fail to work. <p>If the spring pressure is insufficient:</p> <ul style="list-style-type: none"> o The cam follower may fail to return to the starting position and the needle may come in contact with the rotary knife. As a result, the blade of the knife and the needle may become broken.

(f) Pressure of the counter knife

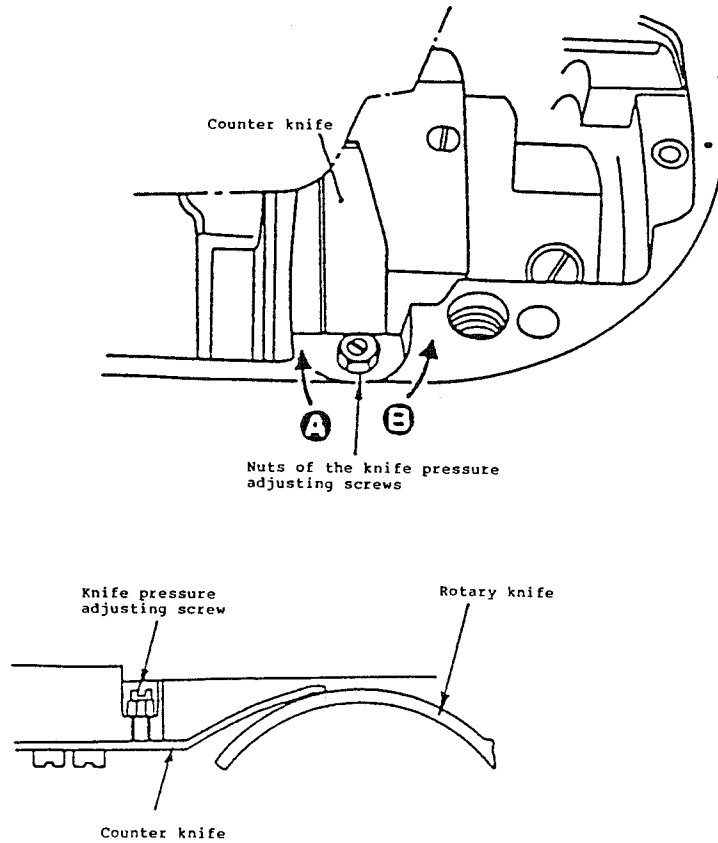

2) Automatic reverse feed device

(1) Plunger stroke

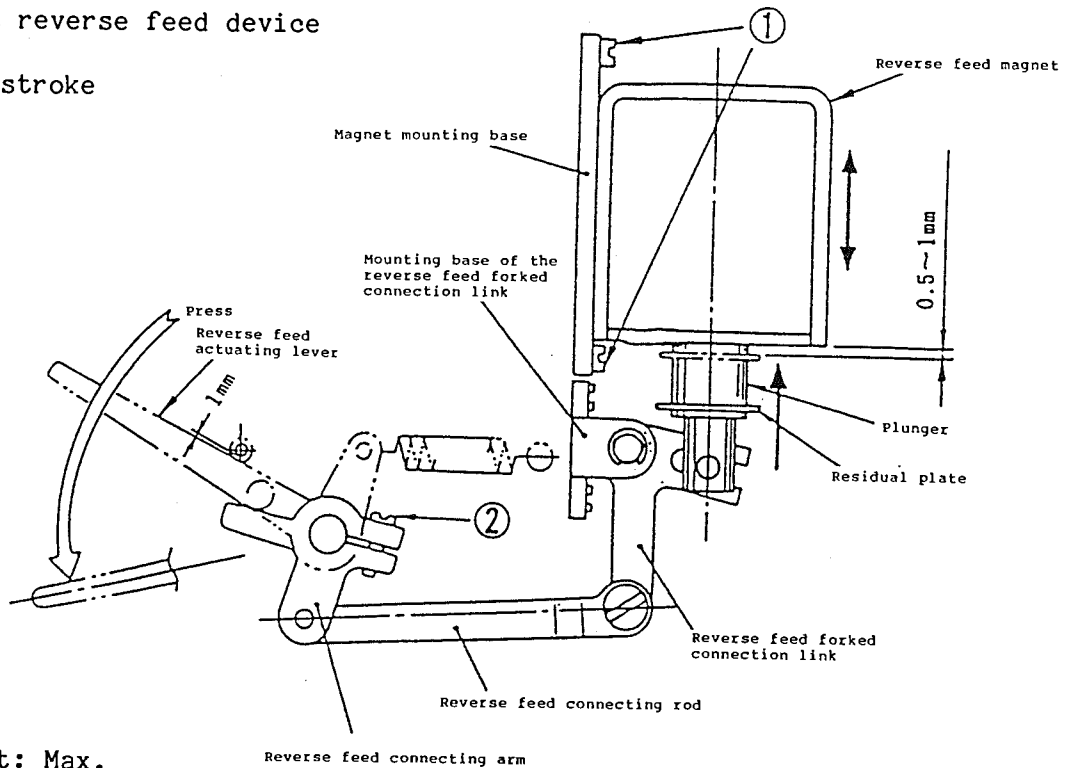

<Conditions>

- o Feed amount: Max.
- o The clearance between the reverse feed magnet and the plunger residual plate is 0.5 to 1 mm when the reverse feed lever is pressed until it will go no further.

HOW TO ADJUST	RESULTS OF IMPROPER ADJUSTMENT
<ol style="list-style-type: none"> 1. Use a 5 mm spanner to loosen the knife pressure regulating screw. 2. Turn the knife pressure adjusting screw and adjust the pressure applied to the knife. 3. Turning the regulating screw clockwise will increase the pressure. (Turn the screw 30° at a time.) 4. Tighten the nut on the knife pressure regulating screw after the appropriate pressure to be applied to the knife has been obtained. <p>(Caution) If the nut is excessively tightened, the screw may become damaged.</p>	<p>The pressure applied to the knife is insufficient.</p> <ul style="list-style-type: none"> o Both the needle thread and the bobbin thread may not be trimmed. <p>The pressure applied to the knife is excessive.</p> <ul style="list-style-type: none"> o The machine is likely to lock. ● It is advisable to use the machine with minimal pressure applied to the knife, provided that the needle thread and bobbin thread are cut successfully.
<ol style="list-style-type: none"> 1. Set the feed regulating dial to its maximum value. 2. Loosen setscrew ① of the magnet mounting base. 3. Press the reverse feed lever until it will go no further, move the magnet mounting base up and down, and adjust so that the clearance between the residual plate attached to the plunger and the inner surface of the reverse feed magnet is 0.5 to 1 mm. Then tighten the setscrew. 	<p>If the clearance between the residual plate and the inner surface of the reverse feed magnet is excessive:</p> <ul style="list-style-type: none"> o The suction force of the magnet will be decreased and the reverse feed mechanism may fail to be actuated. <p>If the clearance is insufficient:</p> <ul style="list-style-type: none"> o The stitch length during reverse feed stitching may be smaller than during normal feed stitching.

(To assemble the thread trimmer components, follow the procedure for disassembling the thread components in the reverse order.)

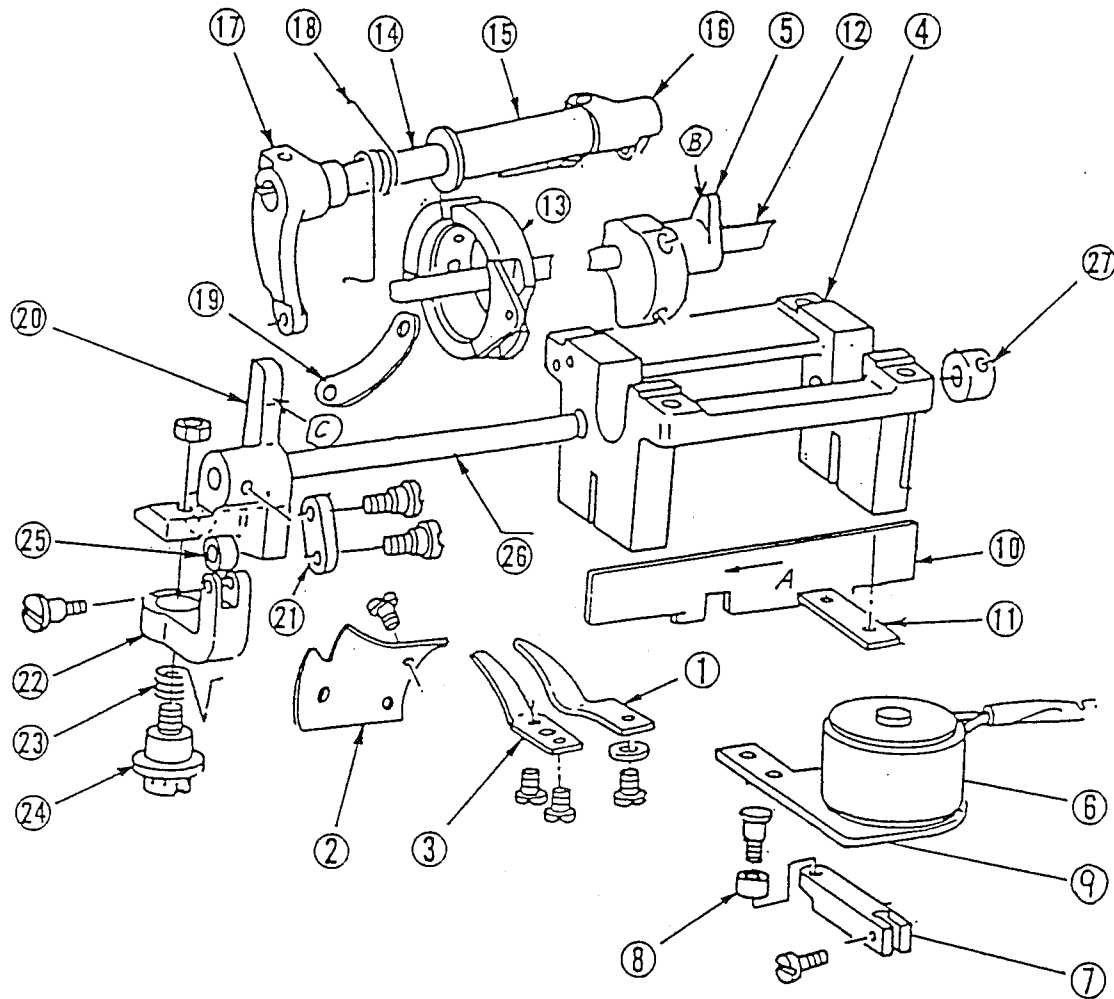

Main components of the thread trimmer

- | | |
|---|--|
| ① Needle thread clamping spring | ⑭ Knife driving shaft |
| ② Rotary knife | ⑮ Bushing of the knife driving shaft |
| ③ Counter knife | ⑯ Rear arm of the knife driving shaft |
| ④ Thread trimmer mounting base | ⑰ Front arm of the knife driving shaft |
| ⑤ Thread trimmer cam | ⑱ Knife returning spring |
| ⑥ Thread trimmer solenoid | ⑲ Knife driving link |
| ⑦ Arm of the thread trimmer solenoid | ⑳ Cam driving base |
| ⑧ Arm roller of the thread trimmer solenoid | ㉑ Cam driving link |
| ⑨ Mounting plate of the thread trimmer solenoid | ㉒ Cam follower |
| ⑩ Thread trimmer driving plate | ㉓ Cam follower returning spring |
| ⑪ Presser plate of the thread trimmer driving plate | ㉔ Cam follower shaft |
| ⑫ Hook driving shaft | ㉕ Cam follower roller |
| ⑬ Rotary knife base | ㉖ Cam driving shaft |
| | ㉗ Thrust collar of the cam driving shaft |

ASSEMBLY/DISASSEMBLY	ITEMS TO BE CHECKED
<ol style="list-style-type: none"> 1. Remove rotary knife ② and counter knife ③. 2. Remove the hinge screw of knife driving link ⑱. 3. Remove knife returning spring ⑱ hanging from knife driving front arm ⑰. 4. Loosen the clamping screw of knife driving rear arm ⑯, and pull the knife driving front arm to remove knife driving shaft ⑭. 5. Loosen the setscrew of presser plate ⑪ of the thread trimmer driving plate and the setscrew of mounting plate ⑨ of the thread trimmer solenoid to remove the thread trimmer driving plate and the mounting plate of the thread trimmer solenoid. Then remove the thread trimmer driving plate ⑩. 6. Loosen the four setscrews of thread trimmer mounting base ④, and remove thread trimmer mounting base ④ and components ⑯, ⑳ through ㉓ assembled as they are. 7. Remove thrust collar ㉓ of the cam driving shaft, and pull the cam driving base ㉒ to remove cam driving shaft ㉒. 8. Remove cam follower returning spring ㉓ from the spring hook hole of cam follower shaft ㉔, loosen the lock nut of cam follower shaft ㉔, and remove the cam follower shaft. 9. Remove the setscrews and hinge screws of each component. (No particular order is necessary.) 	<ol style="list-style-type: none"> 1. Be sure to loosen the counter knife pressure adjusting screw. 2. Be sure that there is no play in the knife driving shaft when assembling. 3. When assembling, the smooth movement of the thread trimmer components will be hindered if the axial position of the thread trimmer mounting base is not appropriate. 4. Be sure that there is no play in the cam driving shaft when assembling. 5. Be sure that there is no play in the cam follower. 6. Be sure that thread trimmer solenoid roller ⑧ and cam follower roller ㉓ rotate smoothly.

EXPLANATION

1. When thread trimmer solenoid ⑥ is turned on, thread trimmer driving plate ⑩ will move in direction A.
2. Along with the movement of the thread trimmer driving plate, cam follower ㉒ will move at right angles with hook driving shaft ⑫.
3. The rotation of thread trimmer cam ⑤ causes the surface of the cam to engage with cam follower roller ㉓. As a result, the cam follower is pushed up.
4. Cam driving base ㉒, which is integrated with the cam follower, also rotates (oscillation).
5. The cam driving base and rear arm ⑯ of the knife driving shaft are connected with cam driving link ㉑, causing knife driving shaft ⑭ to oscillate. Rotary knife ② catches both the needle and bottom threads, cutting them while actuating counter knife ③.
6. The oscillation of the knife driving shaft is propagated to rotary knife mounting base ⑬ through fork section ⑰ of the knife driving shaft and knife driving link ⑱.
7. The cam follower is now no longer engaged with the thread trimmer cam, section ⑧ of the thread trimmer cam comes in contact with section ③ of the knife driving base, and the rotary knife base moves back toward its starting position by approximately one third of the whole distance.
8. Knife returning spring ⑱ returns the rotary knife base to its starting position. At the same time, the power to the thread trimmer solenoid is turned off, and cam follower spring ㉓ returns components ⑩ and ㉒ to

5. MOTOR

1) Synchronizer

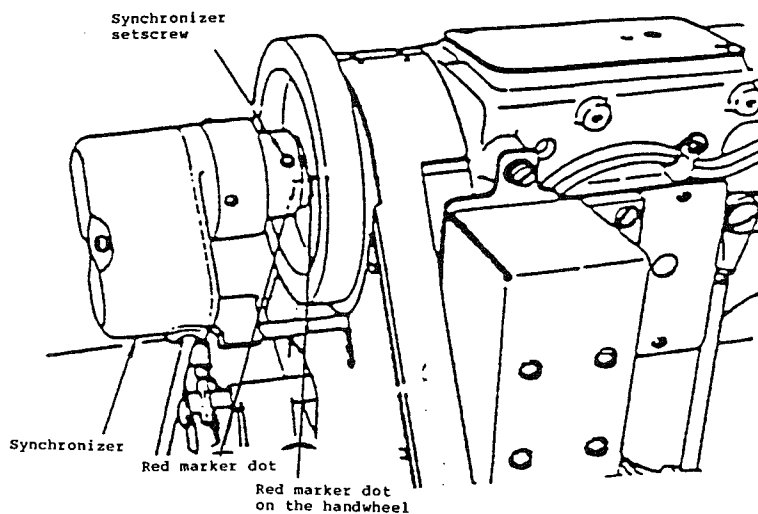

<Conditions>

- o The red marker dot on the machine arm is aligned with the red marker dot on the handwheel (when the machine stops with the needle up).
- o The red marker dot on the synchronizer is aligned with the red marker dot on the boss of the handwheel. (Use these marker dots as reference points.)

2) Machine start, end back, and soft start

Adjust these functions in accordance with the type of garment to be sewn, the sewing process and other sewing specifications.

HOW TO ADJUST

1. Pull out the thread trimmer signal cable.
2. Be sure that the machine stops with the needle up (to place the material in the sewing position and to thread the needle).
3. Loosen the two screws in the synchronizer rotor, and finely adjust so that the red marker dot on the machine arm is aligned with the red marker dot on the handwheel.
4. Connect the thread trimmer signal cable and re-check that the machine stops with the needle up.

RESULTS OF IMPROPER ADJUSTMENT

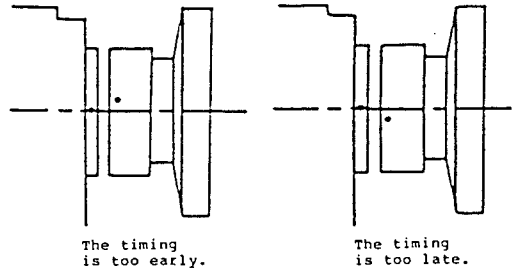

If the timing of synchronizer actuation is too early:

- o Thread trimming may be faulty.
- o The cam roller is unable to disengage from the thread trimmer cam. The machine makes a clanging noise at the start of sewing.
- o If the timing is excessively early, the knife may become broken.

If the timing of synchronizer actuation is too late:

- o Thread trimming may be faulty.
- o The position of the needle bar will be lower than normal when the machine stops.

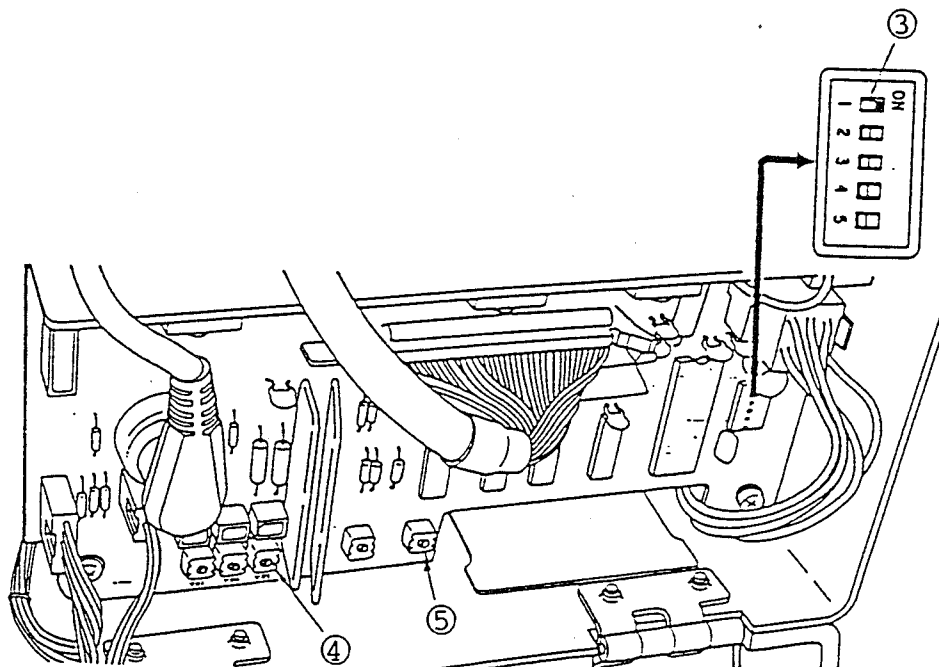

- 3) Selecting the soft start function
 Press section (P) and remove cover (1) from the CPU panel. You will then be able to see DIP switches (2) from No. 1 to No. 8. Set DIP switch No. 6 to its ON position.

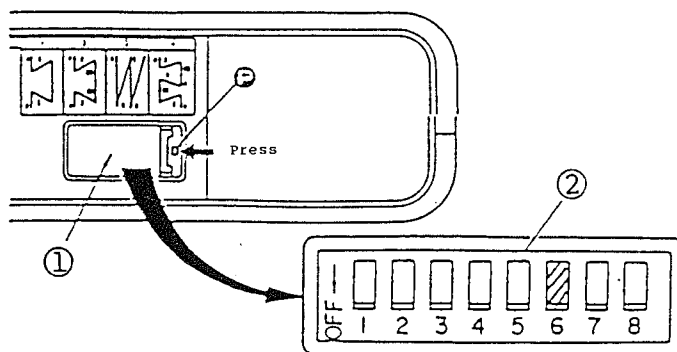

- 4) Sewing speed for reverse stitching
 The sewing speed for reverse stitching is adjusted by means of dial knob (5) in the PSC box. Turning the dial knob clockwise will increase the sewing speed, while turning the dial knob counterclockwise will decrease it.
 It is better to set the sewing speed for reverse stitching so that it is as low as possible (approx. 1,500 s.p.m.).

(Caution)

Turn OFF the CPU panel display, and set DIP switch (3) in the PSC box to its ON position.

- No. 2 ... Thread trimming speed
- No. 3 ... Soft start speed
- No. 4 ... Reverse stitching speed (low speed)
- No. 5 ... Reverse stitching speed (high speed)

- 5) Thread trimming speed
 The thread trimming speed is adjusted using dial knob 4 in the PSC box. Turning the dial knob clockwise will increase the thread trimming speed, while turning the dial knob counterclockwise will decrease it.
 The standard speed is 185 s.p.m.

o When using a thin thread, set the thread trimming speed to between 160 and 185 s.p.m.

When using a thick thread, set it to between 185 and 200 s.p.m.

HOW TO ADJUST	RESULTS OF IMPROPER ADJUSTMENT

Part name	Part No.	Remarks
Rotary knife	D2423241E00	
Counter knife	D2424241E00	
Needle thread clamping spring	D2429241E00	
Hook (asm.)	D1830241EA0	
Bobbin (aluminum)	D9117141E00	
Bobbin case (asm.)	D1837141EA0	Including an idling prevention spring
Idling prevention spring A	D1838141E00	

7. PARTS TO BE APPLIED WITH LOCK-TITE PAINT

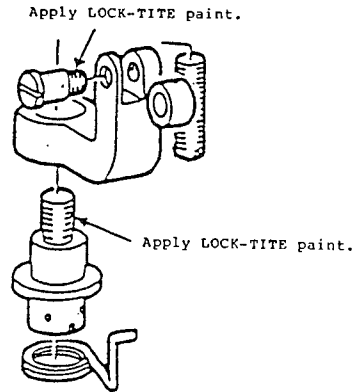
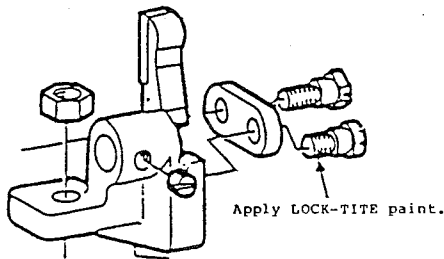

8. OPTIONAL PARTS

(Refer to the catalog for the gauge sets.)

For thin thread

Part name	Part No.
Feed dog	D1613241EOA
Idling prevention spring B	D1838141EOA
Walking foot	D1470241E00
Walking foot (split type)	D1470241EOA

For heavy-weight material

Feed dog (with groove)	D1613241EOB
------------------------	-------------

9. TROUBLESHOOTING (Mechanical parts)

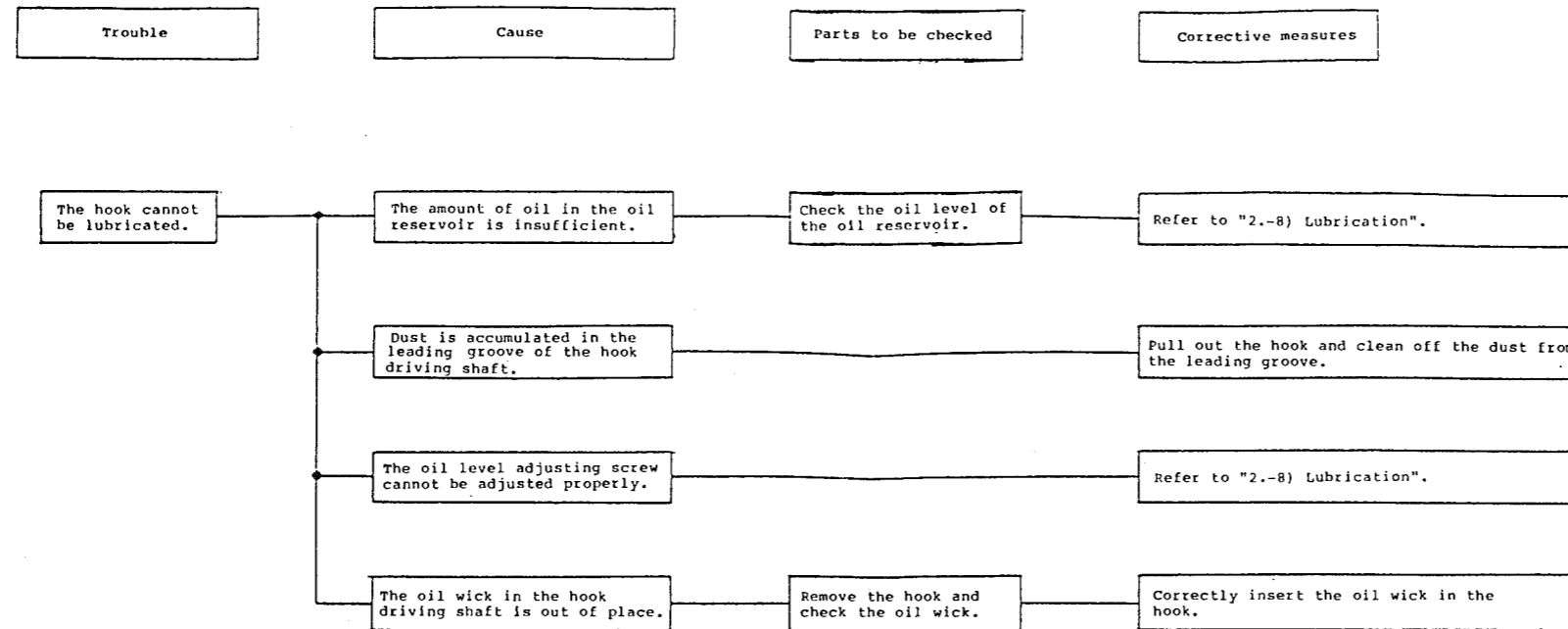

10. TROUBLESHOOTING (Sewing condition)

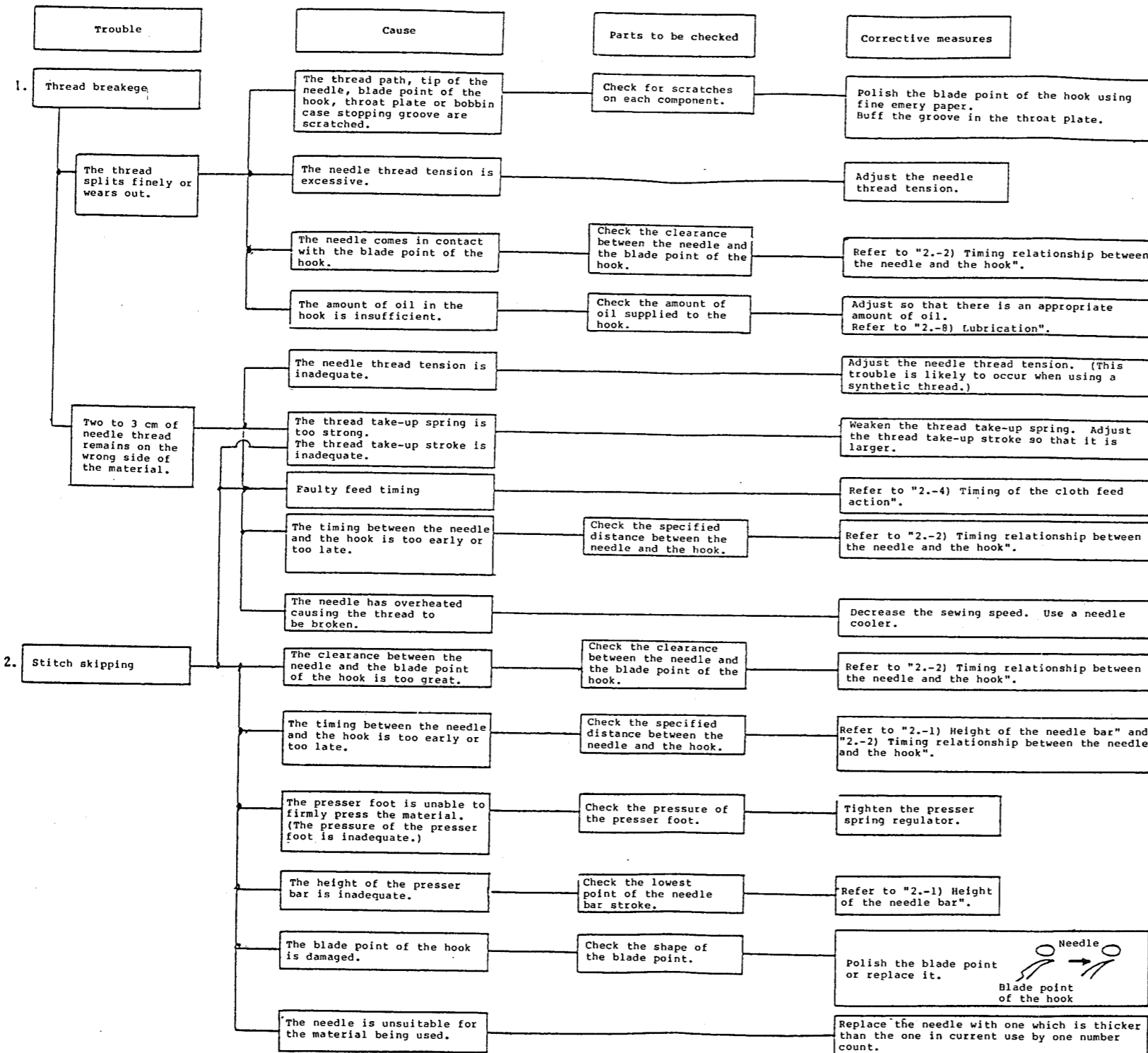

Test report

• If there is frequent stitch skipping when using a synthetic thread (Tetron #30 - #40):
1) The frequency of stitch skipping will be reduced by winding the thread around the needle.

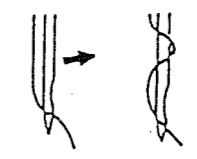

• Decreasing the lift amount of the walking foot will be effective in preventing thread breakage.

10. TROUBLESHOOTING (Sewing condition)

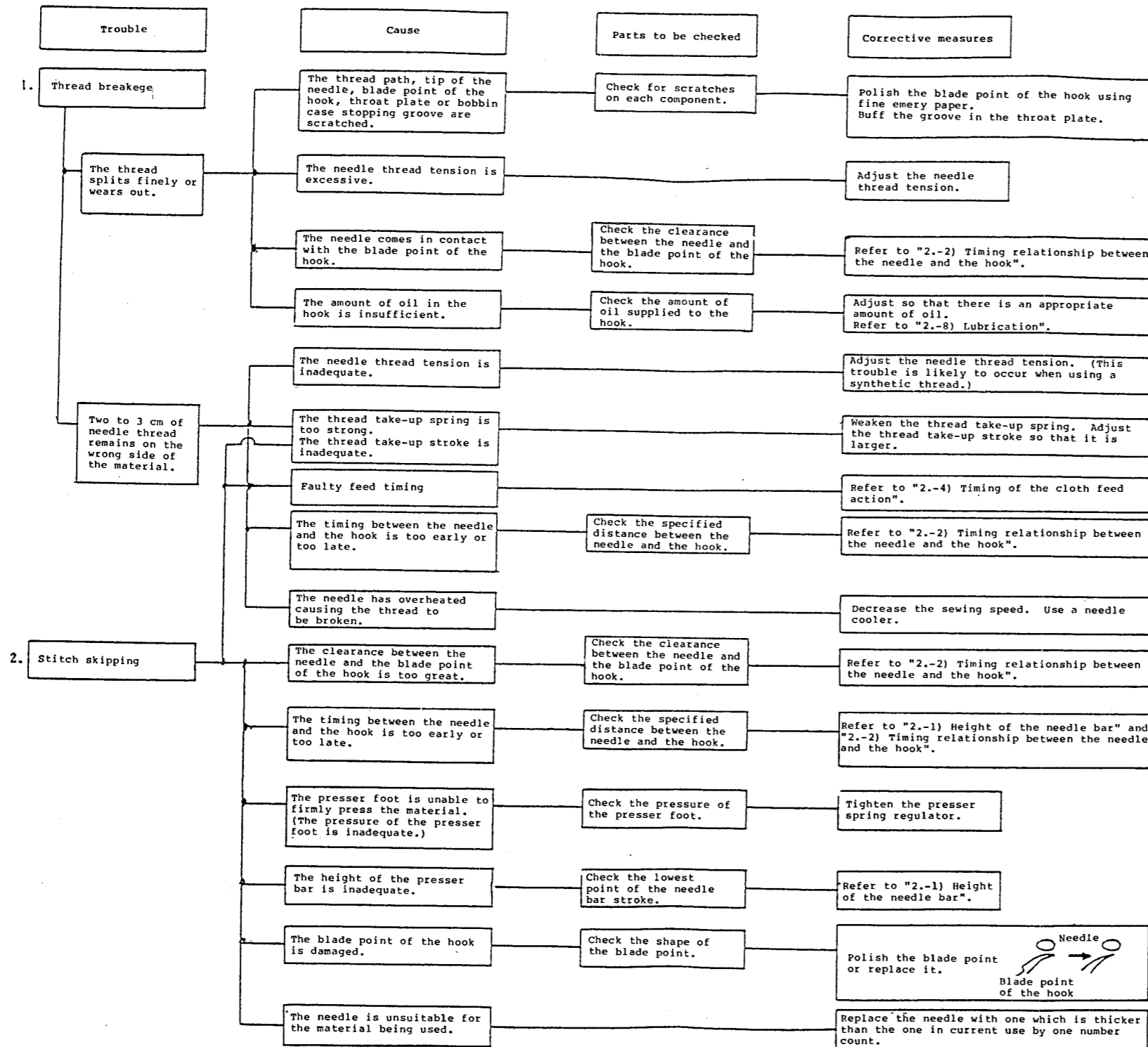

Test report

- If there is frequent stitch skipping when using a synthetic thread (Tetron #30 - #40):
 - 1) The frequency of stitch skipping will be reduced by winding the thread around the needle.

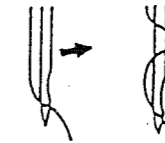

- Decreasing the lift amount of the walking foot will be effective in preventing thread breakage.

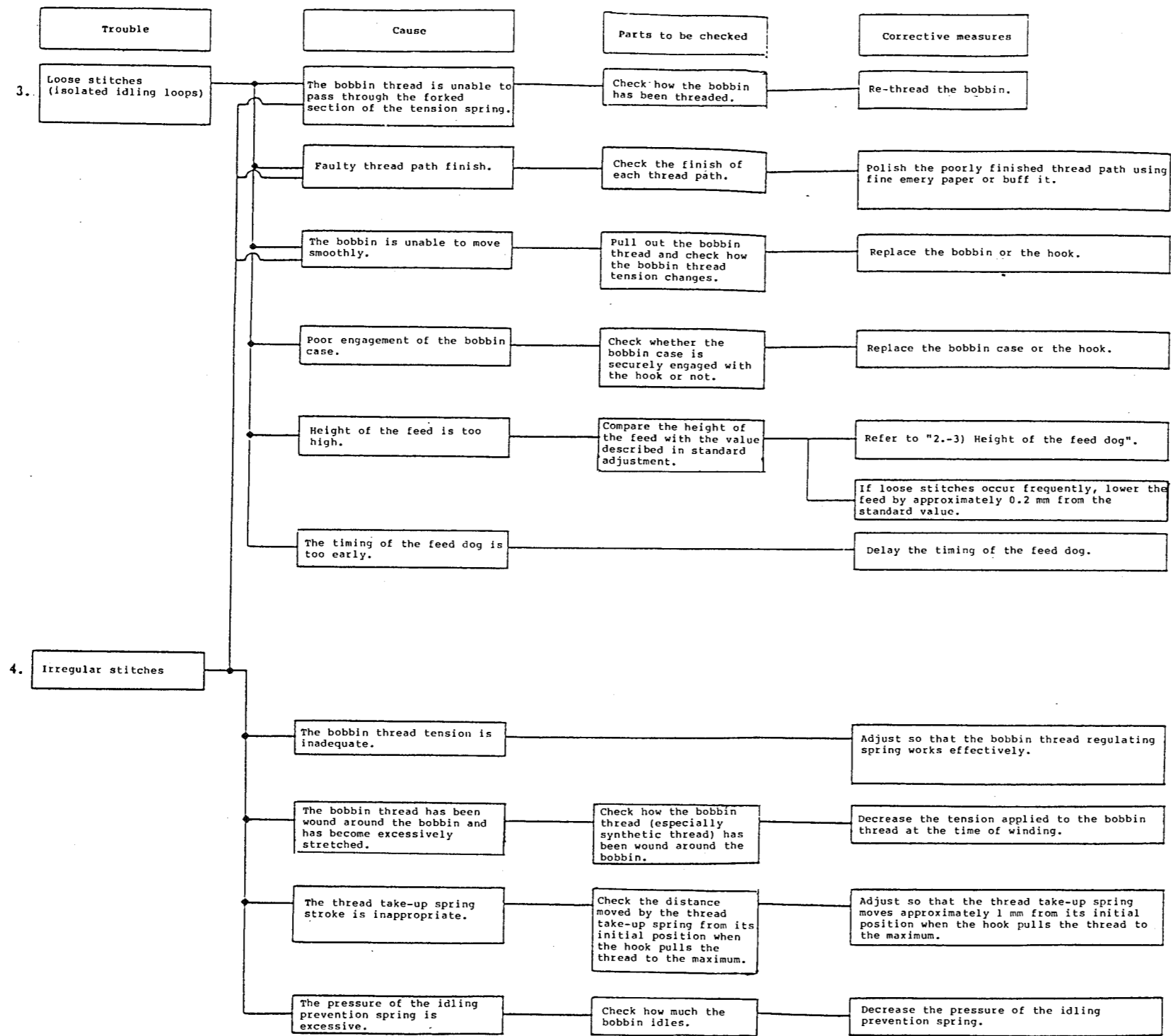

• Irregular stitches can be prevented if the pressure and stroke of the thread take-up spring has been set to their lowest values.

11. TROUBLESHOOTING FOR THE ADDITIONAL DEVICES

Trouble	Cause	Parts to be checked	Corrective measures
Automatic thread trimming			
1. Immediately after the thread has been trimmed, the needle thread slips off the needle eyelet.	Thread tension No. 1 has been adjusted so that it has become excessively strong.	Check thread tension No. 1.	Decrease the tension of thread tension No. 1.
	The thread trimmer is actuated too early.	Check the position of the cam with regard to the marker dot engraved on the handwheel.	Refer to "3.-1)-(a) Timing of the thread trimmer".
	The thread tension disk is unable to float properly.	Check how high the thread tension disk floats.	Increase the floating amount of the disk.
	The thread slips off the needle eyelet as a result of the return movement of the thread take-up spring after the thread trimming knife has dropped and cut the thread.	Check whether the thread being used is a thin type of thread (including tetron or nylon thread).	If the above type of thread is being used, replace the thread guide with the thread guide supplied with the unit.
	The needle thread is trimmed twice (double-cutting).	Approximately 30 mm of thread may be wound around the hook.	Refer to "3.-1)-(a) Timing of the thread trimmer".
2. The needle thread slips off the needle eyelet at the sewing start.	The remaining needle thread is too short.		
	Thread tension No. 1 has been adjusted so that it has become excessively strong.	Check thread tension No. 1.	Decrease the tension of thread tension No. 1.
	The thread tension disk is unable to float properly.	Check how high the thread tension disk floats.	Increase the floating amount of the disk.
	The thread trimmer is actuated too early.	Check the position of the cam with regard to the marker dot engraved on the handwheel.	Refer to "3.-1)-(a) Timing of the thread trimmer".
	The thread slips off the needle eyelet as a result of the return movement of the thread take-up spring after the thread trimming knife has dropped and cut the thread.	Check whether the thread being used is a thin type of thread (including tetron or nylon thread).	If the above type of thread is being used, replace the thread guide with the thread guide supplied with the unit.
3. A seam cannot be formed after several stitches have been sewn at the sewing start.	The bobbin thread tension is inadequate.		Increase the bobbin thread tension.
	The machine stops before the needle bar reaches its highest position.	Check whether the travelling distance of the thread take-up from its position at the time when sewing stops to the highest position of its stroke is too long.	Refer to "5.-1) Synchronizer".
	The bobbin idles too much.	Check the thread trimming speed. Check that an aluminum bobbin is being used.	Decrease the thread trimming speed. Use an aluminum bobbin.
	The bobbin thread has been torn off.	Check the amount of bobbin thread remaining on the bobbin.	Use the feed for thin thread. Refer to "8. Optional parts".
	The bobbin thread is too short.		

• If you have much trouble with "the needle thread slips from the needle eyelet" or "a seam cannot be formed after several stitches," in most cases the remaining needle thread is too short. These troubles frequently occur when a thin synthetic thread is used and when the stitch length is set to a smaller value. Be sure to delay the timing of the thread trimmer so that the thread take-up amount is decreased.

HOW TO ADJUST

- Turn the handwheel by distance A. (Distance A ranges from 0 to 5 mm).
- Adjust the cam while following the steps described in "3.-1)-(a) Timing of the thread trimmer".
- Delay the timing of synchronizer actuation by the same amount of timing set for the thread trimmer.

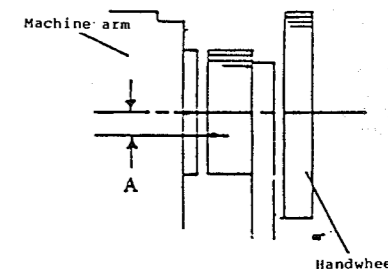

(Caution)
Decrease distance A so that it is as small as possible, provided that approximately 30 mm of needle thread remain.

• If you have much trouble with "a seam cannot be formed after several stitches":
This trouble may occur when a thin synthetic thread is being used and the amount of remaining bobbin thread is insufficient.
In such a case, wind spare thread around the bobbin before winding the thin thread to be used for sewing.

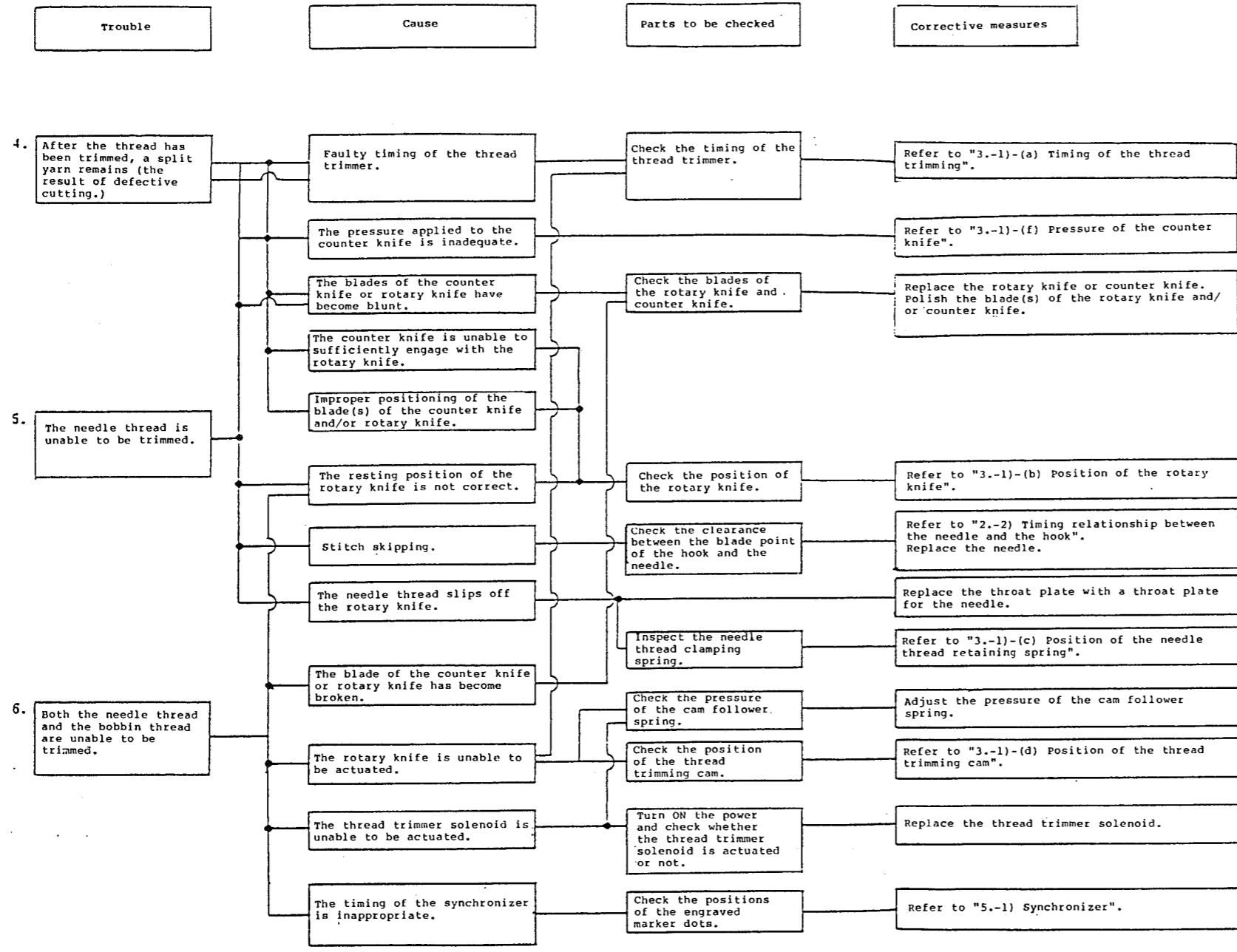

Test report

- How to grind the knife blades
- o Counter knife

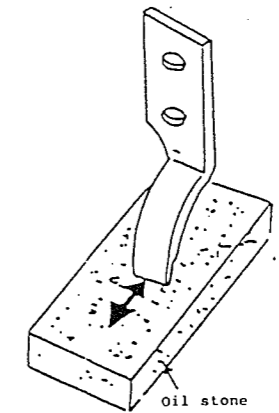

Press the blade onto the oil stone with an appropriate degree of strength, and grind the blade.

o Rotary knife

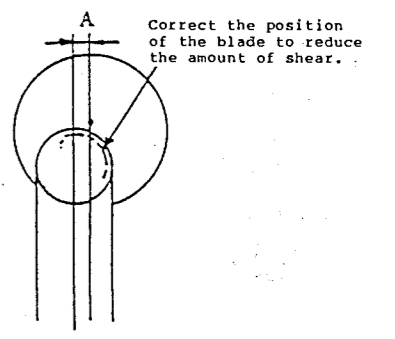
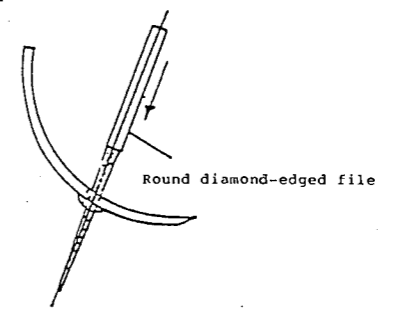

If the protruding section of the knife cannot be aligned with the blade point (distance A, or if the blade wears out, be sure to correct the position of the blade point, or grind the blunt blade.

- When using a non-twisted thread, the needle thread may not be cut after the knife has dropped for the purpose of cutting the needle thread. In this case, replace the needle with a ball-point needle (one whose tip is not very sharp).

