

JUKI®
MOR-800 Series

**Variable Top Feed Overedger & Safety
Stitcher (Rake-in type)**
ENGINEER'S MANUAL

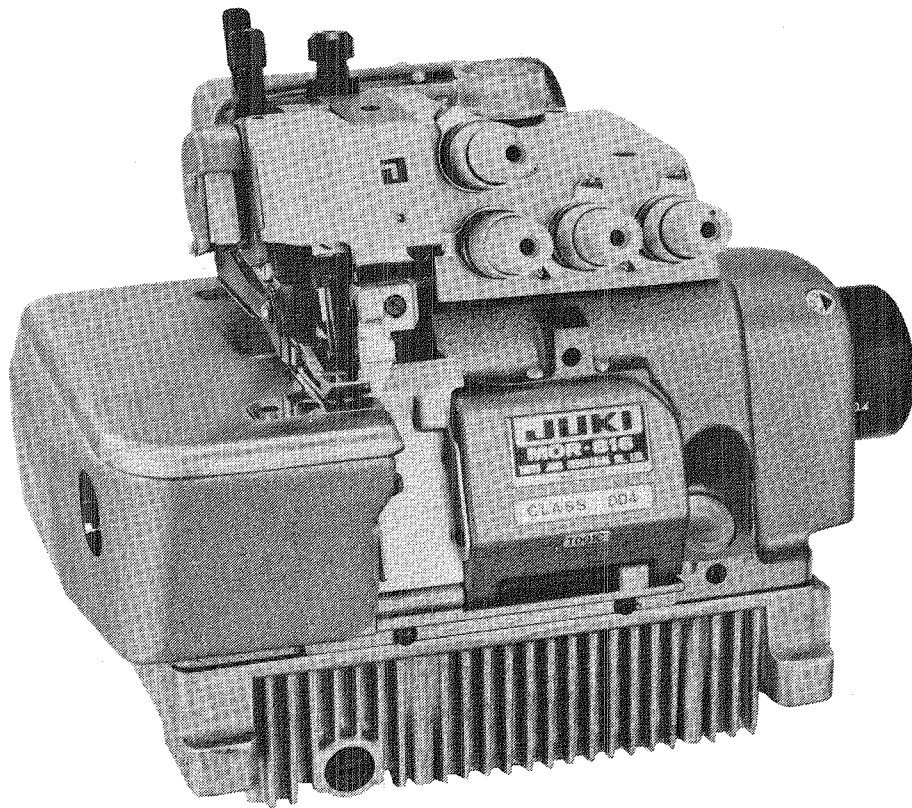

TOKYO JUKI INDUSTRIAL CO., LTD.

Introduction

This Engineer's manual is directed to service engineers.

Although detailed explanations are given in the Instruction Book directed to those who maintain or operate sewing machines at a sewing factory, this manual specifically supplies information such as "how to adjust", "phenomena caused by the changes in adjustment standard" and the function of each device.

Since MOR-800 series machine is a variety of MO-800 series characterized by an addition of top feed mechanism, here we limit the explanations to what is different from MO-800 series (those concerning top feed); so please refer to the engineer's manual of MO-800 for the items that are not mentioned in this manual.

It is advisable to use also the Instruction Book and the Parts Book as well for maintenance work.

CONTENTS

1. OUTLINE	1
2. SPECIFICATIONS	1
3. OPERATIONAL CAUTIONS	2
(1) Setting of the presser foot	2
(2) Top feed amount	2
4. ADJUSTMENT STANDARD	3
(1) Adjustment of top differential feed ratio	3
(2) Pressure of the top feed dog	5
(3) Timing of the looper thread cam	5
5. ADJUSTMENT OF TOP FEED MECHANISM	7
(1) Horizontal motion	7
1) How to replace the top feed bar rubber cushion	7
(2) Vertical motion	9
1) How to replace the collar	9
(3) How to replace the variable top feed plate	10
(4) Presser foot to needle relation	10
(5) Position of the variable top feed holder	11
(6) Position of the top feed dog	11
6. OTHER THINGS TO BE NOTED	12
(1) Table	12
(2) Replacement of top feed link cover	12
7. TROUBLES AND CORRECTIVE MEASURES	13
(1) Fabrics are scratched by the top feed dog	13
(2) Fabrics become shiny (marked by the top feed dog)	13
(3) Other troubles	13

1. Outline

The MOR-800 series machine is developed from MO-800 series by adding a top feed mechanism and useful for sewing light to heavy weight fabrics which require a device for preventing irregular stitches and those which require high feeding power to keep a steady feed where fabrics are overlapped.

○ Main Advantages

1. This machine permits even an inexperienced operator to sew difficult-to-feed materials without an irregular stitch and ensures products of high-quality.
2. Smooth and steady feeding of fabrics makes the operation easy.
3. High feeding power in the section where fabrics are jointed ensures smooth stitching and products of high-quality.
4. Swing type top feed dog makes threading work and needle replacement work easier and quicker.
5. Top differential feed ratio can be easily adjusted with an externally installed dial.

○ Applications

1. Piping, side seam on the legs of track pants.
2. Joining of knitwear.
3. Runstitching the extremely stretching materials.
4. Process to be secured from puckering by irregular stitches.
5. Other processes in which irregular stitches tend to occur.

○ Caution

Use MO-800 series machine for light-weight materials difficult to feed because of the friction against presser foot.

2. Specifications

1. Model	MOR-816	MOR-814S
2. Feed system	differential top and bottom feed (rake-in type)	
3. Sewing speed (max.)	4,000 s.p.m.	4,000 s.p.m.
4. Top differential feed ratio	standard : 1:0.75 ~ 1:1.3 (main feed dog: top feed dog) maximum : 1:1 ~ 1:2 (main feed dog: top feed dog) (provided that the stitch length doesn't exceed 3.0 mm (1/8") when the ratio is 1:2)	
5. Top feed dog lift	6.5 mm (1/4") (6 mm with MOR-814SBD7/606)	
6. Presser foot lift	5.5 mm (7/32") (5mm with MOR-814SBD7/606)	

3. Operational Cautions

(1) Setting of the presser foot

Before operating the machine, be sure that variable top feed holder ① is inserted in pin ②.
(You can easily replace or remove the presser foot by turning the pulley so that the letter "L" comes at the top.)

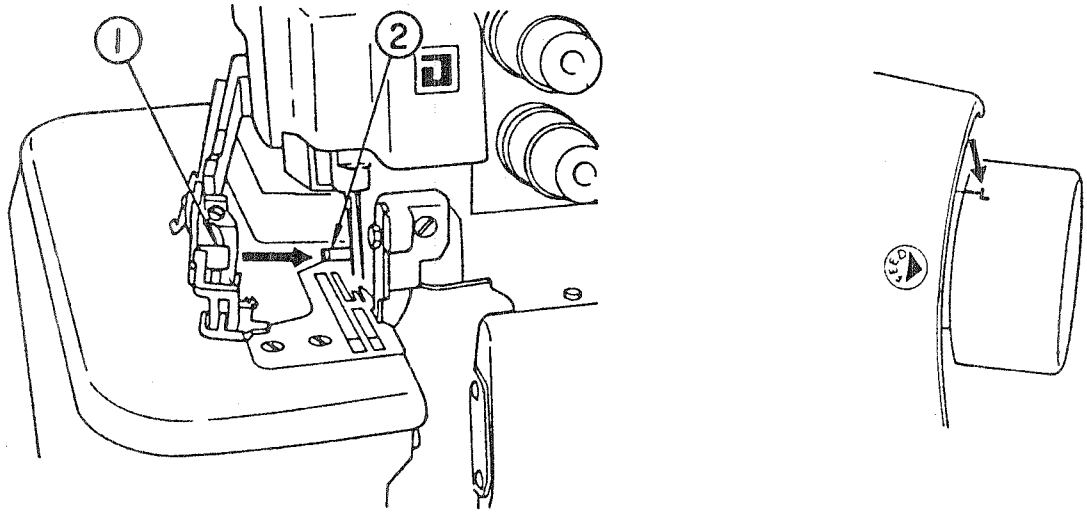

(2) Top feed amount

The maximum top feed amount is 6 mm.

If you use the machine with a stitch length of 4 mm, adjust the top differential feed ratio to less than 1:1.5.

4. Adjustment Standard

Adjustment Standard

(1) Adjustment of top differential feed ratio

Standard ratio 1:0.75 ~ 1:1.3 (main feed dog: top feed dog)	Maximum ratio 1:1 ~ 1:2 (main feed dog: top feed dog) (provided that the stitch length doesn't exceed 3.0 mm)
1:1 ratio adjustment The pin ④ comes between the 3rd and the 4th lines from the bottom engraved on the bushing ⑤.	1:1 ratio adjustment The pin ④ meets the bottom line engraved on the bushing ⑤.
1:0.75 ratio adjustment The pin ④ meets the bottom engraved line.	1:2 ratio adjustment The pin ④ meets the top engraved line.
1:1.3 ratio adjustment The pin ④ meets the top engraved line.	

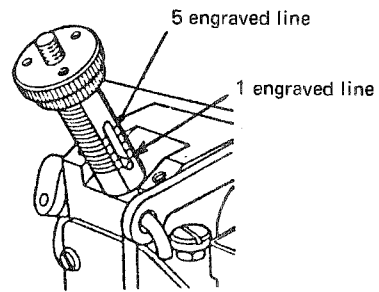
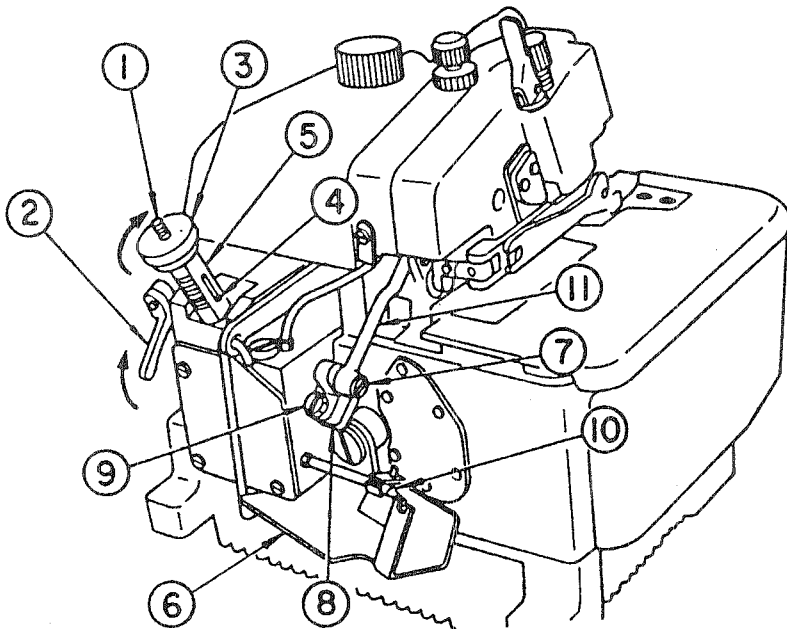

How to adjust	Phenomena caused by the changes in adjustment standard
<p>1. Lift stopper arm (2) to loosen shaft (1).</p> <p>2. Adjust the feed ratio by turning nut (3).</p> <p>3. Don't forget to push down stopper arm (2) fastening shaft (1) after each adjustment.</p> <p>How to adjust the feed ratio to 1:2</p> <p>4. Remove cover (6) and fix hinge screw (7) to the hinge at the upper part of top feed arm (C) (8).</p> <p>(Caution) Fix the hinge screw without loosening setscrew (9) of the feed arm (C).</p> <p>5. Replace cover (6). Set in the way that oil felt (10) rests in top feed link (11).</p> <p>6. Adjust the differential feed ratio following the directions given in 1. to 3. above.</p> <p>(Caution) If you use the machine at the feed ratio of 1:2, ensure that the stitch length is less than 3.0 mm.</p>	<p>1. If the differential feed ratio is too small;</p> <ul style="list-style-type: none"> ○ The effect of irregular stitch prevention may be reduced. <p>2. If the feed ratio is too large, on the contrary;</p> <ul style="list-style-type: none"> ○ The machine may feed the upper cloth more than the lower one to cause irregular stitches with most fabrics. ○ Some fabrics may be scratched by the top feed dog.

Adjustment standard

- (2) **Pressure of the top feed dog**
Standard height of screw (B) ① protruding is 24.5 to 25.5 mm.

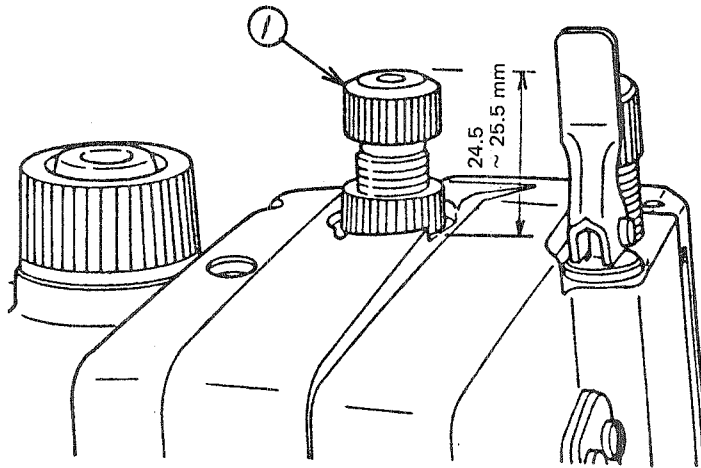

- (3) **Timing of the looper thread cam**
The right corner (A) of cam ② is at the level of the upper face of thread guide ① when the needle is in the highest point.

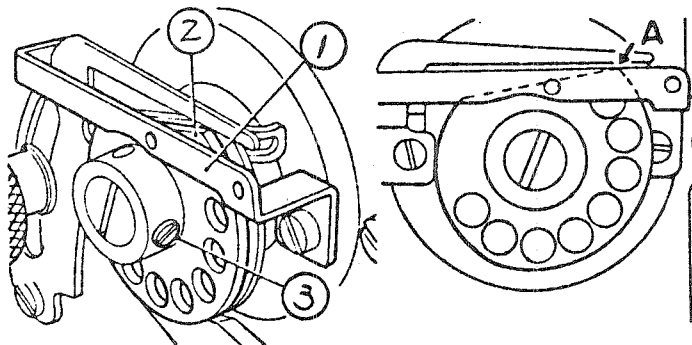

How to adjust	Phenomena caused by the changes in adjustment standard
<p>Adjust the pressure of the top feed dog with screw (B) ①, if a higher feeding power is required.</p> <p>(Caution) In order to prevent noise and inefficiency of the top feed dog, don't let screw (B) project more than 25.5 mm from the bottom of the nut. Also, if the top feed dog may jump with a noise in operation, tighten the screw ① until the noise becomes small.</p>	<ol style="list-style-type: none"> 1. If the pressure is too low; <ul style="list-style-type: none"> ○ The top feed dog may jump with a noise. ○ The top feed may fail to feed fabrics properly. 2. If the pressure is too high; <ul style="list-style-type: none"> ○ Some fabrics may be scratched by the top feed dog.
<p>Adjust by loosening two setscrews ③. Set the cam in the middle of the hook.</p>	<ol style="list-style-type: none"> 1. If the timing of the cam is too early; <ul style="list-style-type: none"> ○ Triangular stitch skipping may occur, because it releases the looper thread before the needle passes completely through a triangular loop of the thread. 2. If the timing of the cam is too late; <ul style="list-style-type: none"> ○ It may cause loose stitches or stitch skipping.

5. Adjustment of Top Feed Mechanism

(1) Horizontal motion

Since the horizontal motion of the top feed mechanism depends on the feed shaft, the amount of the top feed varies with that of the bottom feed which is adjustable by the push-button.

1) How to replace the rubber cushion

If the machine in normal operation suddenly makes a greater running noise than usual, check whether the pressure of the top feed dog to the workpiece is adequate (that is, whether the screw (B) doesn't project more than 25.5 mm from the bottom face of the nut.) If it is so, replace the worn rubber cushion by a new one.

a) Remove the following parts from the machine (Fig. 1-1, 1-2):

- ① Frame cover
- ② Cover
- ③ Side cover
- ④ Side cover (A)
- ⑤ Holder
- ⑥ Adjusting screw (B)
- ⑦ Top feed presser bar
- ⑧ Presser foot shaft
- ⑨ Hinge screw in the top feed link (B)
- ⑩ Variable top feed bar assembly (arm and top feed link (B))
- ⑪ Spring
- ⑫ Rubber cushion

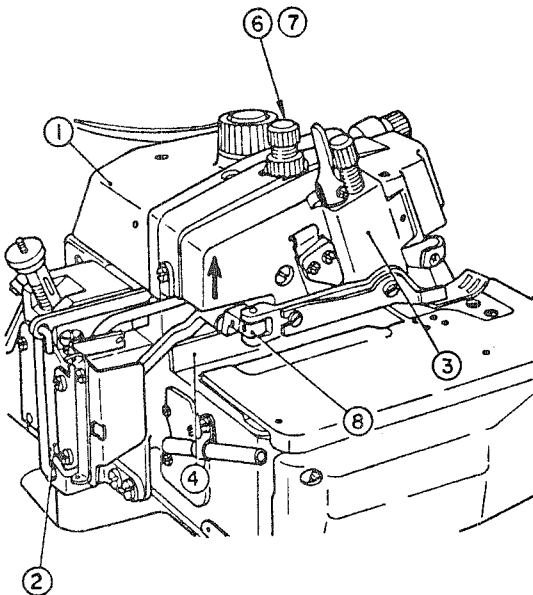

Fig. 1-1

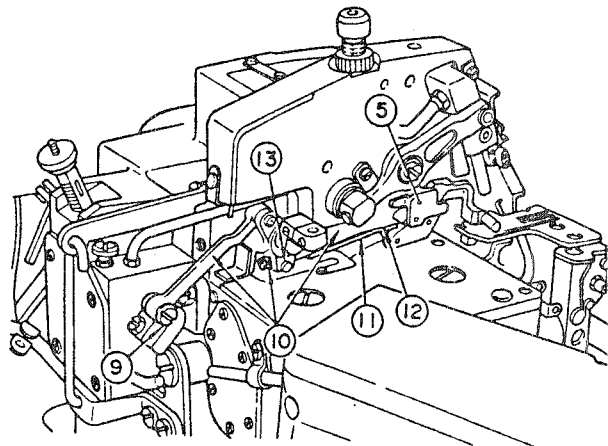

Fig. 1-2

b) Assemble the parts in the following order:

- ① Attach a new rubber cushion ⑫ (Fig. 1-2) to the variable top feed bar.
- ② Attach spring ⑪ (Fig. 1-2) to the variable top feed bar. (Use a washer only for the screw located close to the rubber cushion.)
- ③ Install variable top feed bar (asm.) ⑩ (Fig. 1-2) in its original position. (Ensure that it entirely touches the frame surface and that the oil felt is properly set.)
- ④ Set presser foot shaft ⑧ (Fig. 1-1) temporarily. (Ensure that the variable top feed bar (asm.) moves smoothly.)
- ⑤ Attach holder ⑤ (Fig. 1-2). (Ensure that the variable top feed bar moves smoothly.)
- ⑥ Attach hinge screw ⑨ (Fig. 1-2) to the top feed link (B).
- ⑦ Attach top feed presser bar ⑦ and adjusting screw (B) ⑥ (Fig. 1-1) (Move the top feed presser bar up and down by hand to ensure its smooth motion.)
- ⑧ Fix side cover (A) ④ (Fig. 1-1).
- ⑨ Fix side cover ③ (Fig. 1-1) (Apply sealing substance to the bottom surface of the cover and attach it in place by lifting the arrowed section as shown in Fig. 1-1).
- ⑩ Attach presser foot shaft ⑧ (Fig. 1-1) (Adjust the height of the presser foot.)
- ⑪ Fix cover ② (Fig. 1-1). (Set it in the way that the oil felt rests in the oil hole in the top feed link (B).)
- ⑫ Attach frame cover ① (Fig. 1-1).

(Remarks) If you pull out pin ⑬ in replacing the rubber cushion, don't forget to lock its setscrews after tightening by using "lock-tite" paint.

(5) Position of the variable top feed holder

If top feed arm (C) ②⑤ has been loosened during the adjusting procedures mentioned in (1) and (2) above, be sure to adjust the position of the variable top feed holder.

1) How to adjust

- ① Set the top feed pitch to its minimum of 0.4 mm.
- ② Set the variable top feed holder at its lowest.
- ③ Adjust the position of the variable top feed holder so that a distance of 45.4 mm is kept between the front edge of the throat plate and the center of the ball on the variable top feed holder, and then fix the top feed arm (C).
(The diameter of the ball is 4.0 mm)

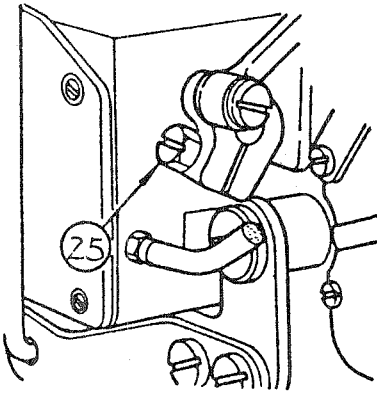
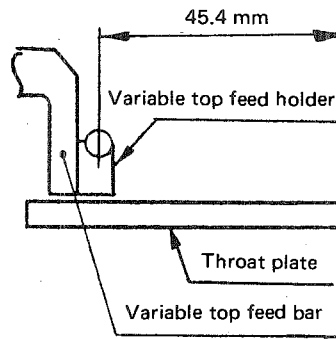

Fig. 3



(6) Position of the top feed dog

When you replace the top feed dog with a new one, attach it as follows:

- ① Fix the feed dog in the middle of the oval adjusting hole with a screw.
- ② If the top feed dog, after the exchange, makes a clatter, or the top differential feed ratio is set to 1:2, ensure that, with the stitch length set to 3.0 mm and the top feed dog advanced to the front end of its stroke, there is a 2.5 mm clearance between the presser foot and the top feed dog. Since the amount of the forward motion is large in this case, it is required to provide a wider clearance of 2.5 mm in front and a clearance of 1.0 mm at the rear.

(Caution) Before you check the clearance, half loosen the adjusting screw mentioned in (2)- ① of pressure of the top feed dog.

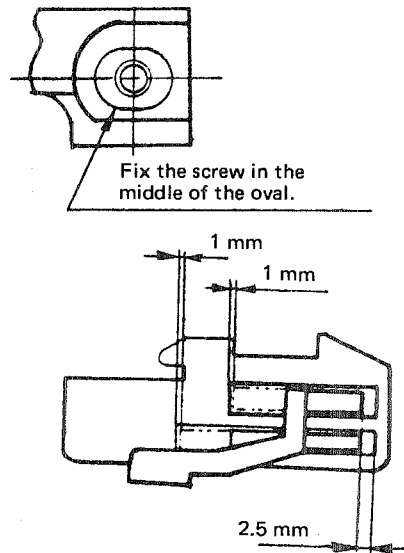

6. Other Things To Be Noted

(1) Table (See Fig. 4)

When you install this machine head on a table designed for MO-800 models, enlarge the installation opening by removing the shadowed part from the table as shown below.

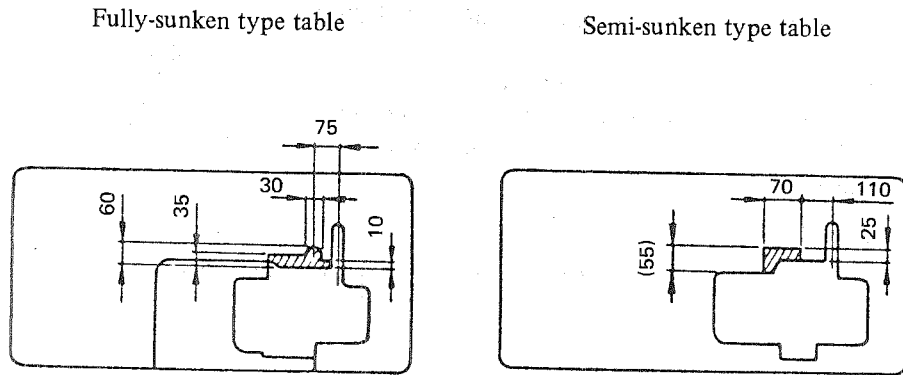

Fig. 4

(2) Replacement of top feed link cover (See Fig. 5)

If you have removed cover (1) to adjust the thread trimmer or the inclination of the main feed dog, set it in the original position after inserting the top end of the oil tube (encircled in the illustration) into the oil hole in the top feed link (B) (2).

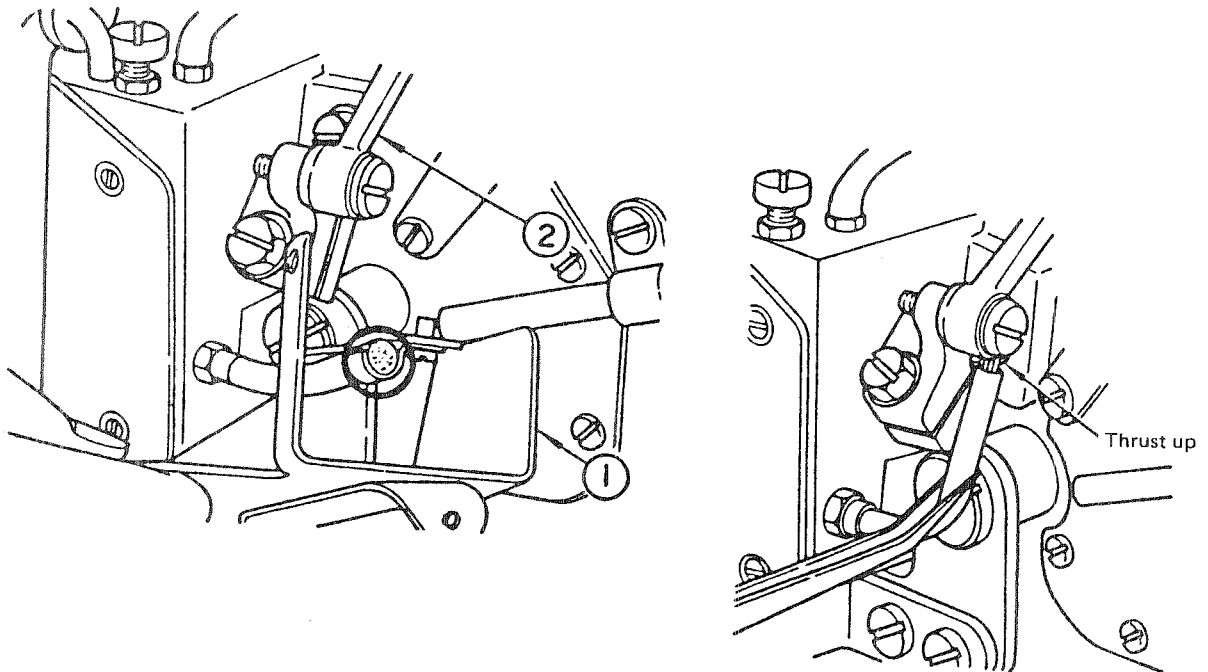

Fig. 5

7. Troubles and Corrective Measures

(1) Fabrics are scratched by the top feed dog

Corrective measures : Use a top feed dog designed for light-weight fabrics (coated with urethan rubber.)

The top feed dog for light-weight fabrics is available for the following models : MOR-816, DD4, FF6, RH6/601 (common with FF6, MOR-814S, BD4)

(2) Fabrics become shiny (marked by the top feed dog)

Corrective measures : Cut away the left row of feed dog tooth by 0.8 mm so that the marks made by the feed dog may be hidden in the stitches.

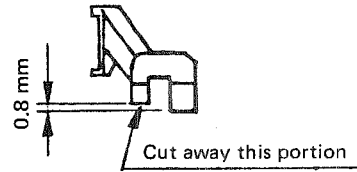

(3) Other troubles

For other stitching troubles refer to the column "Phenomena caused by the changes in adjustment standard" of 4. Adjustment Standard.

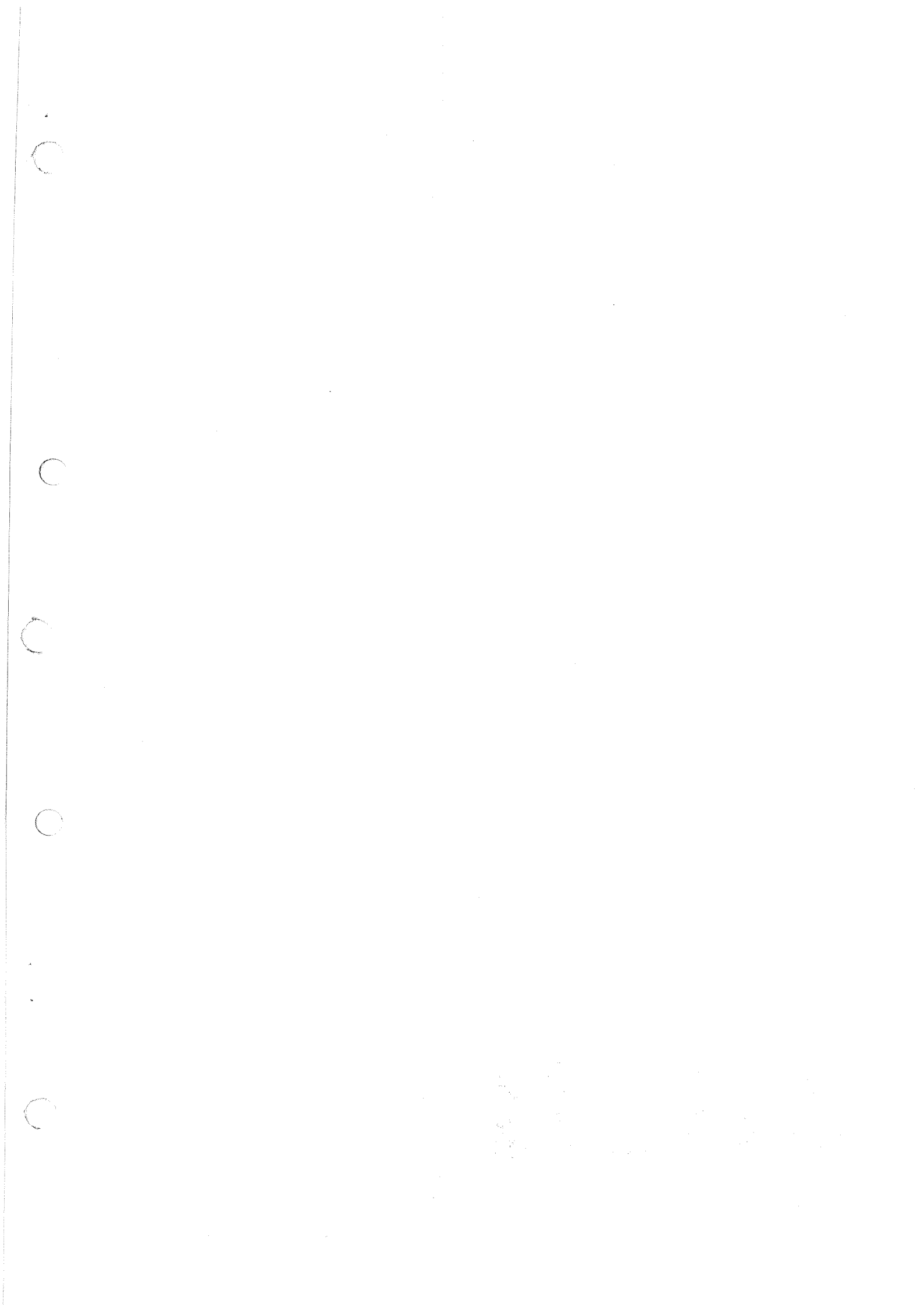

JUKI®

TOKYO JUKI INDUSTRIAL CO., LTD.

Address : 23-3, Kabuki-cho 1-chome, Shinjuku-ku,
Tokyo 160, Japan
Cable : JUKI TOKYO
Telex : 22967, 232-2301
Phone : 03 (205) 1188, 1189, 1190