PFAFF[®] **1442**

Unterklassen-Ausstattung
Subclass parts
Composition des sous-classes
Composición de las subclases

Unterklasse Subclass Subclasse	Ausführung Model Version Tipo de máquina	Nadelabstand in mm Needle gauge in mm Ecartement des aiguilles en mm Distancia entre agujas en mm	Nadelhalter ¹⁰⁷² Needle holder Pince-aiguille Portaagujas	Stoffschieber ⁴ ¹⁰¹ ¹⁰² Feed dog Griffe Transportador inferior
-6/01	BN	1,2-40,0	91-176343-93 ¹⁰ = 1,2-2,8 mm ⁴¹ = 3,2 mm	91-047 563-04 ¹⁰ = 1,2-2,2 mm ⁴¹ = 3,2 mm 91-047 563-04 ¹⁰ = 2,4-4,0 mm 91-047 565-04 ¹⁰ = 4,8-40,0 mm
			91-176068-93 ¹⁰ = 3,2-4,0 mm	
			91-172 590-93 ¹⁰ = 4,8-7,2 mm	
			91-172 840-93 ¹⁰ = 8,0-14,0 mm	
			91-710 004-93 ¹⁰ = 15,2-34,0 mm 91-710 234-93 ¹⁰ = 36,0-40,0 mm	
-6/01-900/56;/61	BN	1,2-24,0	91-176343-93 ¹⁰ = 1,2-2,8 mm ⁴¹ = 3,2 mm	91-059 312-04 ¹⁰ = 1,2-2,8 mm ⁴¹ = 3,2 mm 91-059 313-04 ¹⁰ = 3,2-24,0 mm
			91-176068-93 ¹⁰ = 3,2-4,4 mm	
			91-172 590-93 ¹⁰ = 4,8-7,2 mm	
			91-172 840-93 ¹⁰ = 8,0-14,0 mm	
			91-710 004-93 ¹⁰ = 15,2-24,0 mm	
-6/01	CN	2,2-40,0	91-118 195-93 ¹⁰ = 2,2-2,8 mm ⁴¹ = 3,2 mm	91-047 563-04 ¹⁰ = 2,2-2,8 mm ⁴¹ = 3,2 mm 91-047 563-04 ¹⁰ = 3,2-4,0 mm 91-047 565-04 ¹⁰ = 4,8-40,0 mm
			91-710 004-93 ¹⁰ = 3,2-34,0 mm	
			91-710 234-93 ¹⁰ = 36,0-40,0 mm	
-6/01-900/56;/61	CN	2,2-24,0	91-118 195-93 ¹⁰ = 2,2-2,8 mm ⁴¹ = 3,2 mm	91-059 312-04 ¹⁰ = 2,2-2,8 mm ⁴¹ = 3,2 mm 91-059 313-04 ¹⁰ = 3,2-4,4 mm 91-059 313-04 ¹⁰ = 4,8-5,6 mm (C 2,0) 91-059 313-04 ¹⁰ = 6,0-24,0 mm
			91-710 004-93 ¹⁰ = 3,2-24,0 mm	
-6/03	BN	4,0-40,0	91-176068-93 ¹⁰ = 4,0 mm	91-047 563-04 ¹⁰ = 4,0 mm 91-047 565-04 ¹⁰ = 4,8-40,0 mm
			91-172 590-93 ¹⁰ = 4,8-7,2 mm	
			91-172 840-93 ¹⁰ = 8,0-14,0 mm	
			91-710 004-93 ¹⁰ = 15,2-34,0 mm	
			91-710 234-93 ¹⁰ = 36,0-40,0 mm	
-6/03-900/56;/61	BN	4,0-24,0	91-176064-93 ¹⁰ = 4,0 mm	91-059 313-04 ¹⁰ = 4,0-24,0 mm
			91-172 590-93 ¹⁰ = 4,8-7,2 mm	
			91-172 840-93 ¹⁰ = 8,0-14,0 mm	
			91-710 004-93 ¹⁰ = 15,2-24,0 mm	
-6/03	CN	4,0-40,0	91-710 004-93 ¹⁰ = 4,0-40,0 mm	91-047 563-04 ¹⁰ = 4,0 mm 91-047 565-04 ¹⁰ = 4,8-40,0 mm
-6/03-900/56;/61	CN	4,0-24,0	91-710 004-93 ¹⁰ = 4,0-24,0 mm	91-059 313-04
-19/01	BN	4,8-12,0	91-172 590-93 ¹⁰ = 4,8-7,2 mm	91-047 565-04
			91-172 840-93 ¹⁰ = 8,0-12,0 mm	
-19/01-900/56;/61	BN	4,8-12,0	91-172 590-93 ¹⁰ = 4,8-7,2 mm	91-059 313-04
			91-172 840-93 ¹⁰ = 8,0-12,0 mm	
-19/01	CN	4,8-12,0	91-710 004-93 ¹⁰ = 4,8-12,0 mm	91-047 565-04
-19/01-900/56;/61	CN	4,8-12,0	91-710 004-93 ¹⁰ = 4,8-12,0 mm	91-059 313-04

**Equipement des sous-classes
Unterklassen-Ausstattung**

**Dotación de las subclases
Subclass organization**

Unterklasse Subclass Sous-classe Subclase	Ausführung Modell Variante Tipo de máquina	Suchplatte (1) (10) (102) Needle plate Plaque à aiguille Pieza de aguja	Mähtfuß (1) (102) Presser foot Pied presseur Pie prensateelas	Apparat (5) Attachment Appareil Aparato	Träger Bracket Support Soporte
-6/01	BN	91-158 514-04 $\overline{10}$ = 1,2 - 2,2 mm $\overline{41}$ = 3,2 mm 91-158 514-04 $\overline{10}$ = 2,4 - 4,0 mm 91-158 515-04 $\overline{10}$ = 4,8 - 40,0 mm	91-054 922-03 $\overline{10}$ = 1,2 - 4,0 mm $\overline{41}$ = 3,2 mm 91-054 926-03 $\overline{10}$ = 4,8 - 14,0 mm 91-054 927-03 $\overline{10}$ = 15,2 - 40,0 mm		
-6/01-900/56; /61	BN	91-158 815-04 $\overline{10}$ = 1,2 - 2,8 mm $\overline{41}$ = 3,2 mm 91-158 811-04 $\overline{10}$ = 3,2 - 24,0 mm	91-054 922-03 $\overline{10}$ = 1,2 - 4,0 mm $\overline{41}$ = 3,2 mm 91-054 926-03 $\overline{10}$ = 4,4 - 14,0 mm 91-054 927-03 $\overline{10}$ = 15,2 - 24,0 mm		
-6/01	CN	91-158 514-04 $\overline{10}$ = 2,2 - 2,8 mm $\overline{41}$ = 3,2 mm 91-158 514-04 $\overline{10}$ = 3,2 - 4,0 mm 91-158 515-04 $\overline{10}$ = 4,8 - 40,0 mm	91-054 922-03 $\overline{10}$ = 2,2 - 4,0 mm $\overline{41}$ = 3,2 mm 91-054 926-03 $\overline{10}$ = 4,8 - 14,0 mm 91-054 927-03 $\overline{10}$ = 15,2 - 40,0 mm		
-6/01-900/56; /61	CN	91-158 815-04 $\overline{10}$ = 2,2 - 2,8 mm $\overline{41}$ = 3,2 mm 91-158 811-04 $\overline{10}$ = 3,2 - 24,0 mm	91-054 922-03 $\overline{10}$ = 2,2 - 4,0 mm $\overline{41}$ = 3,2 mm 91-054 926-03 $\overline{10}$ = 4,4 - 14,0 mm 91-054 927-03 $\overline{10}$ = 15,2 - 24,0 mm		
-6/03	BN	91-158 514-04 $\overline{10}$ = 4,0 mm 91-158 515-04 $\overline{10}$ = 4,8 - 40,0 mm	91-055 499-93 $\overline{10}$ = 4,0 - 11,2 mm 91-055 506-93 $\overline{10}$ = 12,0 - 22,0 mm 91-055 507-93 $\overline{10}$ = 24,0 - 40,0 mm		
-6/03-900/56; /61	BN	91-158 811-04 $\overline{10}$ = 4,0 - 24,0 mm	91-055 499-93 $\overline{10}$ = 4,0 - 11,2 mm 91-055 506-93 $\overline{10}$ = 12,0 - 22,0 mm 91-055 507-93 $\overline{10}$ = 24,0 mm		
-6/03	CN	91-158 514-04 $\overline{10}$ = 4,0 mm 91-158 515-04 $\overline{10}$ = 4,8 - 40,0 mm	91-055 499-93 $\overline{10}$ = 4,0 - 11,2 mm 91-055 506-93 $\overline{10}$ = 12,0 - 22,0 mm 91-055 507-93 $\overline{10}$ = 24,0 - 40,0 mm		
-6/03-900/56; /61	CN	91-158 811-04	91-055 499-93 $\overline{10}$ = 4,0 - 11,2 mm 91-055 506-93 $\overline{10}$ = 12,0 - 22,0 mm 91-055 507-93 $\overline{10}$ = 24,0 mm		
-19/01	BN	91-158 515-04	91-055 609-03	91-041 006-23	91-753 936-90
-19/01-900/56; /61	BN	91-158 811-04	91-055 609-03	91-041 006-23	91-753 936-90
-19/01	CN	91-158 515-04	91-055 609-03	91-041 006-23	91-753 936-90
-19/01-900/56; /61	CN	91-158 811-04	91-055 609-03	91-041 006-23	91-753 936-90

Equipement des sous-classes

Dotación de las subclases

Unterklasse Subclass Sous-classe Subclase	Ausführung Model Version Tipo de maquina	Nadelabstand in mm Needle gauge in mm Ecartement des aiguilles en mm Distancia entre agujas en mm	Nadelhalter ^[107] Needle holder Pince-aiguille Portaagujas	Stoffschieber ^[107] Feed dog Griffe Transportador interior
-57/01	BN	4,8 - 10,0	91-172 590-93 $\frac{10}{10}$ = 4,8 - 7,2 mm 91-172 840-93 $\frac{10}{10}$ = 8,0 - 10,0 mm	91-047 565-04
-57/01-900/56;/61	BN	4,8 - 10,0	91-172 590-93 $\frac{10}{10}$ = 4,8 - 7,2 mm 91-172 840-93 $\frac{10}{10}$ = 8,0 - 10,0 mm	91-059 313-04
-57/01	CN	4,8 - 10,0	91-710 004-93	91-047 565-04
-57/01-900/56;/61	CN	4,8 - 10,0	91-710 004-93	91-059 313-04
-58/01	BN	4,8 - 10,0	91-172 590-93 $\frac{10}{10}$ = 4,8 - 7,2 mm 91-172 840-93 $\frac{10}{10}$ = 8,0 - 10,0 mm	91-047 565-04
58/01-900/56;/61	BN	4,8 - 10,0	91-172 590-93 $\frac{10}{10}$ = 4,8 - 7,2 mm 91-172 840-93 $\frac{10}{10}$ = 8,0 - 10,0 mm	91-059 313-04
-58/01	CN	4,8 - 10,0	91-710 004-93	91-047 565-04
-58/01-900/56;/61	CN	4,8 - 10,0	91-710 004-93	91-059 313-04
-61/01	BN	2,4 - 20,0	91-176 068-93 $\frac{10}{10}$ = 2,4 - 4,0 mm 91-172 590-93 $\frac{10}{10}$ = 4,8 - 7,2 mm 91-172 840-93 $\frac{10}{10}$ = 8,0 - 14,0 mm 91-710 004-93 $\frac{10}{10}$ = 15,2 - 20,0 mm	91-047 563-04 $\frac{10}{10}$ = 2,4 - 4,0 mm 91-047 565-04 $\frac{10}{10}$ = 4,8 - 20,0 mm
-61/01-900/56;/61	BN	2,4 - 20,0	91-176 068-93 $\frac{10}{10}$ = 2,4 - 4,0 mm 91-172 590-93 $\frac{10}{10}$ = 4,8 - 7,2 mm 91-172 840-93 $\frac{10}{10}$ = 8,0 - 14,0 mm 91-710 004-93 $\frac{10}{10}$ = 15,2 - 20,0 mm	91-059 313-04
-61/01	CN	3,2 - 20,0	91-710 004-93	91-047 563-04 $\frac{10}{10}$ = 3,2 - 4,0 mm 91-047 565-04 $\frac{10}{10}$ = 4,8 - 20,0 mm
-61/01-900/56;/61	CN	3,2 - 20,0	91-710 004-93	91-059 313-04
-113/02	BN	2,4 - 13,2	91-176 068-93 $\frac{10}{10}$ = 2,4 - 4,0 mm 91-172 590-93 $\frac{10}{10}$ = 4,8 - 7,2 mm 91-172 840-93 $\frac{10}{10}$ = 8,0 - 13,2 mm	91-047 563-04 $\frac{10}{10}$ = 2,4 - 4,0 mm 91-047 565-04 $\frac{10}{10}$ = 4,8 - 13,2 mm

Equipement des sous-classes
Unterklassen-Ausstattung

Dotación de las subclases
Subclass organization

Unterklassen Subclases Subclass	Ausführung Model Version Tipo de máquina	Stichplatte Needle plate Plaque à aiguille Placa de agua	Nähfuß Presser foot Pied presseur Pie prensateelas	Apparat Attachment Appareil Aparato	Bandorientäger Tape reel bracket Supporteur Portarrollos
-57/01	BN	91-158 515-04	91-054 926-03	91-040 317-93	
-57/01-900/56;/61	BN	91-158 811-04	91-054 926-03	91-040 317-93	
-57/01	CN	91-158 515-04	91-054 926-03	91-040 317-93	
-57/01-900/56;/61	CN	91-158 811-04	91-054 926-03	91-040 317-93	
-58/01	BN	91-158 515-04	91-054 926-03	91-040 316-93	
58/01-900/56;/61	BN	91-158 811-04	91-054 926-03	91-040 316-93	
-58/01	CN	91-158 515-04	91-054 926-03	91-040 316-93	
-58/01-900/56;/61	CN	91-158 811-04	91-054 926-03	91-040 316-93	
-61/01	BN	91-158 514-04 $\overline{10}$ = 2,4 - 4,0 mm 91-158 515-04 $\overline{10}$ = 4,8 - 20,0 mm	91-157 658-03 $\overline{10}$ = 2,4 - 14,0 mm 91-157 730-03 $\overline{10}$ = 15,2 - 20,0 mm		91-040 2
-61/01-900/56;/61	BN	91-158 811-04	91-157 658-03 $\overline{10}$ = 2,4 - 14,0 mm 91-157 658-03 $\overline{10}$ = 15,2 - 20,0 mm		91-040 2
61/01	CN	91-158 514-04 $\overline{10}$ = 3,2 - 4,0 mm 91-158 515-04 $\overline{10}$ = 4,8 - 20,0 mm	91-157 658-03 $\overline{10}$ = 3,2 - 14,0 mm 91-157 730-03 $\overline{10}$ = 15,2 - 20,0 mm		91-040 2
61/01-900/56;/61	CN	91-158 811-11-04	91-157 658-03 $\overline{10}$ = 3,2 - 14,0 mm 91-157 730-03 $\overline{10}$ = 15,2 - 20,0 mm		91-040 2
113/02	BN	91-158 514-04 $\overline{10}$ = 2,4 - 4,0 mm 91-158 515-04 $\overline{10}$ = 4,8 - 13,2 mm	91-155 640-03 $\overline{10}$ = 2,4; 2,8 mm $\overline{12}$ = 1,0; 1,5; 2,0 mm 91-155 640-03 $\overline{10}$ = 3,2; 3,6 mm $\overline{12}$ = 1,0 mm 91-057 323-03 $\overline{10}$ = 3,2; 3,6 mm $\overline{12}$ = 1,5 mm 91-057 890-03 $\overline{10}$ = 4,0; 13,2 mm $\overline{12}$ = 1,0; 1,5 mm 91-057 318-03 $\overline{10}$ = 3,2; 3,6 mm $\overline{12}$ = 2,0; 2,5; 3,0; 3,5 mm 91-057 892-03 $\overline{10}$ = 4,0 - 13,2 mm $\overline{12}$ = 2,0; 2,5; 3,0; 3,5 mm	$\overline{60}$ $\overline{12/2}$	

Unterklassen-Ausstattung

Subclass Organization

Unterklasse Subclass Sous-classe Subclase	Ausführung Model Version Tipo de máquina	Nadelabstand in mm Needle gauge in mm Écartement des aiguilles en mm Distancia entre agujas en mm	Nadelhalter ^{10/2} Needle holder Pince-aiguille Puntaaguja	Stoffschieber ⁴ ^{10/1} ^{10/2} Feed dog Griffe Transportador inferior
-113/02-900/56;/61	BN	2,4 - 13,2	91-176 068-93 ¹⁰ = 2,4 - 4,0 mm 91-172 590-93 ¹⁰ = 4,8 - 7,2 mm 91-172 840-93 ¹⁰ = 8,0 - 13,2 mm	91-059 313-04
-113/02	CN	3,2 - 13,2	91-710 004-93	91-047 563-04 ¹⁰ = 3,2 - 4,0 mm 91-047 565-04 ¹⁰ = 4,8 - 13,2 mm
-113/02-900/56;/61	CN	3,2 - 13,2	91-710 004-93	91-059 313-04

⁴ = Ausführung angeben
= indicate model
= Préciser la version
= Indiquez el tipo de máquina

^{10/2} = Nadelabstand bei Bestellung angeben
= State needle gauge on order
= Indiquer écartement des aiguilles à la commande
= Indiquez en los pedidos la distancia entre agujas

⁴¹ = Nadel diagonalabstand
= Diagonal needle distance
= Espacement diagonal des aiguilles
= Distancia diagonal entre agujas

¹⁰ = Nadelabstand
= Needle gauge
= Écartement des aiguilles
= Distancias entre agujas

¹² = Absteppbreite
= Stitching margin
= Relarge de couture
= Margen de costura

⁶⁰ = Wahlweise
= Optional
= Au choix
= Opcional

^{10/1} = je nach Nadelabstand ändert sich die Form
(z.B. beim Stoffschieber die Anzahl
der Zahnreihen)
= Certain design features change according
to the needle gauge (e.g. the number of tooth
rows on the feed dog)
= La forme est fonction de l'écartement
des aiguilles (par ex. le nombre des rangées
de dents de la griffe)
= La forma varia de acuerdo con la distancia entre agujas

^{12/2} = Absteppbreite bei Bestellung angeben
= Indicate stitching margin on order
= Indiquer le relarge de couture à la commande
= Indiquez el margen de costura en los pedidos

Equipement des sous-classes

Dotación de las subclases

Unterklassen-Ausstattung

Subclass organization

Sous-classe Subclass	Ausführung Model Version Tipo de máquina	Stichplatte Handle plate Placa a signalle Placa de aguja	Altimeter Altimètre Piezometre Pie prenastelna
3/02-900/56;/61	BN	91-158 811-04	91-155 640-03 $\overline{10}$ = 2.4; 2.8 mm $\overline{12}$ = 1.0; 1.5; 2.0 mm 91-155 640-03 $\overline{10}$ = 3.2; 3.6 mm $\overline{12}$ = 1.0 mm 91-057 323-03 $\overline{10}$ = 3.2; 3.6 mm $\overline{12}$ = 1.5 mm 91-057 890-03 $\overline{10}$ = 4.0 - 13.2 mm $\overline{12}$ = 1.0; 1.5 mm 91-057 318-03 $\overline{10}$ = 3.2; 3.6 mm $\overline{12}$ = 2.0; 2.5; 3.0; 3.5 mm 91-057 892-03 $\overline{10}$ = 4.0 - 13.2 mm $\overline{12}$ = 2.0; 2.5; 3.0; 3.5 mm
3/02	CN	91-158 514-04 $\overline{10}$ = 3.2 - 4.0 mm 91-158 515-04 $\overline{10}$ = 4.8 - 13.2 mm	91-155 640-03 $\overline{10}$ = 3.2; 3.6 mm $\overline{12}$ = 1.0 mm 91-057 323-03 $\overline{10}$ = 3.2; 3.6 mm $\overline{12}$ = 1.5 mm 91-057 318-03 $\overline{10}$ = 3.2; 3.6 mm $\overline{12}$ = 2.0; 2.5; 3.0; 3.5 mm 91-057 890-03 $\overline{10}$ = 4.0 - 13.2 mm $\overline{12}$ = 1.0; 1.5 mm 91-057 892-03 $\overline{10}$ = 4.0 - 13.2 mm $\overline{12}$ = 2.0; 2.5; 3.0; 3.5 mm
3/02-900/56;/61	CN	91-158 811-04	91-155 640-03 $\overline{10}$ = 3.2; 3.6 mm $\overline{12}$ = 1.0 mm 91-057 323-03 $\overline{10}$ = 3.2; 3.6 mm $\overline{12}$ = 1.5 mm 91-057 318-03 $\overline{10}$ = 3.2; 3.6 mm $\overline{12}$ = 2.0; 2.5; 3.0; 3.5 mm 91-057 890-03 $\overline{10}$ = 4.0 - 13.2 mm $\overline{12}$ = 1.0; 1.5 mm 91-057 892-03 $\overline{10}$ = 4.0 - 13.2 mm $\overline{12}$ = 2.0; 2.5; 3.0; 3.5 mm

Unterklassen-Übersicht/Table of subclasses/Table des sous-classes/Tabla de subclases

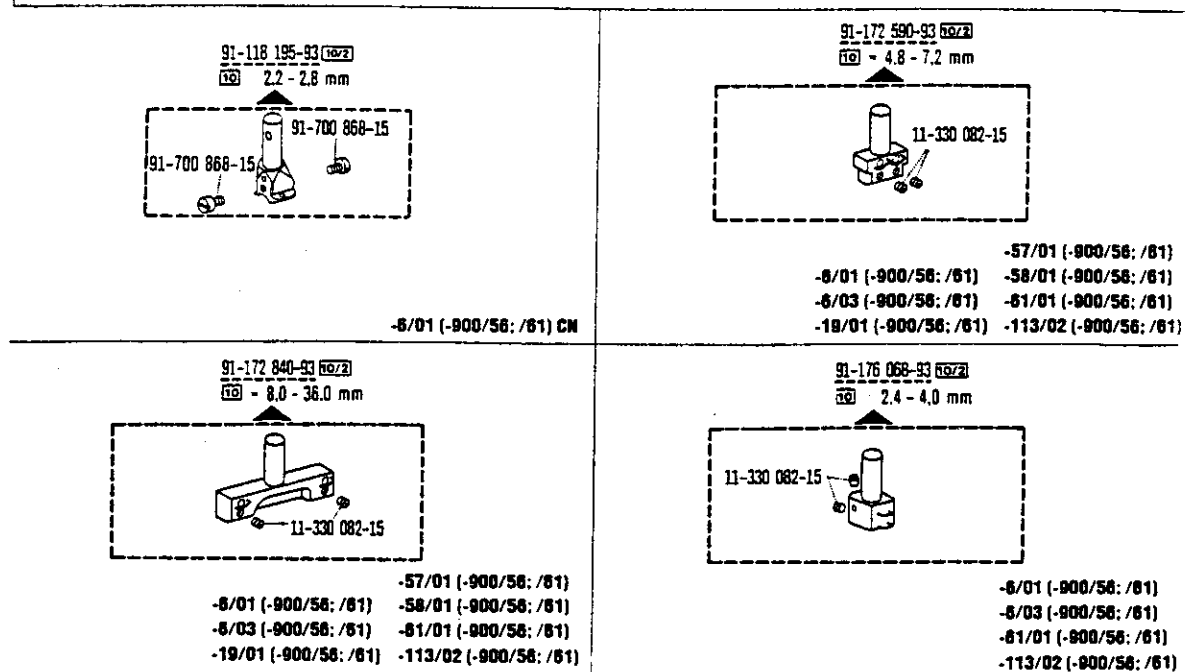

91-176 343-93 ^{10/2}
¹⁰ = 1,2 - 2,8 mm

11-330 082-15

11-330 082-15

-6/01 (-900/56; /61)

91-710 004-93 ^{10/2}
¹⁰ = 4,0 - 40,0 mm

91-173 664-15

91-173 664-15

-57/01 (-900/56; /61)
 -6/01 (-900/56; /61) -58/01 (-900/56; /61)
 -6/03 (-900/56; /61) -61/01 (-900/56; /61)
 -19/01 (-900/56; /61) -113/02 (-900/56; /61)

91-710 234-93 ^{10/2}
¹⁰ = 36,0 - 40,0 mm

91-173 664-15

91-173 664-15

-6/01
 -6/03

91-047 563-04 ⁴ ^{10/2}
¹⁰ = 1,2 - 2,0 mm ¹⁰ = 2,4 - 4,0 mm
⁴¹ = 3,2 mm

91-047 563-04

-6/01
 -6/03
 -61/01
 -113/02

91-047 565-04 ⁴ ^{10/1} ^{10/2}
¹⁰ = 4,8 - 40,0 mm

91-047 565-04

-6/01
 -6/03
 -19/01
 -57/01
 -58/01
 -61/01
 -113/02

91-059 312-04 ⁴ ^{10/2}
¹⁰ = 1,2 - 2,8 mm
⁴¹ = 3,2 mm

91-059 312-04

-6/01-900/56; /61

91-059 313-04 ⁴ ^{10/1} ^{10/2}
¹⁰ = 3,2 - 4,4 mm ¹⁰ = 4,8 - 24,0 mm

91-059 313-04

-6/01 (-900/56; /61)
 -6/03 (-900/56; /61)
 -19/01 (-900/56; /61)
 -57/01 (-900/56; /61)
 -58/01 (-900/56; /61)
 -61/01 (-900/56; /61)
 -113/02 (-900/56; /61)

91-158 514-04 ⁴ ^{10/2}
¹⁰ = 1,2 - 4,0 mm

91-158 514-04

-6/01
 -6/03
 -61/01
 -113/02

91-158 515-04 ⁴ ^{10/1} ^{10/2}
¹⁰ = 4,8 - 40,0 mm

91-158 515-04

-6/01
 -6/03
 -19/01
 -57/01
 -58/01
 -61/01
 -113/02

91-158 811-04 ⁴ ^{10/1} ^{10/2}
¹⁰ = 2,4 - 8,0 mm

91-158 811-04

-6/01-900/56; /61
 -6/03-900/56; /61
 -19/01-900/56; /61
 -57/01-900/56; /61
 -58/01-900/56; /61
 -61/01-900/56; /61
 -113/02-900/56; /61

91-158 815-04 ⁴ ^{10/2}
¹⁰ = 1,2 - 2,8 mm

91-158 815-04

-6/01-900/56; /61

91-054 922-03 ⁴ ^{10/2}

91-054 922-03

-6/01 (-900/56; /61)

91-054 926-03 ⁴ ^{10/2}

91-054 926-03

-6/01 (-900/56; /61)
 -57/01 (-900/56; /61)
 -58/01 (-900/56; /61)

91-054 927-03 ⁴ ^{10/2}

91-054 927-03





-6/01 (-900/56; /61)

91-055 499-93 ⁴ ^{10/2}

91-055 499-93

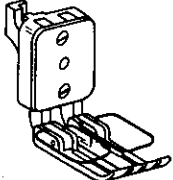
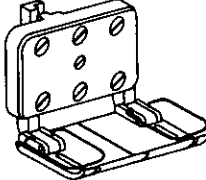
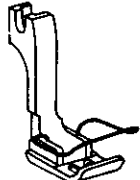
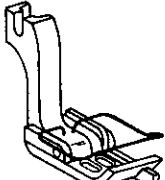
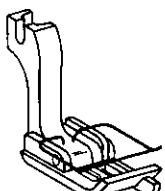
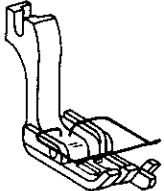
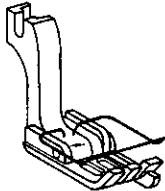
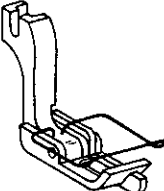
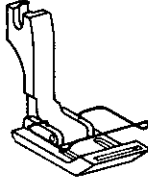
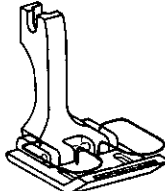
-6/03 (-900/56; /61)

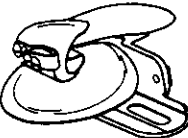
Unterklassen-Ubersicht/ Table of subclasses/ Table des sous-classes/ Tabla de subclasses

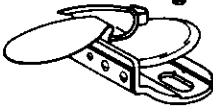
<p>91-055 506-93 4 10/2</p>  <p>-6/03 (-900/56; /61)</p>	<p>91-055 507-93 4 10/2</p>  <p>-6/03 (-900/56; /61)</p>	<p>91-055 609-03 4 10/2</p>  <p>-19/01 (-900/56; /61)</p>	<p>91-057 318-03 4 10/2 12/2</p>  <p>-113/02 (-900/56; /61)</p>
<p>91-057 323-03 4 10/2 12/2</p>  <p>-113/02 (-900/56; /61)</p>	<p>91-057 890-03 4 10/2 12/2</p>  <p>-113/02 (-900/56; /61)</p>	<p>91-057 892-03 4 10/2 12/2</p>  <p>-113/02 (-900/56; /61)</p>	<p>91-155 640-03 4 10/2 12/2</p>  <p>-113/02 (-900/56; /61)</p>
<p>91-157 658-03 4 10/2</p>  <p>-61/01 (-900/56; /61)</p>		<p>91-157 730-03 4 10/2</p>  <p>-61/01 (-900/56; /61)</p>	
<p>91-040 316-93 5 10/2</p> <p>91-000 521-25 </p>  <p>-58/01 (-900/56; /61)</p>		<p>91-040 317-93 5 10/2</p> <p>91-000 521-25 </p>  <p>-57/01 (-900/56; /61)</p>	

91-041 006-23 5

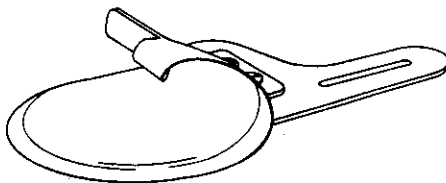

-10/01 (-900/56; /61)

Unterklassen-Übersicht/Table of subclasses/Table des sous-classes/Tabla de subclasses

91-753 936-90

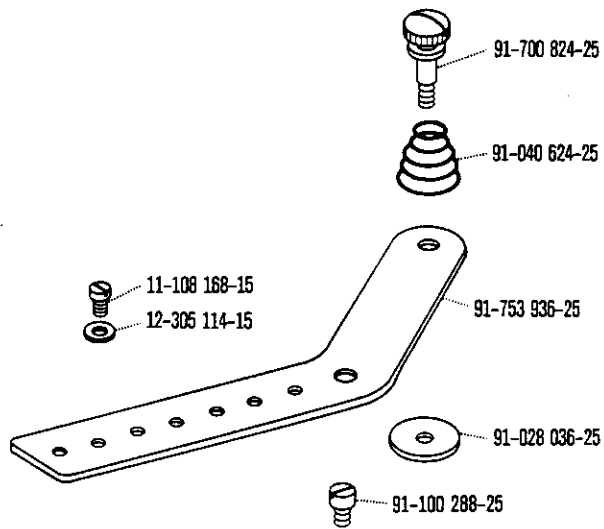

-19/01 (-900/56; /61)

91-040 207-91

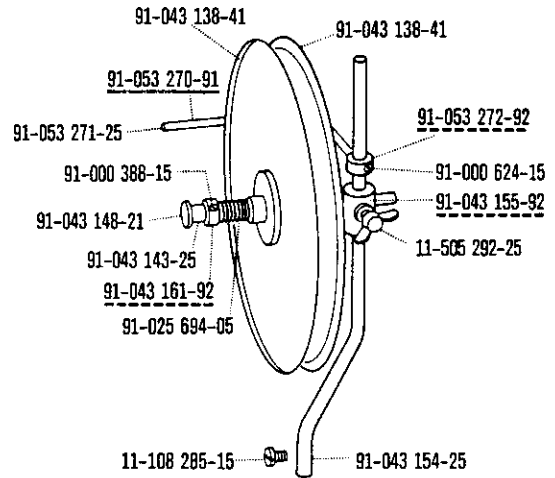

-61/01 (-900/56; /61)