PFAFF[®] **1445-706/07 P**
1445-706/07

Unterklassen-Ausstattung
Subclass parts
Composition des sous-classes
Composición de las subclases

Unterklassen-Ausstattung

Subclass organization

Équipement des sous-classes

Dotación de las subclases

Unterklassen Subclass Sous-classe Subclase	Ausführung Model Version Tipo de maquina	Nadelstange Needle bar Barre à aiguille Barra de aguja	Stoffschieber ^[5] Feed dog Griffe Transportador inferior	Stichplatte ^[4] Needle plate Plaque à aiguille Placa de aguja	Stoffrührfuß ^[4] Presser foot Pied presseur Pie prensatalas
-2/01 <u>12</u> = 1,5 - 5 mm	BN; CN	91-174 249-92	91-059 311-04	91-158 543-04	91-049 832-93 <u>12/2</u>
-2/01-900/56;/61 <u>12</u> = 1,5 - 5 mm	BN; CN	91-174 249-92	91-059 299-04	91-158 764-04	91-049 832-93 <u>12/2</u>
-2/04 <u>12</u> = 1 - 5 mm	BN; CN	91-174 249-92	91-059 311-04	91-158 543-04	91-049 832-93 <u>12/2</u>
-2/04-900/56;/61 <u>12</u> = 1 - 5 mm	BN; CN	91-174 249-92	91-059 299-04	91-158 764-04	91-049 832-93 <u>12/2</u>
-2/24 <u>12</u> = 1 - 5 mm	BN; CN	91-174 249-92	91-059 311-04	91-158 543-04	91-049 826-93 <u>12/2</u>
-2/24-900/56;/61 <u>12</u> = 1 - 5 mm	BN; CN	91-174 249-92	91-059 299-04	91-158 764-04	91-049 826-93 <u>12/2</u>
-6/01	BN; CN	91-174 249-92	91-059 311-04 x 3,9	91-158 543-04 x 4,0	91-049 802-93
-6/01-900/56;/61	BN; CN	91-174 249-92	91-059 299-04 x 3,9	91-158 764-04 x 4,0	91-049 802-93
-6/01	BN 10; CN 10	91-174 249-92	91-059 724-04	91-158 802-04	91-049 841-93
-6/01-900/56;/61	BN 10; CN 10	91-174 249-92	91-059 719-04	91-158 790-04	91-049 841-93
-6/07	BN; CN	91-174 249-92	91-059 311-04 x 3,9	91-158 543-04 x 4,0	91-049 772-93 x 3,2
-6/07-900/56;/61	BN; CN	91-174 249-92	91-059 299-04 x 3,9	91-158 764-04 x 4,0	91-049 772-93 x 3,2
-6/07	BN 10; CN 10	91-174 249-92	91-059 724-04	91-158 802-04	91-049 772-93 x 3,2
-6/07-900/56;/61	BN 10; CN 10	91-174 249-92	91-059 719-04	91-158 790-04	91-049 772-93 x 3,2
-6/11	BN; CN	91-174 249-92	91-059 765-04	91-158 958-04	91-049 832-93
-6/11-900/56;/61	BN; CN	91-174 249-92	91-059 743-04	91-158 864-04	91-049 832-93
-6/27	BN; CN	91-174 249-92	91-059 688-04 x 10	91-158 699-04 x 10	91-049 772-93 x 3,2
-6/27-900/56;/61	BN; CN	91-174 249-92	91-059 316-04 x 10	91-158 813-04 x 10	91-049 772-93 x 3,2
-6/31-900/56;/61	BN; CN	91-174 249-92	91-059 744-04	91-158 865-04	91-049 802-93
-19/04	BN; CN	91-174 249-92	91-059 311-04	91-158 543-04	91-049 802-93
-19/04-900/56;/61	BN; CN	91-174 249-92	91-059 299-04	91-158 542-04	91-049 802-93
-34/01	BN; CN	91-174 249-92	91-059 298-04	91-158 517-04	91-049 803-93
-34/01-900/56;/61	BN; CN	91-174 249-92	91-059 286-04	91-158 763-04	91-049 803-93
-34/07	BN; CN	91-174 249-92	91-059 298-04	91-158 517-04	91-049 804-93
-34/07-900/56;/61	BN; CN	91-174 249-92	91-059 286-04	91-158 763-04	91-049 804-93
-40/01 <u>88</u> = 4 - 10 mm	BN; CN	91-174 249-92	91-059 688-04 x 10,0	91-158 699-04 x 10,0	91-049 794-93 <u>5</u> <u>88/2</u>
-40/01-900/56;/61 <u>88</u> = 4 - 10 mm	BN; CN	91-174 249-92	91-059 316-04 x 10,0	91-158 813-04 x 10,0	91-049 794-93 <u>5</u> <u>88/2</u>
-40/05 <u>88</u> = 4 - 10 mm	BN; CN	91-174 249-92	91-059 688-04 x 10,0	91-158 699-04 x 10,0	91-049 794-93 <u>5</u> <u>88/2</u>
-40/05-900/56;/61 <u>88</u> = 4 - 10 mm	BN; CN	91-174 249-92	91-059 316-04 x 10,0	91-158 813-04 x 10,0	91-049 794-93 <u>5</u> <u>88/2</u>

* = auch ohne P (Hüpftransport) lieferbar
 = also available without P (4-motion drop feed)
 = également livrable sans P (griffe sautillante)
 = también sin P (arrastre a matro tiempos) suministrable

Equipement des sous-classes
Unterklassen-Ausstattung

Dotación de las subclases
Subclass organization

Sous-classe Subclase	Ausführung Model Version Tipo de máquina	Stoffschlebeaufl. Vibrating presser Pied entranneur Transportador superior	Apparat Attachment Appareil Aparato	Träger Bracket Support Soporte	Lineal Esquida Guía-borda Guía recta	Schieber, links Slide, left Glissière, gauche Corredora, izquierda	Schieber, rechts Slide, right Glissière, droite Corredora, derecha	Fingerschutz Finger guard Protecte-douglas Salvadores
06/07 P*								
11 1,5 - 5 mm	BN; CN	91-049 394-93 <u>1271</u>			91-053 617-93	91-118 835-24 x 0,8	91-118 844-23 x 0,8	91-155 426-91
11-900/56; /61 1,5 - 5 mm	BN; CN	91-049 394-93 <u>1271</u>			91-053 617-93	91-173 907-24 x 0,8	91-173 908-23 x 0,8	91-155 426-91
14 1 - 5 mm	BN; CN	91-049 394-93 <u>1272</u>			99-117 880-91	91-118 835-24 x 0,8	91-118 844-24 x 0,8	91-155 426-91
14-900/56; /61 1 - 5 mm	BN; CN	91-049 394-93 <u>1272</u>			99-117 880-91	91-173 907-24 x 0,8	91-173 906-24 x 0,8	91-155 426-91
24 1 - 5 mm	BN; CN	91-049 434-93 <u>1272</u>			99-117 880-91	91-118 835-24 x 0,8	91-118 844-24 x 0,8	91-155 426-91
24-900/56; /61 1 - 5 mm	BN; CN	91-049 434-93 <u>1272</u>			99-117 880-91	91-173 907-24 x 0,8	91-173 906-24 x 0,8	91-155 426-91
31	BN; CN	91-049 394-93 x 4,0				91-118 835-24 x 0,8	91-118 844-24 x 0,8	91-155 422-91
31-900/56; /61	BN; CN	91-049 394-93 x 4,0				91-173 907-24 x 0,8	91-173 906-24 x 0,8	91-155 422-91
31	BN 10; CN 10	91-049 394-93 x 4,0				91-118 835-24 x 0,8	91-118 844-24 x 0,8	91-155 466-91
31-900/56; /61	BN 10; CN 10	91-049 394-93 x 4,0				91-173 907-24 x 0,8	91-173 906-24 x 0,8	91-155 466-91
31	BN 10; CN 10	91-049 394-93 x 4,0				91-118 835-24 x 0,8	91-118 844-24 x 0,8	91-155 422-91
31-900/56; /61	BN 10; CN 10	91-049 394-93 x 4,0				91-173 907-24 x 0,8	91-173 906-24 x 0,8	91-155 422-91
07	BN; CN	91-049 394-93 x 4,0				91-118 835-24 x 0,8	91-118 844-24 x 0,8	91-155 466-91
07-900/56; /61	BN; CN	91-049 394-93 x 4,0				91-173 907-24 x 0,8	91-173 906-24 x 0,8	91-155 422-91
07	BN 10; CN 10	91-049 394-93 x 4,0				91-118 835-24 x 0,8	91-118 844-24 x 0,8	91-155 466-91
07-900/56; /61	BN 10; CN 10	91-049 394-93 x 4,0				91-173 907-24 x 0,8	91-173 906-24 x 0,8	91-155 466-91
07	BN 10; CN 10	91-049 394-93 x 4,0				91-118 835-24 x 0,8	91-118 844-24 x 0,8	91-155 422-91
07-900/56; /61	BN 10; CN 10	91-049 394-93 x 4,0				91-173 907-24 x 0,8	91-173 906-24 x 0,8	91-155 422-91
11	BN; CN	91-049 394-93 x 4,0				91-118 835-24 x 0,8	91-118 844-24 x 0,8	91-155 422-91
11-900/56; /61	BN; CN	91-049 394-93 x 4,0				91-173 907-24 x 0,8	91-173 906-24 x 0,8	91-155 422-91
27	BN; CN	91-049 394-93 x 4,0				91-118 835-24 x 0,8	91-118 844-24 x 0,8	91-155 422-91
27-900/56; /61	BN; CN	91-049 394-93 x 4,0				91-173 907-24 x 0,8	91-173 906-24 x 0,8	91-155 422-91
31-900/56; /61	BN; CN	91-049 394-93				91-118 835-24 x 0,8	91-118 844-24 x 0,8	91-155 422-91
1/04	BN; CN	91-049 394-93	91-053 819-23	91-753 936-90		91-118 835-24 x 0,8	91-118 844-24 x 0,8	91-155 422-91
1/04-900/56; /61	BN; CN	91-049 394-93	91-053 819-23	91-753 936-90		91-173 907-24 x 0,8	91-173 906-24 x 0,8	91-155 422-91
1/01	BN; CN	91-049 395-93				91-118 835-24 x 0,8	91-118 844-24 x 0,8	91-155 422-91
1/01-900/56; /61	BN; CN	91-049 395-93				91-173 907-24 x 0,8	91-173 906-24 x 0,8	91-155 422-91
1/07	BN; CN	91-049 395-93				91-118 835-24 x 0,8	91-118 844-24 x 0,8	91-155 422-91
1/07-900/56; /61	BN; CN	91-049 395-93				91-173 907-24 x 0,8	91-173 906-24 x 0,8	91-155 422-91
0/01 = 4 - 10 mm	BN; CN	91-049 382-93 <u>3 5872</u>	91-046 330-93	91-156 263-90		91-118 835-24 x 0,8	91-173 906-24 x 0,8	91-155 429-9
0/01-900/56; /61 = 4 - 10 mm	BN; CN	91-049 382-93 <u>3 5872</u>	91-046 330-93	91-156 263-90		91-173 907-24 x 0,8	91-173 906-24 x 0,8	91-155 429-9
0/05 = 4 - 10 mm	BN; CN	91-049 382-93 <u>3 5872</u>	91-053 256-93	91-156 263-90		91-118 835-24 x 0,8	91-173 906-24 x 0,8	91-155 429-9
0/05-900/56; /61 = 4 - 10 mm	BN; CN	91-049 382-93 <u>3 5872</u>	91-053 256-93	91-156 263-90		91-173 907-24 x 0,8	91-173 906-24 x 0,8	91-155 429-9

Unterklassen-Ausstattung

Subclass organization

Equipement des sous-classes

Dotación de las subclases

Unterklasse Subclass Sous-classe Subclase	Ausführung Model Version Tipo de máquina	Nadelstange Needle bar Barre à aiguille Barra de aguja	Stoffschieber ⁴ Feed dog Griffe Transportador inferior	Stichplatte ⁴ Needle plate Plaque à aiguille Placa de aguja	Stoffdrückfuß ⁴ Presser foot Pied presseur Pie prensante	Stoffschieberfuß ⁴ Vibrator Pied enlaineur Transportador superior
-706/07 P*						
-40/10 ⁶⁸ = 4 - 6 mm	BN; CN	91-174 249-92	91-059 321-04 ^{68/2}	91-158 773-04 ^{68/2}	91-049 781-93 ⁵ ^{68/2}	91-049 393-93 ⁵ ^{68/2}
-40/10-900/56; /61 ⁶⁸ = 4 - 6 mm	BN; CN	91-174 249-92	91-059 321-04 ^{68/2}	91-158 812-04 ^{68/2}	91-049 781-93 ⁵ ^{68/2}	91-049 393-93 ⁵ ^{68/2}
-40/12 ⁶⁸ = 4 - 10 mm	BN; CN	91-174 249-92	91-059 688-04 x 10,0	91-158 699-04 x 10,0	91-049 782-93 ⁵ ^{68/2}	91-049 402-93 ⁵ ^{68/2}
-40/12-900/56; /61 ⁶⁸ = 4 - 10 mm	BN; CN	91-174 249-92	91-059 316-04 x 10,0	91-158 813-04 x 10,0	91-049 782-93 ⁵ ^{68/2}	91-049 402-93 ⁵ ^{68/2}
-40/14	BN; CN	91-174 249-92	91-059 416-04	91-158 986-04	91-049 859-93	91-049 490-93
-40/14-900/56; /61	BN; CN	91-174 249-92	91-059 357-04	91-158 724-04	91-049 859-93	91-049 490-93
-40/41	BN; CN	91-174 249-92	91-059 311-04	91-158 543-04	91-049 832-93	91-049 394-93
-40/41-900/56; /61	BN; CN	91-174 249-92	91-059 299-04	91-158 764-04	91-049 832-93	91-049 394-93

-706/07

-17/01	BN; CN	91-174 249-92	91-059 383-04	91-158 870-04	91-049 852-93	91-049 483-93
-39/01	BN; CN	91-174 249-92	91-059 383-04	91-158 870-04	91-049 852-93	91-049 483-93
-39/21	BN; CN	91-174 249-92	91-059 383-04	91-158 870-04	91-049 852-93	91-049 483-93





* = auch ohne P (Hüpftransport) lieferbar
 = also available without P (4-motion drop feed)
 = e galement livrable sans P (griffe sautillante)
 = tambien sin P (arrastré a matro tiempos) suministrable

⁴ = Ausführung angeben
 = indicate model
 = Préciser la version
 = Indíquese el tipo de máquina

⁵ = Nähmuster einsenden
 = Submit sewing sample
 = Joindre échantillons de couture
 = Envíese muestra de costura

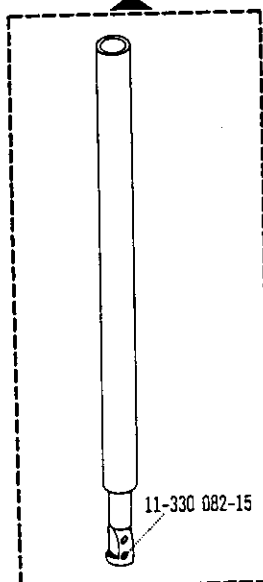
¹² = Absteppbreite
 = Stitching margin
 = Relarge de couture
 = Margen de costura

Unterklassen-Übersicht/ Table of subclasses/ Table des sous-classes/ Tabla de subclases

 <p>91-174 249-92</p> <p>11-330 082-15</p>	<p>91-059 286-04⁴</p> 	<p>91-059 298-04⁴</p> 	
	<p>-2/01 (-900/56; /61) -2/04 (-900/56; /61) -2/24 (-900/56; /61) -6/01 (-900/56; /61) -6/07 (-900/56; /61) -6/11 (-900/56; /61) -6/27 (-900/56; /61) -6/31-900/56; /61</p>	<p>-34/01-900/56; /61 -34/07-900/56; /61</p>	<p>-34/01 -34/07</p>
	<p>-17/01 (-900/56; /61) -19/04 (-900/56; /61) -34/01 (-900/56; /61) -34/07 (-900/56; /61) -39/01 -39/21 (-900/56; /61) -40/01 (-900/56; /61) -40/05 (-900/56; /61) -40/10 (-900/56; /61) -40/12 (-900/56; /61) -40/14 (-900/56; /61) -40/41 (-900/56; /61)</p>	<p>91-059 299-04⁴</p> 	<p>91-059 311-04⁴</p> 
	<p>-2/01 -2/04 -2/24 -6/01 -6/07 -19/04-900/56; /61 -40/41-900/56; /61</p>	<p>-2/01-900/56; /61 -2/04-900/56; /61 -2/24-900/56; /61 -6/01-900/56; /61 (N10) -6/07-900/56; /61 -19/04-900/56; /61 -40/41-900/56; /61</p>	<p>-2/01 -2/04 -2/24 -6/01 -6/07 -19/04 -40/41</p>

Equipement des sous-classes
Unterklassen-Ausstattung

Dotación de las subclases
Subclass organization

Sous-classe Subclase	Ausführung Model Version Tipo de máquina	Appareil ⁵ Attachment Appareil Aparato	Träger Bracket Support Soporte	Bandrollenträger Tape reel bracket Plateau dérouleur Portarrollos	Lineal Edge guide Guide-board Guía recta	Schieber, links Slide, left Glissière, gauche Corredora, izquierda	Schieber, rechts Slide, right Chissière, droite Corredora, derecha	Fingerschutz Finger guard Protège-doigts Salvadojos
06/07 P*								
'10 4 - 6 mm	BN; CN					91-118 835-24 x 0,8	91-118 844-24 x 0,8	91-155 422-91
'10-900/56; /61 4 - 6 mm	BN; CN					91-173 907-24 x 0,8	91-173 906-24 x 0,8	91-155 422-91
'12 4 - 10 mm	BN; CN					91-118 835-24 x 0,8	91-118 844-24 x 0,8	91-155 433-91
'12-900/56; /61 4 - 10 mm	BN; CN					91-173 907-24 x 0,8	91-173 906-24 x 0,8	91-155 433-91
'14	BN; CN				99-117 880-23	91-118 835-24 x 0,8	91-118 844-24 x 0,8	91-155 433-91
'14-900/56; /61	BN; CN				99-117 880-23	91-173 907-24 x 0,8	91-173 906-24 x 0,8	91-155 433-91
41	BN; CN	91-053 257-93	91-156 263-90			91-118 835-24 x 0,8	91-173 906-24 x 0,8	91-155 426-91
41-900/56; /61	BN; CN	91-053 257-93	91-156 263-90			91-173 907-24 x 0,8	91-173 906-24 x 0,8	91-155 426-91









06/07								
01	BN; CN	91-040 533-24	91-156 269-90	91-043 943-91		91-118 835-24 x 0,8	91-173 294-24 x 0,8	91-155 426-91
01	BN; CN	91-041 969-23	91-156 269-90	91-043 943-91		91-118 835-24 x 0,8	91-173 294-24 x 0,8	91-155 426-91
21	BN; CN	91-041 382-23	91-156 269-90	91-043 943-91		91-118 835-24 x 0,8	91-173 294-24 x 0,8	91-155 426-91

12/2 = Absteppbreite bei Bestellung angeben
= Indicate stitching margin on order
= Indiquer le relarge de couture à la commande
= Indiquese el margen de costura en los pedidos

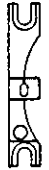































60 = Kederdicke
= Thickness of welting
= Grosseur du bourrelet
= Grosor del vivo

60/2 = Kederdicke bei Bestellung angeben
= Thickness of welting to be stated on order
= Préciser la grosseur du bourrelet à la commande
= Indiquese en los pedidos el grosor del vivo

















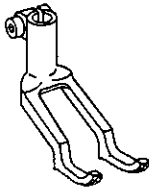



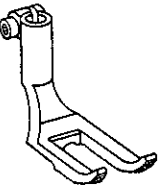







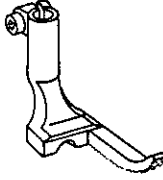

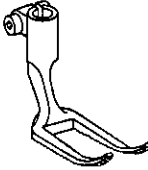

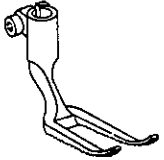

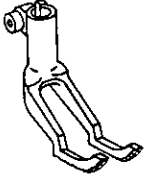

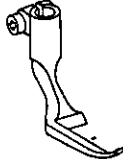
Unterklassen-Übersicht/Table of subclasses/Table des sous-classes/Tabla de subclases

91-059 316-04 4 x 10,0  -6/27-900/56; /61 -40/01-900/56; /61 -40/05-900/56; /61 -40/12-900/56; /61	91-059 321-04 4 60/2  -40/10 (-900/56; /61)	91-059 357-04 4  -40/14-900/56; /61	91-059 383-04 4  -17/01 -39/01 -39/21	91-059 416-04 4  -40/1
91-059 688-04 4 x 10,0  -6/27 -40/01 -40/05 -40/12	91-059 719-04 4  -6/07-900/56; /61 N10	91-059 724-04 4  -6/01 N10 -6/07 N10	91-059 743-04 4  -6/11-900/56; /61	91-059 744-04 4  -6/31-900/56; /6

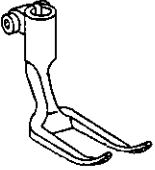

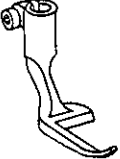

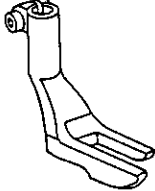

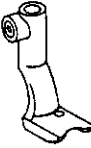





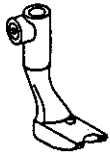

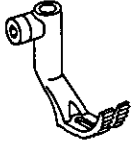

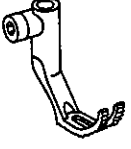



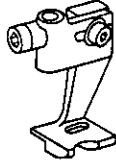

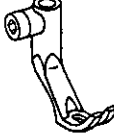

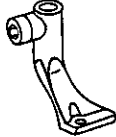

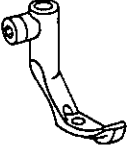

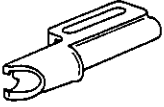

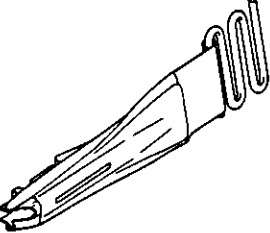
Unterklassen-Übersicht/ Table of subclasses/ Table des sous-classes/ Tabla de subclasses

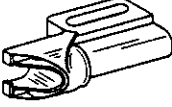
<p>91-059 765-04 </p>  <p>-6/11</p>		<p>91-158 517-04 </p>  <p>-34/01 -34/07</p>	<p>91-158 542-04 </p>  <p>-19/04-900/56; /61</p>
<p>91-158 543-04 </p>  <p>-2/01 -2/04 -2/24 -6/01 -6/07 -19/04 -40/41</p>	<p>91-158 699-04  x 10,0</p>  <p>-6/27 -40/01 -40/05 -40/12</p>	<p>91-158 724-04 </p>  <p>-40/14-900/56; /61</p>	<p>91-158 763-04 </p>  <p>-34/01-900/56; /61 -34/07-900/56; /61</p>
<p>91-158 764-04 </p>  <p>-2/01-900/56; /61 -2/04-900/56; /61 -2/24-900/56; /61 -6/01-900/56; /61 (N10) -6/07-900/56; /61 -40/41-900/56; /61</p>	<p>91-158 773-04  </p>  <p>-40/10</p>	<p>91-158 790-04 </p>  <p>-6/07-900/56; /61 N10</p>	<p>91-158 802-04 </p>  <p>-6/01 N10 -6/07 N10</p>
<p>91-158 812-04  </p>  <p>-40/10-900/56; /61</p>	<p>91-158 813-04  x 10,0</p>  <p>-6/27-900/56; /61 -40/01-900/56; /61 -40/05-900/56; /61 -40/12-900/56; /61</p>	<p>91-158 864-04 </p>  <p>-6/11-900/56; /61</p>	<p>91-158 865-04 </p>  <p>-6/31-900/56; /61</p>

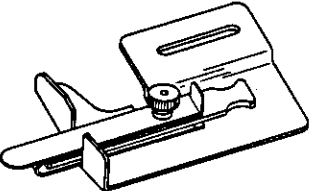
Unterklassen-Ubersicht/ Table of subclasses/ Table des sous-classes/ Tabla de subclases

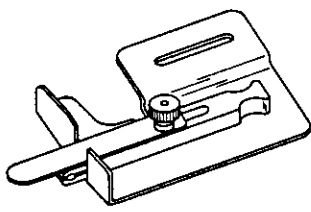
<p>91-158 870-04 </p>  <p>-17/01 -39/01 -39/21</p>	<p>91-158 958-04 </p>  <p>-6/11</p>	<p>91-158 986-04 </p>  <p>-40/14</p>	<p>91-049 772-93  x 3,2</p>  <p>-6/07 (-900/56; /61) (N10) -6/27 (-900/56; /61)</p>
<p>91-049 781-04   </p>  <p>-40/10 (-900/56; /61)</p>	<p>91-049 782-93   </p>  <p>-40/12 (-900/56; /61)</p>	<p>91-049 794-04   </p>  <p>-40/01 (-900/56; /61) -40/05 (-900/56; /61)</p>	<p>91-049 802-93 </p>  <p>-6/01 (-900/56; /61) -6/01-900/56; /61 N10 -6/31-900/56; /61 -19/04 (-900/56; /61)</p>
<p>91-049 803-93 </p>  <p>-34/01 (-900/56; /61)</p>	<p>91-049 804-93 </p>  <p>-34/07 (-900/56; /61)</p>	<p>91-049 826-93  </p>  <p>-2/24 (-900/56; /61)</p>	<p>91-049 832-93  </p>  <p>-2/01 (-900/56; /61) -2/04 (-900/56; /61) -6/11 (-900/56; /61) -40/41 (-900/56; /61)</p>
<p>91-049 841-93 </p>  <p>-6/01 N10</p>	<p>91-049 852-93  </p>  <p>-17/01 -39/01 -39/21</p>	<p>91-049 859-93 </p>  <p>-40/14 (-900/56; /61)</p>	<p>91-049 382-93  </p>  <p>-40/01 (-900/56; /61) -40/05 (-900/56; /61)</p>

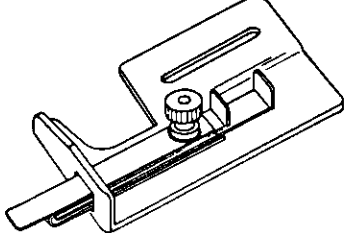
Unterklassen-Übersicht/ Table of subclasses/ Table des sous-classes/ Tabla de subclasses

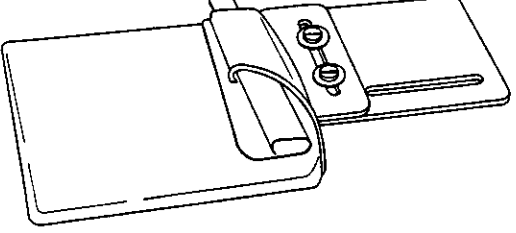
<p>91-049 393-93   </p>  <p>-40/10 (-900/56; /61)</p>	<p>91-049 394-93 </p> 	<p>91-049 395-93 </p>  <p>-2/01 (-900/56; /61) -2/04 (-900/56; /61) -6/01 (-900/56; /61) -6/07 (-900/56; /61) -6/11 (-900/56; /61) -6/27 (-900/56; /61) -6/31-900/56; /61 -19/04 (-900/56; /61) -40/41 (-900/56; /61)</p>	<p>-34/01 (-900/56; /61) -34/07 (-900/56; /61)</p>
<p>91-049 402-93   </p>  <p>-40/12 (-900/56; /61)</p>	<p>91-049 434-93  </p>  <p>-2/24 (-900/56; /61)</p>	<p>91-049 483-93  </p>  <p>-17/01 -39/01 -39/21</p>	<p>91-049 490-93 </p>  <p>-40/14 (-900/56; /61)</p>
<p>91-040 533-23 </p>  <p>-17/01</p>	<p>91-041 382-23 </p>  <p>-39/21</p>	<p>91-041 969-25 </p>  <p>-39/01</p>	<p>91-046 330-93 </p>  <p>-40/01 (-900/56; /61)</p>
<p>91-053 256-93 </p>  <p>-40/05 (-900/56; /61)</p>	<p>91-053 257-93 </p>  <p>-40/41 (-900/56; /61)</p>	<p>91-053 819-93 </p>  <p>-19/04 (-900/56; /61)</p>	

Unterklassen-Übersicht/ Table of subclasses/ Table des sous-classes/ Tabla de subclases

91-156 263-90

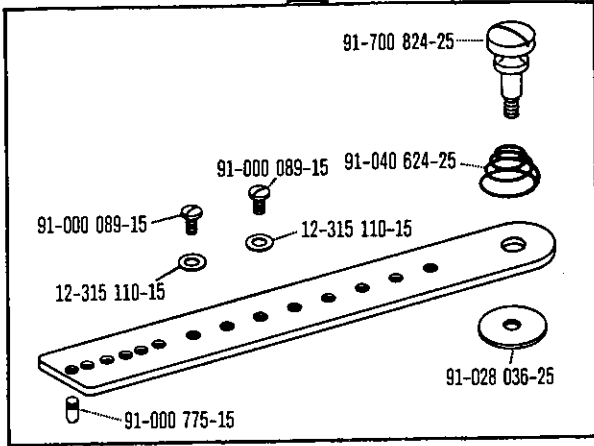

-40/01 (-900/56; /61)
 -40/05 (-900/56; /61)
 -40/41 (-900/56; /61)

91-753 936-90

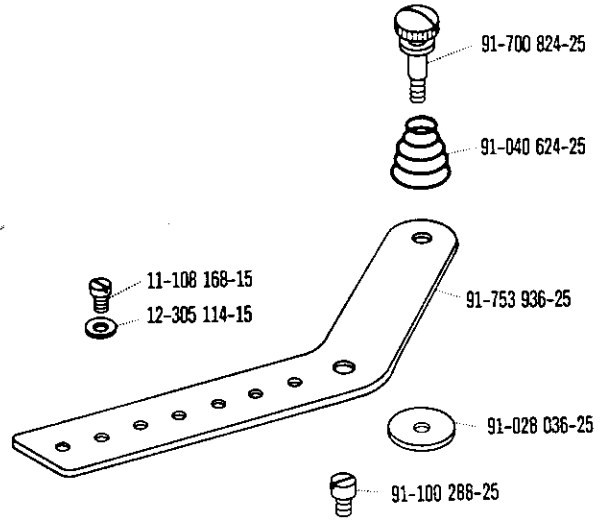

-19/04 (-900/56; /61)

91-156 269-90

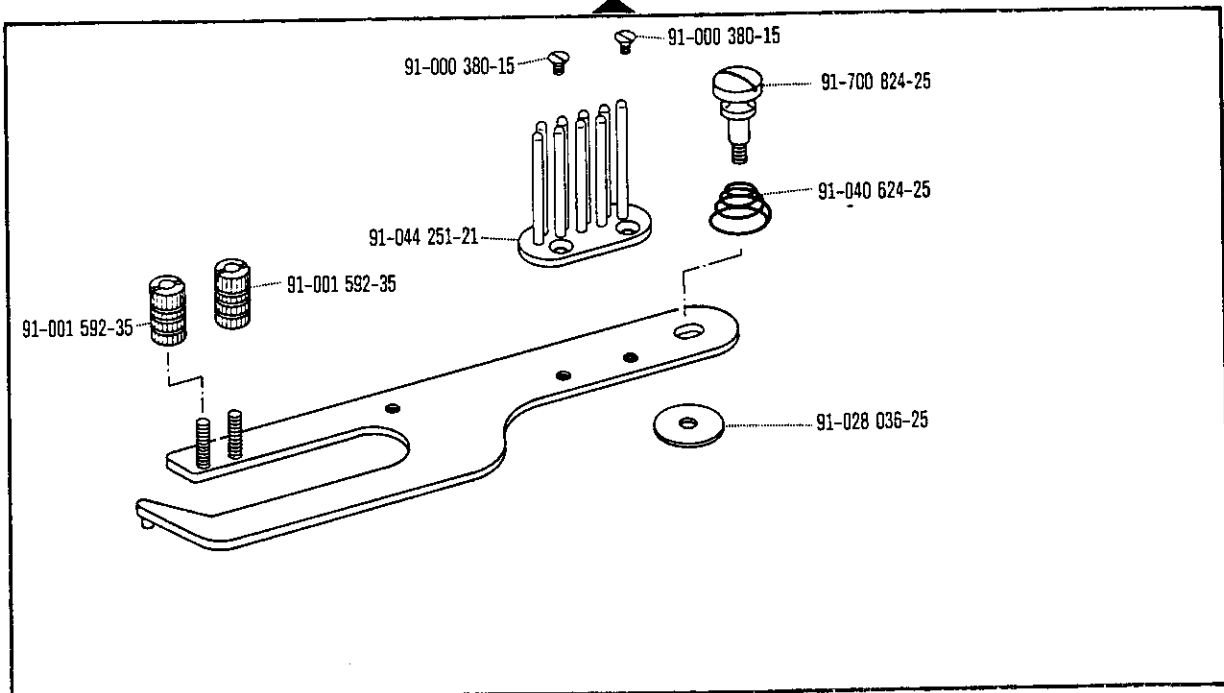

-17/01
 -39/01
 -39/21

Unterklassen-Übersicht/Table of subclasses/Table des sous-classes/Tabla de subclasses

91-053 617-91

91-173 289-25
-2/01-900/56; /61

91-700 486-25
12-305 114-15
-2/01

-2/01 (-900/56; /61)

99-117 880-23

11-132 223-15

-2/04 (-900/56; /61)
-2/24 (-900/56; /61)
-40/14 (-900/56; /61)

91-155 422-91

11-130 167-15

91-057 698-15

91-155 423-91

-6/01 (-900/56; /61)
-6/07 (-900/56; /61)
-6/11 (-900/56; /61)
-6/27 (-900/56; /61)
-6/31-900/56; /61
-19/04 (-900/56; /61)
-34/01 (-900/56; /61)
-34/07 (-900/56; /61)
-40/10 (-900/56; /61)

91-155 426-91

11-130 167-15

91-057 698-15

91-155 427-91

-2/01 (-900/56; /61)
-2/04 (-900/56; /61)
-2/24 (-900/56; /61)
-17/01
-39/01
-39/21
-40/41 (-900/56; /61)

91-155 429-91

11-130 167-15

91-057 698-15

91-155 430-91

-40/01 (-900/56; /61)
-40/05 (-900/56; /61)

91-155 433-91

11-130 167-15

91-057 698-15

91-155 434-91

-40/12 (-900/56; /61)
-40/14 (-900/56; /61)

91-155 466-91

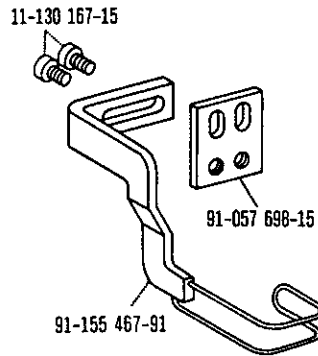

-6/01 (-900/56; /61) N10
-6/07 (-900/56; /61) N10

91-118 835-24

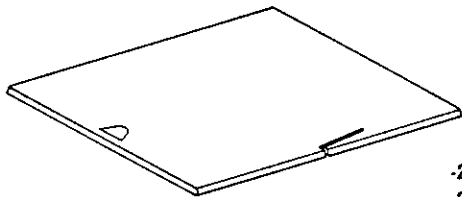

-34/01
-2/01 -34/07
-2/04 -39/01
-2/24 -39/21
-6/01 -40/01
-6/07 -40/05
-6/11 -40/10
-6/27 -40/12
-17/01 -40/14
-19/04 -40/41

91-118 844-24

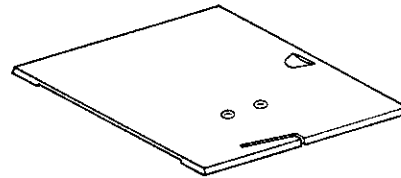

-6/27
-2/01 -19/04
-2/04 -34/01
-2/24 -34/07
-6/01 -40/10
-6/07 -40/12
-6/11 -40/14

91-173 907-24

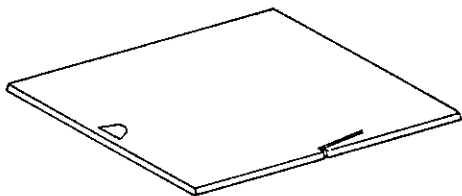

-2/01-900/56; /61 -34/01-900/56; /61
-2/04-900/56; /61 -34/07-900/56; /61
-2/24-900/56; /61 -40/01-900/56; /61
-6/01-900/56; /61 -40/05-900/56; /61
-6/07-900/56; /61 -40/10-900/56; /61
-6/11-900/56; /61 -40/12-900/56; /61
-6/27-900/56; /61 -40/14-900/56; /61
-6/31-900/56; /61 -40/41-900/56; /61

91-173 294-24

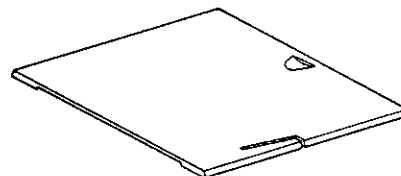

-17/01
-39/01
-39/21

Unterklassen-Übersicht/ Table of subclasses/ Table des sous-classes/ Tabla de subclasses

91-173 906-24

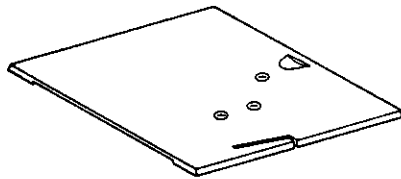

-6/27-900/56; /61
 -2/04-900/56; /61
 -2/24-900/56; /61
 -6/01-900/56; /61
 -6/07-900/56; /61
 -6/11-900/56; /61

-6/31-900/56; /61
 -19/04-900/56; /61
 -34/01-900/56; /61
 -40/14-900/56; /61
 -40/41-900/56; /61

91-173 289-25

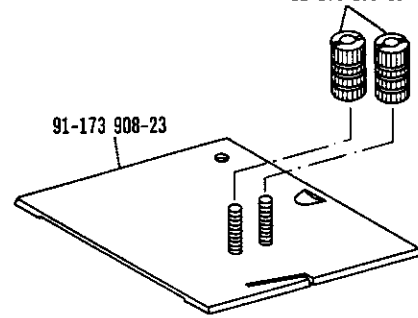

91-173 908-23

-2/01-900/56; /61

91-043 943-91

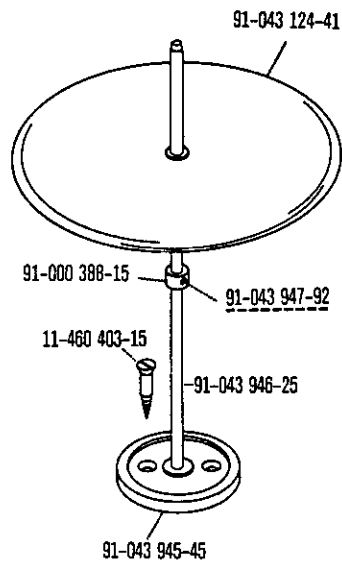

91-043 124-41

91-000 388-15

91-043 947-92

11-460 403-15

91-043 946-25

91-043 945-45

-17/01

-39/01

-39/21

Pfaff, D 6750 Kaiserslautern, Postfach 3020/3040, Telefon (0631) 200-0, Telex: 45753, Telefax (0631) 17202