

SINGER
112W130,W131,W135

1959w

INSTRUCTIONS
FOR USING AND ADJUSTING
SINGER SEWING MACHINES

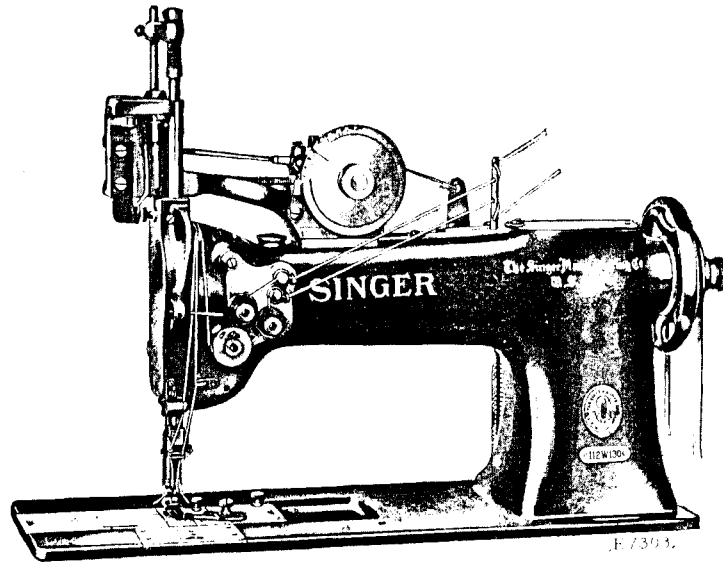

112w130, 112w131
AND 112w135

TWO NEEDLES AND TWO VERTICAL SEWING HOOKS
FITTED WITH MECHANISM FOR DISENGAGING
AND
AUTOMATICALLY RE-ENGAGING LEFT NEEDLE BAR

THE SINGER MANUFACTURING CO.

To all whom it may concern:

The placing or renewal of the name "Singer" (Reg. U. S. Pat. Off.) or any of the trade marks of The Singer Manufacturing Company on any machine that has been repaired, rebuilt, reconditioned or altered in any way whatsoever outside a Singer factory or an authorized Singer agency is forbidden.

Purchasing of Parts and Needles

Supplies of parts and needles for Singer machines can be purchased at any Singer Shop for the Manufacturing Trade or ordered by mail. If orders are sent by mail, money or a post office order covering their value, including postage, should be enclosed and the order will then be promptly filled and forwarded by mail or express.

**Genuine Singer Needles should be used
in Singer Machines.
These Needles and their Containers
are marked with the
Company's Trade Mark "SIMANCO." 1**

**Needles in Containers marked
"For Singer Machines"
are not Singer made needles. 2**

DESCRIPTION

Machine 112w130 has two needles and two vertical sewing hooks and is used for two-line lock stitching in the manufacture of collars, shirts, middy blouses and many other articles in light or medium weight fabrics where it is desired to disengage the left needle bar when turning square or triangular corners to avoid crossing the line of stitching.

At a distance from the corner equal to the gauge of the machine, the left needle bar is released from its driving mechanism by pressure on a treadle; the right hand needle then stitches alone to the corner and an equal distance beyond it after turning, when the left needle is automatically returned into action and the two-line stitching is resumed.

A dial is located at the top of the machine by means of which the number of stitches omitted by the left needle can be varied according to the description of corner to be sewn.

The distance between the two needles may be from $\frac{1}{8}$ to $\frac{3}{8}$ inch, as desired, and orders for the machine must specify the gauge required.

The machine has a drop feed and knee lifter for raising the presser foot.

Machine 112w131 is similar to Machine 112w130 and is intended for use where a wide gauge is required. The distance between the two needles may be from $\frac{1}{4}$ to 1 inch, as ordered.

Machine 112 w 135 is similar to Machine 112 w 130 and is intended for use in the manufacture of shoes and other articles made from light and medium weight leather. The distance between the two needles may be from $\frac{3}{8}$ to $\frac{1}{2}$ inch, as ordered. The machine has a ball bearing roller presser.

Speed

The maximum speed recommended for Machines 112 w 130, 112 w 131 and 112 w 135 is 2500 per minute. The machines should be run slower than the maximum speed until the parts which are in movable contact have become glazed by their action upon each other. When the machines are in operation the balance wheel should always turn over toward the operator.

Needles

Needles for Machines 112 w 130 and 112 w 131 are of Class and Variety 135 x 7, and are made in sizes Nos. 9, 10, 12, 14, 16, 18, 20 and 22.

Needles for Machine 112 w 135 are of Class and Variety 128 x 20, and are made in sizes Nos. 9, 10, 11, 12, 13, 14, 15, 16, 18, 20, 22 and 23.

The size of the needle to be used should be determined by the size of the thread which must pass freely through the eye of the needle. If rough or uneven thread is used or if it passes with difficulty through the eye of the needle, the successful use of the machine will be interfered with.

Orders for needles must specify the quantity required, the size number, also the class and variety numbers separated by the letter x.

The following is an example of an intelligible order:

"100 No. 16, 135 x 7 Needles," (for Machines 112 w 130 and 112 w 131).

"100 No. 14, 128 x 20 Needles," (for Machine 112 w 135).

The best results will be obtained in using the needles furnished by the Singer Sewing Machine Company.

Thread

Use left twist thread for both needles. Either left or right twist thread may be used for the bobbins.

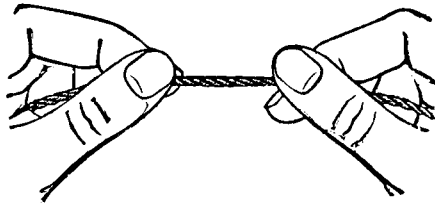

Fig. 2. How to Determine the Twist

Hold the thread as shown above. Turn the thread over toward you between the thumb and the forefinger of the right hand; if left twist, the strands will wind tighter; if right twist, the strands will unwind.

The Relative Sizes of Needles and Thread

The following sizes of needles and thread are recommended:

SIZES OF NEEDLES	COTTON	SILK
9	150	000
10, 11	90, 100	000, 00
12, 13	70, 80	00, 0
14, 15	60, 70	0, A
16	40 to 60	A, B
18	30 to 40	B, C
20	24, 30	D, E
22	16, 24	E

To Set the Needles

Turn the balance wheel over toward you until the needle bar moves up to its highest point; loosen the set screws in the needle holder and put the needles up into the holder as far as they will go, the inside needle or the one nearest the upright part of the arm having its long groove toward the left, and the outside needle or the one farthest from the upright part of the arm having its long groove toward the right, the eyes of both needles being directly in line with the machine bed, then tighten the set screws.

To Remove the Bobbins

Draw out the slide plates in the bed of the machine. Turn the balance wheel over toward you until the needle bar moves up to its highest point. Place the thumb or finger under the projection on the side of the bobbin case cap, as shown in Fig. 3, then lift out the cap and remove the bobbin.

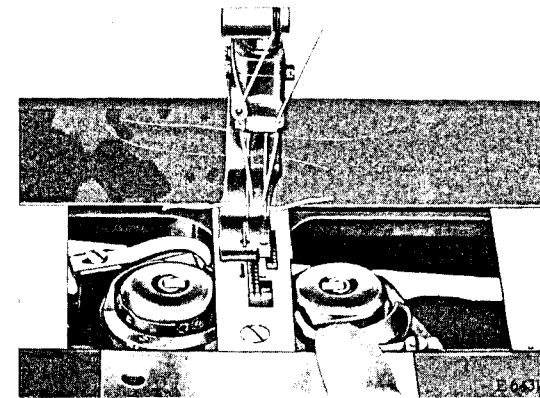

Fig. 3. Removing the Bobbin

To Wind the Bobbin

(See Fig. 4)

Fasten the bobbin winder to the table with its driving pulley in front of the machine belt, so that the pulley will drop away from the belt when sufficient thread has been wound upon the bobbin.

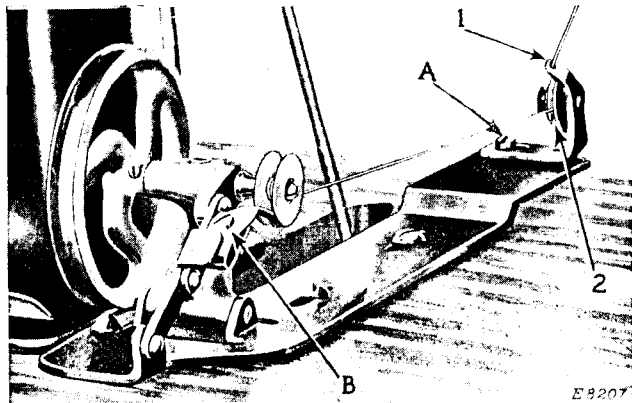

Fig. 4. Winding the Bobbin

Place the bobbin on the bobbin winder spindle and push it on as far as it will go.

Pass the thread down through the thread guide (1) in the tension bracket, around the back and between the tension discs (2). Then wind the end of the thread around the bobbin a few times, push the bobbin winder pulley over against the machine belt and start the machine.

When sufficient thread has been wound upon the bobbin, the bobbin winder will stop automatically.

If the thread does not wind evenly on the bobbin, loosen the screw (A) in the tension bracket and move the bracket to the right or left as may be required, then tighten the screw.

The amount of thread wound on the bobbin is regulated by the screw (B). To wind more thread on the bobbin, turn the screw (B) inwardly. To wind less thread on the bobbin, turn the screw outwardly.

Bobbins can be wound while the machine is stitching.

To Thread the Bobbin Case Caps

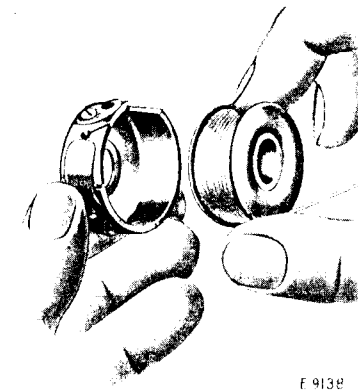

Fig. 5

Hold the bobbin between the thumb and forefinger of the right hand, the thread drawing on bottom from the left toward the right, as shown in Fig. 5.

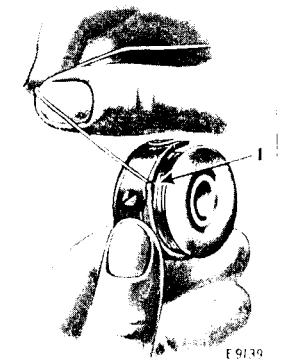

Fig. 6

With the left hand hold the bobbin case cap as shown in Fig. 5, and place the bobbin into it.

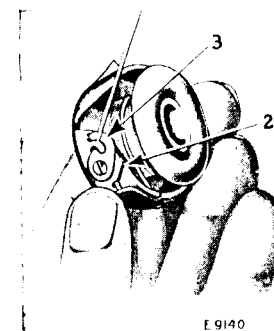

Fig. 7

Then pull the thread into the slot (1, Fig. 6) in the edge of the bobbin case cap and under the tension spring, through the slot (2, Fig. 7) and out under the thread guide 3, as shown in Fig. 7.

To ensure the correct tension, draw the thread under the tension spring once or twice; this will remove any lint which may become lodged under the spring.

top of the machine, then up and from right to left through the hole (B) in the pin, into the wire thread guide (C) at the right of the lower thread retainer, through the lower thread retainer (D), under from right to left between the right tension discs (E), down under from right to left around the thread controller (F), into the thread controller spring (G) and up through the thread guide (H), up and from right to left through the lower hole (J) in the end of the thread take-up lever, down through the thread guide (K) and through the thread guide (L), down through the right hole (M) in the needle holder and from left to right through the eye of the right or inside needle (N).

To Thread the Needles in Machine 112 w 135

Pass the threads from the unwinder through the two centre holes in the right hand side of the thread oiler which is attached to the pin on top of the machine, pull end of thread holding wire toward you until the short end is disengaged from body of the thread oiler, turn to the right until wire inside of oiler is raised to highest point above the felt, then pass threads under the wire and under the tension oil pad and through the two centre notches in left side of thread oiler. Turn the thread holding wire to the left until the short end is in its first position. Then pass the threads through the thread guides (3 and C, Fig. 9). The rest of the threading is the same as instructed for Machine 112 w 130 on pages 8, 9 and above.

Roller Presser, Machine 112 w 135

For convenience in threading, press down on the roller and swing it out to the left.

To Prepare for Sewing

With the left hand hold the ends of the needle threads, leaving them slack from the hand to the needles. Turn the balance wheel over toward you until the needles move down and up again to their highest point, thus catching the bobbin threads; draw up the needle threads and the bobbin threads will come up with them through the holes in the throat plate. Lay the threads back under the presser foot or roller presser and close the slides.

To Commence Sewing

Place the material beneath the presser foot or roller presser, lower the presser bar and commence to sew, turning the balance wheel over toward you.

Instructions for Making Corners

The needle bar locking pin (F2, Fig. 10) can be disengaged to throw the left needle bar out of action only when the needle bar is at its highest point. This ensures the number of stitches omitted by the left needle corresponding accurately with the number on the index dial (O2, Fig. 10) to which the adjusting dial (P2, Fig. 10) is set.

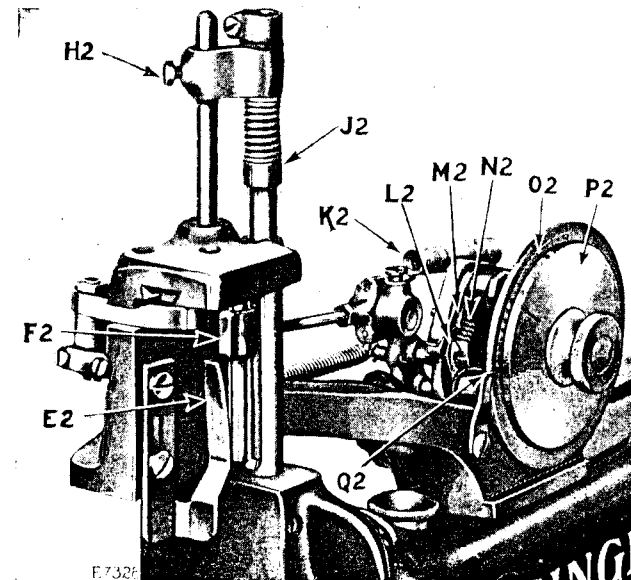

Fig. 10. Adjustments of Mechanism for Disengaging and Engaging Left Needle Bar

To disengage the locking pin (F2), press down on the foot lever and turn the balance wheel until the needle bar is at its highest point, when the locking pin (F2) will be disengaged by the action of the spring (K2, Fig. 10), then release the pressure on the foot lever. The locking pin (F2) will be held in this position by the retaining spring as shown at E2 in Fig. 11, until it is automatically re-engaged.

Figure 10 shows the left needle bar locked in position for making the two-line stitching. The ratchet pawls (L2 and M2) are held in position away from the ratchet wheel (N2), while the pointer (Q2) registers with No. 1 on the index dial (O2).

When making a square or triangular corner and the needle bar locking pin (F2) is disengaged as shown in Fig. 11, the ratchet

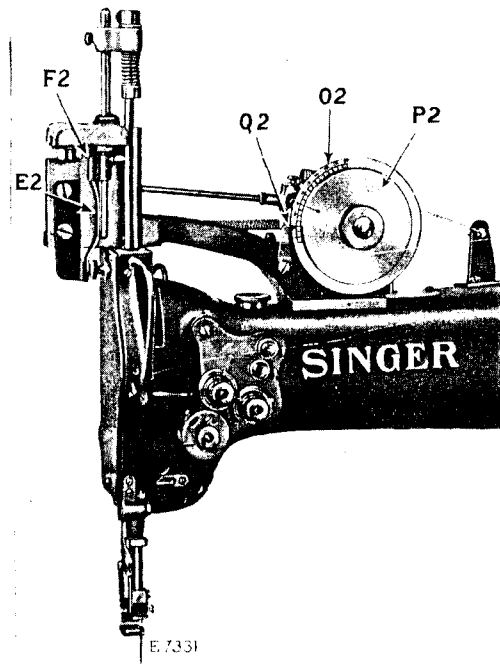

Fig. 11. Showing Left Needle Bar Out of Action with Locking Pin (F2) Disengaged

pawls (L2 and M2, Fig. 10) are brought into contact with the ratchet wheel (N2, Fig. 10) and the index dial (O2, Fig. 10) rotates in unison with the ratchet wheel, indicating the number of stitches which have been omitted by the left hand needle at the point when the right needle is in the goods. For example, when making a square corner with a $\frac{1}{4}$ inch gauge machine, sewing 16 stitches to the inch, it will be necessary for the left hand needle to omit eight stitches; four stitches before reaching the corner and four stitches after leaving the corner. In this case, set the adjusting dial (P2, Fig. 10) so that the zero mark on its face registers with No. 8 on the index dial (O2) as shown in Fig. 11. When the needles are four stitches from the corner,

press down on the foot lever until the locking pin (F2) is disengaged, then allow the foot lever to return to its highest point and sew straight ahead with the right hand needle until the pointer (Q2, Fig. 10) registers with No. 4 on the index dial (O2) with the needle in the goods, as shown in Fig. 11. Raise the presser foot or roller presser, make the square turn with the goods, then sew at slow speed until the left needle is automatically re-engaged on the eighth stitch, then proceed with the two-line stitching.

Edge Guide complete 236793 can be used to advantage when making corners on collars, by adjusting the point of edge guide 236791 to same distance in front of needles as the corner of the collar should be when in the proper position to have the left needle thrown out of action before turning the corner. The operator will then sew along the edge of the collar, throwing the needle out of action when the point of the collar reaches the point of the edge guide, then sew to the corner of the collar, turn material and proceed with seam.

CAUTION. Care must be taken to press the foot lever only when it is desired to disengage the needle bar locking pin (F2, Fig. 10). Continued pressure on the foot lever will cause the left needle to omit more stitches than the index dial is set for and at the same time will prevent the locking pin (F2) from re-engaging the needle bars for the two-needle stitching.

Retaining Spring No. 236843

Retaining spring 236843 will be furnished, on order, at an additional charge, for use when the class of work being sewn does not require accuracy in the number of stitches omitted by the left needle at the corner. This spring can be installed in place of the regular retaining spring 236842 (E2, Fig. 10) and its use permits the locking pin (F2, Fig. 10) to be disengaged at any part of the stroke of the needle bar.

To Adjust the Needle Bar Position Stop

The needle bar position stop (J2, Fig. 10) should be directly over the top of the needle bar and set at a height which will permit the stop to be lightly touched by the needle bar when the needle bar is at its highest point. This will ensure the left needle bar being in the correct position when the locking pin (F2, Fig. 10) is re-engaged after making a corner.

To change the height of the needle bar position stop (J2), loosen the screw (H2, Fig. 10) and move the needle bar position stop bracket up or down, as required, after which securely tighten the screw (H2).

Safety Latch

The machine is fitted with the safety latch (U2, Fig. 12) which is a part of the tripping lever (T2, Fig. 12). When the tripping

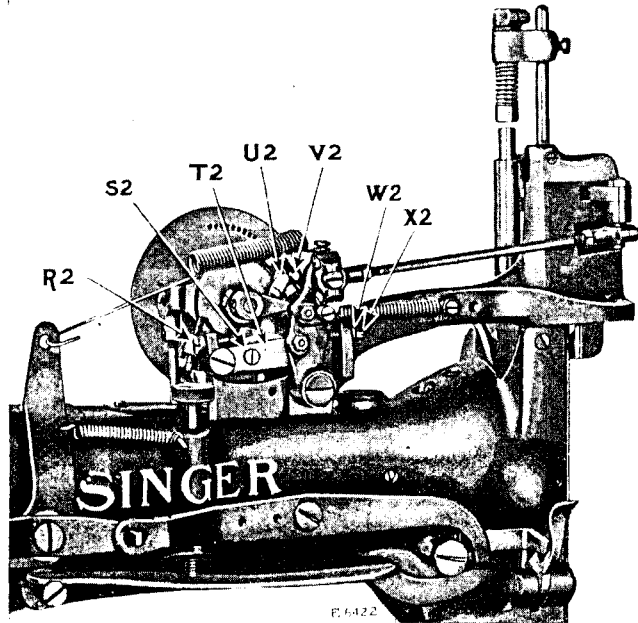

Fig. 12. Showing Safety Latch
Also Adjustments on the Machine

lever (T2) is fully released, the safety latch (U2) is moved to a position close to the safety stud (V2, Fig. 12) in the upper ratchet pawl (M2, Fig. 10) so that the pawl, on its reverse movement, will be raised out of the ratchet teeth, thus preventing the index dial (O2, Fig. 10) from moving beyond the number for which it is set. This safety latch also prevents the machine from being damaged should the operator hold the foot lever down too long.

To Time Tripping Lever with Index Dial

To time the tripping lever (T2, Fig. 12) so that the locking pin (F2, Fig. 10) will lock the two needle bars together in correct time with the index dial, loosen the binding screw (S2, Fig. 12) and turn the adjusting screw (R2, Fig. 12) to the left to make it trip earlier or to the right to make it trip later. The tripping lever (T2) should be timed to trip when the needle bar is on its upward stroke and should be fully released when the needle bar is within $\frac{1}{16}$ to $\frac{3}{32}$ inch of the top of its upward stroke. When the tripping lever is correctly timed with the index dial, securely tighten the binding screw (S2).

Adjustment to Prevent Friction Pressure on Needle Bar Bushing

Adjusting screw (X2, Fig. 12) is set to prevent pressure of the end of the locking pin (F2, Fig. 10) against the inside of the needle bar bushing to prevent friction on the needle bar bushing.

To adjust screw (X2), loosen the check nut (W2, Fig. 12) and turn the adjusting screw to the right to move the locking pin away from the needle bar bushing or turn the screw to the left to move the locking pin toward the needle bar bushing, then tighten the check nut (W2).

To Remove the Work

Let the thread take-up lever rest at its highest point, raise the presser foot or roller presser, draw the work back and cut the threads close to the goods. Lay the ends of the threads back under the presser foot or roller presser.

Tensions

The needle and bobbin threads should be locked in the centre of the thickness of the material, thus:



Fig. 13. Perfect Stitch

If the tension on the needle thread is too tight, or if that on the bobbin thread is too loose, the needle thread will lie straight along the upper surface of the material, thus:



Fig. 14. Tight Needle Thread Tension

If the tension on the bobbin thread is too tight, or if that on the needle thread is too loose, the bobbin thread will lie straight along the under side of the material, thus:



Fig. 15. Loose Needle Thread Tension

To Regulate the Tensions

The tensions on the needle threads are regulated by the two thumb nuts (E3, Fig. 21, page 21) at the front of the tension discs on the front of the machine. To increase the tension, turn these thumb nuts over to the right. To decrease the tension, turn the thumb nuts over to the left.

The tensions on the bobbin threads are regulated by means of the screw nearest the centre of the tension spring on the outside of each bobbin case cap. To increase the tension, turn this screw over to the right. To decrease the tension, turn the screw over to the left.

To Regulate the Length of Stitch

The length of stitch is regulated by the thumb screw (A, Fig. 16) at the right of the balance wheel.

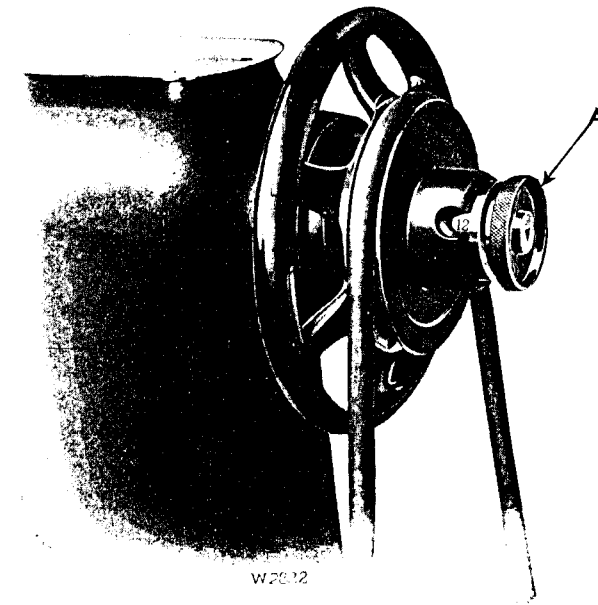

Fig. 16. Stitch Regulator

There is a notch in the hub of the balance wheel as shown in Fig. 16 and the number appearing in the notch shows the number of stitches to the inch that the machine is ready to make.

To lengthen the stitch, turn the thumb screw (A) over toward you. To shorten the stitch, turn this thumb screw over from you.

To Regulate the Pressure on Material

The pressure on the material is regulated by the thumb screw (Z2, Fig. 20, page 19), at the back of the machine, the thumb screw acting on a flat spring. To increase the pressure, turn the thumb screw (Z2) downwardly. To decrease the pressure, turn this thumb screw upwardly. The pressure should be only heavy enough to enable the feed to move the work along evenly.

Roller Presser, Machine 112 w 135

The roller should be set close enough to the needle to steady it and prevent it from staggering, and far enough back to prevent the leather from stretching.

To Oil the Machine

To ensure easy running and prevent unnecessary wear of the parts which are in movable contact, the machine requires oiling, and when in continuous use, it should be oiled at least twice each day.

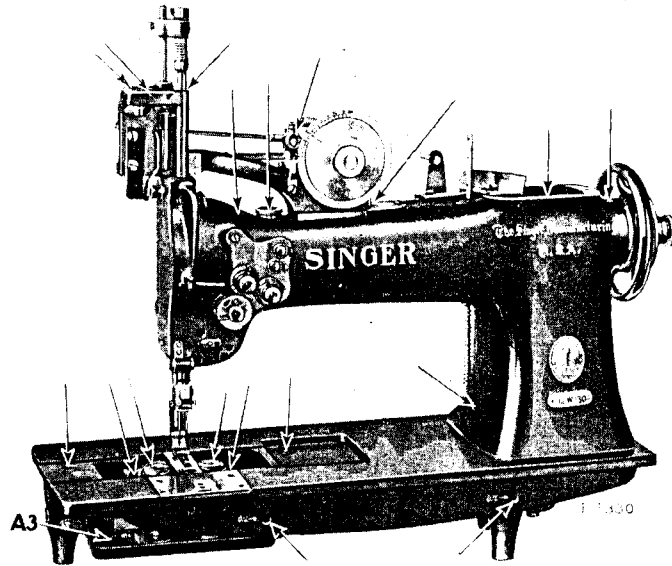

Fig. 17. Oiling Points at the Front of the Machine

Oil should be applied at the places designated by arrows as shown in Figs. 17, 18, 19 and 20. Swing back the cover which is on the top of the machine at the right, and oil the bearings which are thus uncovered, then replace the cover.

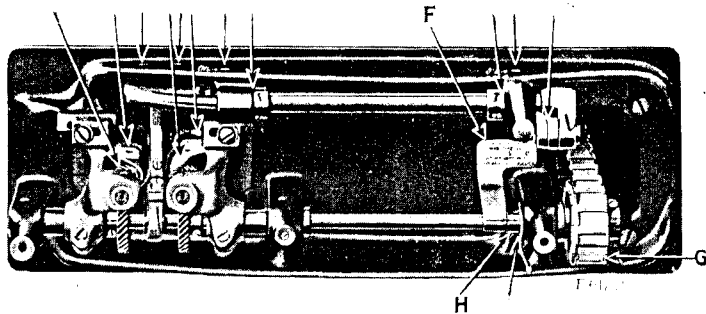

Fig. 18. Base of Machine, Showing Oiling Points

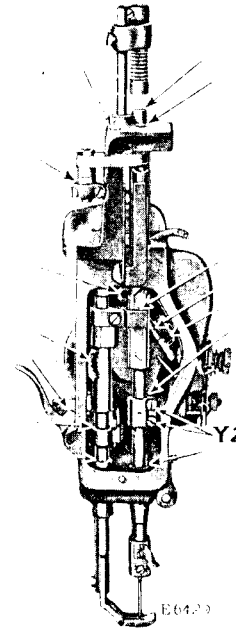

Fig. 19. End View of Machine, Showing Oiling Points

Turn the machine back on its hinges and apply oil at the places designated by arrows as shown in Fig. 18, and all other places where there are parts in movable contact, then bring the machine forward into place.

Pour sufficient oil into the oil pan (A3, Fig. 20) to saturate the oil pad therein.

Oil the bobbin case bearings in the bobbin case races each time a bobbin is replaced.

Loosen the thumb screw in the upper end of the face plate, pull out the lower end of the face plate over the position pin, then pull down the face plate to remove it, oil the wick and bearings which are thus uncovered, then replace the face plate and fasten it in position with the thumb screw.

On Machine 112w135, occasionally apply oil to the oil hole in the ball bearing roller presser.

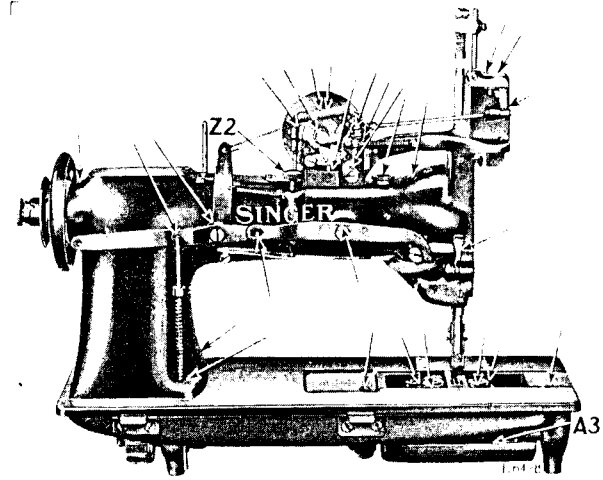

Fig. 20. Oiling Points at the Back of the Machine

INSTRUCTIONS

FOR

ADJUSTERS AND MACHINISTS

Thread Controller

The function of the thread controller spring is to hold back the slack of the needle threads until the eye of each needle reaches the goods in its descent, as without this controlling action of the spring, the slack thread or silk (more especially silk) will sometimes be penetrated by the point of the needle as the needle is descending.

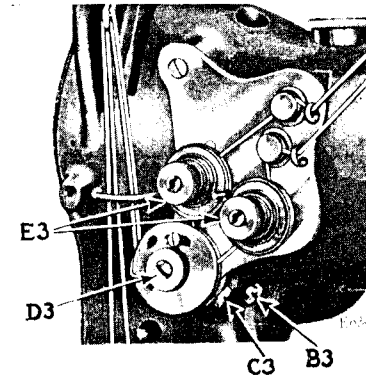

Fig. 21. Adjustment of Thread Controller

To change the thread controller stop for more controller action on the threads, loosen the set screw (C3, Fig. 21) and turn the thread controller spring stop to the right; for less action, turn the thread controller spring stop to the left, after which securely tighten the set screw (C3).

It may be found advisable to increase the tension of the spring for coarse thread, or to lessen it for fine thread.

To increase the tension of the thread controller on the threads, loosen the tension stud set screw (B3, Fig. 21), located nearly under the tension stud, and turn the tension stud (D3, Fig. 21) slightly to the left with a screwdriver, or to decrease the tension, turn it to the right and retighten the stud set screw (B3).

To Set the Needle Bar

See that the needles are up in the bar as far as they will go. There are two lines across the needle bar about two inches above the lower end. When the needle bar is at its lowest position, the upper mark should be just visible at the bottom of the needle bar bushing.

In case the needle bar is not correctly timed, loosen the needle bar connecting stud pinch screws (Y2, Fig. 19) and place the needle bar in the correct position as directed above, then retighten the screws (Y2).

To Set a Needle Bar which has no Mark. Set the stitch regulator to indicate 8 stitches to the inch, then set the needle bar so that when it rises $\frac{3}{8}$ inch from its lowest position, the points of the sewing hooks will be at the centre of the needles and about $\frac{1}{16}$ inch above the eye.

To Time the Sewing Hooks

Set the feed regulator spindle head to indicate eight stitches to the inch.

Remove the throat plate and turn the balance wheel over toward you until the lower mark across the needle bar is just visible at the bottom of the needle bar bushing on the upward stroke of the needle bar. If the needle bar and sewing hooks are correctly timed, the point of each hook will be at the centre of its needle and about $\frac{1}{16}$ inch above the eye.

In case the sewing hooks are not correctly timed, turn balance wheel over toward you until needle bar has descended to its lowest point and has risen until the lower timing mark across the needle bar is just visible at the bottom of the needle bar bushing. Then loosen the four screws (T, Fig. 22) in the hook shaft gears and turn the sewing hooks until the point of each hook is at the centre of its needle, after which securely tighten the four screws (T), leaving just enough end play to the shaft for lubricating purposes.

To Set the Sewing Hooks to or from the Needles

To prevent the points of the hooks from dividing the strands of the threads, they should run as close to the needles (within the scarf) as possible.

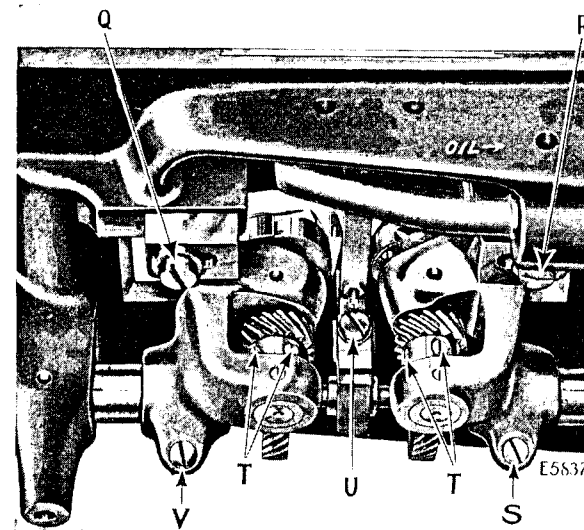

Fig. 22. Adjustment of Hook Saddles

Turn the balance wheel over toward you until the points of the sewing hooks are at the centre of the needles. Loosen the four screws (Q, R, S and V, Fig. 22) underneath the bed of the machine and move the hook saddles to the right or left, as may be required, until the points of the hooks are as close to the needles as possible without striking them, then securely tighten the four screws (Q, R, S and V).

The needle guard washer (AA, Fig. 24) which is attached to the bottom of each sewing hook, should be sprung until it prevents the needles from striking the hooks in case the needles are deflected towards the hooks.

To Remove the Bobbin Case Bases from the Sewing Hooks

Remove the four hook gib screws (X, Fig. 23) from the sewing hooks, lift off the hook gibs (Z, Fig. 24) and remove the bobbin case bases (Y, Fig. 23).

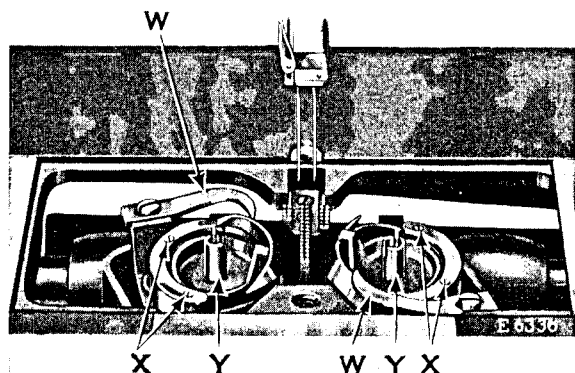

Fig. 23. Removing Bobbin Case Bases

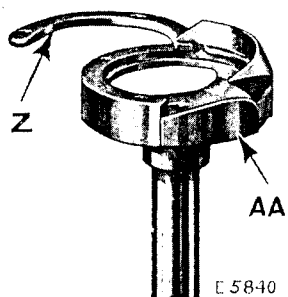

Fig. 24. Sewing Hook Removed from Machine Showing Hook Washer

To Remove the Sewing Hooks from the Machine

Remove the throat plate, feed dog and the two bobbin case opening levers (W, Fig. 23). Also remove the bobbin case bases as instructed above, then take out the four screws (T, Fig. 22) from the hook shaft gears and lift out the sewing hooks.

To Change Gauge of Machine 112 w 135



Fig. 25

Shim $\frac{1}{8}$ inch thick No. 229744

Shim $\frac{1}{16}$ inch thick No. 229745

Shim $\frac{1}{32}$ inch thick No. 202760

In order to change the roller presser from one gauge or width between needles to another, use a needle guard, throat plate and feed dog of the width desired and one or more shims to set the roller outward. A $\frac{1}{16}$ inch shim sets the roller properly for $\frac{1}{8}$ inch gauge.

Adjustment of Feed Regulating Spindle Head

The figures on the feed regulating spindle head (DD, Fig. 26), showing through the notch in the balance wheel, indicate the

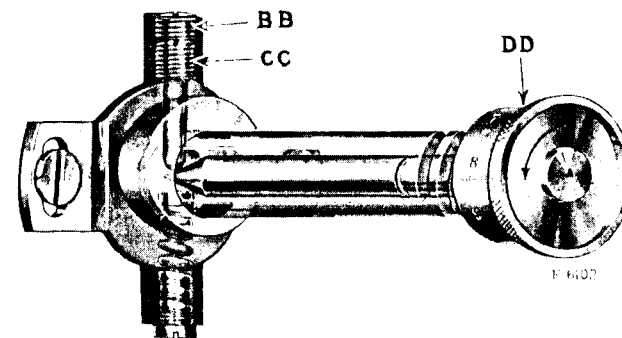

Fig. 26. "X-Ray" View of Feed Driving Eccentric Regulating Bracket and Shaft Showing the Feed Regulating Spindle and Adjusting Screw (CC) Which Comes in Contact with the Cone of the Spindle to Gauge the Length of Stitch

number of stitches to the inch which should be made. If more or less stitches are made, adjust as follows: Remove screw (BB, Fig. 26), set the indicator at 8 and the feed dog at its highest point, a full tooth showing above the throat plate, then adjust screw (CC, Fig. 26) until eight stitches to the inch is the result and replace check screw (BB) firmly.

By making this adjustment with the stitch indicator set at 8 stitches, the full range of the stitch regulator is automatically taken care of so that the number appearing in the notch in the balance wheel will always indicate the correct number of stitches to the inch that the machine is ready to make.

To Set the Feed Regulator so that a Stitch Longer Than the One Desired cannot be Made. Turn the spindle head (DD, Fig. 26) as far as possible in the direction indicated by the arrow in Fig. 26; remove the check screw (BB) and turn screw (CC) down until the machine makes the desired number of stitches to the inch, then turn screw (BB) down tightly on screw (CC) as a check. The stitch may be then changed by turning the stitch regulator (DD) for shorter stitches, but operators cannot make a longer stitch than that limited by the above adjustment.

To Raise or Lower the Feed Dog

Usually when the feed dog is at its highest position, it should show a full tooth above the throat plate.

Remove the throat plate; clean the lint and dust from between the feed points and replace the throat plate; tip the machine back and turn the balance wheel towards you until the feed dog is at its highest position; loosen screw (U, Fig. 22, page 23) in the feed lifting cam fork and raise or lower the feed dog, as may be required, and retighten the screw (U).

When raising or lowering the feed dog, be careful that its under side does not drop low enough to strike the sewing hooks.

To Remove the Arm Shaft Connection Belt from Within the Arm

Slide the connection belt off lower pulley (G, Fig. 18, page 18); remove the feed regulating spindle head and balance wheel; remove the arm shaft bushing (back) screws and remove the bushing; lift the belt up through the arm cap hole as far as possible and draw it out through the space normally occupied by the bushing.

Owing to the fact that the sewing hooks make two revolutions to one revolution of the arm shaft, and that the feed lifting eccentric is on the hook shaft, it is possible to have the sewing hooks correctly timed without having the feed eccentric correctly timed. To overcome this, the plate (F, Fig. 18) is attached to the under side of the bed of the machine. This plate is marked with an arrow at its lower end and directly alongside of the plate is the collar (II, Fig. 18) mounted on the hook shaft, which is also marked with an arrow. When replacing the belt, replace the arm shaft bushing and securely fasten it in position by the screws; replace the feed regulating spindle head and the balance wheel, and place the belt on the upper pulley, and then turn the balance wheel over toward you until the thread take-up lever is at its highest point. Then turn the hook shaft with the fingers until the two arrows, one on plate "F" and the other on collar "II", are directly in line. Now, without disturbing either the arm shaft or the hook shaft, slip the belt over the lower pulley (G, Fig. 18). The feed will then be correctly timed with the needle bar.

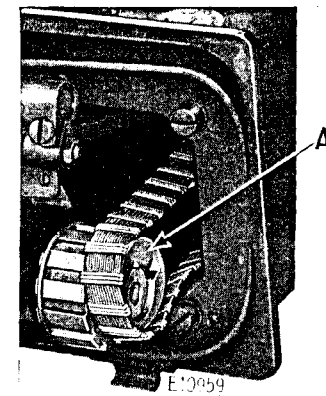

Fig. 27. Putting Belt on Lower Pulley with Belt Replacer 241538

To facilitate the replacing of the belt on the lower pulley, use belt replacer No. 241538 (A, Fig. 27). Rest the replacer in the loop of the belt as shown in Fig. 27, having the notches in the replacer engage the two set screws in the hub of the pulley. Turn the balance wheel toward you until the belt is fully over the pulley, then remove the replacer.

Note: As belt replacer No. 241538 will serve for several machines, it is not regularly furnished with the machine, and must be ordered separately.