

SINGER
118W4

USE ONLY **SINGER** OILS and LUBRICANTS

*They insure freedom from lubricating trouble and
give longer life to sewing equipment*

The following are the correct lubricants for this machine:

TYPE B—MANUFACTURING MACHINE OIL, HEAVY GRADE

When a stainless oil is desired, use:

TYPE D—MANUFACTURING MACHINE OIL, STAINLESS,
HEAVY GRADE

GEAR LUBRICANT

This specially prepared grease is recommended for gear
lubrication on manufacturing sewing machines.

OTHER **SINGER** LUBRICANTS

TYPE E—THREAD LUBRICANT

For lubricating the needle thread of sewing machines for
stitching fabrics or leather where a thread lubricant is
required.

TYPE F—MOTOR OIL

For oil lubricated motors and plain bearings in power
tables and transmitters.

NOTE: All of the above oils are available in 1 quart,
1 gallon and 5 gallon cans or in 55 gallon drums.

BALL BEARING LUBRICANT

This pure grease is specially designed for the lubrication
of ball bearings and ball thrust bearings of motors and
electric transmitters, ball bearing hangers of power tables,
etc. Furnished in 1 lb. and 4 lb. tins.

INSTRUCTIONS FOR USING **SINGER*** SEWING MACHINE

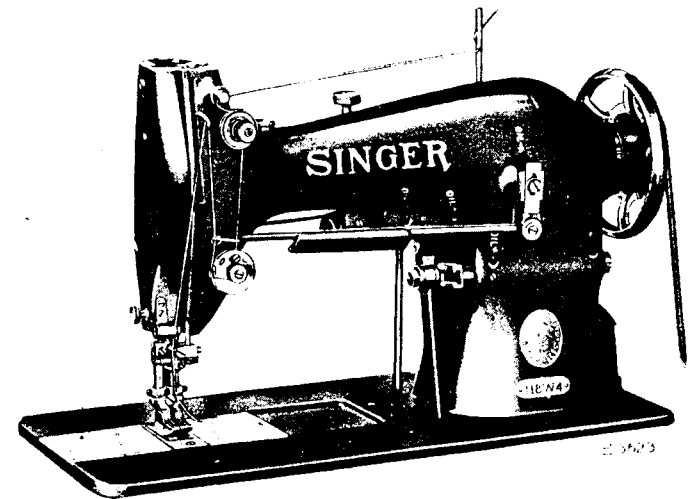

118w4

(ONE NEEDLE)

HIGH SPEED

HEMSTITCH

*A TRADE MARK OF
THE SINGER MANUFACTURING COMPANY

TO ALL WHOM IT MAY CONCERN:

The improper placing or renewal of the Trade Mark "**SINGER**" or any other of the Trade Marks of The Singer Manufacturing Company (all of which are duly Registered Trade Marks) on any machine that has been repaired, rebuilt, reconditioned, or altered in any way whatsoever outside a **SINGER** factory or an authorized **SINGER** agency is forbidden.

THE IMPORTANCE OF USING **SINGER*** PARTS AND NEEDLES IN **SINGER** MACHINES

The successful operation of **SINGER** machines can only be assured if **SINGER** parts and needles are used. Supplies are available at all **SINGER** Shops for the Manufacturing Trade, and mail orders will receive prompt attention.

SINGER Needles should be used
in **SINGER** Machines
These Needles and their Containers
are marked with the
Company's Trade Mark "**SIMANCO.***" 1

Needles in Containers marked
"**FOR SINGER MACHINES**"
are **NOT SINGER** made needles. 2

Copyright, U. S. A., 1914, 1919, 1921, 1929, 1934 and 1940
by The Singer Manufacturing Company
All Rights Reserved for all Countries

DESCRIPTION

Machine 118 w 4 is designed for hemstitching at high speed, and is largely used in the manufacture of handkerchiefs, shirt waists, neckties, infants' wear, and many other articles of light weight fabrics. It has one needle and a rotary hook, and can be fitted with one or two piercers, as desired.

Speed

The maximum speed recommended for Machine No. 118w4 is 2800 stitches per minute. The machine should be run slower than the maximum speed until the parts which are in movable contact have become glazed by their action upon each other.

When the machine is in operation the balance wheel should always turn over toward the operator.

Needles

Needles for Machine 118 w 4 are of Class and Variety 128 x 15 and are furnished in sizes Nos. 12 and 14.

The size of the needle to be used should be determined by the size of the thread, which must pass freely through the eye of the needle. If rough or uneven thread is used, or if it passes with difficulty through the eye of the needle, the successful use of the machine will be interfered with.

Orders for needles must specify the **quantity** required, the **size** number, also the **class** and **variety** numbers separated by x.

The following is an example of an intelligible order:

"100 No. 14, 128x15 Needles."

The best results will be obtained in using the needles sold by Singer Sewing Machine Company.

Thread

Left twist thread should be used in the needle. Either right or left twist can be used in the bobbin.

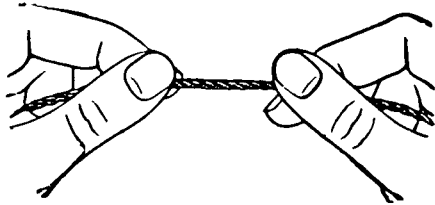

Fig. 2. How to Determine the Twist

Hold the thread as shown above. Turn the thread over toward you between the thumb and forefinger of the right hand; if left twist, the strands will wind tighter; if right twist, the strands will unwind.

Fine thread should always be used. Sizes .100 to 160 cotton thread are recommended.

To Remove the Bobbin

Draw out the right hand slide in the bed of the machine. Turn the balance wheel over toward you by hand until the needle

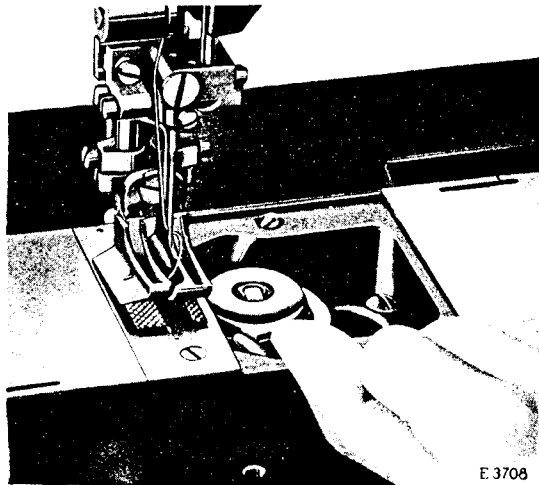

Fig. 3. Removing the Bobbin

bar moves up to its highest point. Place the thumb nail under the projection on the side of the bobbin case cap, as shown in Fig. 3, then lift out the cap and remove the bobbin.

To Wind the Bobbin

(See Fig. 4)

Fasten the bobbin winder to the table with its driving pulley in front of the machine belt so that the pulley will drop away from the belt when sufficient thread has been wound upon the bobbin.

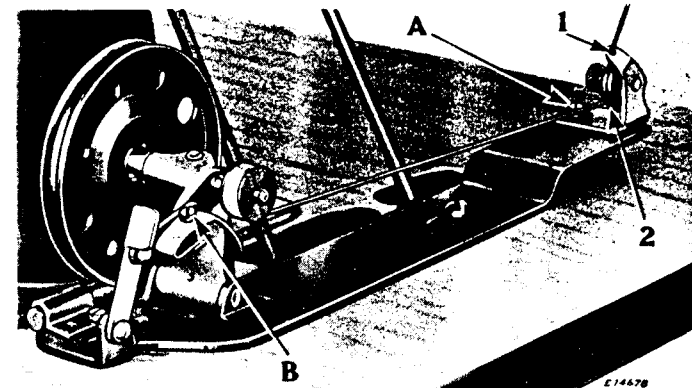

Fig. 4. Winding the Bobbin

Place the bobbin on the bobbin winder spindle and push it on as far as it will go.

Pass the thread down through the thread guide (1) in the tension bracket, around the back and between the tension discs (2). Then wind the end of the thread around the bobbin a few times, push the bobbin winder pulley over against the machine belt and start the machine.

When sufficient thread has been wound upon the bobbin, the bobbin winder will stop automatically.

If the thread does not wind evenly on the bobbin, loosen the screw (A) in the tension bracket and move the bracket to the right or left as may be required, then tighten the screw.

The amount of thread wound on the bobbin is regulated by the screw (B). To wind more thread on the bobbin, turn the screw (B) inwardly. To wind less thread on the bobbin, turn the screw outwardly.

Bobbins can be wound while the machine is stitching.

To Thread the Bobbin Case Cap

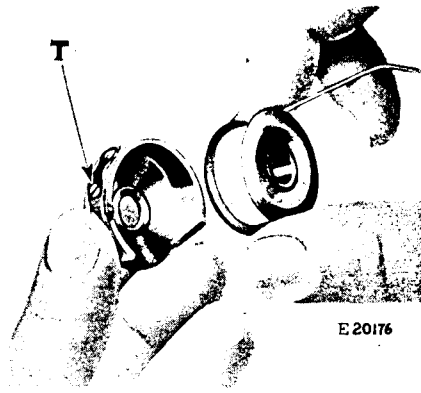

Fig. 5

With the left hand, hold the bobbin case cap as shown in Fig. 5, the tension spring being at the left, and place the bobbin into it.

Then pull the thread into the slot (1, Fig. 6) in the edge of



Fig. 7

Hold the bobbin between the thumb and forefinger of the right hand, as shown in Fig. 5, the thread drawing on the top from the left toward the right.

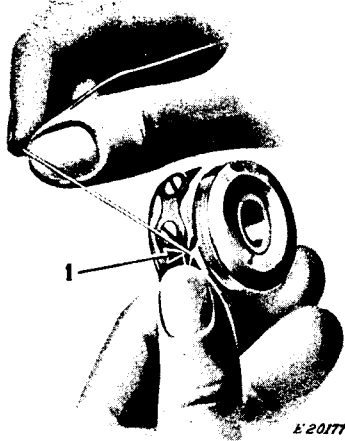

Fig. 6

the bobbin case cap, draw the thread under the tension spring and into the notch in the end of the tension spring, as shown in Fig. 7.

To Replace the Bobbin Case Cap

After threading, take the bobbin case cap in the right hand, holding the bobbin in the cap with the forefinger, and place it on the centre stud of the bobbin case base with the opening in the side of the bobbin case cap opposite the upwardly projecting part of the bobbin case base. Then push down the latch and replace the slide, leaving a loose end of thread about three inches long above the slide. When closing the slide, leave just enough space for the thread to pass through.

To Set the Needle

Turn the balance wheel over toward you by hand until the needle bar moves up to its highest point; loosen the set screw and put the needle up into the needle holder as far as it will go with the long groove toward the left and the eye directly in line with the arm of the machine, then tighten the set screw.

To Adjust the Piercer

The piercer (F, Fig. 9) must be set according to the length of stitch and should be adjusted to enter the puncture made by the needle in the body of the goods. Should it be necessary to move the piercer to the right or left, loosen the screw (D, Fig. 9) and move the piercer holder to the right or left as required. Should it be necessary to move the piercer forward or backward, this can be done after loosening the screw (E, Fig. 9). When the piercer has been correctly adjusted, firmly tighten the screws (D and E).

To Regulate the Length of Stitch

The length of stitch is regulated by moving the end of the connection (K, Fig. 10) which is fastened by the hexagon nut (J, Fig. 10) in the slide on the upright part of the arm. To increase the length of stitch, loosen the hexagon nut (J) and move the connection away from you in the slide. To shorten the stitch, move the connection toward you in the slide. When the desired length of stitch has been obtained, tighten the hexagon nut (J). Care should be taken to see that the length of stitch is adjusted according to the material which is being sewn. A stitch that is too short will not leave a sufficient number of threads between the openings in fine material. If the stitches are made too close together, they may be cut by the piercer.

To Thread the Needle

(See Figs. 8 and 10)

Pass the thread from the unwinder from back to front through the upper hole (1, Fig. 10) in the pin on top of the machine,

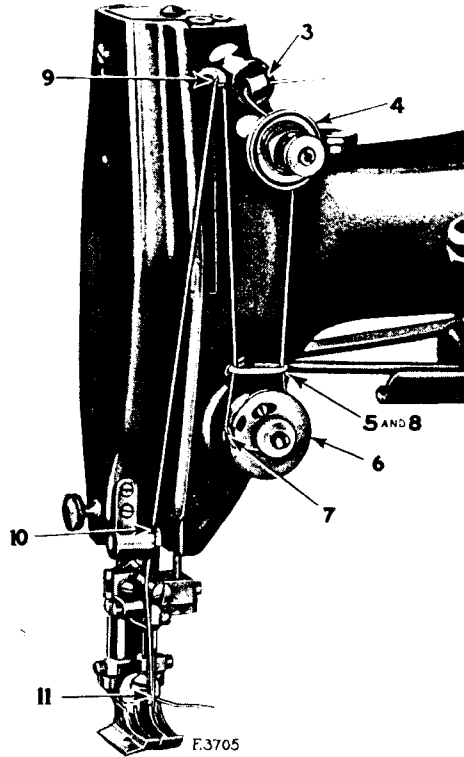

Fig. 8. Threading the Needle

from right to left through the lower hole (2, Fig. 10) in the same pin, into the thread guide (3, Fig. 8), down around the right side between the tension discs (4), down through the thread guide (5), down and from right to left around the thread controller (6) into the thread controller spring (7), up and through the thread guide (8), from right to left through the hole in the end of the take-up lever (9), between the discs of the thread guide (10) from the front, and from left to right through the eye of the needle (11).

Draw about three inches of thread through the eye of the needle with which to commence sewing.

To Prepare for Sewing

With the left hand hold the end of the needle thread, leaving it slack from the hand to the needle, turn the balance wheel over toward you until the needle moves down and up again to its highest point, thus catching the bobbin thread; draw up the needle thread and the bobbin thread will come up with it through the hole in the throat plate. Lay both threads back under the presser foot and close the right hand slide.

To Commence Sewing

Place the material beneath the presser foot so that when the needle has vibrated to the extreme right it will enter the inside edge of the hem, then lower the presser foot and commence to sew, turning the balance wheel over toward you.

To Remove the Work

Let the thread take-up lever rest at its highest point, raise the presser foot and draw the work back and cut the threads close to the material.

To Regulate the Pressure on the Material

The pressure on the material is regulated by the thumb screw (N, Fig. 11) at the back of the machine. To increase the pressure, turn this thumb screw downwardly. To decrease the pressure, turn the thumb screw upwardly. The pressure should be only heavy enough to enable the feed to move the work along evenly.

To Regulate the Tensions

The tension on the needle thread is regulated by the thumb nut (H, Fig. 10) at the front of the tension discs. To increase the tension, turn this thumb nut over toward the right. To decrease the tension, turn the thumb nut over toward the left.

The tension on the bobbin thread is regulated by means of the screw (T, Fig. 5) nearest the centre of the bobbin case cap tension spring. To increase the tension, turn this screw over toward the right. To decrease the tension, turn the screw over toward the left.

To Regulate the Width of Bight

The width of bight of the needle is regulated by moving the end of the needle vibrating lever pitman connection (M, Fig. 10) which is fastened by the screw (L, Fig. 10) on the front of the machine. To increase the width of bight, loosen the screw (L) and move the connection (M) downwardly. To decrease the width of bight, move the connection upwardly. When the desired width of bight has been obtained, tighten the screw (L).

To Adjust the Needle Holder

Should it be necessary to increase the width of bight of the needle on the hem, this can be accomplished by loosening the

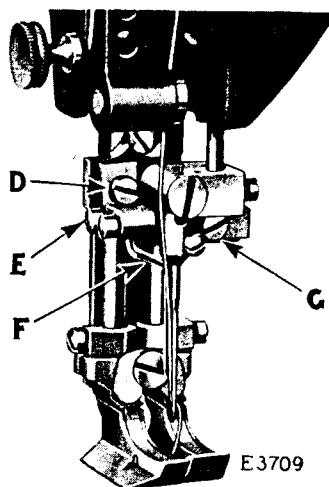

Fig. 9. Adjustment of Needle Holder

screw (G, Fig. 9) and moving the needle holder to the right. To decrease the width of bight on the hem, move the needle holder to the left. When the desired width of bight on the hem is obtained, tighten the screw (G).

To Oil the Machine

To ensure easy running and prevent unnecessary wear of the parts which are in movable contact, the machine requires oiling and when in continuous use, it should be oiled at least twice each day.

Use "TYPE B" or "TYPE D" OIL, sold only by Singer Sewing Machine Company. For description of these oils, see inside front cover.

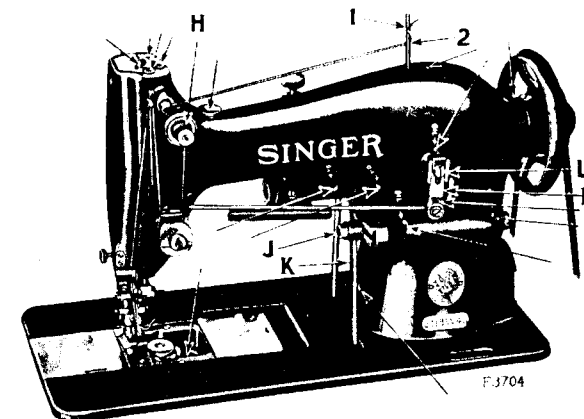

Fig. 10. Oiling Points at the Front of the Machine

The places where the machine should be oiled are indicated in Figs. 10, 11, 12 and 13, by arrows pointing to the oil holes and bearings.

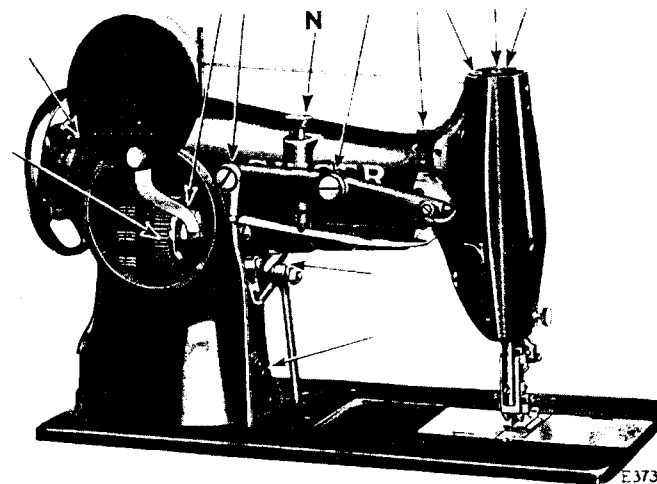

Fig. 11. Oiling Points at the Back of the Machine

INSTRUCTIONS FOR ADJUSTERS AND MACHINISTS

To Time the Cams

To determine whether the feed lifting cam and gear (U, Fig. 14), needle vibrating cam (V, Fig. 14) and feed driving cam

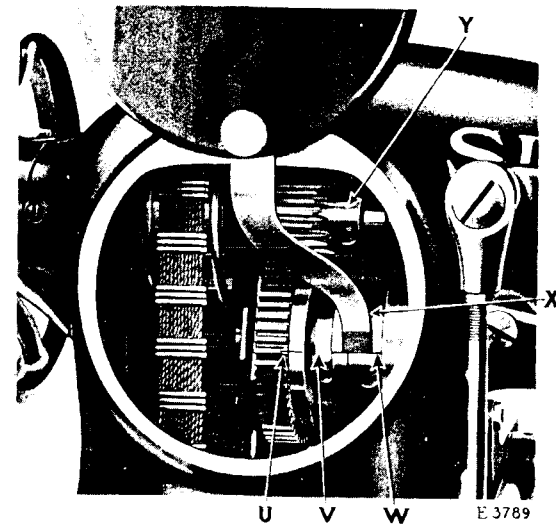

Fig. 14. Showing Timing Finger at Back of Machine for Timing Cams (U, V and W)

(W, Fig. 14) are correctly timed, remove the face plate and raise the round cover plate at the rear of the machine. Turn the balance wheel over toward you until the needle bar is on its upward stroke, after having completed the stitch on the hem (generally known as the first stitch), and the lower timing mark on the needle bar is just visible at the lower end of the upper needle bar bushing, as shown at Z, in Fig. 15. When the needle bar is in this position, the horizontal marks on the needle vibrat-

ing cam (V) and feed driving cam (W) and the line on the side of the ground-off tooth of the feed lifting cam and gear (U) should

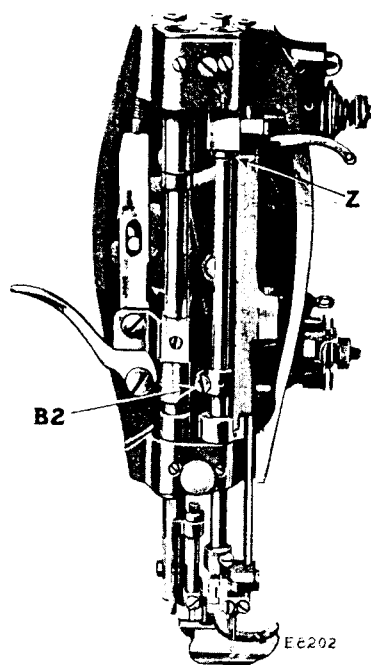

Fig. 15. Showing Lower Timing Mark on Needle Bar Centred with Lower End of Needle Bar Bushing (Z)

be in line with each other and register with the end of the timing finger (X) as shown in Fig. 14, if the cams are correctly timed.

It is necessary that the timing marks on the three cams (U, V and W) should always be in line with each other. If they are not, loosen the two set screws in each of the cams (V and W) and turn the cams until the horizontal lines marked on them register with the line on the side of the ground-off tooth of the feed lifting cam and gear (U); then firmly tighten the set screws.

In case the cams (U, V and W) are in time with each other, but not in time with the needle bar, loosen the two set screws in the small gear (Y, Fig. 14) and turn the feed lifting gear cam (U) until the lines on the cams (U, V and W) register with the

end of the timing finger (X), then tighten the two set screws. When making this adjustment, be sure to have the **lower timing mark** on the needle bar just visible at the lower end of the upper needle bar bushing, as shown at Z, in Fig. 15, when the needle bar is on its upward stroke after having completed the stitch on the hem, generally known as the first stitch.

To Set the Needle Bar at the Correct Height

Turn the balance wheel over toward you until the needle bar moves down to its lowest point. When the needle bar is in this position, the **upper timing mark** on the needle bar should be just visible at the lower end of the upper needle bar bushing (Z, Fig. 15).

In case the needle bar is not set at the correct height, loosen the screw (B2, Fig. 15) in the lower end of the needle bar connecting link and move the needle bar up or down until it is at the correct height, as instructed above, then firmly tighten the screw (B2) in the needle bar connecting link.

To Time the Sewing Hook

To determine whether the hook is correctly timed, turn the balance wheel over toward you until the **lower timing mark** on the needle bar is just visible at the lower end of the upper needle bar bushing, as shown at Z, in Fig. 15, when the needle bar is on its upward stroke. When the needle bar is in this position, the point of the hook should be at the centre of the needle.

In case the hook is not correctly timed, loosen the two set screws in the belt pulley (A2, Fig. 13) on the underside of the machine and turn the hook until it is in the correct position, as instructed above; then firmly tighten the two set screws in the belt pulley.

To Set a Needle Bar which has no Mark

Set the needle bar so that when it rises $\frac{3}{8}$ inch from its lowest position, the point of the hook will be at the centre of the needle blade and about $\frac{1}{8}$ inch above the eye. By looking across the top of the bobbin case, down to the eye, the full length of the eye should be seen below and close up to the point of the hook.

Thread Loop Guard

The thread loop guard (C2, Fig. 16) serves to back up the needle and also to prevent skipping of stitches.

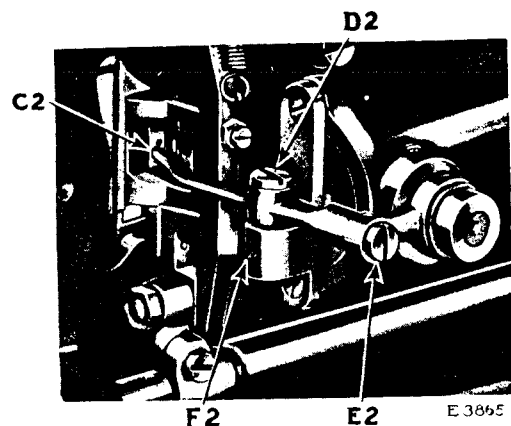

Fig. 16. Adjustment of Thread Loop Guard

The thread loop guard should be set so that it is close to the needle when the hook point is taking the loop from the needle, but at no time should the guard actually touch the needle.

To Adjust the Thread Loop Guard to or From the Needle

Loosen set screw (F2, Fig. 16) and turn eccentric stud (D2, Fig. 16) slightly to the right to move the guard toward the needle, or to the left to move it from the needle; after the proper adjustment has been made, tighten set screw (F2).

If for any reason, such as removing the feed dog, or filling gear case with grease, it is desirable to swing the thread loop guard out of position, and at the same time not to disturb its timing, remove screw (E2, Fig. 16), after which the guard can be moved out of place, and when screw (E2) is replaced, the guard is again in its proper position.

To Remove the Belt from Within the Arm

Slide arm shaft connection belt (A2, Fig. 13) off the hook driving belt pulley and remove the balance wheel; loosen the arm shaft bushing (back) position screw at the back of the arm and remove the bushing; draw the belt through the hole under the round cover plate on back of the machine as far as possible, slip belt off the arm shaft belt pulley and draw it out through the space which was occupied by the bushing.

When replacing the belt, see that the sewing hook and needle bar are in correct time before running the belt on the lower pulley and verify the correctness of the timing before commencing to sew. See page 17.

To facilitate the replacing of the belt on the lower pulley, use belt replacer 235780 (A, Fig. 17). Rest the replacer in the

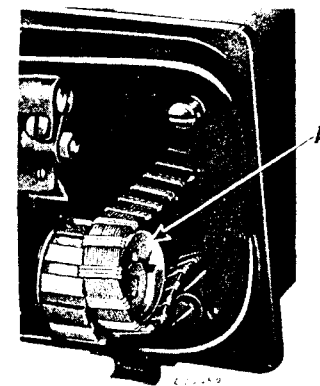

Fig. 17. Putting Belt on Lower Pulley with Belt Replacer 235780

loop of the belt and slide it over the hub of the pulley, as shown in Fig. 17, having the notches in the replacer engage the two set screws in the hub of the pulley. Turn the balance wheel toward you until the belt is fully over the pulley, then remove the replacer.

Note: As belt replacer 235780 will serve for several machines, it is not regularly furnished with the machine, and must be ordered separately.