

SINGER
11W6 & 11W8

USE ONLY **SINGER*** OILS and LUBRICANTS

*They insure freedom from lubricating trouble and
give longer life to sewing equipment*

The following are the correct lubricants for this machine:

TYPE B — MANUFACTURING MACHINE OIL, HEAVY
GRADE

When a stainless oil is desired, use:

TYPE D — MANUFACTURING MACHINE OIL, STAIN-
LESS, HEAVY GRADE

OTHER **SINGER** LUBRICANTS

TYPE E — STAINLESS THREAD LUBRICANT

For lubricating the needle thread of sewing machines for
stitching fabrics or leather where a stainless thread lubri-
cant is required.

TYPE F — MOTOR OIL

For oil lubricated motors and plain bearings in power
tables and transmitters.

NOTE: All of the above oils are available in 1 quart,
1 gallon and 5 gallon cans or in 55 gallon drums.

GEAR LUBRICANT

This specially prepared grease is recommended for gear
lubrication on manufacturing sewing machines.

BALL BEARING LUBRICANT

This pure grease is specially designed for the lubrication
of ball bearings and ball thrust bearings of motors and
electric transmitters, ball bearing hangers of power tables,
etc. **Furnished in 1 lb. and 4 lb. tins.**

Copyright, U. S. A.,
1921, 1926 and 1927,
by The Singer Manufacturing Company
All Rights Reserved for all Countries

2036 w

INSTRUCTIONS FOR USING AND ADJUSTING **SINGER*** SEWING MACHINES

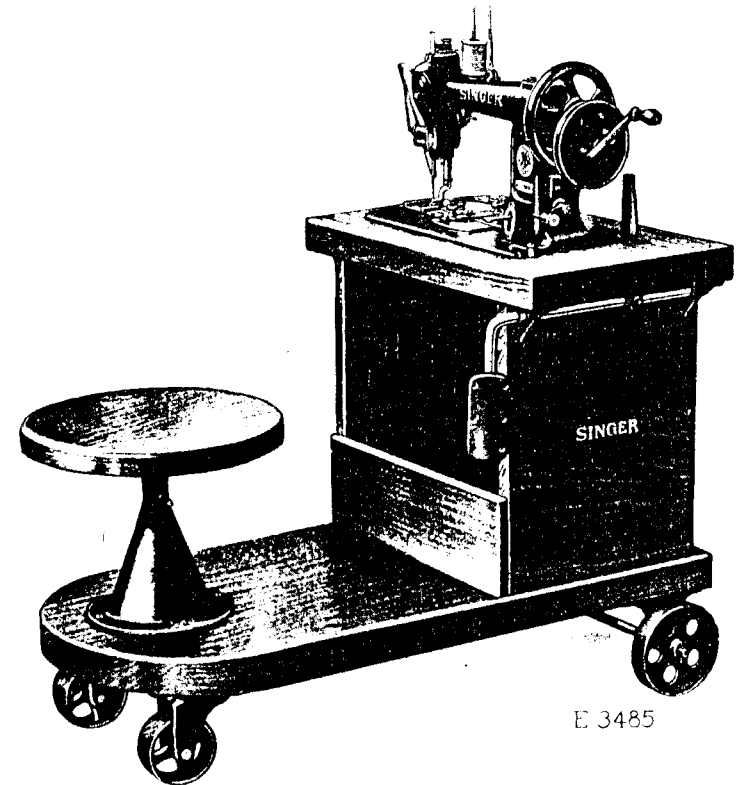

E 3485

Machine No. 11w6 Completely Equipped

11w6 AND 11w8

FOR

JOINING THE ENDS OF TAPE OR CANVAS BELTS

* A TRADE-MARK OF

THE SINGER MANUFACTURING CO.

TO ALL WHOM IT MAY CONCERN:

The improper placing or renewal of the Trade-Mark "SINGER" or any other of the Trade-Marks of The Singer Manufacturing Company (all of which are duly Registered Trade-Marks) on any machine that has been repaired, rebuilt, reconditioned, or altered in any way whatsoever outside a SINGER factory or an authorized SINGER agency is forbidden.

THE IMPORTANCE OF USING **SINGER*** PARTS AND NEEDLES IN **SINGER** MACHINES

The successful operation of SINGER machines can only be assured if SINGER parts and needles are used. Supplies are available at all SINGER Shops for the Manufacturing Trade, and mail orders will receive prompt attention.

SINGER Needles should be used
in SINGER Machines.
These Needles and their Containers
are marked with the
Company's Trade-Mark "SIMANCO.*" 1

Needles in Containers marked
"FOR SINGER MACHINES"
are NOT **SINGER** made needles. 2

DESCRIPTION

Machines 11w6 and 11w8 are fitted with hand driving attachment, have a rotary hook and make the lock stitch and are intended for use in cotton mills for joining the ends of tape or canvas belts which drive the cotton winders and twisters on the spinning frames.

The joining of the ends of the belt is done by lapping one end of the belt over the other and sewing the two ends together with several short parallel lines of stitching which are made lengthwise of the belt and uniformly spaced apart across the width of the belt, as shown in Fig. 11, page 14.

The machines are fitted with a special belt guide attachment which is adjustable to accommodate belts up to 2½" wide. The belt guide is connected with a pivoted lever by which the belt can be moved sideways to make the distance between the lines of stitching either $\frac{3}{8}$ " or $\frac{5}{8}$ " inch, as desired.

In addition, the machines have a reversible drop feed, controlled by a conveniently located hand lever which enables the operator to feed the material backward or forward and thus make the successive parallel rows of stitches without turning the belt being sewn.

Machine 11w6 is mounted on a small portable truck equipped with four wheels, two of which are ball bearing swivel wheels so that the truck can be quickly moved from one place to another. For convenience in operating the machine, a stool, which can be adjusted to any height suitable to the operator, is mounted on the truck. The large compartment below the machine is used to carry a supply of new belts for immediate use. Knee lifter 221826 is provided for raising or lowering the presser foot.

Machine 11w8 is mounted on wood base. Knee lifter 221899 is provided for raising or lowering the presser foot.

NEEDLES

Needles for Machines Nos. 11 w 6 and 11 w 8 are of Class and Variety 128x3 and are made in sizes 9, 10, 11, 12, 13, 14, 16, 18, 20, 22, 23, 24 and 25.

The needle which is best adapted for the work that the machine is fitted to do is set in the machine at the factory.

The size number of the needle is marked upon its shank.

The Sizes. The size to be used should be determined by the size of the thread which must pass freely through the eye. If rough or uneven thread is used or if it passes with difficulty through the eye of the needle, the successful use of the machine will be seriously interfered with.

Orders for needles must specify the **quantity** required, the **size**, also the **class** and **variety** numbers separated by x.

The following are details of an intelligible order:

"100 No. 12—128 x 3 Needles."

RELATIVE SIZES OF NEEDLES AND THREAD

SIZE NUMBERS OF NEEDLES	COTTON THREAD	SILK THREAD
10	100 to 150	000 to 00
11	90 " 100	00
12	80 " 90	O
13	70 " 80	A
14	60 " 70	A
15	50 " 60	B
16	40 " 50	C
18	30 " 40	C
20	24 " 30	D
22	16 " 24	E

TWIST, LINEN AND COTTON THREAD AND NEEDLES

Do not use poor thread or needles. Any good thread will work well, but you must not expect to make a smooth even stitch with poor rough thread, nor can you expect a machine

to work well with a cheap grade of needles made in imitation of ours. It is our interest to maintain the reputation of the machine and therefore we always supply the best. Persons living at a distance from a **SINGER** Shop can send by mail, enclosing the money, and orders will be filled and forwarded promptly.

In using slack twist or uneven silk, should it be frayed or roughened, the needle is too fine or too sharp, or has a hooked point made by striking the throat plate. A hook may be easily honed off the needle.

For ordinary work use the same size of thread on the bobbin as in the needle.

Use the fine throat plate with needles from No. 10 to No. 16; for larger needles the coarse throat plate must be substituted, as the fine one would chafe off the thread.

TO SET THE NEEDLE

Turn the balance wheel from you until the needle bar is at its highest point, loosen the needle set screw, insert the shank of the needle in the needle bar with the long groove toward the upright part of the arm; be sure to push the needle as far up as it will go and secure it firmly by turning the needle set screw with a screw driver.

It may be necessary to turn the needle slightly to the right or left for some threads, if stitches are missed.

SINGER Needles should be used
in SINGER Machines.
These Needles and their Containers
are marked with the
Company's Trade-Mark "SIMANCO.*" 1

Needles in Containers marked
"FOR SINGER MACHINES"
are NOT **SINGER** made needles. 2

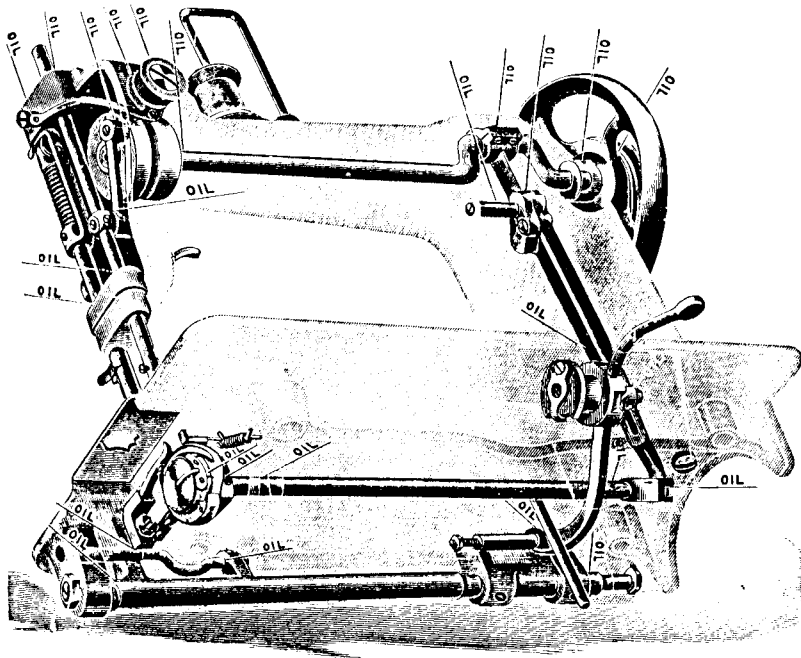

Fig. 2

TO OIL THE MACHINE

Use **"TYPE B"** or **"TYPE D" OIL**, sold only by Singer Sewing Machine Company. For description of these oils, see inside front cover.

Good oil is the life of the machine and should be regularly used on any surface of metal which comes in movable contact with another surface.

The dotted lines (see Fig. 2) indicate the places where oil, in small quantities, should be applied every day when the machine is in constant use.

Loosen the balance wheel nut and oil the loose pulley which permits the belt to wind the bobbin without running the machine (see Fig. 7).

Oil the bobbin winder spindle.

There are four oil holes on top of the arm. Through the large hole near the needle bar, when the needle bar is at its highest position, oil the needle bar connecting link, and when at its lowest position oil the groove in the take-up cam.

Oil the take-up lever bearing through the hole over the take-up lever. Oil the arm shaft bearing (front) through the next hole toward the right and oil the arm shaft bushing (back) through the hole near the balance wheel. Move the arm cap aside and oil the arm shaft connection and feed driving crank. Remove the arm side plate and oil the arm shaft connection slide block, the feed driving slide block and both ends of the feed driving crank link.

Oil the hook shaft bearing (back) through the hole near the base of the arm fronting toward the needle and oil the hook shaft bearing (front) through the hole in the bed slide (back).

Remove the face plate by loosening the large screw near the tension discs and pushing the face plate up over the head of the screw, then oil the needle bar connecting stud, the needle and presser bars and wherever there is friction.

The parts on the underside of the machine may be cleaned and oiled best by removing the belt and tipping the machine back as shown (see Fig. 2).

A very little oil must be occasionally put upon the edge of the bobbin case, with an oiled rag to prevent a clicking sound (see Fig. 2).

Oil the feed lifting cam under the feed bar, the hook shaft crank, and the screw centers at both ends of the feed bar, feed driving rock shaft and crank.

After oiling, raise the presser foot and run the machine rapidly a minute; then wipe off all superfluous oil, to prevent soiling the goods. If the machine runs hard at any time, it is certain that some part needs oiling.

Never run the machine with the presser foot down except when sewing, as it will scratch the presser foot and dull the feed dog.

When the machine has been neglected or becomes gummed it should be soaked well with kerosene or benzine and run for a short time, keeping all parts flooded with oil until it runs freely, then wipe thoroughly to remove all old oil and dirt and oil as before directed.

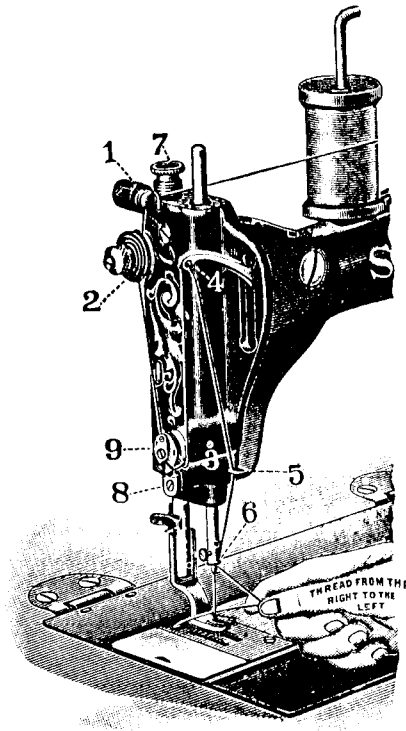

Fig. 3

TO THREAD THE NEEDLE

Place the spool on the spool holder, pass the thread under the thread retainer guide wire, through thread retainer (1), down (back) between tension discs (2), thence under thread controller spring (3), up into take-up lever (4), down to thread leader (5) and needle bar thread guide (6), then thread the needle from right to left as shown in Fig. 3 and draw two or three inches of thread through the eye of the needle when the take-up lever is at its highest point.

Do not let thread retainer (1) or tension discs (2) become clogged with lint, dirt or knots of thread.

TO TAKE OUT THE BOBBIN

Remove the bed slide (front); to open the latch easily with the left thumb, have the point of the hook toward you, as shown in Fig. 4.

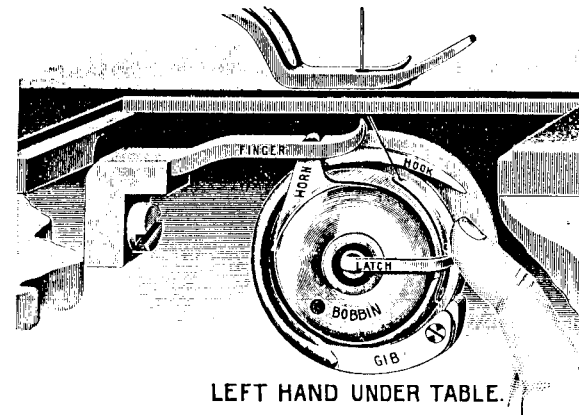

Fig. 4

With the ball of the thumb (not necessary to use the finger or the thumb nail), open the latch until it stands out straight, then brush the bobbin outward, until it hangs on the latch, for removal (see Fig. 5).

The inside of the bobbin case should be wiped out occasionally with an oiled rag to remove lint or dirt.

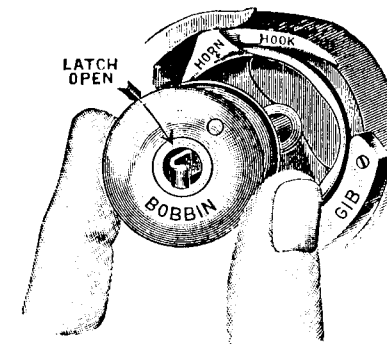

Fig. 5

TO WIND THE BOBBIN

To wind the bobbin without running the machine, push back the pin (A, Fig. 6) and pull the hand wheel (B, Fig. 6) away

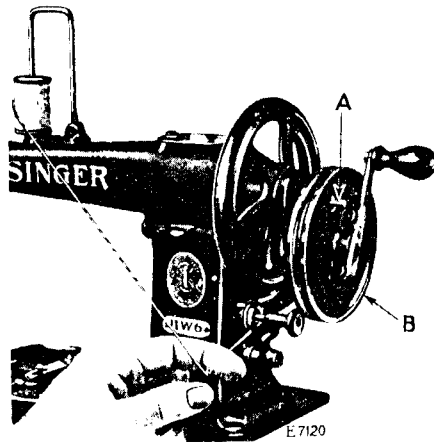

Fig. 6. Winding the Bobbin

from the balance wheel until the internal gear is free from the gear on the balance wheel, then release the pin (A) and it will enter a second groove on the shaft, locking the hand wheel in this position.

Swing the bobbin winder until its pulley comes in contact with the hand wheel (B) and place the bobbin on the bobbin winder spindle.

Place the spool of thread on the spool pin on top of the machine and pass the end of the thread from the inside through the hole in the side of the bobbin. Then turn the hand wheel by means of the handle of the driving attachment. The end of the thread must be held by the hand until a few coils are wound and should then be broken off.

If the bobbin does not revolve with the spindle, spread the slot in the spindle with a screwdriver.

When the bobbin is nearly full, within three layers of thread from the top edge of the bobbin, stop winding and push down the bobbin winder. Then replace the hand wheel to operative position.

TO REMOVE THE BOBBIN CASE

To remove the bobbin case from the hook, to thoroughly clean the bobbin case and hook, turn the balance wheel until

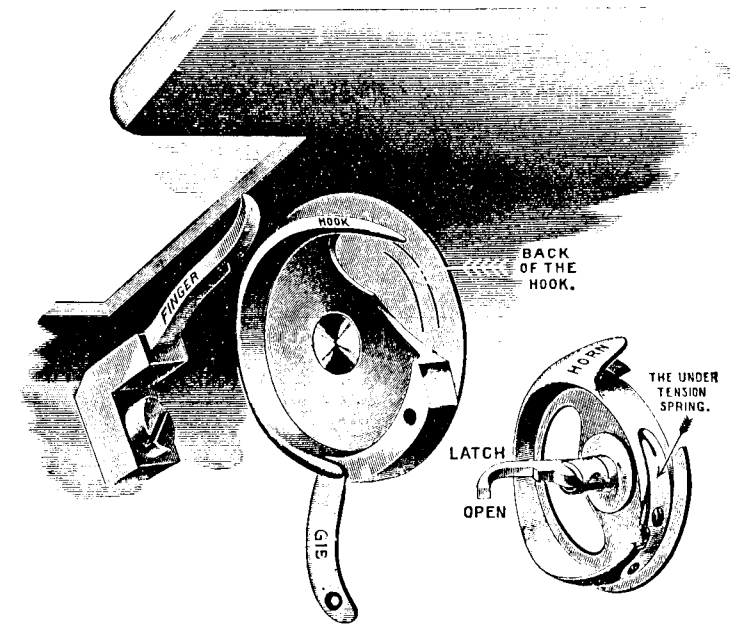

Fig. 7 shows the Hook Gib open and the Bobbin Case removed

the heel of the hook is on a line with the second notch in the bobbin case, remove the screw at the end of the hook gib, and open the hook gib, as shown above, then lift out the bobbin case.

Back of the bobbin case should be kept clean to prevent soiling the thread or obstructing the loop. See that there is no lint or dirt under the tension spring.

When returning the bobbin case to the hook, be sure to have the bobbin case horn in the notch of the bobbin case stop, and the second notch of the bobbin case at the heel of the hook.

Close the hook gib and turn the screw in firmly, being careful not to damage the head of the screw.

TO REPLACE THE BOBBIN AND THREAD THE BOBBIN CASE

With the left hand place the bobbin in the bobbin case with the thread leading from the top toward you; hold the end with

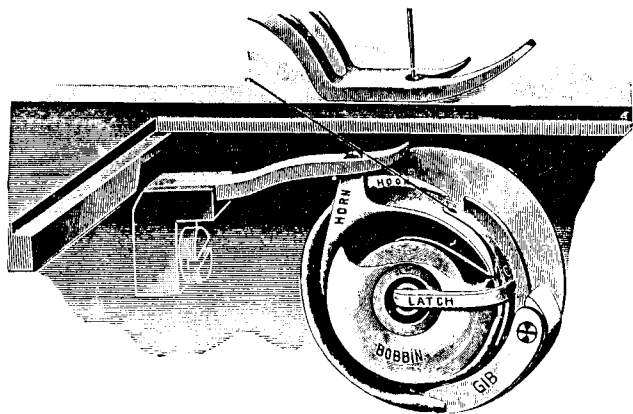

Fig. 8

the left hand (see Fig. 8); guide the thread into the notch and close the latch, then pull the thread from you until it is drawn up under the notch at the end of the tension spring.

The bobbin in Fig. 8 is shown partly cut away, giving a view of the direction in which the thread should unwind.

TO DRAW UP THE UNDER THREAD

Let the thread extend through the needle two or three inches when the take-up lever is at its highest position. Hold

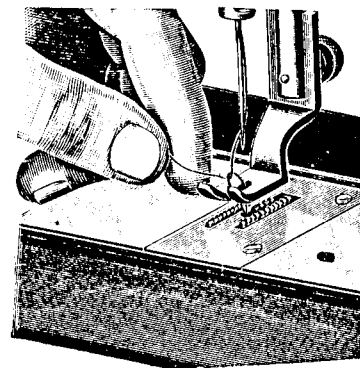

Fig. 9

the end of the upper thread slack between the hand and needle and turn the balance wheel carefully from you while the needle goes down and up, and the point down to the presser foot (see Fig. 3), bringing the take-up lever to its highest position. Then draw up the upper thread and the under thread will come up with it (see Fig. 9). Pass both threads back under the presser foot.

TO ADJUST THE MACHINE FOR JOINING THE ENDS OF BELTS

(See Fig. 10)

Adjust the guide (D) according to the width of belt to be sewn, by loosening the thumb nut (F, Fig. 10) and moving the guide (D) the desired distance from the fixed side of the guide (E), after which securely tighten the thumb nut (F).

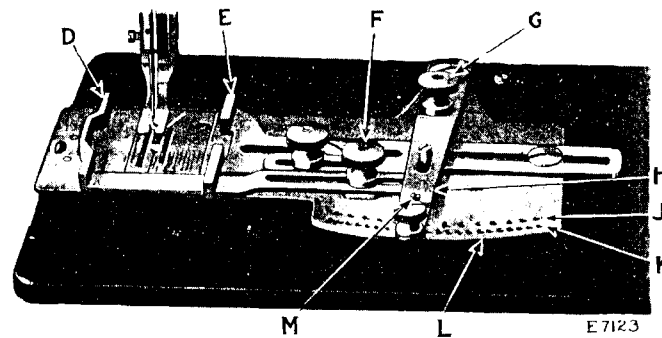

Fig. 10. Adjustments on the Machine

E7123

(See Fig. 10)

The distance between the parallel lines of stitching is controlled by the lever (H) by means of which the belt is moved sideways. The spacing between the lines of stitching is made uniform by inserting the stud (M) on the underside of the lever (H) into holes placed an equal distance apart in the plate (L). There are two rows of holes in the plate (L), the outer row (K) having the holes spaced $\frac{3}{32}$ inch apart and the inner row (J) having the holes spaced $\frac{5}{32}$ inch apart. After loosening the thumb nut (G), the lever (H) can be adjusted to permit the stud (M) to enter either row of holes as desired, then tighten the thumb nut (G).

To join the ends of the belt, lap one end of the belt over the other end and place the ends in this position in the guide, which

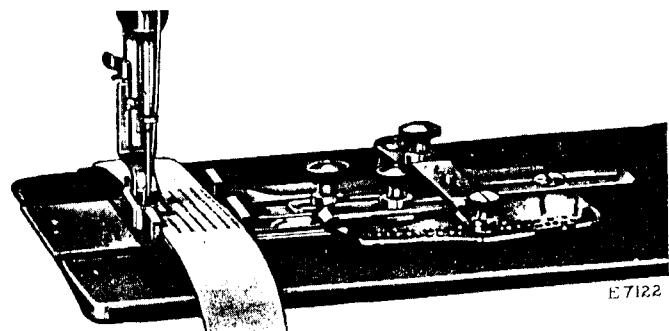

Fig. 11. Joining Ends of Belt

should be set so that the needle will enter the belt the proper distance from the edge for the first line of stitching. Lower the presser foot and sew the first seam nearly to end of lap, then raise the presser foot, move the lever (H) one hole, thus moving the belt, lower the presser foot, reverse the feed by means of the handle (I, Fig. 16) and sew the second seam parallel to the first. Repeat this operation until the full width of the belt is covered by several parallel lines of stitching running lengthwise of the belt, as shown in Fig. 11.

Note: The first line of stitching may be started on either the right or left side of the belt, as desired.

TENSIONS

The needle and bobbin threads should be locked in the centre of the thickness of the material, thus:



Fig. 12. Perfect Stitch

If the tension on the needle thread is too tight, or if that on the bobbin thread is too loose, the needle thread will lie straight along the upper surface of the material, thus:



Fig. 13. Tight Needle Thread Tension

If the tension on the bobbin thread is too tight, or if that on the needle thread is too loose, the bobbin thread will lie straight along the under side of the material, thus:



Fig. 14. Loose Needle Thread Tension

TENSION ON UPPER THREAD

Regulate the tension on the upper thread by turning the nut on top of tension (see 2, Fig. 3) toward you to tighten and from you to loosen the tension. When the presser lifter is down the upper tension may be tested by hand.

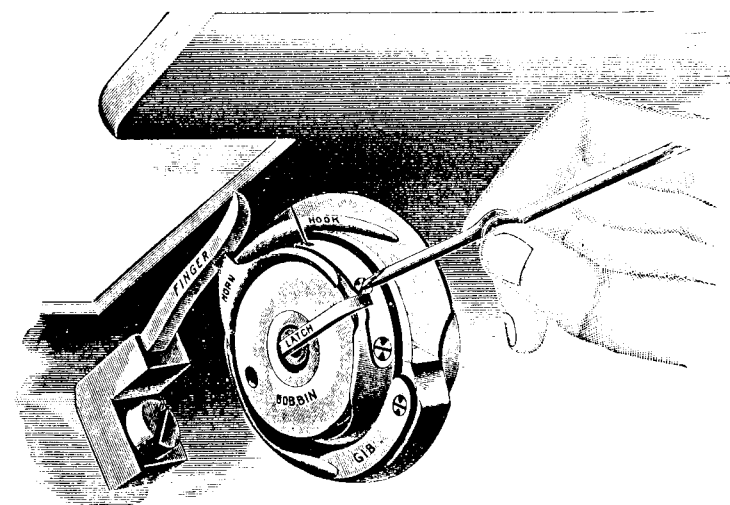

Fig. 15

TENSION ON UNDER THREAD

To regulate the under tension, remove the bed slide (front), tip the machine back and turn the balance wheel from you until the hook points toward you and the hook gib is below the latch as shown in Fig. 15.

The tension is regulated by the screw in the center of the spring above the latch. With the small screw driver turn this screw one-quarter or one-half around to the right to tighten, or to the left to loosen the tension.

The under tension, when once regulated, will rarely require any change, therefore, the proper relation of upper and under tensions should be produced by changes of the upper tension only.

For general work the tension on the under thread should be medium.

TO CHANGE THE LENGTH OF STITCH

Raise feed regulating handle (1, see Fig. 16) as high as it will go and the machine will feed from you with the longest

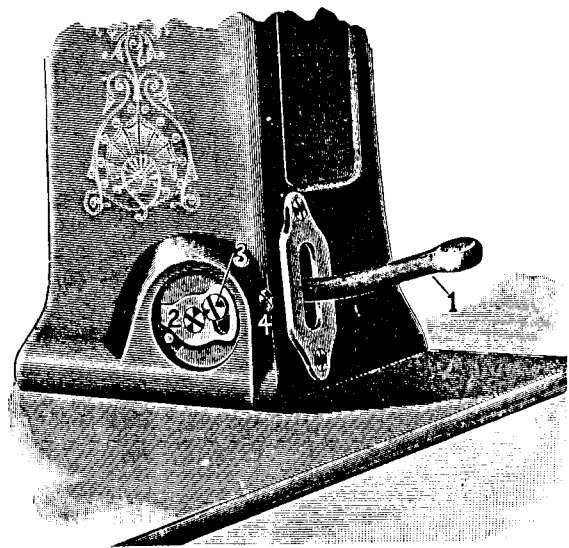

Fig. 16

stitch. As the handle is pushed downward the stitch shortens until the goods will not move; continuing the downward movement of the handle reverses the feed and moves the goods toward you. If the stitch changes length while the machine is running, tighten screw (4). If the handle moves too hard, loosen screw (4) until it moves as easily as desired.

FEED REGULATOR AND REVERSER STOP

The upward movement of the feed regulating handle (see Fig. 16) may be stopped at any position desired by setting stop (2) for the purpose. Should the stitch be shortened or reversed, this adjustment assures the return of the feed to the same length of stitch used before making the change.

Loosen screw (3) and set stop (2) lower for a shorter stitch limit or higher for a longer stitch limit, and retighten the screw.

TO CHANGE THE PRESSURE OF THE PRESSER FOOT ON THE MATERIAL

Turn presser bar thumb screw (7, see Fig. 3) over to the right to make the pressure heavier or over to the left to make it lighter; the pressure should be only heavy enough to prevent the material from rising with the needle and to insure the feed moving the work along evenly; a heavier pressure would make the machine run harder and be of no benefit.

TO REMOVE THE WORK

To remove the work, raise the presser lifter; turn the balance wheel from you until the point of the needle going down reaches the presser foot, bringing the take-up lever to its highest position. Draw the work from you until you can draw the threads into the thread cutter. If the threads do not draw out easily, the needle is not in position, as directed. If the machine is stopped and held as directed, the needle will not unthread when you start to sew if only a short end is left through the needle.

For convenience in taking out the work, the tension of the upper thread is released whenever the presser lifter is raised; but it is not released by the rising of the presser foot as thick goods or seams pass under it.

Causes of the machine not working properly will usually be found in the tension not being correctly adjusted, or its discs may be clogged with lint or knots of thread, or the thread may be too coarse or too fine for the needle, or the needle and thread too coarse or too fine for the throat plate, or the needle bent or blunt. See that a straight needle is pushed up in the needle bar as far as it will go; any particle of lint or dirt which prevents it from going up can be removed through the cross hole in the needle bar.

TO REMOVE THE PRESSER FOOT

Raise the presser lifter and remove the presser foot screw, then draw the presser foot down and out.

THREAD CONTROLLER

The function of the thread controller spring is to hold back the slack of the upper thread until the eye of the needle reaches the goods in its descent.

It may be found advantageous to vary the position of the thread controller spring stop.

The thread controller stop is in the form of a crescent; push on the upper end of the stop to move it for less, and on the lower end for more controller action on the thread.

It may be found necessary to vary the tension of the spring for special requirements.

To vary the tension of the controller spring, loosen the set screw near (3, see Fig. 3) at the right of the spring, remove the face plate, then from the inside turn the stud forward or backward as required and tighten the set screw. In any case where an unusually light tension is used, the tension on the controller spring should be correspondingly light. The coils of the controller spring should be oiled occasionally.

To Place a New Thread Controller in Position. Remove the entire thread controller by taking out screw (8, see Fig. 3) and release the spring by removing screw (9). (Be careful not to lose the small roller.) Place the new spring, roller and screw in their positions. Next put the entire thread controller on the face plate, taking care to slide the little tail, on the coil of the spring, into the notch in the stud over which the coil slides.

Oil the small roller occasionally.

TO CLEAN THE FEED

Remove the needle, presser foot and throat plate. Clean all of the parts about the feed bar, hook and bobbin case, and oil all of the parts where there is friction.

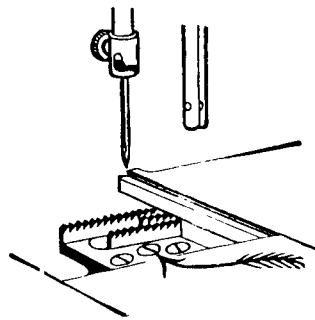

Fig. 17

TO RAISE OR LOWER THE FEED DOG

Should the feed dog or feed bar become worn by long use, leaving the points too low, they may be raised by turning the middle screw to the right. (See arrow point in Fig. 17.) Turning the screw to the left will lower them. The points should rise about $\frac{1}{4}$ of an inch above the throat plate.

KNEE LIFTER

The knee lifter is used for raising the presser foot by knee pressure against the knee plate, leaving both hands free to manipulate the work. If the knee lifter does not raise the presser foot satisfactorily, adjust the rod in the rock lever which connects with the rod in the arm of the machine to lift the presser foot.