

USE **SINGER*** OILS and LUBRICANTS

*They insure freedom from lubricating trouble and give
longer life to sewing equipment*

The following are the correct lubricants for this machine:

TYPE A — MANUFACTURING MACHINE OIL, LIGHT GRADE

*When an oil is desired which will produce a minimum of
stain on fabrics, even after a long period of storage, use:*

TYPE C — MANUFACTURING MACHINE OIL, LIGHT GRADE

OTHER **SINGER*** LUBRICANTS

TYPE E — THREAD LUBRICANT

For lubricating the needle thread of sewing machines for stitching fabrics or leather where a thread lubricant is required.

TYPE F — MOTOR OIL

For oil lubricated motors and plain bearings in power tables and transmitters.

NOTE: All of the above oils are available in 1 quart, 1 gallon and 5 gallon cans.

BALL BEARING LUBRICANT

This pure grease is specially designed for the lubrication of ball bearings and ball thrust bearings of motors and electric transmitters, ball bearing hangers of power tables, etc. Furnished in 1 lb. and 4 lb. tins.

INSTRUCTIONS FOR USING **SINGER*** SEWING MACHINE **212 G 140 212 G 141**

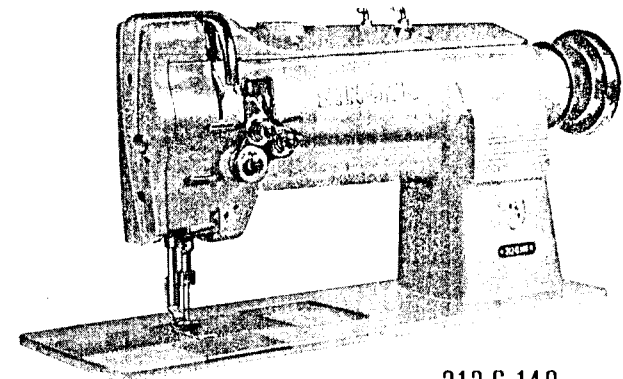

212 G 140

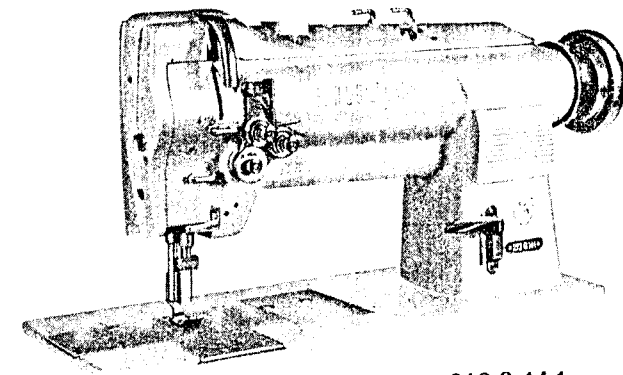

212 G 141

DESCRIPTION

Machine 212G140 has two needles and two belt-driven rotary sewing hooks on a vertical axis. It has a compound feeding mechanism consisting of a needle feed and a drop feed which are simultaneously adjustable for stitches up to six to the inch, and is designed for lock stitching overalls, coats, corsets, brassieres and other work requiring a compound feed. The machine is furnished in gauges from 1/32 to 1-1/2 inches as ordered.

Machine 212 G 141 is the same as the 212 G 140, except for the feed reversing mechanism which can be either hand or foot operated at the will of the operator.

SETTING UP

Fasten the drip pan to the table with its left end even with the left end of the cut-out. Fasten the knee lifter bracket in the location shown in Fig. 2, assembling it so that the lifter rod A does not strike the drip pan. The screw slots in the bracket provide the necessary adjustment. The stop stud B, Fig. 2 should be set to stop the action of the knee lifter as soon as the presser foot is raised enough to trip the hand lever. Then attach the oil jar D, as shown in Fig. 2.

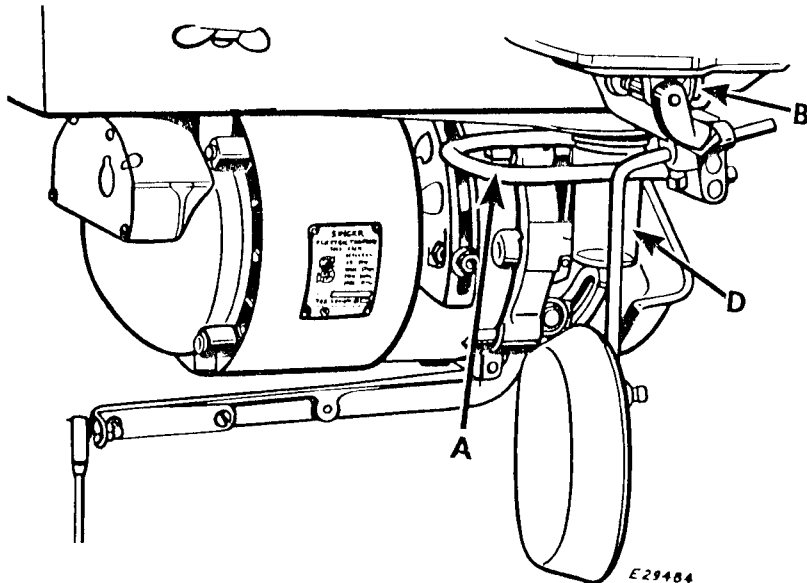

Fig. 2. Knee Lifter, Drip Pan and Oil Jar in Position

The speed recommended for these machines is 4000 R.P.M., depending on the material being stitched. It is advisable to run the machine 500 RPM slower than maximum speed for the first 100 hours.

TO OIL THE MACHINE

When the machine is received from the factory, it should be thoroughly cleaned and oiled.

Use "TYPE A" or "TYPE C" OIL, sold by Singer Sewing Machine Company. See inside front cover of this book for description of these oils.

Before starting the machine, remove the two oil gauges E, Fig. 3, and fill the oil reservoirs in the sewing hook saddles to the full mark on the gauges. It may not be necessary to add oil to these reservoirs every day. However, the oil level must be checked DAILY and kept to the full mark on the gauges.

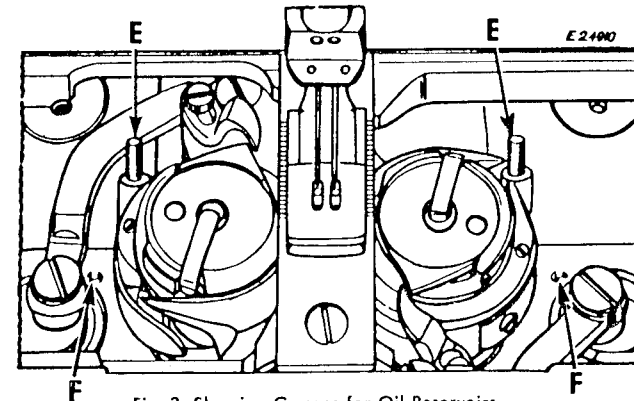

Fig. 3. Showing Gauges for Oil Reservoirs

Oil should be applied at points E and F, Fig. 3 and G, Fig. 4 and as indicated by "OIL" Fig. 24. When machine is in continuous use, the oil level should be checked twice a day.

Fill oil reservoir located on top of arm through oil filler hole G, Fig. 4, to high mark on oil sight F, Fig. 4.

The 212 G 140 and 212 G 141 machines are fitted with the dynamic head-end lubrication device which makes it unnecessary to manually control the flow of oil.

CAUTION: The pump action must be absolutely free of rubbing and has been set for .006 inch between the housing and pump weight at the factory.

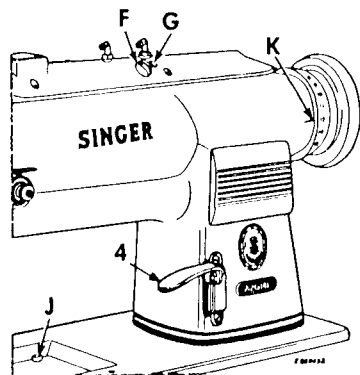

Fig. 4. Oiling Points on the Machine

TO REGULATE OIL FLOW TO HOOK RACEWAY

It is very important to always check the amount of oil received by the hook raceway. To do this, first remove the bobbin case. Now, start the machine and hold a small piece of white paper near the hook for 15 seconds. Remove the paper and a small spray of oil should be visible. If no oil spray shows, check the oil level in the hook saddle reservoirs. Tip the machine back, away from the operator, and loosen the oil control valve set screw **G3, Fig. 19**. Return the machine to its upright position. Turn the oil control valve screw **M, Fig. 5** to the right for more oil or to the left for less oil.

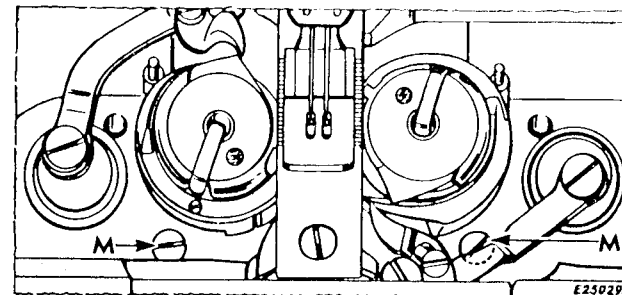

Fig. 5. Sewing Hook Oil Control Valve Screws

After each adjustment, a short test run should be made. This short run is advisable to allow the additional increase of oil to flow through to the oil wick. For decreasing the flow of oil, the short run will allow the excess oil to disperse. After each adjustment, the oil control valve set screw **G3, Fig. 19** must be securely tightened.

NEEDLES . . .

The correct type—

As you know, the needles you use have a very direct effect on the quality, strength and appearance of the stitching produced by your machine. From the standpoint of efficient machine performance, the proper needle is just as necessary as many of the parts inside your machine.

That's why it's so important—for best sewing results and for trouble free operation—to use only the Singer needles recommended here:

Catalogue 1901 (135 x 7) in Sizes 12, 14, 16, 18, 20, 22 and 24

For corset work—

Catalogue 1903 (135 x 11) in Sizes 12, 14, 16, 18 and 20

In selecting a needle of the right size among sizes shown—whether in standard or chromium finish—the eye must be large enough to allow the thread you are using to pass through freely without binding or chafing. A simple test is to thread a short length of sewing thread through the needle eye, hold the thread taut in a vertical position and twirl the needle about the thread. If the size is correct, the needle should slip down the thread easily.

Check for damaged needle—

To avoid poor stitching and possible damage to your machine, check your needles frequently.

THREAD . . .

Use left twist thread for both needles. Either left or right twist thread may be used for the bobbins.

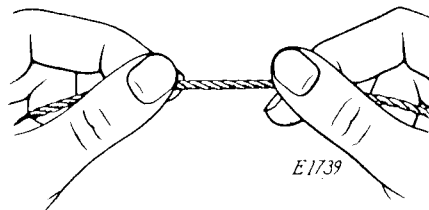

Fig. 6. How to Determine the Twist

Hold the thread as shown above. Twirl the thread over toward you between the thumb and forefinger of the right hand; if left twist, the strands will wind tighter; if right twist, the strands will unwind.

TO SET THE NEEDLES

Turn machine pulley over toward you until needle bar moves up to highest point. Loosen the set screws in the needle holder and put the needles up into the holder as far as they will go. Be certain the inside needle, or the one nearest the upright part of the arm, has its long groove toward the left, and the outside needle, or the one farthest from the upright part of the arm, has its long groove toward the right, the eyes of both needles being directly in line with the machine bed. Now, tighten the set screws.

UPPER THREADING**Outside Needle:**

Pass thread from left spool through threading points on unwinder to machine. Continue threading through threading points 1 through 13. Pass thread from right to left through eye (14) of outside needle.

Inside Needle:

Pass thread from right spool through threading points on unwinder to machine. Continue threading through threading points A through N. Pass thread from left to right through eye (0) of inside needle.

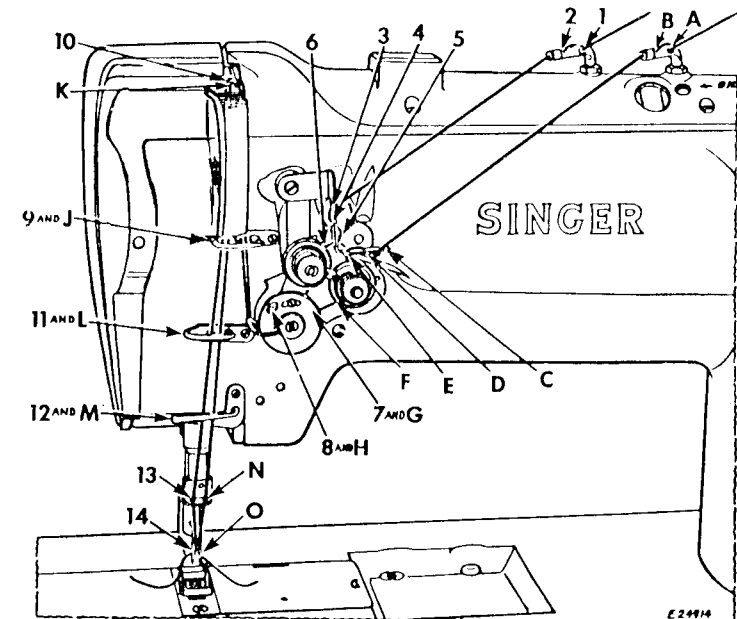

Fig. 6A. Upper Threading

Draw about three inches of thread through the eye of each needle with which to begin sewing.

TO REMOVE THE BOBBINS

Draw out the slide plates in the bed of the machine. Turn the machine pulley over toward you until the needle bar moves up to its highest point. Place the thumb or finger under the bobbin case latches, raise the latches and lift out the bobbins, as shown at N, Fig. 8.

TO WIND THE BOBBIN

(See Fig. 7)

Fasten bobbin winder to table with its driving pulley in front of machine belt, so that the pulley will drop away from the belt when sufficient thread has been wound upon the bobbin.

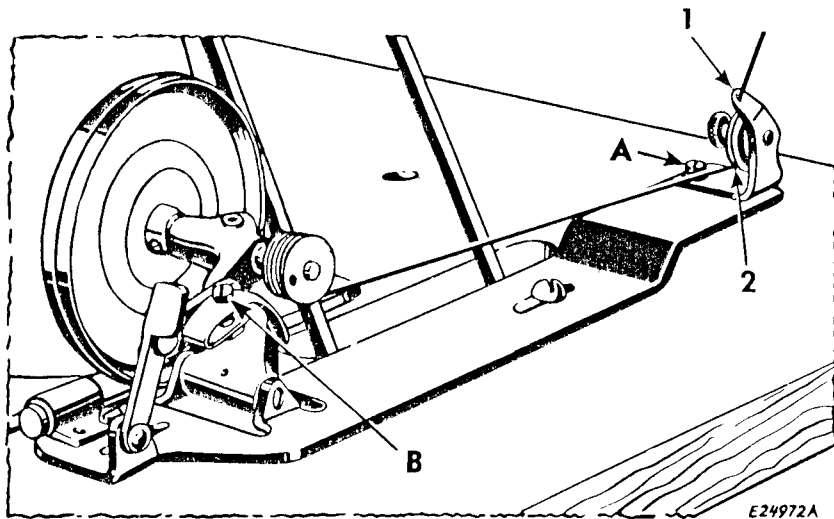

Fig. 7. Winding the Bobbin

Place bobbin on bobbin winder spindle and push it on as far as it will go.

Pass thread down through thread guide 1 in tension bracket, around back and between tension discs 2. Wind the end of thread around bobbin a few times, push bobbin winder pulley over against machine belt and start machine.

When sufficient thread has been wound upon the bobbin, bobbin winder will stop automatically.

If thread does not wind evenly on the bobbin, loosen screw A in tension bracket and move bracket to the right or left as required, then tighten the screw.

The amount of thread wound on the bobbin is regulated by the screw B. To wind more thread on the bobbin, turn the screw B inwardly. To wind less thread, turn the screw outwardly.

Bobbins can be wound while the machine is stitching.

TO REPLACE THE BOBBINS AND THREAD THE BOBBIN CASES

The following instructions apply to both bobbin cases.

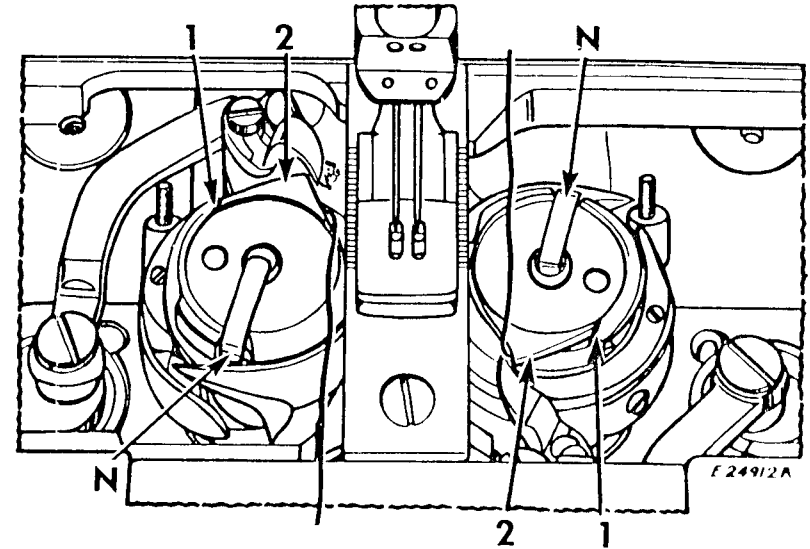

Fig. 8. Threading Bobbin Cases

Hold bobbin between thumb and forefinger of right hand, the thread drawing on the bottom from left to right, and place it on centre stud of bobbin case. Push down latch N, as shown in Fig. 8. Draw the thread into slot 1 in edge of bobbin case and back of projection 2, leaving a loose end of thread about two inches long above the slide. When closing slides, leave just enough space for threads to pass through.

TO PREPARE FOR SEWING

Hold the ends of the needle threads with the left hand, leaving them slack from hand to needles. Turn machine pulley over toward you until needles move down and up again to their highest point, thus catching the bobbin threads. Draw up the needle threads and the bobbin threads will come up with them through holes in the feed dog (see Fig. 9). Lay threads back under presser foot and close the slides.

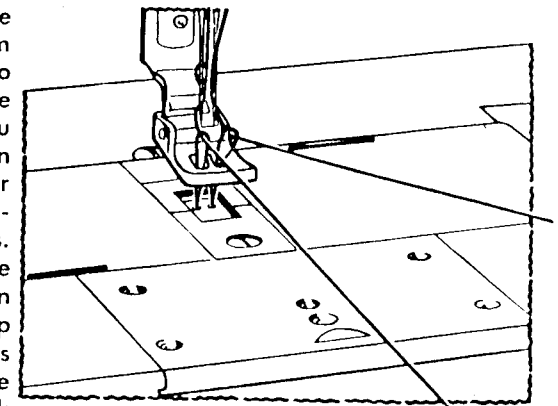

Fig. 9. Drawing Up the Bobbin Threads

TO COMMENCE SEWING

Place material beneath presser foot, lower presser foot and commence to sew.

TO REMOVE THE WORK

Have the thread take-up lever at the highest point, raise the presser foot, draw the work back and cut the threads close to the material. Lay ends of threads back under the presser foot.

TENSIONS

The needles and bobbin threads should be locked in the centre of the thickness of the material, thus:



Fig. 10. Perfect Stitch

If tension on the needle thread is too tight, or if that on the bobbin thread is too loose, the needle thread will lie straight along the upper surface of the material, thus:

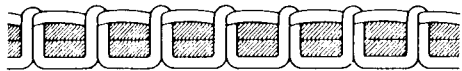

Fig. 11. Tight Needle Thread Tension

If tension on the bobbin thread is too tight, or if that on the needle thread is too loose, the bobbin thread will lie straight along the under side of the material, thus:



Fig. 12. Loose Needle Thread Tension

TO REGULATE THE TENSION

The tensions on the needle threads are regulated by the two thumb nuts **Q**, **Fig. 14** at the front of the tension discs on the front of the machine. To increase the tension, turn these thumb nuts over to the right. To decrease the tension, turn the thumb nuts over to the left.

Tensions on the bobbin threads are regulated by means of the screw nearest the centre of the tension spring, on the outside of each bobbin case. To increase the tension, turn this screw over to the right. To decrease tension, turn the screw over to the left.

TO REGULATE THE LENGTH OF STITCH

The number of stitches per inch is stamped on the machine pulley **Fig. 4** located on the armshaft.

To change the length of stitch, press down the plunger **J**, **Fig. 4** in the bed of the machine, at the same time slowly turning the machine pulley until the plunger enters a notch in the adjustable feed eccentric cam. Still holding the plunger, turn the machine pulley over a part of a revolution until the desired number of stitches per inch on the machine pulley is opposite the reference mark **K**, **Fig. 4** on arm, then release the plunger.

THE FEED REVERSING MECHANISM

To reverse the direction of feed, press down the feed reversing handle **4**, **Fig. 4** and the work will feed toward you. Release the handle and the work will feed away from you.

For foot operation of reverse feed mechanism, connect the feed reversing treadle chain to the feed reversing lever. **F3**, **Fig. 24** underneath the bed of the machine.

TO REGULATE THE PRESSURE ON MATERIAL

The pressure on the material is regulated by the screw **P**, Fig. 13 acting on a flat spring, at the back of the machine. To increase the pressure, turn this screw downward. To decrease the pressure, turn this screw upward. The pressure should be only heavy enough to enable the feed to move the work along evenly.

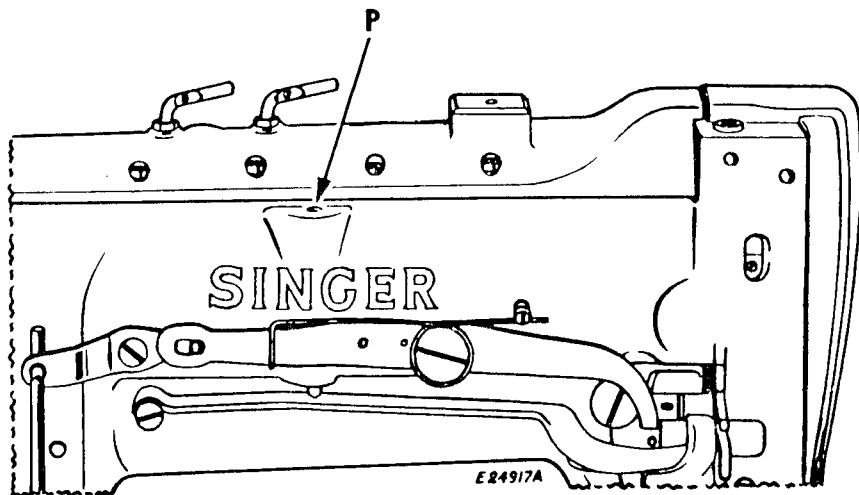

Fig. 13.

NOTE: The instructions on following pages are for Service Representatives only.

THREAD CONTROLLER

The function of the thread controller spring is to hold back the slack of the needle threads until the point of each needle reaches the goods in its descent. Without the controlling action of this spring, the slack thread (especially silk) will sometimes be penetrated by the point of the needle as the needle is descending.

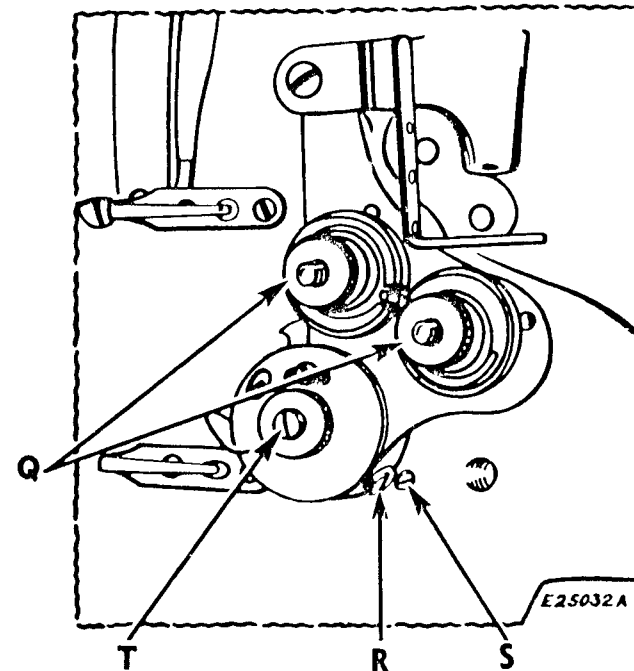

Fig. 14. Adjustment of Thread Controller

To change the thread controller stop for more controller action on the threads, loosen the set screw **R**, Fig. 14 and turn the thread controller spring stop to the right. For less action, turn the thread controller spring stop to the left. Securely tighten the set screw **R** after making adjustments.

It may be found advisable to increase the tension of the spring for coarse thread, or to lessen it for fine thread.

To increase the tension of the thread controller on the threads, loosen the tension stud set screw **S**, Fig. 14, located nearly under the tension stud and, with a screw driver, turn the tension stud **T** slightly to the left. To decrease the tension, turn it to the right. Retighten the stud set screw **S**.

TO SET THE NEEDLE BAR

There are two lines across the needle bar about two inches above the lower end. When the needle bar is at its lowest position, the upper mark should be just visible at the end of the needle bar frame. Be certain the needles are up in the holder as far as they will go.

In case the needle bar is not correctly set, loosen the needle bar connecting stud pinch screw **U**, Fig. 15 and place the needle bar in the correct position as directed above. Retighten the screw **U**.

TO SET A NEEDLE BAR WHICH HAS NO MARK. Set the feed eccentric so there is no feeding motion. Now, set the needle bar so that when it rises .080 inch from its lowest position, and the points of the sewing hooks are at the centres of the needles, the eyes of the needles will be about 1/16 inch below the points of the hooks.

RELATIVE POSITIONS OF NEEDLE BAR AND PRESSER BAR

The distance between the needle bar and presser bar, after adjusting the feed eccentric so there is no feed movement, should be 17/32 inch as shown in Fig. 15.

If the distance between the needle and presser bars is more or less than 17/32 inch, loosen the needle bar frame shaft clamp screw N2, Fig. 20. While the screw is loose, the needle bar frame can be moved forward or backward, as required, until the distance between the needle and presser bars is 17/32 inch. A piece of sheet metal 17/32 inch wide may be used to determine the correct distance. When making the adjustment, be sure to see that the feed eccentric is set so there is no feeding movement. When adjustment has been made, securely tighten screw N2.

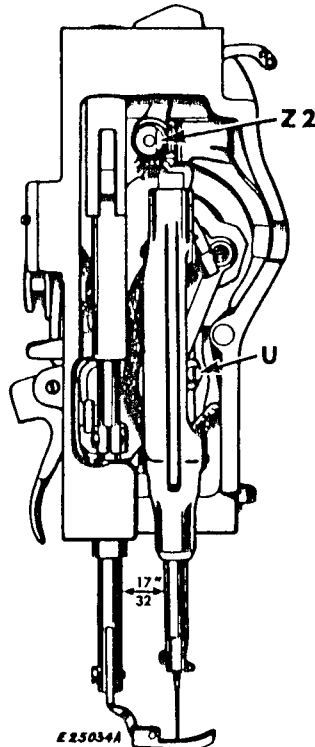

Fig. 15

TO SET THE SEWING HOOKS TO OR FROM THE NEEDLES

The points of the hooks should run as close to the needles (within the scarf) as possible.

Turn machine pulley over toward you until the points of the sewing hooks are at the centres of the needles. Loosen the four screws V,V and W,W, Fig. 16 underneath the bed of the machine.

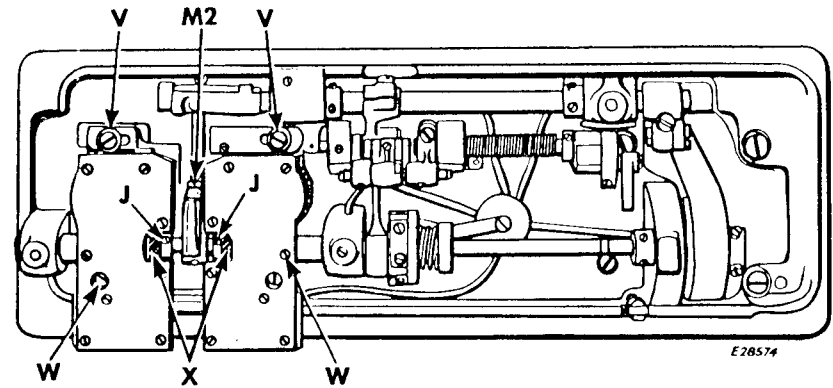

Fig. 16. Adjustments Underneath the Machine

Move the hook saddles to the right or left, as required. Securely tighten the four screws V,V and W,W.

CAUTION: Make sure hook driving gears X, Fig. 16 are set correctly with relation to face of hook saddle. Use .008 shim.

The function of the needle guard E2, Fig. 18 which is attached to the bottom of the sewing hook, is to prevent the point of the hook from striking the needle if, the needle is deflected toward the hook.

The needle guard can be bent with a small pair of pliers until it prevents the hook point from striking the needle, but it should not be bent outward enough to deflect the needle from its normal path.

TO TIME THE SEWING HOOKS

Adjust the feed eccentric to 8 stitches per inch.

Remove the Throat Plate and turn the machine pulley over toward you until the lower mark across the needle bar is just visible at the end of the needle bar frame on the upward stroke of the needle bar. If the needle bar and sewing hooks are correctly timed, the point of the right hook should be just even with the front on operator side of the right needle, and the point of the left hook should also be even with the front or operator side of the left needle.

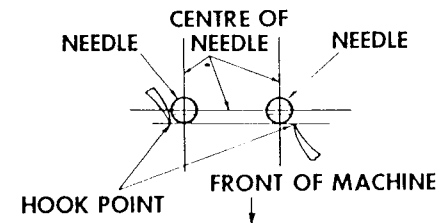

Fig. 16A

In case the sewing hooks are not correctly timed, turn the machine pulley over toward you until the needle bar has descended to its lowest point and has risen until the lower timing mark across the needle bar is just visible at the end of the needle bar frame. Loosen the two screws J, Fig. 16 in the hub of each hook and turn the hooks until the point of each hook is positioned as shown in Fig. 16A.

TO REMOVE BOBBIN CASES FROM SEWING HOOKS

Remove four hook gib screws **Y**, Fig. 17 from the sewing hooks. Lift off hook gibs, Fig. 18 and remove bobbin cases **A2**, Fig. 17.

CAUTION: Always equip this machine with chrome plated bobbin cases.

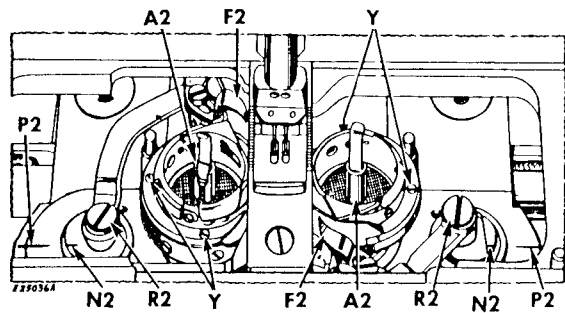

Fig. 17

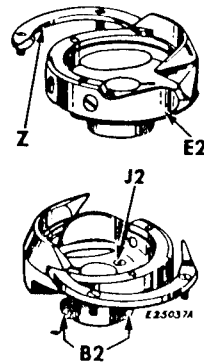

Fig. 18. Sewing Hook Removed from Machine Showing Hook Washer

TO REMOVE SEWING HOOKS FROM MACHINE

Remove presser foot, throat plate and feed dog. Loosen two Allen set screws **B2**, Fig. 18 in hub of hook and lift hook off end of shaft. To remove hook shaft, first remove screws in ball bearing retaining cap directly under the hook. Next, tip machine back and loosen set screws **C2**, Fig. 19 in hook shaft gears and lift hook shaft by top end. If shaft does not lift out easily, loosen screws in cover plate of hook saddle sufficiently to permit oil to drain out. Now, remove cover, being careful not to damage the gasket **D2**, Fig. 19 and tap end of hook shaft.

CAUTION: Each hook is equipped with a screw in the hub for adjusting the vertical position of the hook relative to the throat plate seat. When replacing or installing new hooks, care must be taken to see that the bobbin case stop finger fits correctly in the throat plate. If it is too high, it will interfere with the free passage of thread.

If it is too low, it is apt to slip out and cause damage to the hook and bobbin case when the machine is in operation. To make adjustment, remove the cloth washer in the bottom of the bobbin case. Loosen the Allen set screws in the hook hub. Turn the hook until the adjusting screw appears beneath one of the holes in the bottom of the bobbin case. Hold the hook down against its seat with one hand, and with the other hand, turn the adjusting screw with screwdriver until the proper up and down position is attained. Tighten Allen set screws in hub of hook.

To remove the ball bearing from the hook shaft, rest bearing on two pieces of sheet metal across the open jaws of a vise with the shaft end up. Tap shaft until bearing is removed.

TO ADJUST THE BOBBIN CASE OPENER

The bobbin case opener **F2**, Fig. 17 should be set so it touches the bobbin case as lightly as possible, yet turns the bobbin case enough to make a sufficient opening for the free passage of thread between the throat plate and the bobbin case.

TO ADJUST TIMING OF BOBBIN CASE OPENER

Turn machine pulley over toward you until lowest timing mark on needle bar is even with end of needle bar frame. In this position, the mark **N2**, Fig. 17 on the flange of the opener driving shaft, should line up with the reference mark **P2**, Fig. 17 on hook saddle. If opener shaft is out of time, tip machine back and loosen set screws **Q2**, Fig. 19 in opener driving gears. Return machine to up right position and turn shaft with screwdriver in screw **R2**, Fig. 17 at top end of shaft. Tighten set screws **Q2**, Fig. 19 in gears.

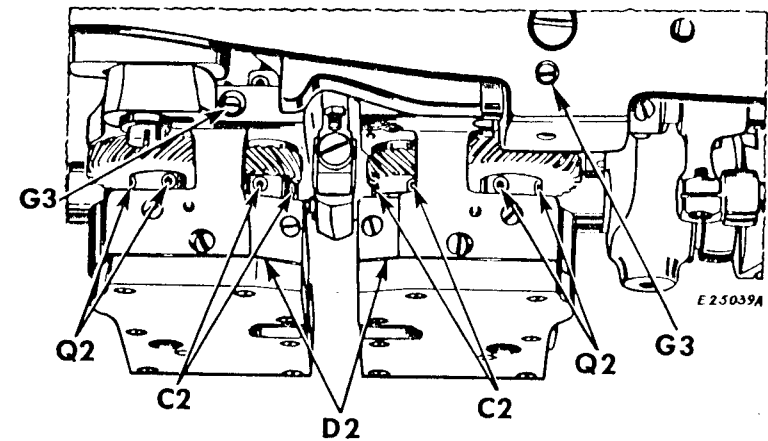

Fig. 19

TO ADJUST THE FEED ROCK SHAFT BEARINGS

The feed rock shaft is carried in split bushings which can be adjusted to take up any wear which may occur. Loosen the two lock screws **G2** and **H2**, Fig. 25 and turn in the two adjusting screws **J2** and **K2**, Fig. 25 until all lost motion of the rock shaft has been eliminated. Securely tighten the lock screws **G2** and **H2**.

TO RAISE OR LOWER THE FEED DOG

Usually when the feed dog is at its highest position, it should show a full tooth above the throat plate.

Remove the throat plate; clean the lint and dust from between the feed points and replace the throat plate. Tip the machine back and turn the machine pulley toward you until the feed dog is at its highest position. Loosen screw **M2**, Fig. 16 in the feed lifting cam fork and, as required, raise or lower the feed dog. Retighten the screw **M2**.

When raising or lowering the feed dog, be careful that its underside does not drop low enough to strike the sewing hooks.

The feed dog should be set so that when the needles are down they will be slightly in front of the centre of the needle holes (toward the operator). In case the needles do not enter the holes in the feed dog correctly, loosen the pinch screw **S2**, Fig. 25 and, as required, adjust the feed dog. Securely tighten the pinch screw **S2**, and check the relative position of the needle and presser bars as instructed on page 14.

TO REMOVE THE NEEDLE BAR ROCK FRAME

Open face plate, remove take-up hinge stud and take-up; see page 19. Remove cover plate on the front upright portion of the arm. Loosen needle bar rock frame rock shaft connection pinch screw **N2**, Fig. 20. Pull needle bar rock frame with its shaft from machine.

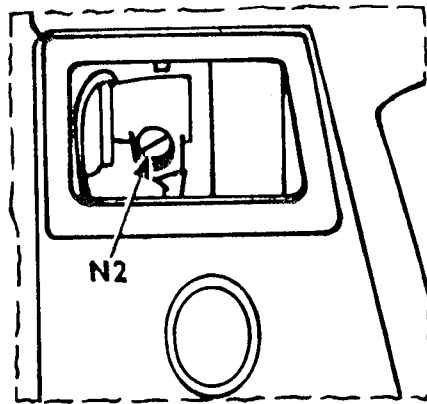

Fig. 20

THE FEED ECCENTRIC

The feed eccentric is provided with a gib **T2**, Fig. 21 which can be adjusted to take up any wear or loose motion between the feed eccentric and the eccentric body. To adjust the gib, loosen the two locking screws **U2**, Fig. 21 nearest the gib. Turn in the two adjusting screws **V2** against the gib until all play is eliminated and the eccentric fits snugly in the slot in the eccentric body. Securely tighten the two locking screws **U2**.

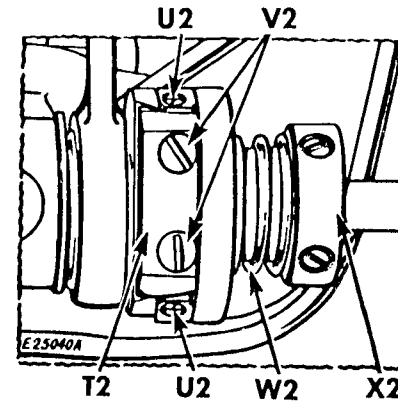

Fig. 21. Feed Eccentric

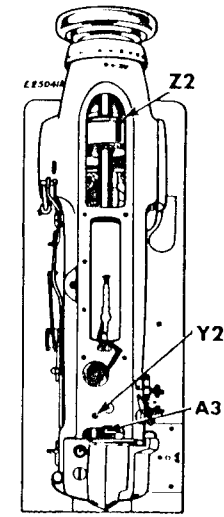

Fig. 22

The spring **W2** presses against the feed eccentric cam to prevent it from moving out of position while the machine is operating. The collar **X2** may be moved to the right or left to change the spring pressure. It should ordinarily be set flush with the end of the hub of the eccentric body.

TO REMOVE TAKE-UP LEVER

Remove arm top cover, and loosen set screw **Y2**, Fig. 22. Remove take-up lever hinge stud **Z2**, Fig. 15. Lift take-up lever out through slot in top of arm **A3**, Fig. 22.

TO REPLACE THE ARM SHAFT CONNECTION BELT

Remove needles to avoid damaging while machine is out of time. Slide belt off lower pulley **B3**, Fig. 23. Loosen two screws in the machine pulley. Remove machine pulley and ball bearing which comes out with the wheel. Lift belt up and draw it around the arm shaft through the space normally occupied by the ball bearing.

Replace belt through the ball bearing hole. After placing belt over the upper pulley **Z2**, Fig. 22, replace the machine pulley. To remove all end play from shaft, lightly tighten set screws in machine pulley and, holding needle bar crank in place, tap ma-

chine pulley into position with palm of hand. Tighten screws firmly. Turn machine pulley over toward you until thread take-up lever is at highest point. Turn the hook driving shaft until arrow **B3**, Fig. 23 on the belt pulley is in line with mark **C3**, Fig. 23 on the bed. Now, without disturbing either the arm shaft or hook driving shaft, slip the belt over the lower pulley. The feed will then be correctly timed with the needle.

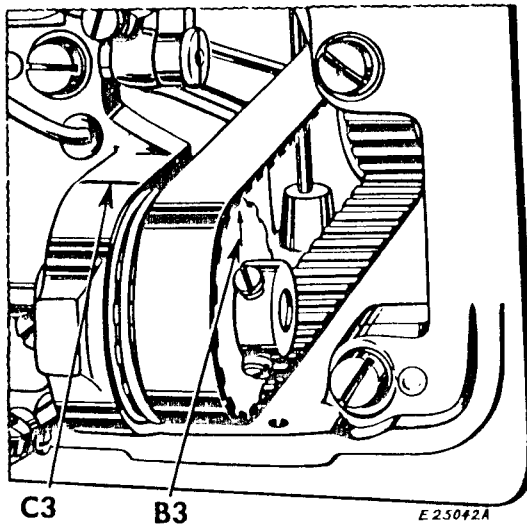

Fig. 23

CAUTION: DO NOT PINCH BELT in handling, as this will put a permanent kink in the wire reinforcements. Store in a cool, dark place until installed.

TO ADJUST THE FEED REVERSING MECHANISM

MACHINE 212 G 141 ONLY

The feed reversing mechanism bracket is set and pinned at the factory and should never be removed or adjusted. To set the mechanism to produce stitches of equal length in forward or reverse, loosen set screw **D3**, Fig. 24. Then position the crank **E3**, Fig. 24 by trial or error, until desired results are obtained. Tighten screw **D3** after each resetting. The machine can also be made to make a longer or shorter stitch in reverse than forward by the same method.

The Same!

To get replacements that are the same as parts in new machines...

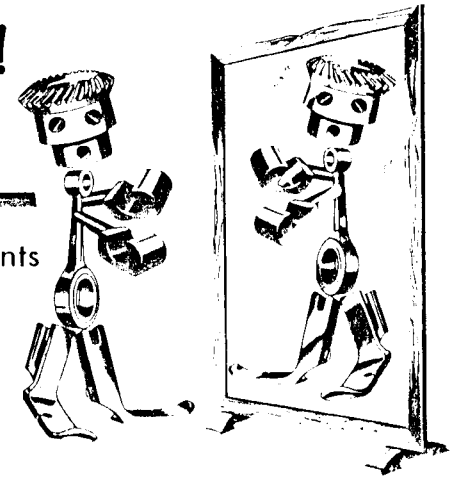

**BUY PARTS AND
NEEDLES MADE BY SINGER***

TO BE DOUBLY SURE...

of new machine performance, make sure that all replacement parts and needles are precisely identical to those in new SINGER machines.

Look for the trademark

SINGER

- ① on every package or container
- ② on the needle or numbered part

Needles in containers marked "For Singer Machines" are NOT made by SINGER.

TO ALL WHOM IT MAY CONCERN:

The improper placing or renewal of the Trademark "SINGER" or any other of the Trademarks of The Singer Company (all of which are duly Registered Trademarks) on any machine that has been repaired, rebuilt, reconditioned, or altered in any way whatsoever outside a SINGER factory or an authorized SINGER agency is forbidden.