

SINGER
81B6

1. DESCRIPTION

Model 81B6 Machine is a single needle, three thread overedge sewing machine recommended for overedging various types of knit wears such as sweaters, sweatshirts, jersey and woolen apparels etc.

For best sewing results, we suggest you take a few moments to read through this operator's guide as you sit at your new machine.

2. SPECIFICATIONS

- Maximum recommended speed: 3,000 RPM depending on material being sewn
- Stitch length: 1.5–3.2mm
- Stitch width: 2.5–3.8mm
- Maximum sewing capacity of material thickness: 4mm
- Needle: Cat. No. 6120-01, size #7–#14
- Motor: 1/3HP
- Size of machine: Approx. 250 × 210 × 270mm (including machine base)
- Net weight: Approx. 13 kg.

CAUTION:

- Be sure to turn off the power switch when changing the needle, presser foot, throat plate, or movable and stationary knives.
- Be sure to turn off the power switch when cleaning your machine.

HOW TO OPEN COVERS

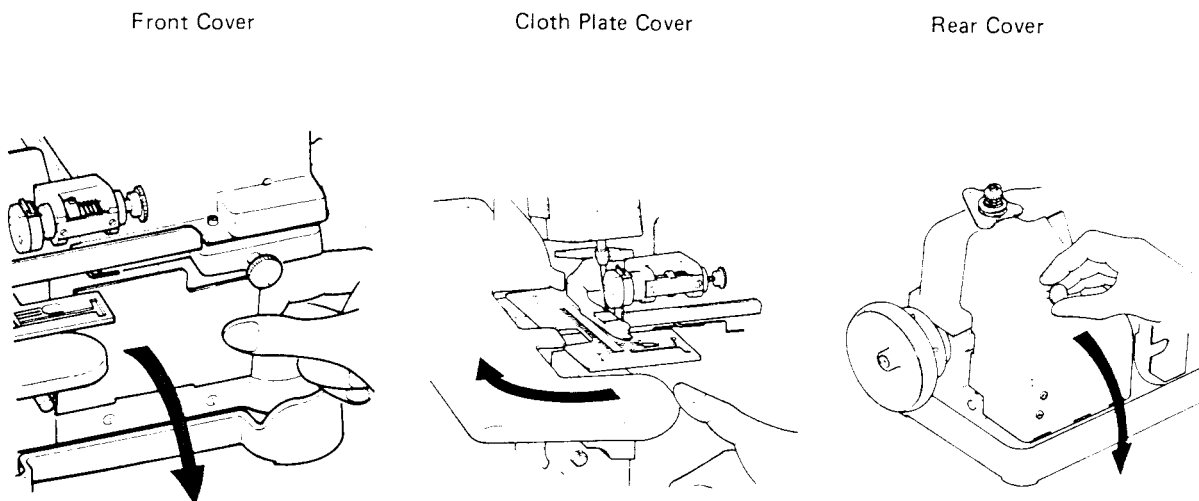

Fig. 1

3. LUBRICATION (See Figs. 2--4)

Oil your machine! For best results, use Single Type "D" oil.

When a machine is new or has been idle for several weeks, it is advisable to apply oil to all oiling points indicated in Figs. 2, 3 and 4 and to all other parts which are in movable contact. Run machine at a moderate speed for 10 to 15 minutes until all parts are fully lubricated.

A machine in continuous use should be oiled at least twice every day especially when the machine is operated at maximum recommended speed.

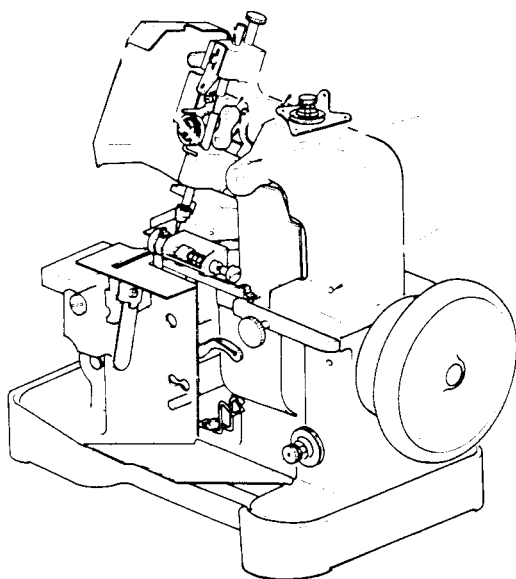

Fig. 2

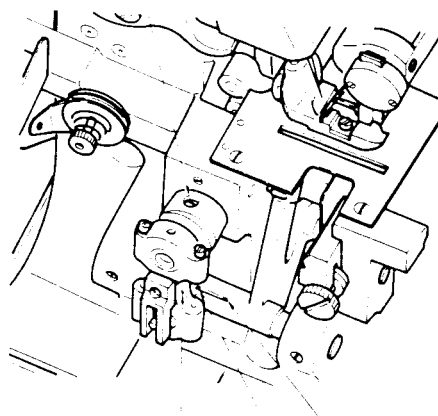

Fig. 3

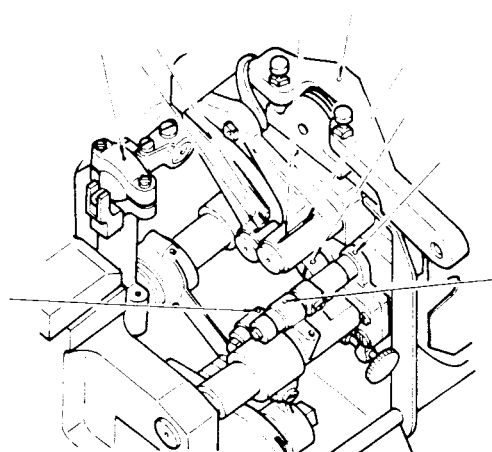

Fig. 4

4. SPEED

The maximum speed recommended for this machine is 3000 revolutions per minute.

Maximum efficient speed depends on the nature of operation and the type of material being sewn.

Never run a new machine at maximum speed immediately after installation. A speed of 2500 r.p.m. is recommended for the first 100 hours of operation.

5. NEEDLES AND THREADS

Size of needle is determined by size of thread used and type of material to be sewn. A correct size needle will permit the thread to pass freely through the eye of needle and avoid strain and breaking.

Use needle Cat. No. 6120-01, sizes 7–11 for sewing lightweight fabrics, sizes 11–14 for sewing medium weight fabrics and sizes 14–16 for sewing heavy weight fabrics.

Refer to following fabric, Thread and Needle Chart for guidance in selecting correct size needle and thread for your fabric.

6. FABRIC, THREAD AND NEEDLE TABLE

FABRIC	THREAD SIZE	NEEDLE SIZE
Light Weight – Jersey, Organdy, Voile, Taffeta, Fine Silk and Satin	80 to 120 Cotton 60 to 80 Silk 80 Synthetic Thread	Cat. 6120-01 #7 – #11
Medium Weight – Gingham, Pique, Linen, Cotton, Fine Corduroy, Cotton, Velvet, Twill and Khaki Drill	50 to 60 Cotton 40 to 50 Silk 50 to 60 Synthetic Thread	#11 – #14
Heavy Weight – Gabardine, Tweed, Denim, Vinyl, Corduroy, etc.	30 to 50 Cotton 30 to 50 Silk 50 Synthetic Thread	#14 – #16

7. TO SET NEEDLE (See Fig. 5)

1. Turn hand wheel away from you until needle bar is at its highest position.
2. Loosen needle clamping nut (2) with wrench (1) supplied with the machine.
3. Insert needle up into needle bar as far as it will go with the long groove to the front facing you.
4. Firmly tighten the needle clamping nut (2).

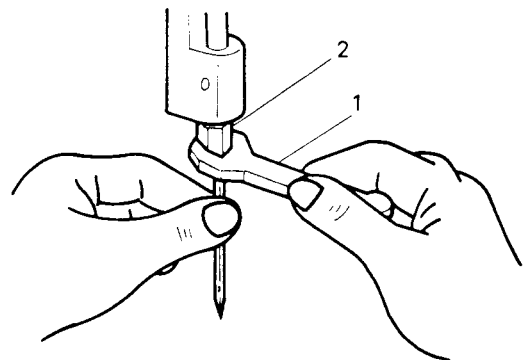

Fig. 5

8. TO THREAD THE NEEDLE (See Fig. 6)

Pass the thread from the unwinder down through the top hole (1) in the tension bracket, from back to front through the lower hole (2), from right to left around between the tension discs (3), through the hole (4), from front to back through the thread eyelet (6), down to the right of the pin (7) on the thread retainer, around the left side between the retainer discs (8), down into the guide (9), and from front to back through the eye of the needle.

When light needle thread tension is required to sew stitches such as type 505, the thread should be led from back to front through the hole (5) in the thread (needle) take-up after passing through the hole (4) in the tension bracket and before passing through the thread eyelet (6). Draw about 50mm of thread through the needle eye with which to start sewing.

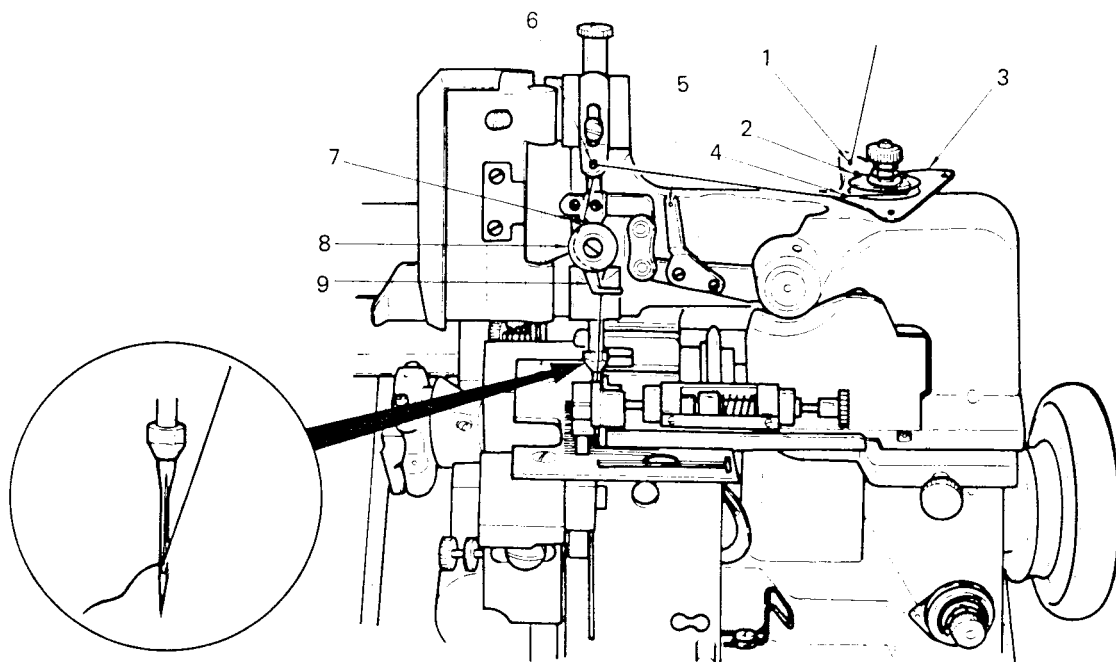

Fig. 6

9. TO CHANGE THE STYLE OF STITCH

To make the three-thread stitch or stitch type 504 (single purl stitch) shown in Fig. 7, using two loopers, the needle thread is drawn tightly to the goods, making a firm seam when two pieces are stitched together, and a very narrow bight can be used without danger of the seam pulling out. When adjusting the machine for this stitch, the needle thread is threaded in the regular way, and a tight tension is used.

The take-up on the looper lever at the left is set to the right so as to draw all the thread on the downward stroke, and the tension on the left hand looper thread is made light. Sufficient tension is used on the right hand looper thread to bring the purl to the edge.

To make a double purl stitch or stitch type 505 (Fig. 8), the needle thread is also threaded through the take-up in addition to the regular threading. The needle thread take-up is set so as to draw most of the thread on the downward stroke and a medium or light tension used.

The small take-up on the looper lever should be set as far as it will go to the left. Medium tension is used on the left hand looper thread. The right hand looper thread must be strong enough to bring the purl to the edge.

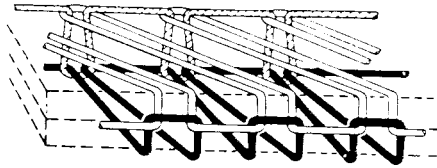

Fig. 7 Stitch Type 504

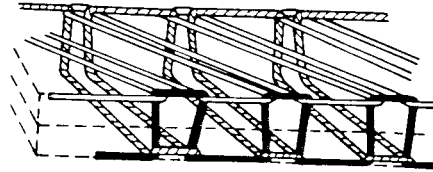

Fig. 8 Stitch Type 505

10. TO THREAD THE LEFT HAND LOOPER (See Fig. 9)

Turn hand wheel away from you until the needle bar has risen to its highest position.

Pass the thread from the unwinder through thread guide, from back to front through hole (1) in the lower cover, from back to front through hole (2) in lower tension bracket (3), up and over between the tension discs (4), through the thread guide tube (5) by means of tweezers supplied with the machine, through hole (6) in the thread hook, and while holding the thread end with the tweezers, turn hand wheel away from you until the needle bar descends to its lowest position, then pass the thread from back to front through hole (7) in the heel of the left hand looper (8) and from front to back through hole (9) near its point. Draw about 50mm of thread from the looper eye.

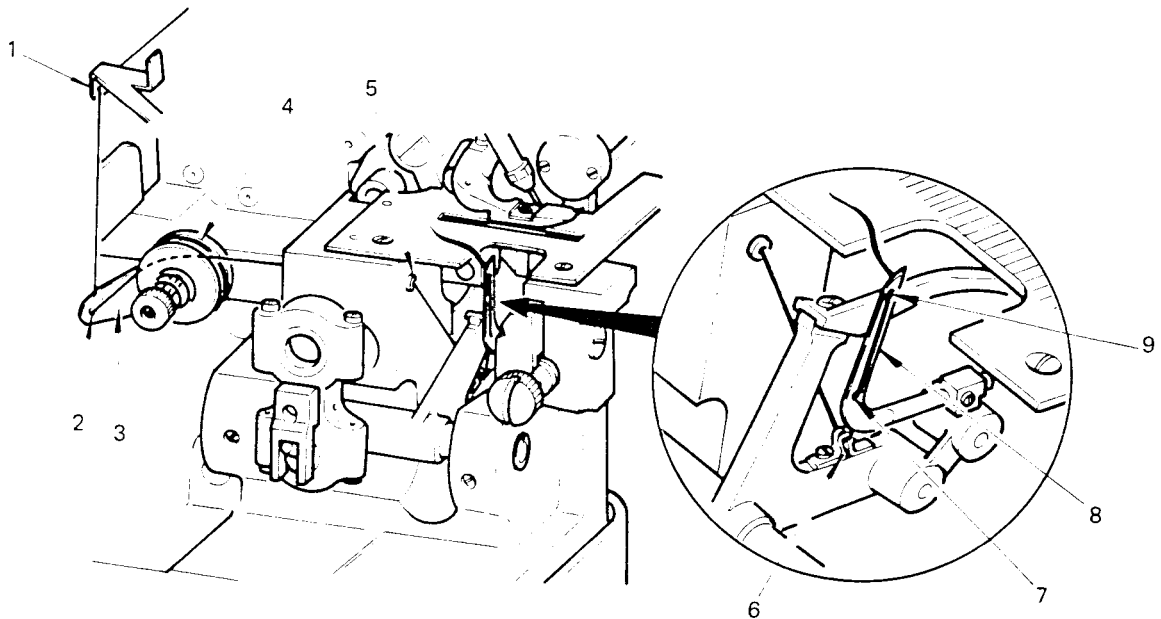

Fig. 9

11. TO THREAD THE RIGHT HAND LOOPER (See Fig. 10)

Open front cover (1). Turn hand wheel away from you until needle bar rises to its highest position.

Pass the thread from the unwinder through thread guide, down through hole (2) in the upper tension bracket (3), down through hole (4) in the knife guard bracket (5), down the right side of the tension stud (6) between the tension discs (7), to the left through hole (8) in the lower tension bracket, from back to front under the rear hook (9) of the thread guide, up and from back to front through hole (10) in the thread take-up, down and from back to front under the front hook (11). Turn hand wheel away from you and bring needle bar to its lowest position. Continue to pass the thread from the front hook up and from back to front through hole (12) in the heel of the right hand looper (13) and from front to back through hole (14) near its point. Draw about 50mm of thread from the looper eye.

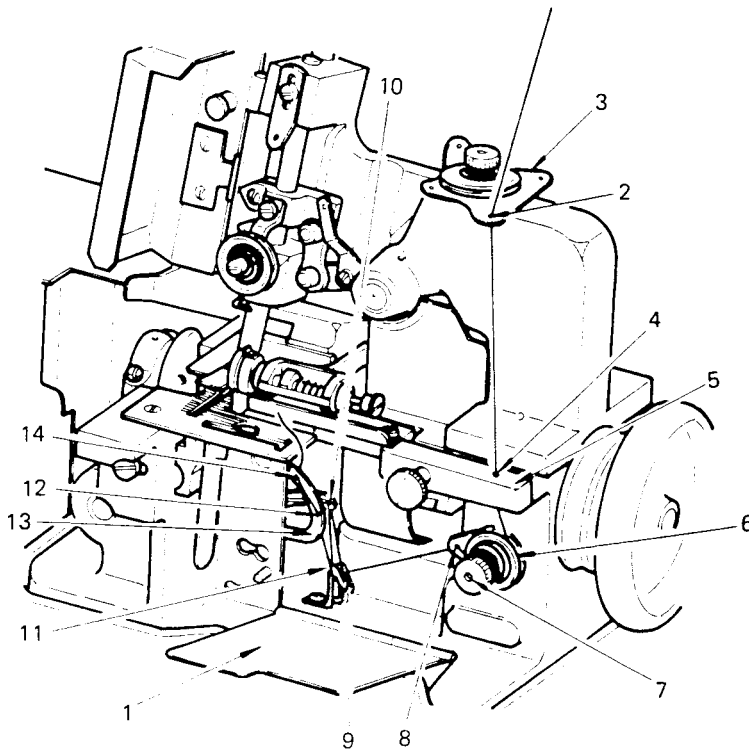

Fig. 10

12. CHAIN-OFF AND TEST SEW

When machine is completely threaded, turn the hand wheel away from you 2 or 3 turns while holding the 3 threads applying a slight tension. Make a test sample on a piece of your fabric so that you can adjust the thread tensions collectly.

When seam is completed, chain-off approximately 50mm and cut the thread with a pair of scissors.

13. TO ADJUST THREAD TENSIONS (See Figs. 11–13)

Adjust thread tensions to suit the fabric and size of thread used. Be sure the threads are correctly threaded otherwise proper thread tensions cannot be obtained.

When the thread tensions are correctly adjusted, a stitch formation as shown in Fig. 11 can be obtained.

The right hand looper thread will lie on the underside of the fabric when right hand looper thread tension is too loose, or left hand looper thread tension is too tight. Turn tension regulating nut (1) clockwise to increase the right hand looper thread tension, or turn tension regulating nut (2) counterclockwise to decrease the left hand looper thread tension.

When left hand looper thread appears on top of the fabric, either the left hand looper thread tension is too loose, or the right hand looper tension is too tight. Turn tension regulating nut (2) clockwise to increase left hand looper thread tension, or turn regulating nut (1) counterclockwise to decrease the right hand looper thread tension.

If satisfactory overedge stitches cannot be obtained even after making the above adjustments, adjust needle thread tension by turning the tension regulating nut (3) clockwise to increase the tension, or counterclockwise to decrease the tension.

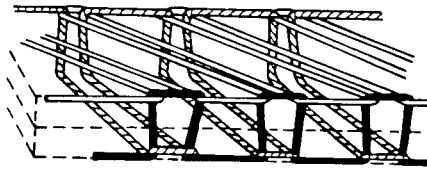

Fig. 11

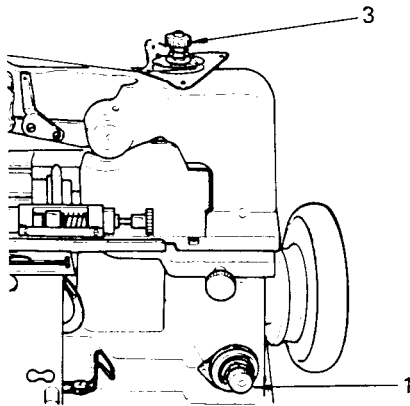

Fig. 12

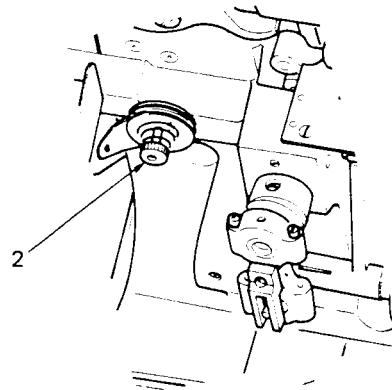

Fig. 13

14. TO REGULATE THE STITCH LENGTH (See Fig. 14)

The stitch length can be adjusted to suit the type of fabric being sewn within the specified range of 1.5–3.2mm.

1. Turn hand wheel away from you until the needle bar is at its highest position.
2. Loosen the stitch regulating screw stud (1) with the wrench supplied with the machine. (See Fig. 14)
3. Move screw stud (1) together with feed lifting link (2) along the slot in the feed regulator.
4. Move screw stud (1) outward for longer stitch and inward for shorter stitch.
5. Firmly tighten screw stud (1) when desired stitch length have been obtained.

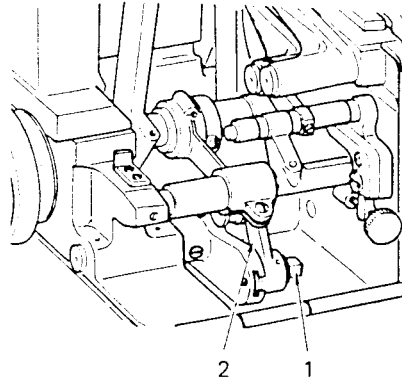

Fig. 14

15. TO ADJUST THE STITCH WIDTH (See Fig. 15)

The stitch width can also be adjusted to suit the fabric being sewn within the specified width of 2.5–3.8mm.

1. Loosen the thumb screw (1) holding the knife guard bracket (2) (see Fig. 15) and slide knife (2) with knife guard (3) to the right.
2. Loosen set screw (4) and turn adjusting screw (5) with fingers to move the stationary knife holder to the left or right as required and tighten the set screw (4). When a wider overedge seam is desired, move the holder to the right and when a narrower seam is desired, move the holder to the left.
3. Move knife guard bracket (2) to the left until the knife guard (3) is lightly in contact with movable knife (6) and tighten thumb screw (1).
4. Loosen screw (7) holding the chaining-off finger on the presser foot and adjust the finger in relation with the cutting width by moving it either to right or left and tighten screw (7).
5. Make a test sample and be sure the chaining-off finger is correctly positioned. Readjust if necessary.

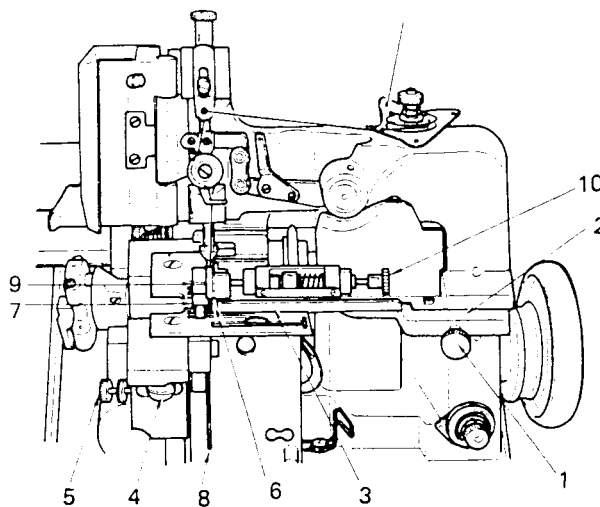

Fig. 15

16. TO ADJUST THE PRESSER FOOT PRESSURE

The presser foot pressure regulating screw regulates the presser foot exerts on the fabric.

The pressure on the fabric should be as light as possible while still sufficient to ensure proper feeding. Generally, heavy fabric requires heavy pressure and lightweight fabric, light pressure.

- To increase pressure. turn screw clockwise.
- To decrease pressure. turn screw counterclockwise.

17. TO REPLACE THE KNIVES (See Fig. 16)

The movable and stationary knives should be sharpened or replaced with a new one when they become dull.

To Remove the Knives

1. Loosen thumb screw (1) and slide knife guard bracket (2) to the right as far as it will go.
2. Move movable knife (6) away from the stationary knife (8) by pushing movable knife holder cap (9), and while holding the movable knife in this position, loosen movable knife holder screw (10) and pull the movable knife (6) up and out of the machine. Return movable knife holder to its rest position.
3. Loosen the stationary knife position plate screw (5) and slide stationary knife (8) down and out of the machine.

To Replace the Knives

When replacing the sharpened or new knives, the stationary knife should be replaced first.

1. Insert stationary knife (8) into slot provided for it on the stationary knife holder. Position stationary knife (8) so that its cutting edge is flush with the surface of throat plate, and while holding the knife in this position, firmly tighten the stationary knife position plate screw (5).
2. Turn hand wheel away from you until the needle bar descends to its lowest position.
3. Move movable knife holder to the right by pushing the knife holder cap (9), and while holding the knife holder in this position, insert movable knife (6) into holder slot and position it so that its cutting edge overlaps the stationary knife (8) by 0.5mm, then tighten the movable knife holder screw (10) and return holder to its rest position.
4. Slide knife guard bracket (2) to the left until the knife guard (3) is lightly in contact with movable knife (6) and tighten thumb screw (1).

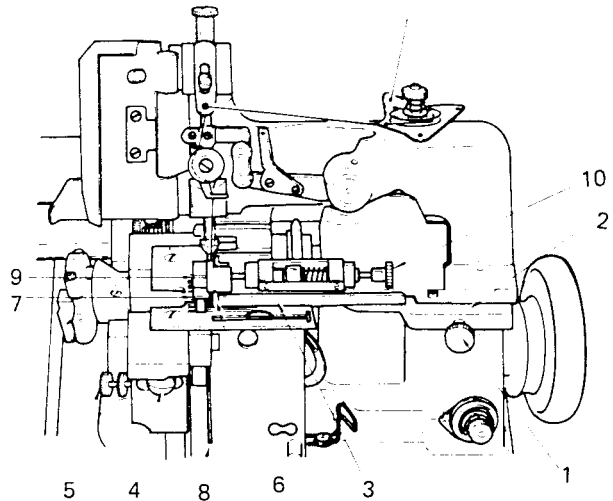

Fig. 16

18. PERFORMANCE CHECK LIST

Whenever sewing difficulty is encountered, make adjustments as instructed below.

Problems	Cause	Method of Adjustments
Irregular stitches	Unbalanced thread tensions. Lint accumulated around tension discs.	Adjust tensions Clean area around tension discs.
Skipped stitches	Needle bent or needle point damaged. Needle set loosely. Incorrect threading Incorrect needle size for thread being used. Insufficient presser foot pressure.	Replace with straight and sharp needle. Set needle firmly in position. Thread machine correctly. Use correct size needle for thread being used. Adjust presser foot pressure.
When fabric puckers	Thread tension too tight. Thread tangled or incorrectly threaded.	Adjust tensions. Thread correctly.
When fabric is not fed	Insufficient presser foot pressure.	Adjust presser foot pressure.
Thread breakage	Incorrect threading. Needle bent or needle point damaged. Thread tension too tight. Incorrect needle size. Needle inserted incorrectly.	Thread machine correctly. Replace with straight and sharp needle. Adjust tension. Replace with correct size needle. Insert needle correctly.
Needle breakage	Needle inserted incorrectly. Needle size incorrect for fabric and thread being used.	Insert needle correctly. Use correct size needle to suit fabric and thread used.