

INSTRUCTION MANUAL

FOR

SINGER 831U • 832U

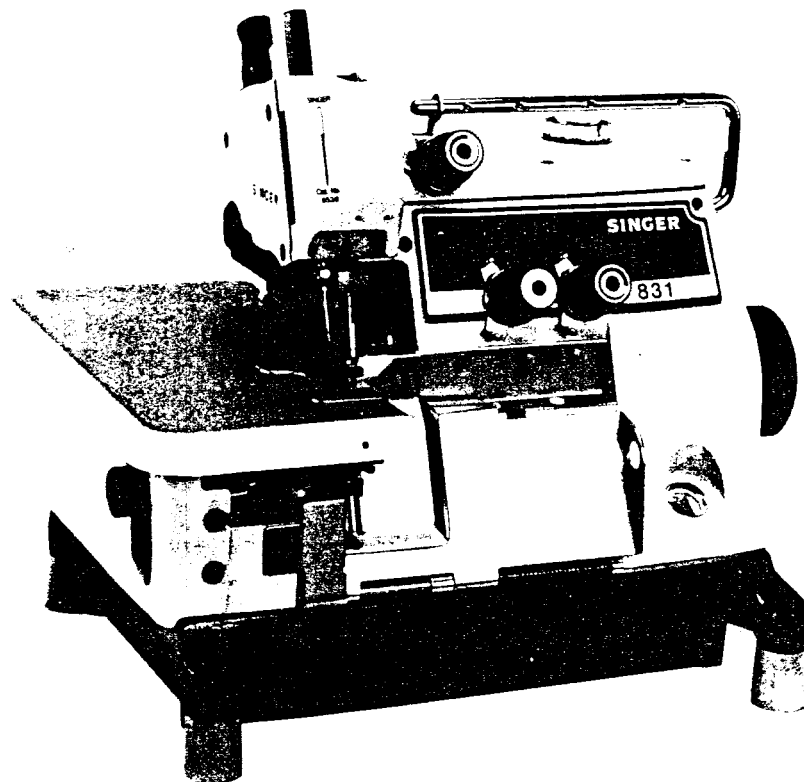

High Speed Single Needle Overedge Machine
Two Needle

THE SINGER COMPANY

CONTENTS

FEATURES	1
SPECIFICATIONS	2
A. INSTALLATION	5
1. Machine head installation	5
2. Sewing speed	5
3. Motor pulley and belt	5
4. Belt and belt cover installation	6
5. Thread unwinder installation	6
6. Eye guard installation	6
B. LUBRICATION	7
1. Type of oil	7
2. Lubrication and oil change	7
3. Needle cooler	7
C. OPERATION	8
1. Needle and thread	8
2. Setting needle	8
3. Threading	9
4. Thread tension	10
5. How to sew	12
6. Bight adjustment	12
7. Stitch length adjustment	13
8. Differential feed adjustment	13
D. STANDARD ADJUSTMENTS	14
1. Left hand looper and needle bar adjustment	14
2. Right hand looper adjustment	15
3. Knives adjustment	15
4. Feed dogs adjustment	15
5. Differential feed ratio adjustment	16
E. INSTALLATION AND ADJUSTMENT OF ATTACHMENTS	17
1. Blind hemming guide	17
2. Serging	17
3. Turn-down hemming	18
4. Taping	18
TROUBLESHOOTING GUIDE	19

FEATURES

1. Fully automatic lubricating system and needle cooler for reliable high-speed sewing.
2. Pushbutton controls permit easy adjustment of stitch length with a simple setting of the face plate scale.
3. Differential feed ratio can be easily adjusted with a lever.
4. Blade engaging angle can be easily adjusted for sharp cutting performance.

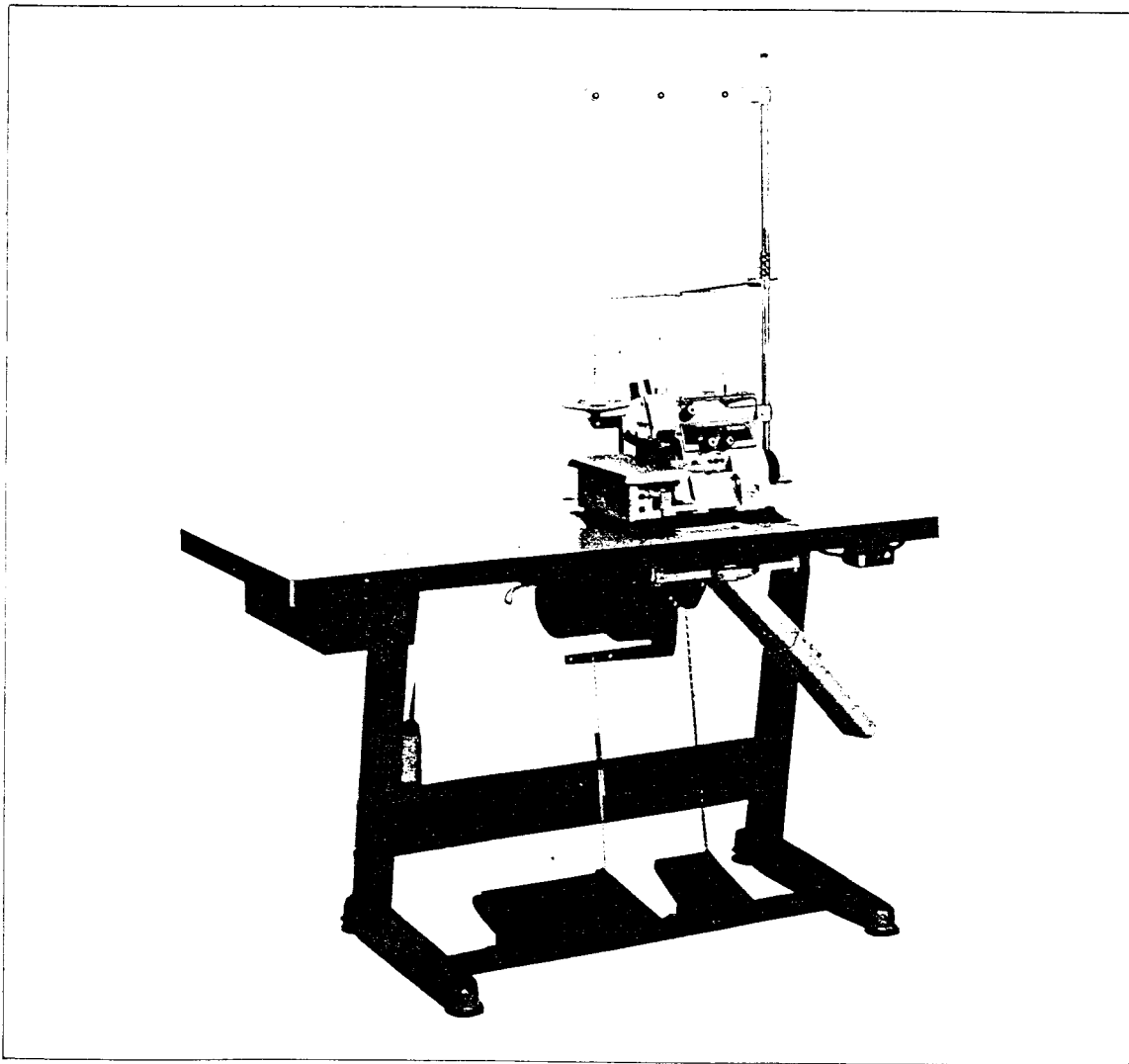

SPECIFICATIONS

THE SINGER COMPANY
831U
MADE IN JAPAN

Sub class No.	Stitch type	No. of Needles	No. of threads	Needle gauge (mm)	Bight (mm)	Max. stitch length (mm)	Differential ratio	Presser foot lift (mm)	Feed dog		Needle size (Cat.No. 6120)	Sewing speed (r.p.m.)	Use	Devices	
									Pitch (mm)	(Main) Type					
001-3 -4 -5 -6		1	3	-	3	3.6	0.6~1.8	6	1.6		#11	6500	Light & medium-heavy materials		-
					4								Knit underwear Knit shirts Sportswear	Setting sleeves Forming sleeves Joining body parts Joining inner leg edges	
					5										
					6										
002-5 -6 -7		1	3	-	5	2.5	1.3~4	7	2		#14	6000	Bulky knitwear		-
					6								Sweaters Cardigans Bulky sweaters	Setting sleeves Forming sleeves Joining body parts	
					7										
003-3 -4 -5		1	3	-	3	3.6	0.6~1.8	6	1.6		#9	6500	Blind-hemming		Blind hemming guide
					4								Knit underwear Knit shirts T-shirts	Blind-hemming	
					5										
004-3 -4		1	2	-	3	3.6	0.6~1.8	6	1.6		#9	6500	Blind-hemming		Blind hemming guide
					4								Knit underwear Knit shirts T-shirts	Blind-hemming	
005-4 -5 -6		1	2	-	4	3.6	0.6~1.8	4	1.6		#14	6000	Serging		Serging guide
					5								Trousers Skirts	Serging	
					6										
006-4 -5		1	3	-	4	3.6	0.6~1.8	4	1.6		#14	6000	Serging		Serging guide
					5								Trousers Skirts	Serging	
007-2 -4		1	3	-	2	3.6	0.6~1.8	6	1.6		#11	6500	Turn-down hemming		-
					4								Handkerchiefs Scarves		
008-5		1	3	-	5	3.3	1~3	5	1.6		#11	6000	Ruffling		Ruffler
													Ladies' & children's wear	Setting sleeves Setting cuffs Setting frills	
009-5		1	3	-	5	3.3	1~3	5	1.6		#11	6000	Ruffling (Piping)		Binder Ruffler Tape winder
													Ladies' & children's wear	Setting sleeves Setting cuffs Setting frills	
010-5		1	3	-	5	3.6	0.6~1.8	6	1.6		#11	6500	Taping light & medium-heavy materials		Tape guide
													Knit underwear Knit shirts T-shirts	Joining shoulder parts	

Sub class No.	Stitch type	No. of Needles	No. of threads	Needle gauge (mm)	Bight (mm)	Max. stitch length (mm)	Differential ratio	Presser foot lift (mm)	Feed dog		Needle size (Cat.No.)	Sewing speed (r.p.m)	Use	Devices	
									Pitch (mm)	(Main) Type					
011-6		1	3	—	6	2.5	1.3~4	7	2		#14	6000	Bulky knitwear taping		Tape guide
-7					7								Sweaters Cardigans, Bulky sweaters		
012-3		1	3	—	3	3.6	0.6~1.8	6	1.6		#11	6500	Chain-back		Chain-back Thread release
-4					4								Knit underwear Knit shirts Sportswear	Setting sleeves Forming sleeves Joining body parts Joining inner leg edge	
-5					5										
-6					6										

THE SINGER COMPANY
832U
 MADE IN JAPAN

Sub class No.	Stitch type	No. of Needles	No. of threads	Needle gauge (mm)	Bight (mm)	Max. stitch length (mm)	Differential ratio	Presser foot lift (mm)	Feed dog		Needle size (Cat.No.)	Sewing speed (r.p.m)	Use	Devices	
									Pitch (mm)	(Main) Type					
021-4		2	4	1.8	4	3.6	0.6~1.8	6	1.6		(8538) #11	6500	Light materials		—
-5					5								Knit underwear	Setting sleeves Forming sleeves Joining body parts Joining inner leg edges	
022-5		2	4	2.2	5	3.6	0.6~1.8	6	1.6		(6120) #11	6500	Light & medium-heavy materials		—
-6					6								Knit underwear Knit shirts T-shirts	Setting sleeves Forming sleeves Joining body-parts Joining inner leg edges	
023-5		2	4	2.2	5	3.6	0.6~1.8	6	1.6		(6120) #11	6500	Light & medium-heavy materials		—
-6					6								Dress shirts Blouses	Setting sleeves Forming sleeves Joining body sections	
024-5		2	4	3	5	3.6	0.6~1.8	6	1.6		(6120) #11	6500	Light & medium-heavy materials		—
-6					6								Knit underwear Knit shirts T-shirts	Setting sleeves Forming sleeves Joining body parts Joining inner leg edges	
025-6		2	4	3	6	3.6	0.6~1.8	6	1.6		(6120) #11	6500	Light & medium-heavy materials		—
-6					6								Dress shirts Blouses	Setting sleeves Forming sleeves Joining body sections	
026-4		2	4	1.8	4	2.5	1.3~4	7	1.6		(8538) #11	6000	Bulky knitwear		—
-5					5								Sweaters Cardigans Bulky sweaters	Setting sleeves Forming sleeves Joining body sections	
-6					6										

Sub class No.	Stitch type	No. of Needles	No. of threads	Needle gauge (mm)	Bight (mm)	Max. stitch length (mm)	Differential ratio	Presser foot lift (mm)	Pitch (mm)	Feed dog		Needle size (Cat.No.)	Sewing speed (r.p.m)	Use	Devices	
										(Main)	(Differential) Type					
027-5 -6 -7		2	4	2.2	5 6 7	2.5	1.3~4	7	2			(6120) #14	6000	Bulky knit wear Sweaters Cardigans Bulky sweaters	Setting sleeves Forming sleeves Joining body sections	-
028-5 -6 -7		2	4	2.2	5 6 7	2.5	1.3~4	7	2			(6120) #14	6000	Bulky knit wear Sweaters Cardigans Bulky sweaters	Setting sleeves Forming sleeves Joining body sections	-
031-7		2	4	3	7	3.6	0.6~1.8	7	2.5			(6122) #21	6000	Extra-heavy materials Denim wear Curtains Cushions	Run stitching Serging	-
032-7		2	4	3	7	3.6	0.6~1.8	7	2.5			(6122) #21	6000	Extra-heavy materials Denim wear Curtains Cushions	Run stitching Serging	-
033-5		2	4	2.2	5	3.3	1~3	5	1.6			(6120) #11	6000	Ruffling Ladies' & children's wear	Setting sleeves Setting cuffs Setting frills	Ruffler
034-5		2	4	2.2	5	3.3	1~3	5	1.6			(6120) #11	6000	Ruffling Ladies' & children's wear	Setting sleeves Setting cuffs Setting frills	Ruffler
037-5		2	4	2.2	5	3.3	1~3	5	1.6			(6120) #11	6000	Ruffling (with piping) Ladies' & children's wear Blouses	Setting sleeves Setting cuffs Setting frills	Binder Ruffler Tape winder
038-5		2	4	2.2	5	3.3	1~3	5	1.6			(6120) #11	6000	Ruffling (with piping) Ladies' & children's wear Blouses	Setting sleeves Setting cuffs Setting frills	Binder Ruffler Tape winder
041-5		2	4	2.2	5	3.6	0.6~1.8	6	1.6			(6120) #11	6500	Taping light & medium-heavy materials Knit underwear Knit shirts T-shirt	Joining shoulder parts	Tape guide
045-5 -6 -7		2	4	2.2	5 6 7	2.5	1.3~4	7	2			(6120) #14	6000	Bulky knit taping Sweaters Cardigans Bulky sweaters	Joining shoulder parts	Tape guide
049-5 -6		2	4	2.2	5 6	3.6	0.6~1.8	6	1.6			(6120) #11	6500	Chain-back Knit underwear Knit shirts Sportswear	Setting sleeves Forming sleeves Joining body parts Joining inner leg edges	Chain-back Thread release
050-5		2	4	2.2	5	3.6	-	5	1.6			(6120) #11	6500	Cover piping Sheet cover Bed cover	Run stitching Angular stitching	Binder Bracket assembly Binder Tape winder

A. INSTALLATION

1. Machine head installation

Parts for semi submerged installation are included in the accessories.

Install the machine head in the following order.

- (1) Fit four rubber cushions ❶ on base ❷.
(Install the black rubber cushion Ⓐ on the right end pin as shown.)
- (2) Place machine head ❸ on rubber cushions ❶.

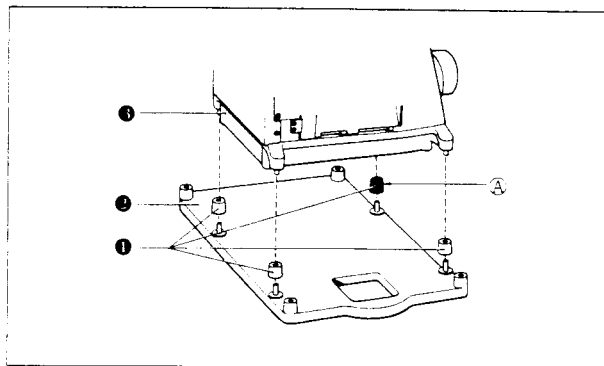

* If you have purchase this machine as head only, install it as mentioned below.

- (a) Make table top ❹ as shown in the attached table sheet.
- (b) Install base ❷ as shown at right.
- (c) Follow the above-mentioned order (1) and (2) for installing the machine head.

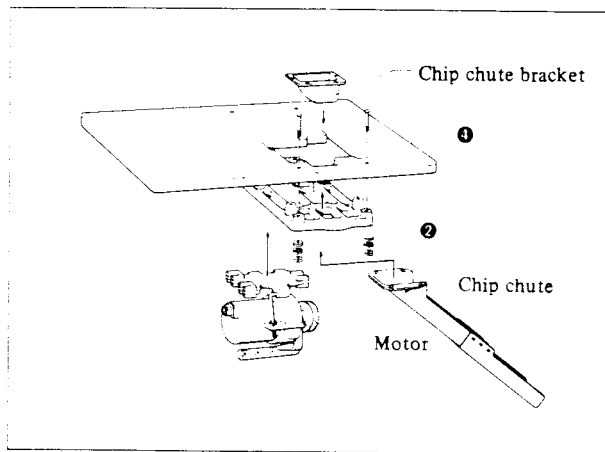

2. Sewing speed

For the sewing speed of your machine, refer to the "SPECIFICATIONS" on pages 2 ~ 4.

When using new machine for the first time, operate it at about 5,500 revolutions per minute for the first 100 hours.

3. Motor pulley and belt

The motor to be used with this machine must be a 2-pole, 400W, clutch motor. Use a M-type V-belt.

Select a motor pulley and a belt by referring to the table at right.

Pulley O.D.(mm)	90	95	100	105	110	115	120	125	130	135	140	
Belt size (inches)	<div style="display: flex; justify-content: space-between; align-items: center;"> <div style="width: 10%;"></div> <div style="width: 40%; text-align: center;">(36)</div> <div style="width: 10%;"></div> <div style="width: 30%; text-align: center;">(37)</div> <div style="width: 10%;"></div> <div style="width: 10%; text-align: center;">(38)</div> </div>											
Sewing speed (rpm)	50Hz	-	-	-	-	5000	5500	6000	6500	-	-	-
	60Hz	5000	5500	6000	6500	-	-	-	-	-	-	

4. Belt and belt cover installation

Installing the belt

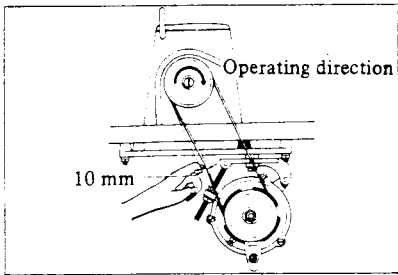

- (1) The belt should give about 10 mm when depressed with finger.
- (2) Operating direction is clockwise.

Installing the belt cover

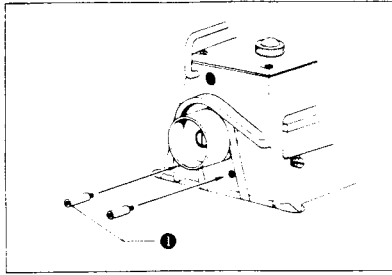

- (1) Install the stud 1 on the machine head.

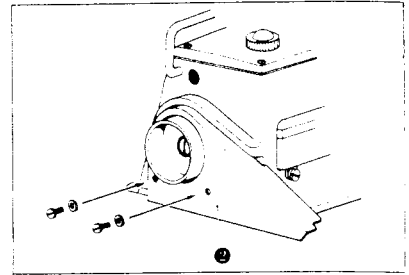

- (2) Install the belt cover 2 on the stud 1.

5. Thread unwinder installation

Install the thread unwinder in the far right corner of the table with screws, making sure that it will not interfere with machine operation.

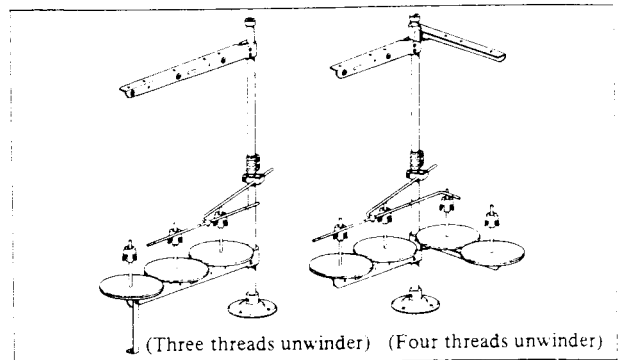

6. Eye guard installation

Install the eye guard 1 on the face plate cover 2.

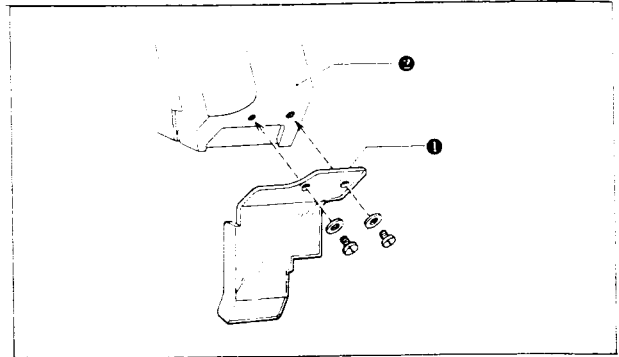

B LUBRICATION

1. Type of oil

Use the oil (viscosity 37.8°C SUS 70) supplied as accessory.

2. Lubrication and oil change

All oil has been drained from the machine prior to shipment. Before operating machine, remove oil cap ① by turning it counterclockwise, and pour the oil into the machine, using the accessory funnel.

Stop supplying the oil when the oil level has reached the upper reference line of the oil gauge as shown at right.

* Before using your machine, check the oil level to see that it is somewhere between the two reference lines.

Add oil if the level is below the lower reference line of the oil gauge.

When operating the machine for the first time after unpacking it, or after a long period of non-use, pour a few drops of oil on needle bar ② and right hand looper holder ③.

* If the machine is used every day, it need not be oiled daily.

Change the oil after 100 hours of running in.
After that period, change the oil about every 3 months.

* It is recommended that oil reservoir ⑤ be removed, and the inside of the oil reservoir, pump and filter be cleaned about twice every year.

When draining the oil, remove cap screw ④ as shown at right.

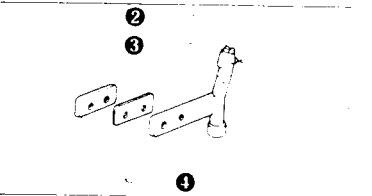
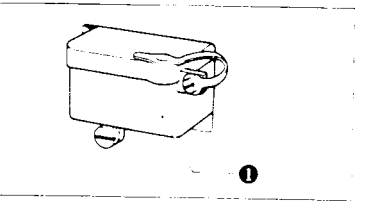
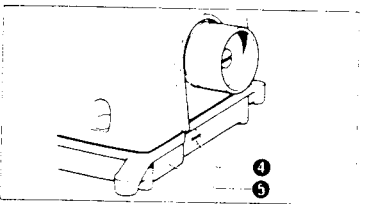
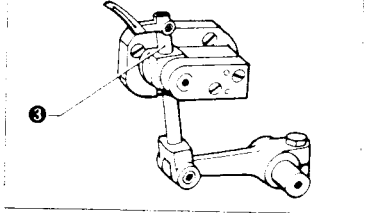
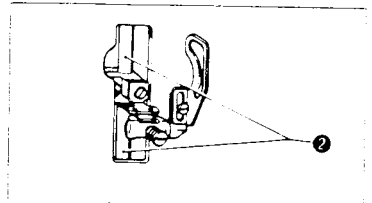
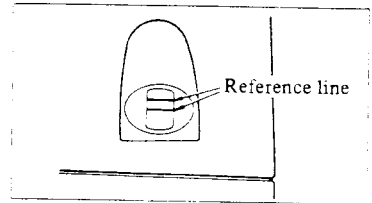
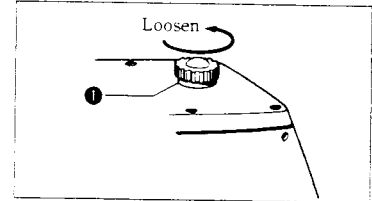

3. Needle cooler

Use the needle cooler when sewing synthetic fabrics or chemicalcoated fabrics, or when using synthetic threads.

(1) Oil to be used Silicone oil

(2) Directions for use

Fill tank ① (tank capacity: 30 c.c.) with the accessory silicone oil.

* When using the machine for the first time after unpacking it, or after a long period of non-use, pour a few drops of silicone oil on felt ② to make it wet. Then begin sewing.

* The two needle model 832U has spacers ④ (for 2 mm or 3 mm needle gauge) which are installed together with felt support ③.

C. OPERATION

1. Needle and thread

Select a needle and thread by referring to the tables below.

Single-needle, two-thread

Fabrics	Needle		Needle thread		Looper thread	
	Type	Size	Type	Size	Type	Size
Wool, Dacron, light materials, trouser fabric	Cat. No. 6120	#14	Cotton	#60/2	Cotton	#60/2
Wool, Dacron, medium-heavy materials, trouser fabric	"	#14	Cotton	#60/2	Cotton	#60/2
Knit materials jersey	"	#14	Textured nylon yarn	110/2 denier	Textured nylon yarn	110/2 denier

Single-needle, three-thread

Fabrics	Needle		Needle thread		Looper thread	
	Type	Size	Type	Size	Type	Size
Knit materials	Cat. No. 6120	# 9	Cotton	#60/2	Cotton	#60/2
	"	# 9	Synthetic thread	#60	Synthetic thread	#60
	"	#11	Synthetic thread	#60	Synthetic thread	#60
Light knit materials	"	#11	Textured nylon yarn	110/2 denier	Textured nylon yarn	110/2 denier
Heavy knit materials	"	#14	Synthetic thread	#50	Yarn	Very light
Knit materials (Blind-hemming)	"	# 9	Cotton	#60/2	Cotton	#60/2
	"	# 9	Textured nylon yarn	110/2 denier	Textured nylon yarn	110/2 denier

Two-needle, four-thread

Type of stitch	Fabrics	Needle		Needle thread		Looper thread	
		Type	Size	Type	Size	Type	Size
Two-needle Four-thread	Knit materials	Cat. No. 6120, 6122, 8538	# 9	Cotton	#60/2	Cotton	#60/2
	Light knit materials	"	#11	Synthetic thread	#60	Synthetic thread	#60
	Bulky knit	"	#14	Synthetic thread	#50	Yarn	Very light
Mock safety	Broad cloth	"	#11	Cotton	#80	Cotton	#80
	Jersey	"	#14	Dacron	#50	Dacron	#50

2. Setting needle

Turn the pulley until the needle bar is raised close to the highest position, press down presser bar lifter ①, and swing out presser arm ② in the arrow direction.

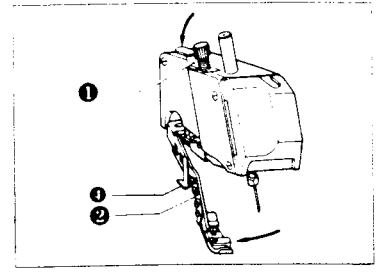

Loosen needle clamp nut ③, hold the needle with its recessed side facing back, insert the needle all the way into the needle clamp hole, and then tighten the needle clamp nut.

* In the figure at right, the numeral ③ on the right indicates the two-needle clamp screw.

Install trimming knife ④ on the main presser arm.

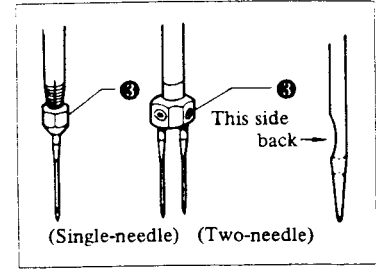

3. Threading

Before threading, open face plate cover ①, front cover ② and cloth plate ④, turn the pulley until the needle is raised up highest, and then swing out presser arm ③.

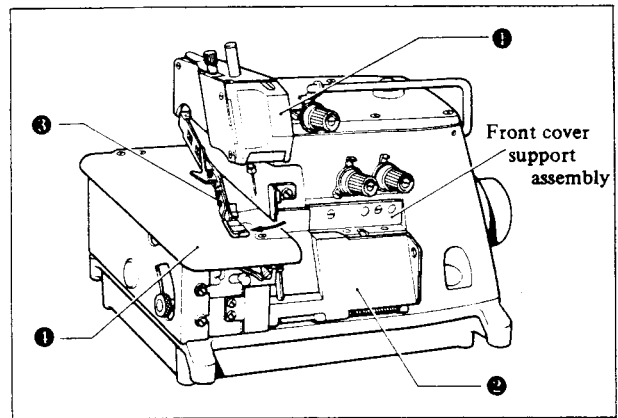

(1) 831U

In case of two-thread, pass left hand looper thread ① first and then needle thread ③ as shown at right.

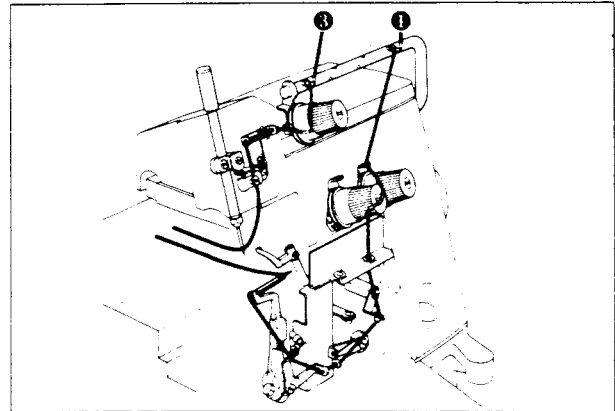

In case of three-thread, pass left hand looper thread ① first, right hand looper thread ② second, and finally needle thread ③ as shown at right.

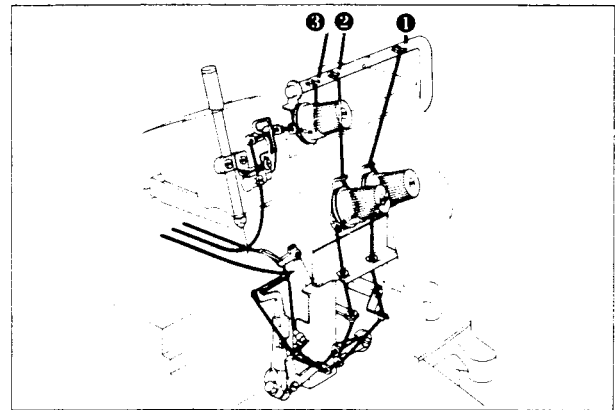

(2) 832U

In case of four-thread, pass left hand looper thread ① first, right hand looper thread ② second, needle thread ③ third and finally needle thread ④ as shown at right.

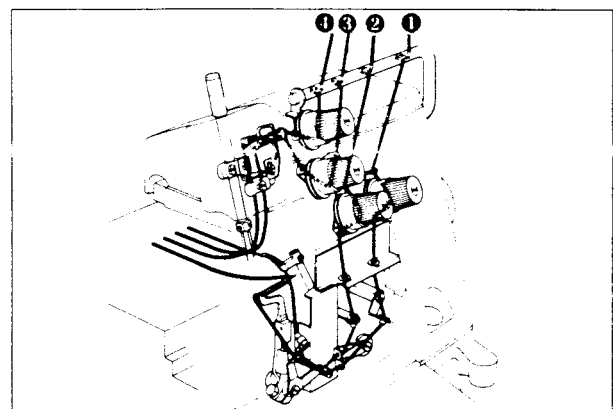

4. Thread tension

Thread tension may require change depending on fabrics and threads used, bight, stitch length, the position of each thread take-up, and the position of the thread guides. If necessary, adjust as mentioned below.

(1) Adjusting the overedge stitch needle thread take-up

To increase the thread tension, lower needle thread take-up ①. To decrease it, raise the thread take-up. The center position in the adjustable range is standard.

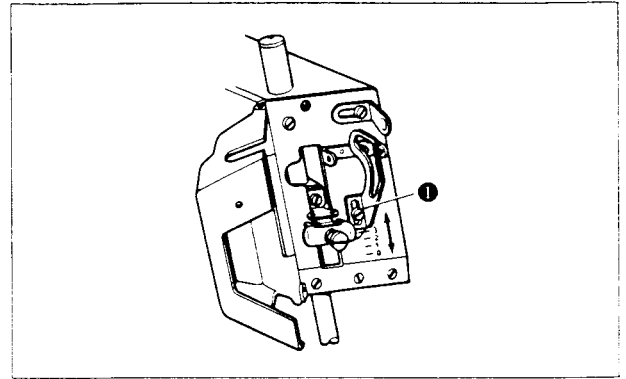

Use the thread take-up for two threads (A) or for three threads (B) as appropriate to your sewing purpose.

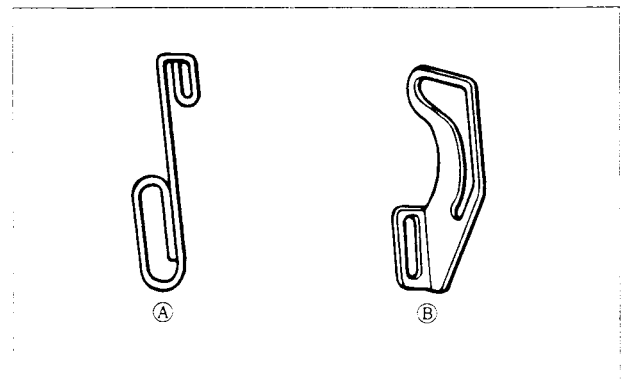

(2) Adjusting the overedge stitch looper thread take-ups and thread guides

The figure at right shows the standard positions of the looper thread take-ups and each thread guide when the needle bar is up highest.

More thread will be fed when looper thread take-ups right ③, ④ are raised; and less thread when they are lowered.

More thread will be fed when left hand looper thread guide ② is moved to the left; and less thread when it is moved to the right.

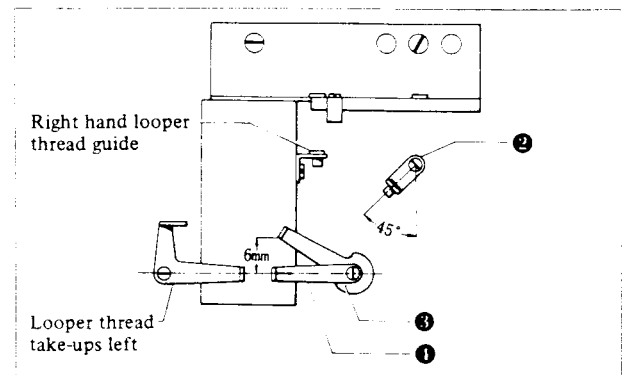

(3) Presser foot pressure adjustment

Adjust the presser foot pressure with presser foot adjusting screw ⑤.

Turn clockwise to increase the pressure, or counter-clockwise to decrease.

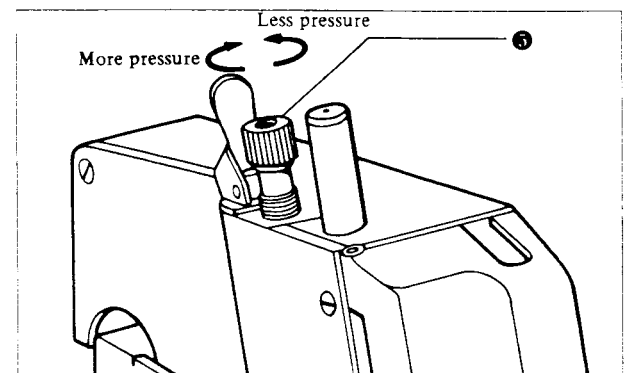

(4) Thread tension

Measure the thread tension as shown at below.

(Needle thread tension)

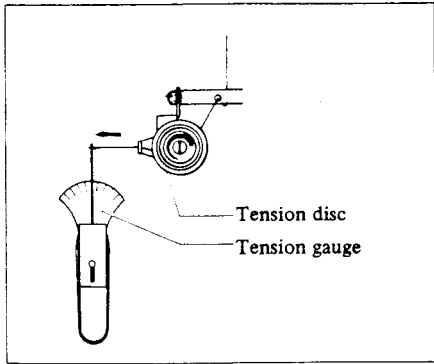

(Looper thread tension)

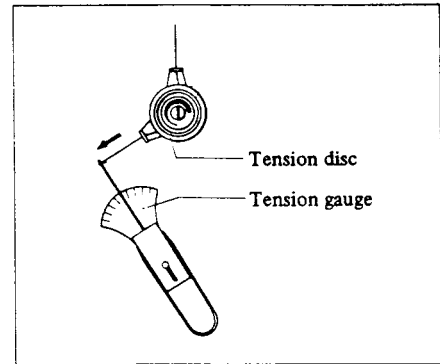

Adjust the tension of each thread by referring to the tables below (In grams).

(Single-needle, two-thread)

Fabrics	Thread		Needle thread tension (grams)	Looper thread tension (grams)
	Type	Size		
Wool, Dacron, light materials, trouser fabric	Cotton	#60/2	18~28	8~18
Wool, Dacron, medium-heavy materials, trouser fabric	Cotton	#60/2	18~28	8~18
Knit materials, jersey	Textured nylon yarn	110/2 denier	10~20	15~25

(Single-needle, three-thread)

Fabrics	Thread		Needle thread tension (grams)	Right hand looper thread tension (grams)	Left hand looper thread tension (grams)
	Type	Size			
Knit materials	Cotton	#60/2	43~73	6~22	6~22
	Synthetic thread	#60	40~70	4~18	4~18
Light knit materials	Synthetic thread	#60	40~70	4~18	4~18
	Textured nylon yarn	110/2 denier	30~50	4~15	4~15
Heavy materials	Needle: Synthetic thread Looper: Yarn	#50 Very light	50~80	4~15	4~15
Knit materials (Blind hemming)	Cotton	#60/2	15~25	8~15	22~32
	Textured nylon yarn	110/2 denier	10~20	2~10	6~18

(Two-needle, four-thread) Four-thread overedge

Fabrics	Thread		Left needle thread tension (grams)	Right needle thread tension (grams)	Right hand looper thread tension (grams)	Left hand looper thread tension (grams)
	Type	Size				
Knit materials	Cotton	#60/2	60~80	30~50	6~18	8~20
Light knit materials	Synthetic thread	#60	40~60	25~45	4~16	6~18
Bulky	Needle: Synthetic thread Looper: Yarn	#50 Very light	70~90	35~55	3~10	5~15

(Two-needle, four-thread) Mock safety

Fabrics	Thread		Left needle thread tension (grams)	Right needle thread tension (grams)	Right hand looper thread tension (grams)	Left hand looper thread tension (grams)
	Type	Size				
Broad cloth	Cotton	#80	50~80	45~70	8~15	8~15
Jersey	Dacron	#50	50~70	25~50	10~20	8~18

5. How to sew

Press the push button switch ON, depress presser bar lifter pedal ②, place the work under the presser foot, and release the presser bar lifter pedal.

When treadle ① is depressed, the work will be fed and sewn.

After sewing, run the machine without the work until about 5 or 6 cm of thread is out, and cut the trimming knife ③ by pulling the thread toward yourself.

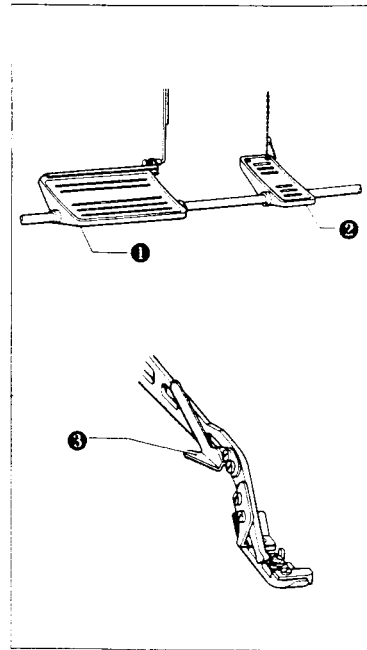

6. Bight adjustment

Bight depends on cloth trimming width and the width of the chain-off finger of the throat plate.

(1) To increase bight

- Loosen movable knife holder set screw ②, move knife holder ① to right as much as necessary, and retighten the set screw securely.
- Loosen stationary knife holder set screw ④, and make the stationary knife pushed against the movable knife by the stationary knife holder spring, lower the movable knife close to its lowest position and retighten the stationary knife holder set screw.

(2) To decrease bight

- Loosen the stationary knife holder set screw, move knife holder ③ to left as much as necessary, and temporarily tighten the set screw.
- Loosen the movable knife holder set screw, move the knife holder until the movable knife contacts the stationary knife, and retighten the set screw securely.
- Loosen the screw temporarily tightened in step (a), make sure that the stationary knife is pressed against the movable knife by the stationary knife holder spring, lower the movable knife close to its lowest position, and retighten the set screw securely.

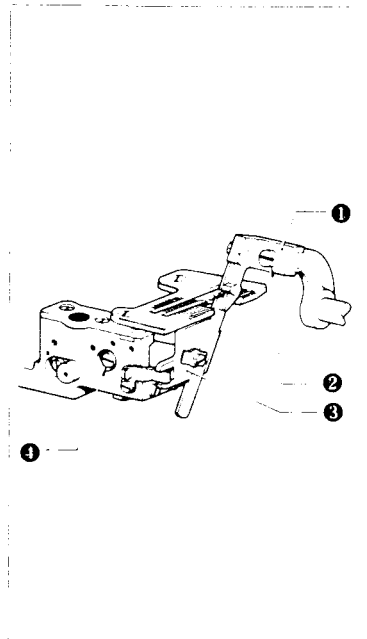

[Caution]

- Since bight depends on cloth trimming width and the width of the throat plate's chain-off finger, cloth trimming width must be changed at the same time in case of changing bight by more than 1 mm.
- If the knife cutting performance has dropped, sharpen the stationary knife as shown at right.

The movable knife cannot be sharpened with an ordinary whetstone.

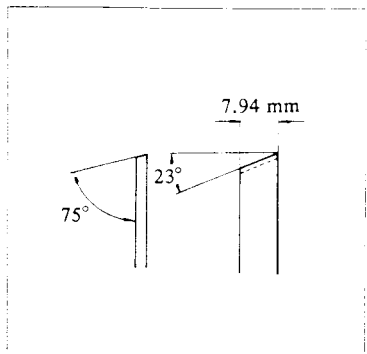

7. Stitch length adjustment

The stitch length is regulated by pushbutton adjustment of a variable eccentric.

Open face plate cover ❶, and turn the pulley in the normal operating direction while pressing pushbutton ❷ so the pushbutton will go in further. With the pushbutton kept in, turn the pulley forward and back until your desired stitch length is in line with the mark on the scale of the face plate, and then release the pushbutton.

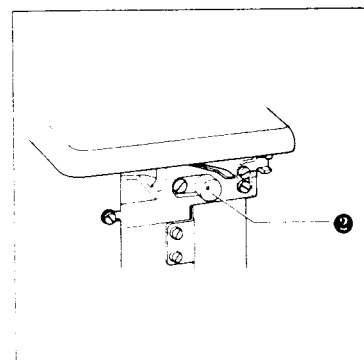
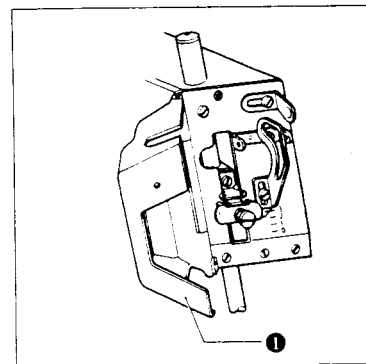

The numerals on the scale indicate stitch length in millimeters, but actual stitch length varies with the kind and thickness of the work and the differential feed.

8. Differential feed adjustment

The differential feed can be adjusted to any of three kinds: Stretch, normal, and gather.

Loosen differential adjusting lever set screw ❶, and raise or lower differential adjusting lever ❷ as necessary.

The lever must be lowered below the 1.0 mark for gather feed.

Set the lever at the 1.0 mark for normal feed.

The lever must be raised above the 1.0 mark for stretch feed.

After the adjustment, tighten the differential adjusting lever set screw securely by hand.

* There are three kinds of differential feed scales ❸:

One for denim, another for ruffler, and the last for bulky materials.

* When the differential adjuster assembly is attached to your machine, the differential ratio can be changed with your knee while operating the machine.

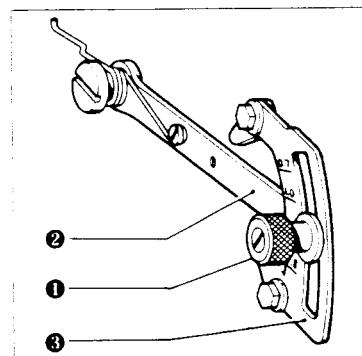

D. STANDARD ADJUSTMENTS

1. Left hand looper and needle bar adjustment

* When adjusting the two-needle model, adjust in reference to the left needle.
 In case of the single-needle model, right needle (dotted line) not adjusted.

- (1) In case of sewing machines made to the standard specifications, adjust the distance between the needle point and the top of the throat plate to 11 mm when the needle is up highest.
 The sewing machine of the high-lift specifications must be adjusted to a distance of 11.5 mm between them.
- * In case two-needle is used, make an adjustment by turning the needle bar so that right needle ① will be 0.2 ~ 0.3 mm forward of left needle ②.

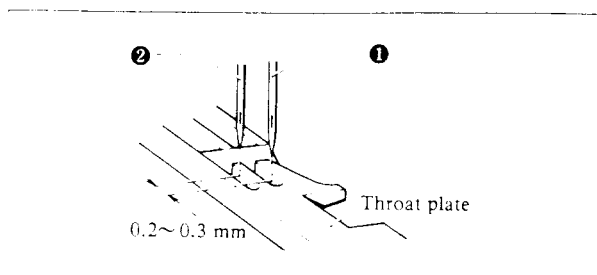
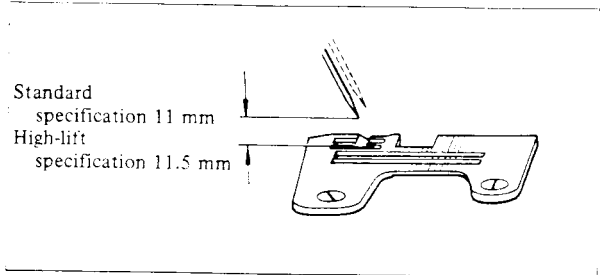

- (2) Tilt the left hand looper by 1 ~ 1.5 mm, insert it all the way into the left hand looper holder, and install it.

- (3) In case of sewing machines made to the standard specification, adjust the distance between the left hand looper point and the needle center to 4.5 mm when the left hand looper is at the leftmost position. The sewing machine of the high-lift specifications must be adjusted to a distance of 2.7 mm between them.

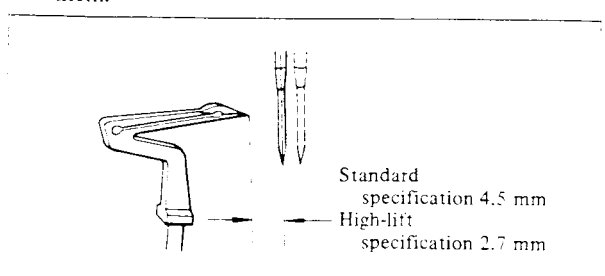
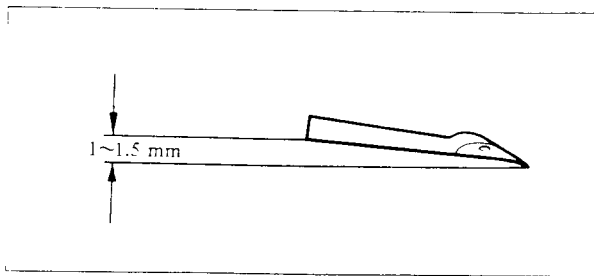

- (4) With the point of the left hand looper in line with the center of the needle, make an adjustment so that the point of the left hand looper will push the needle 0.05 ~ 0.1 mm (i.e., slightly contact the needle) in the upward travel of the needle.

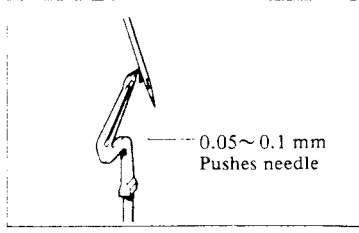

In case of two-needle is used, make an adjustment so that the point of the left hand looper will touch both needles uniformly, or touch the right one slightly more than the left one.

- (5) Under the condition of (4), push the needle with movable needle guard ③ until there is a clearance of 0 ~ 0.05 mm between the needle and the point of the left hand looper.
 Also, adjust the clearance between the needle and needle guard front ④ to 0.3 ~ 0.5 mm.

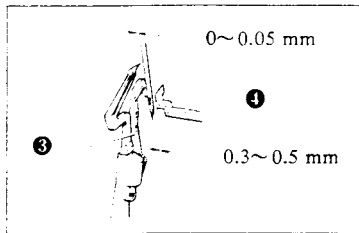

2. Right hand looper adjustment

(1) Make an adjustment so that, when right hand looper ① meets left hand looper ②, the point of the right hand looper will pass clear of the left hand looper about 0.1 mm below its projected part.

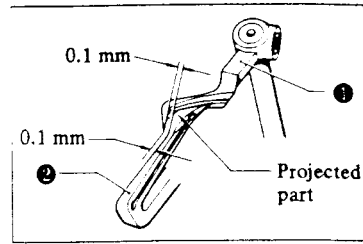

(2) Select meeting measurements from the table below.

There are three types of right hand loopers: Standard type, high-lift type, and the last for mock safety.

Spec.	Single-needle		Two-needle (Four-thread overedge)		Two-needle (Mock safety)	
	Standard	High-lift	Standard	High-lift	Standard	High-lift
A	7.2	8.2	7.2	8.2	7.2	8.2
B	5.6	5	5.6	5	5.6	5

(In millimeters)

* Check part A on the right hand looper arm and see whether the machine is for standard use (S) or high-lift use (H).

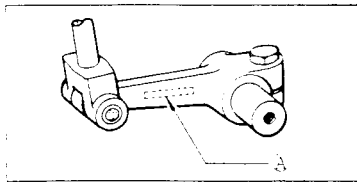

(148378—Standard specification)
(148381—High-lift specification)

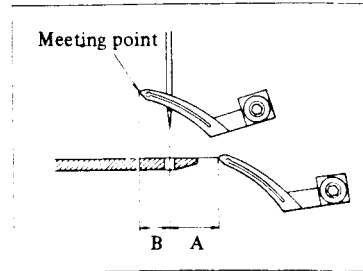

(3) Meeting measurements for spreader ③ are the same as shown at above.

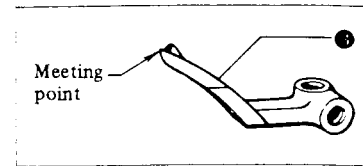

3. Knives adjustment

- (1) Adjust the height of stationary knife until the point of the stationary knife is flush with the top of the throat plate.
- (2) Adjust the height of movable knife ① so that, when the movable knife is lowered to its lowest position, it will engage stationary knife ② 0.5 ~ 1 mm deep.

Also align the stationary knife corner with the end face of the movable knife.

[Caution]

The above-mentioned adjustment is not necessary because your machine has already been adjusted on the assembly line.

If a readjustment should become necessary, exercise great care not to damage the knives due to excessive engagement of the movable and stationary knives.

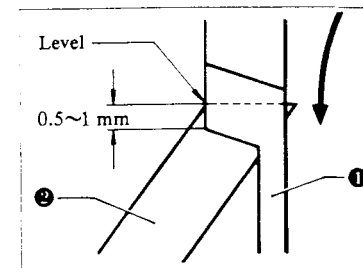
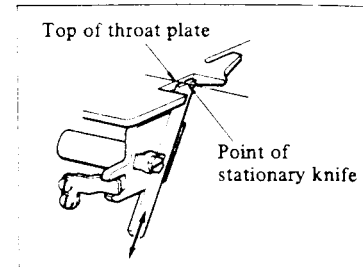

4. Feed dogs adjustment

Loosen screw ②, and raise or lower differential feed dog (front) ① to the correct height.

Loosen screw ④ and adjust main feed dog (back) ③.

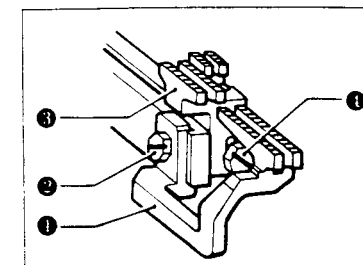

- (1) Turn the pulley until the feed dogs are raised to the highest position, and adjust them to the following height above the top of the throat plate.

- 1.0 mm for light materials
- 1.3 mm for medium-heavy materials
- 1.5 mm for heavy materials

Install chaining-off feed dog ⑤ at the same height as feed dog (back).
If chaining-off stitches hardly come out, lower it as shown at right.

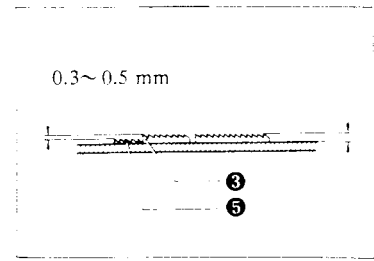



5. Differential feed ratio adjustment

The differential range of your sewing machine is shown in the table of "SPECIFICATIONS" on pages 2 ~ 4.
It can be changed as mentioned below.

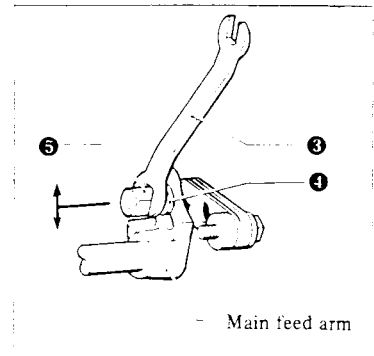
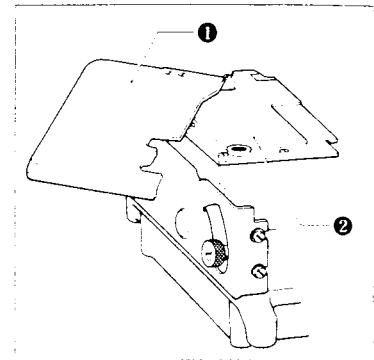
- (a) Remove cloth plate ① and feed table cover ②.
- (b) Loosen nut ⑤ on main feed shaft ④, using accessory wrench ③.
- (c) Position the main feed shaft by referring to the table below, and tighten the nut securely.

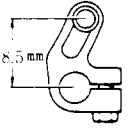
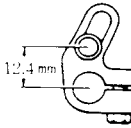
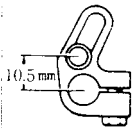
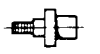

The table below shows the position of the main feed shaft vs. differential feed ratio.

Specifications	Run stitching	Ruffler	Bulky
Differential feed ratio	0.6~1.8	1~3	1.3~4
Main feed shaft position			
Main feed shaft			 (eccentric shaft)

* The eccentric shaft is installed only in machines made to "bulky specifications."

E. INSTALLATION AND ADJUSTMENT OF ATTACHMENTS

1. Blind hemming guide

(1) Replace the presser foot assembly with presser foot assembly for blind hemming ①.

(2) Install blind hemming guide assembly ② in such a way that its corner A contacts the corner of throat plate support bracket ③.

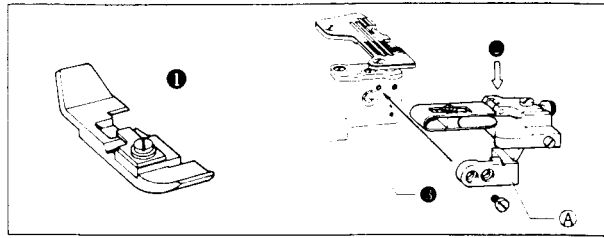

(3) Adjust the clearance between presser foot ④ and blind hemming guide ⑤ by moving the presser foot to the right or left so that the work will freely pass between them.

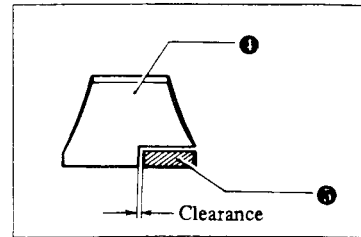

(4) Adjust the clearance between the tip of blind hemming guide assembly A ⑥ and the blind hemming guide by moving the blind hemming guide assembly A to the right or left so that the work will freely pass between them.

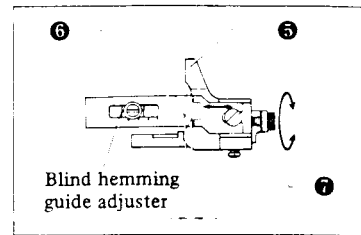

* Adjust blind hemming width by moving the blind hemming guide adjuster to the right or left.

(5) Adjust the position of the blind hemming guide by turning blind hemming guide adjusting screw ⑦ after actual sewing.

Case (a): Turn the blind hemming guide adjusting screw clockwise to move the blind hemming guide to the right until it is positioned as shown in Case (c).

Case (b): Turn the blind hemming guide adjusting screw counterclockwise to move the blind hemming guide to the left until it is positioned as shown in Case (c).

* Generally, attention must be paid to the following to prevent irregular stitching.

1. Make sure that the work has constant tension.
2. Reduce the differential feed ratio when gathering.

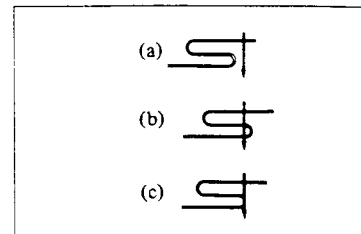

2. Serging

(1) Replace the presser foot assembly with presser foot assembly for serging ①.

(2) Install serging guide assembly ② on front cover support assembly ③.

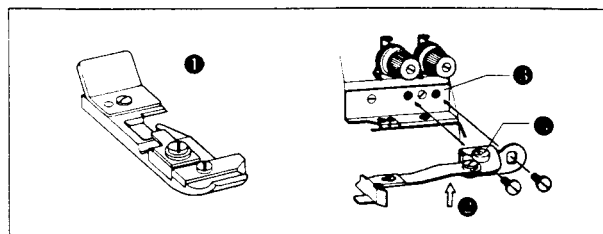

- (3) Turn stopper ⑤ until part ⑥ of the serging guide is parallel with differential feed dog ④.
- (4) Actually sew the work, and adjust the bight by moving the serging guide to the right or left.

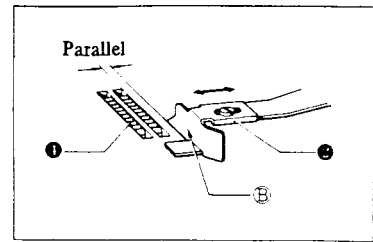

3. Turn-down hemming

- (1) Replace the presser foot assembly with presser foot assembly for turn-down hemming ①.
- (2) Replace the throat plate with that for turn-down hemming.
(Throat plates for 2 mm and 4 mm bights) are available.
- (3) Adjust the position of the chain off finger in the following order.
 - (a) Loosen set screw ②.
 - (b) Make a clearance between the throat plate chain off plate ③ or ④ and chain off finger ⑤ just enough for the work to pass.

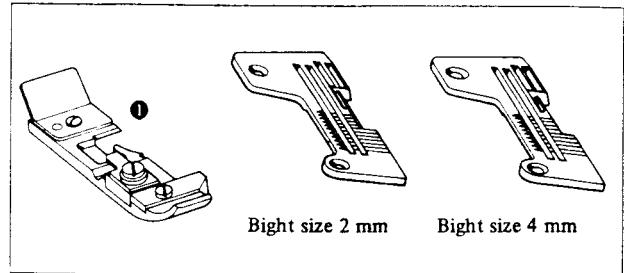

In case of 2 mm bight, push the chain off finger to the left.
In case of 4 mm bight, push the chain off finger to the right.

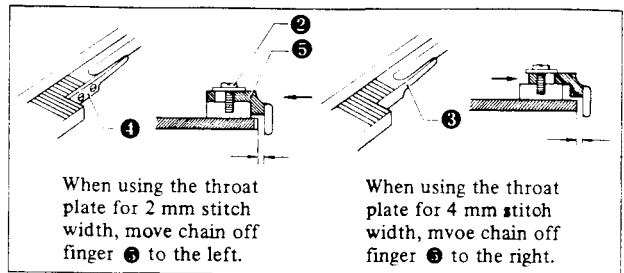

- (4) Cutting width should be about twice the bight.
 - * When sewing woven fabrics, use a little wider cutting width in crosswise directions than in lengthwise directions.
- (5) Use a thread tension similar to that used for blind hemming so that sewn stitches will look like single-thread hemming stitches as shown in right.

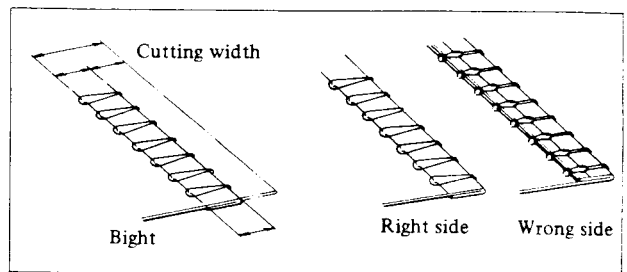

4. Taping

- (1) Replace the presser foot assembly with presser foot for taping ①.
- (2) Install tape guide ② on face plate cover ③.

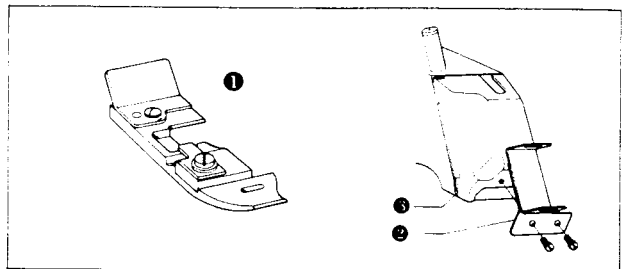

- (3) Actually sew the work, and move the presser foot assembly to the right or left to adjust the position where tape ④ will be sewn.

[Caution]

Select a bight so the right edge of tape will not be cut by the knives. Otherwise, tape may not be sewn on in a satisfactory way.

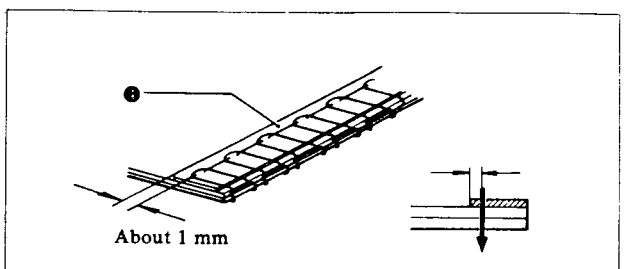

TROUBLESHOOTING GUIDE

Trouble	Cause	Remedy	Page
Thread break	Wrong threading	See paragraph on threading.	9
	Excessive tension disc pressure.	Adjust to proper pressure.	11
	Poor-quality thread.	Use thread of good quality.	8
	Thread is too thick for needle eye.	Use needle of correct size or thread of correct count.	8
	Needle setting incorrectly.	See paragraph on needle installing.	8
	Needle groove and needle eye finished poorly.	Replace with good needle.	8
	Needle, loopers and thread take-ups not positioned properly to one another.	See paragraphs on adjustment of left hand looper vs. needle bar and thread tension.	14 10
Stitches skip	Needle, loopers, throat plate, thread passage have flaws.	Smooth with oil stone or buff.	/
	Wrong threading.	See paragraph on threading.	9
	Excessive tension disc pressure.	Adjust to proper pressure.	11
	Needle setting incorrectly.	See paragraph on setting needle.	8
	Needle point blunt or bent.	Replace with new needle.	8
	Needle, loopers and thread take-ups not positioned properly to one another, or have incorrect clearance.	See paragraphs on adjustment of left hand looper vs. needle bar and thread tension.	14 10
	Needle and needle guard not positioned properly to one another.	See paragraph on adjustment of left hand looper vs. needle bar.	14
	Looper point hangs down.	Correct with oil stone, or replace with new looper.	/

Trouble	Cause	Remedy	Page
Needle break	Needle installed incorrectly.	See paragraph on setting needle.	8
	Needle bent.	Replace with new needle.	8
	Needle and loopers positioned improperly to one another.	See paragraphs on adjustment of left hand looper vs. needle bar and adjustment of right hand looper.	14 15
	Needle and needle guard positioned improperly to one another.	See paragraph on adjustment of left hand looper vs. needle bar.	14
Doesn't work well without cloth.	Wrong threading.	See paragraph on threading.	9
	Excessive thread tension.	Adjust to correct thread tension.	11
	Loopers, thread take-ups, and thread guide not positioned properly to one another.	See paragraph on thread tension.	10
	Main and differential feed dogs not uniform in height.	See paragraph on feed dog adjustment.	15
	Throat plate's chain off finger has flaws.	Smooth with sandpaper and polish with buff.	
Improper thread nipping.	Wrong threading.	See paragraph on threading.	9
	Thread is too thick for needle hole.	Replace with correct needle or thread.	8
	Tension discs don't work right.	Remove dust from between tension discs to let them work smoothly.	
	Needle loopers and thread take-ups positioned improperly to one another.	See paragraphs on adjustment of left hand looper vs. needle bar and thread tension.	14 10
Poor trimming performance	Stationary knife worn.	Sharpen stationary knife; see paragraph on bight adjustment.	12
	Movable and stationary knives installed incorrectly.	See paragraph on knives adjustment.	15

Trouble	Cause	Remedy	
Needle makes too large holes in cloth.	Needle point blunt.	Replace with new needle.	8
	Needle too big for cloth.	Replace with smaller needle.	8
	Wrong threading.	See paragraph on threading	9
Irregular stitches	Thread not uniform in thickness.	Use thread of good quality.	8
	Thread passage defective.	Smooth thread passage.	
	Thread take-ups and thread guides not positioned properly to one another.	See paragraph on thread tension.	10
	Movable and stationary knives don't cut well.	See paragraph on bight adjustment (Caution 2).	12
	Stationary knife installed incorrectly.	See paragraph on knives adjustment.	15
Excessive wrinkles by sewing.	Needle too big.	Select needle suitable to cloth and threads.	8
	Differential feed not adjusted right.	See paragraph on differential feed adjustment.	13
	Presser foot pressure incorrect.	Adjust pressure correctly.	10
	Excessive thread tension.	Adjust to correct pressure.	11
	Movable and stationary knives don't cut well.	See paragraph on bight adjustment (Caution 2).	12
	Trimming width and throat plate's chain off finger size not balanced.	Adjust trimming width to throat plate, or replace throat plate.	12
	Feed dogs installed incorrectly.	See paragraphs on presser foot pressure adjustment and feed adjustment.	10 15

SINGER

* A TRADE MARK OF THE SINGER COMPANY

831U · 832U
192510-3-02